

Current Transducer HAL 50..600-S

For the electronic measurement of currents: DC, AC, pulsed..., with galvanic isolation between the primary circuit (high power) and the secondary circuit (electronic circuit).

$I_{PN} = 50 \dots 600 \text{ A}$

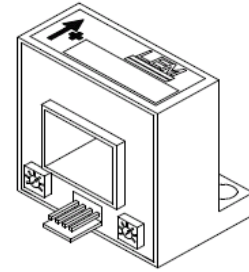

Electrical data

Primary nominal current rms I_{PN} (A)	Primary current measuring range ⁴⁾ I_{PM} (A)	Type	RoHS since date code
50	± 150	HAL 50-S	46180
100	± 300	HAL 100-S	46065
200	± 600	HAL 200-S	46090
300	± 900	HAL 300-S	46142
400	± 1000	HAL 400-S	46114
500	± 1000	HAL 500-S	46306
600	± 1000	HAL 600-S	46059

I_p	Overload Capability (Ampere Turns)	30,000	A
V_{OUT}	Output voltage (Analog) @ ± I_{PN}	± 4	V
R_L	Load resistance @ $T_A = 0 \dots +70^\circ\text{C}$	> 1	kΩ
	@ $T_A = -25 \dots +85^\circ\text{C}$	> 3	kΩ
V_C	Supply voltage (± 5 %)	± 15	V
I_C	Current consumption	< ± 25	mA
V_b	Rated isolation voltage rms ¹⁾	500	V
V_d	Rms voltage for AC isolation test, 50 Hz, 1 min	3	kV
R_{is}	Isolation resistance @ 500 V_{DC}	> 500	MΩ

Accuracy - Dynamic performance data

X	Accuracy @ I_{PN} , $T_A = 25^\circ\text{C}$, ± 15 V	< ± 1	%
ϵ_L	Linearity error ²⁾	< ± 0.5	% of I_{PN}
V_{OE}	Electrical offset voltage @ $T_A = 25^\circ\text{C}$	HAL 50-S < ± 20 HAL 100..600-S < ± 10	mV
V_{OM}	Magnetic offset voltage @ $I_p = 0$, after an overload of 3 x I_{PN}	HAL 50-S < ± 30 HAL 100..200-S < ± 20 HAL 300..600-S < ± 10	mV
TCV_{OE}	Temperature coefficient of V_{OE}	HAL 50-S < ± 2.0 HAL 100..600-S < ± 1.0	mV/K
TCV_{OUT}	Temperature coefficient of V_{OUT} (% of reading)	± 0.05	%/K
t_r	Response time to 90% of I_{PN} step	≤ 3	μs
BW	Frequency bandwidth (- 3 dB) ³⁾	DC .. 50	kHz

General data

T_A	Ambient operating temperature	- 25 .. + 85	°C
T_S	Ambient storage temperature	- 25 .. + 85	°C
m	Mass	app. 75	g
	Standard ⁴⁾	Safety EN 50178 : 1994 EMC EN50082-2: 1992 EN50081-1: 1992	
	Deviation in output when tested to EN 61000-4-6	< 20	% of I_{PN}
	Deviation in output when tested to EN 61000-4-3	< 20	% of I_{PN}

Notes : ¹⁾ Overvoltage Category III, Pollution Degree 2

²⁾ Excludes the electrical offset

³⁾ Derating is needed to avoid excessive core heating at high frequency.

⁴⁾ Please consult characterisation report for more technical details and application advice.

Features

- Hall effect measuring principle
- Galvanic isolation between primary and secondary circuit
- Isolation voltage 3000V
- Low power consumption
- Extended measuring range (3 x I_{PN})
- Isolated plastic case recognized according to UL 94-V0

Advantages

- Easy installation
- Small size and space saving
- Only one design for wide current ratings range
- High immunity to external interference

Applications

- AC variable speed drives
- DC motor drives
- Battery supplied applications
- Uninterruptable Power Supplies (UPS)
- Switched Mode Power Supplies (SMPS)
- Power supplies for welding applications.

Application domain

- Industrial

Dimensions HAL 50..600-S (in mm. 1 mm = 0.0394 inch)

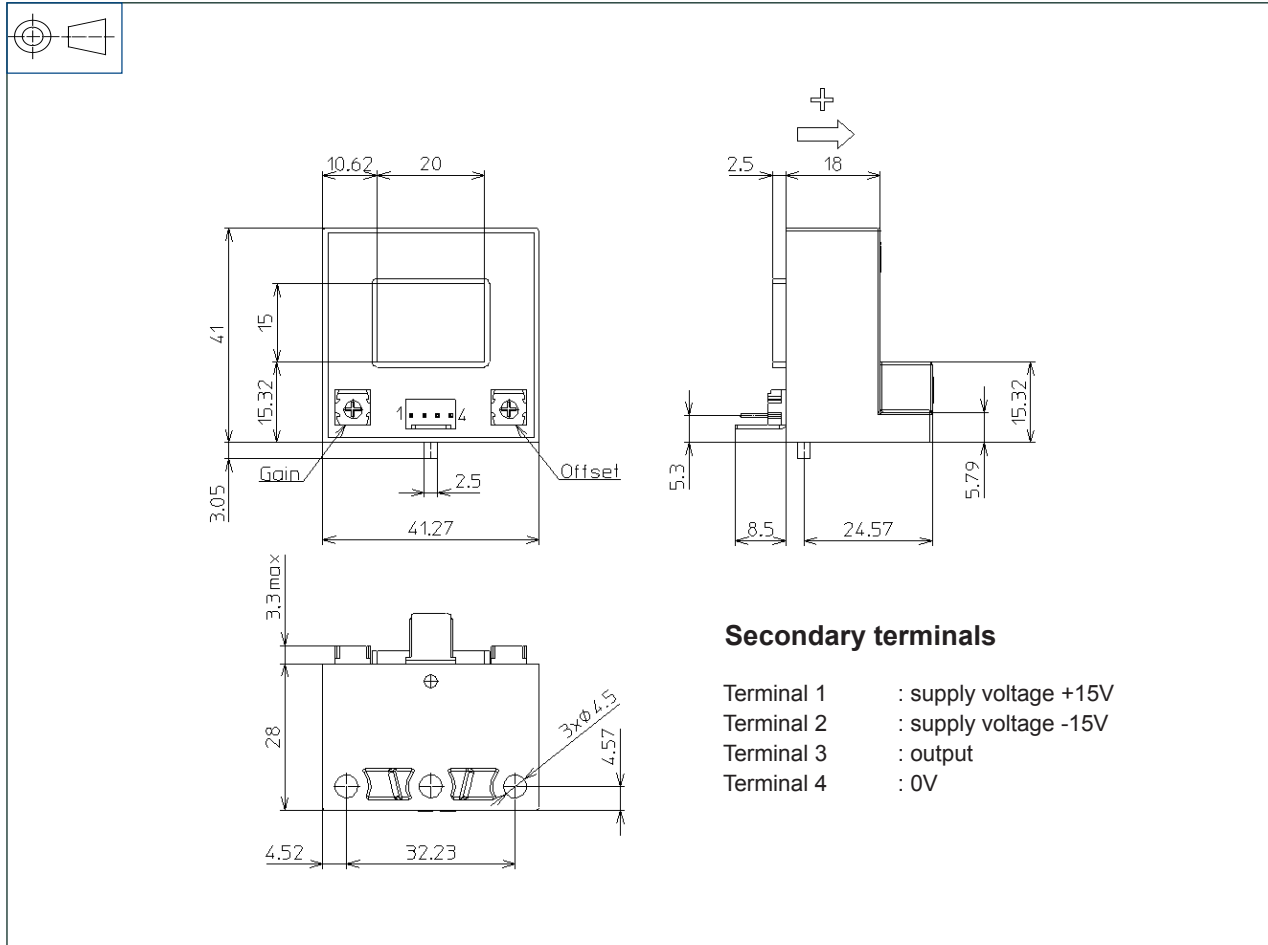

Mechanical characteristics

- General tolerance : ± 0.5 mm
- Primary through-hole : 20 mm x 15 mm
- Connection of secondary : Molex 5045-04-A

Remarks

- V_{OUT} is positive when I_p flows in the direction of the arrow.
- Temperature of the primary conductor should not exceed 90°C.
- This is a standard model. For different versions please contact us.

Safety



This transducer must be used in electric/electronic equipment with respect to applicable standards and safety requirements in accordance with the manufacturer's operating instructions.



Caution, risk of electrical shock

When operating the transducer, certain parts of the module can carry hazardous voltage (eg. primary busbar, power supply). Ignoring this warning can lead to injury and/or cause serious damage.

This transducer is a built-in device, whose conducting parts must be inaccessible after installation.

A protective housing or additional shield could be used.

Main supply must be able to be disconnected.