

Description

The Si4830 is the first wheel-tuned digital CMOS AM/FM radio receiver IC that integrates the complete receiver function from antenna input to audio output. Leveraging Silicon Laboratories' proven and patented digital low intermediate frequency (low-IF) receiver architecture, the Si4830 delivers superior RF performance and interference rejection in both AM and FM bands. Additionally, the digital core provides advanced audio conditioning for all environments, removing pops, clicks, and loud static in variable signal conditions. The superior control algorithm integrated in Si4830 provides easy and reliable control interface while eliminating all the manual tuned external components used in traditional solutions.

Like other successful audio products from Silicon Labs, Si4830 offers unmatched integration and PCB space savings with minimum external components and less than 20 mm² of board area, excluding the antenna inputs. The high integration and complete system production test simplifies design-in, increases system quality, and improves manufacturability. The receiver has very low power consumption, runs off two AAA batteries, and delivers the performance benefits of digital tuning to the legacy analog radio market.

Features

- Worldwide FM band support (64–108 MHz)
- Worldwide AM band support (520–1710 kHz)
- Selectable support for all AM/FM regional bands
- Wheel-tuned / Mechanical-tuned frequency support
- Mechanical volume control + off/on
- Excellent real-world performance
- Digital radio with leading low-IF architecture
- Automatic frequency control (AFC)
- Stereo/mono + tuning and stereo indicator
- EN55020 compliant
- Minimal BOM components w/ no manual alignment
- No external MCU required
- Two AAA batteries with 2.0 to 3.6 V supply voltage (T = 25° C)
- Wide range of ferrite loop sticks and air loop antennas
- 24-pin SSOP package
- RoHS compliant

Applications

- Table and portable radios
- Stereos
- Mini/micro systems
- Boomboxes
- Clock radios
- Modules
- Entertainment systems
- Toys, lamps, and any application needing an AM/FM radio

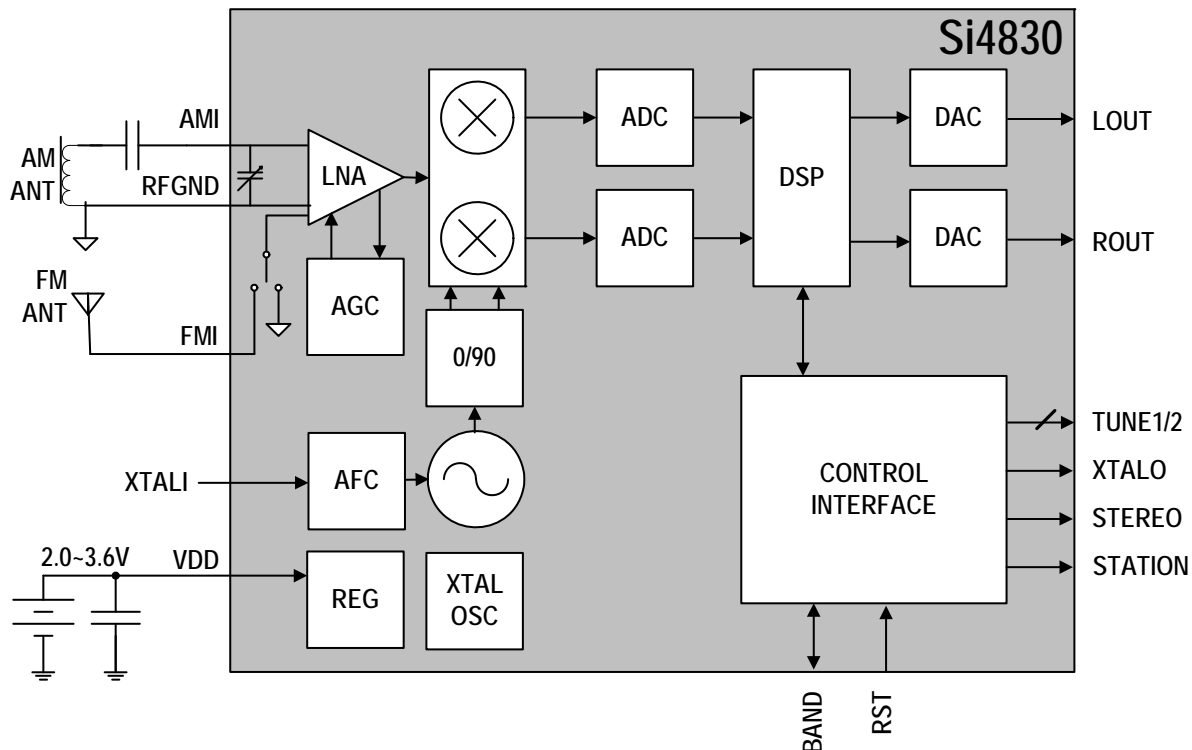

Selected FM Electrical Specifications

Parameter	Symbol	Conditions	Min	Typ	Max	Units
Input Frequency	f_{RF}		64	—	108	MHz
Sensitivity		(S+N)/N = 26 dB	—	2.2	—	μ V EMF
Input IP3			—	105	—	dB μ V EMF
Adjacent Channel Selectivity		\pm 200 kHz	—	50	—	dB
Alternate Channel Selectivity		\pm 400 kHz	—	65	—	dB
Audio Output Voltage			—	80	—	mV _{RMS}
Audio S/N			—	53	—	dB
Audio THD			—	0.1	0.5	%

Selected AM Electrical Specifications

Parameter	Symbol	Conditions	Min	Typ	Max	Units
Input Frequency	f_{RF}		520	—	1710	kHz
Sensitivity		(S+N)/N = 26 dB	—	25	—	μ V EMF
Audio S/N			—	56	—	dB
Audio Output Voltage			—	60	—	mV _{RMS}
Audio THD			—	0.1	—	%
Antenna Inductance			180	—	450	μ H

Package Information

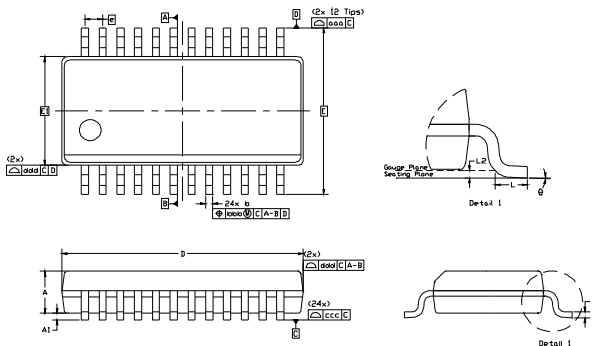

Table 1. Package Dimensions

Dimension	Min	Nom	Max	Dimension	Min	Nom	Max
A	—	—	1.75	L	0.40	—	1.27
A1	0.10	—	0.25	L2	0.25 BSC		
b	0.20	—	0.30	θ	0°	—	8°
c	0.10	—	0.25	aaa	0.20		
D	8.65 BSC			bbb	0.18		
E	6.00 BSC			ccc	0.10		
E1	3.90 BSC			ddd	0.10		
e	0.635 BSC						

Notes:

- All dimensions shown are in millimeters (mm) unless otherwise noted.
- Dimensioning and Tolerancing per ANSI Y14.5M-1994.
- This drawing conforms to the JEDEC Solid State Outline MO-137, Variation AE.
- Recommended card reflow profile is per the JEDEC/IPC J-STD-020 specification for Small Body Components.

Pin Assignments

Stereo	1	24	LOUT
BAND	2	23	ROUT
XTALO	3	22	DBYP
TUNE2	4	21	VDD2
TUNE1	5	20	VDD1
NC	6	19	XTALI
NC	7	18	Station
FMI	8	17	RSV2
RFGND	9	16	RSV1
NC	10	15	RST
NC	11	14	GND
AMI	12	13	GND