

## Datasheet

# Jupiter J-F2

Ultra Low Power  
Ultra Miniature 48-channel  
GPS receiver module

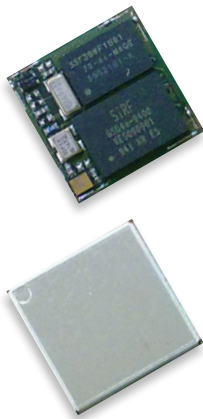

Top image shown  
without shield for demo  
purposes only

April 4, 2011

## CONTENTS

<b>1.0 Introduction</b> .....	1	5.1.7 Flash upgradability .....	10
<b>2.0 Technical description</b> .....	1	5.1.8 Reset input .....	10
2.1 Product applications .....	1	5.2 Data input output specifications .....	10
2.1.1 Compatibility .....	2	5.2.1 Voltages and currents .....	11
2.2 Receiver architecture .....	2	5.2.2 I/O surface mount pads .....	12
2.3 Major components .....	3	<b>6.0 Software interface</b> .....	13
2.4 Physical characteristics .....	3	6.1 NMEA output messages .....	13
2.5 Mechanical specification .....	3	6.2 SiRF OSP output messages .....	13
2.6 External antenna surface mount pads .....	4	6.3 Software functions and capabilities .....	14
2.7 I/O and power connections .....	4	<b>7.0 Mechanical drawing</b> .....	15
2.8 Environmental .....	4	<b>8.0 Evaluation kit</b> .....	17
2.9 Compliances .....	4	<b>9.0 Product handling</b> .....	17
2.10 Marking/Serialization .....	4	9.1 Product packaging and delivery .....	18
2.11 Active antenna gain requirements .....	5	9.2 Moisture sensitivity .....	18
<b>3.0 Performance characteristics</b> .....	5	9.3 ESD sensitivity .....	18
3.1 TTFF (Time To First Fix) .....	5	9.4 Safety .....	18
3.1.1 Hot start .....	5	9.5 Disposal .....	18
3.1.2 Warm start .....	5	<b>10.0 Ordering information</b> .....	18
3.1.3 Cold start .....	5	<b>11.0 Glossary and acronyms</b> .....	18
3.2 Time Mark Pulse (1PPS) .....	5		
3.3 Power management .....	6	<b>Figures</b>	
3.4 Differential aiding .....	7	Figure 1 Architecture .....	2
3.4.1 Differential GPS (DGPS) .....	7	Figure 2 Mechanical layout .....	15
3.4.2 Satellite Based Augmentation Systems (SBAS) .....	7	Figure 3 Pinout .....	16
3.5 Performance data .....	7	Figure 4 3D Model .....	17
3.6 Dynamic constraints .....	8		
<b>4.0 Multi-mode aiding</b> .....	8	<b>Tables</b>	
<b>5.0 Electrical requirements</b> .....	9	Table 1 Active antenna gain requirements .....	5
5.1 Power supply .....	9	Table 2 Performance Data .....	7
5.1.1 VDD 18 .....	9	Table 3 Power Requirements .....	11
5.1.2 External antenna voltage .....	9	Table 4 Digital Core and I/O voltage (Volatile) .....	11
5.1.3 RF (Radio Frequency) input .....	9	Table 5 DC Electrical Characteristics .....	11
5.1.4 Antenna gain .....	9	Table 6 LGA pad functions .....	12
5.1.5 Burnout protection .....	9	Table 7 Software features .....	14
5.1.6 Jamming performance .....	9		

## 1.0 Introduction

---

Building upon the SiRFstarIV™ architecture's high-performance and micro-power capabilities, the J-F2 device incorporates innovations such as SiRFaware™, SiRFInstantFix™ and Active Jammer Removal. The J-F2 can navigate to -160dBm and track to -163dBm, providing higher coverage, accuracy and availability. This next generation Jupiter Module consume only 23mW (1.8V) in 1-Hz TricklePower™ mode and can maintain hot-start conditions continuously in SiRFaware mode while drawing as little as 50-500uA. The J-F2 offers A-GPS support and operate with a 1.8V power supply. J-F2 supports a full range of satellite-based augmentation systems, including WAAS, EGNOS, MSAS and GAGAN. The GPS module combines the SiRFstarIV™ GSD4e™ GPS engine, TCXO, LDO, SAW filter, RTC and Flash memory (optional EEPROM for ROM device).

## 2.0 Technical description

---

**High-speed Location Engine** – Twice the available DSP memory and search speed of SiRFstarIII architecture for enhanced sensitivity and navigation performance, greater coverage, reduced time to fix and improved positional accuracy.

**Adaptive Micro power Manager** – Advanced power management with integrated LDO regulation to maintain hot-start conditions with minimal energy. Always ON 1.8V supply must be used.

**Smart Sensor Interface** – Intelligent sensor support to improve the location experience, enable greater context awareness, and open the door to superior indoor positioning accuracy. This is achieved via the DR I2C port and a 3 axis accelerometer.

**Active Jammer Remover** – Advanced DSP technology actively identifies and removes jammers prior to correlation. This feature maximizes GPS performance and helps identify issues during the design phase. Up to 8 jammers can be identified and removed.

### High Performance Solution:

- High sensitivity navigation engine (PVT) tracks as low as -163dBm
- 48 track verification channels
- SBAS (WAAS), EGNOS, MSAS, GAGAN.

### Adaptive Micro power Controller:

- Only 50 to 500uA maintains hot start capability

### Active Jammer Remover:

- Removes in-band jammers up to 80 dB-Hz
- Tracks up to 8 CW jammers

### Advanced Navigation Features:

- Smart sensor I<sup>2</sup>C interface
- Interrupt input for context change detection

## 2.1 Product applications

The J-F2 is designed specifically for applications where rapid TTFF and operation under low signal levels along with a small form factor are primary requirements. This module offer high performance and maximum flexibility in a wide range of OEM configurations.

The high sensitivity of this module makes it ideal for:

**Navigation systems** – where athermic glass, or an unsuitably positioned antenna inside the vehicle will reduce visibility and signal strength vehicle and people tracking devices – where satellites are obstructed by partially covered car parks and walkways, tracking even continues indoors.

**Marine buoys** – where multipath and unstable sea conditions make satellite visibility almost impossible.

**Irregular asset tracking** – where construction machinery is located in covered yards and areas of dense foliage.

**People tracking** – home detention and house arrest applications, emergency location services.

**Mobile platforms** where size and power consumption are critical along with maximum flexibility of integration and performance.

**Security applications** where an ultra compact design and high performance is required along with maximum integration flexibility.

**Toll Collection** systems for vehicles.

**People Tracking** applications for health, Security, safety.

## 2.1.1 Compatibility

The J-F2 incorporates a new technology far advanced compared to the previous SiRFstarIII designs. Offering an upgrade path from existing Navman and competitive designs.

J-F2 incorporates the same footprint as the Jupiter3 (J3) with the same pad dimensions. Pinouts are adapted to make use of the SiRFstarIV advanced technology. Please check the required integration requirements for more details.

Note that the J-F2 is not backwards compatible with the J3.

NMEA version 3.0 protocol is supported as well as the new SiRF ONE SOCKET binary PROTOCOL (OSP).

## 2.2 Receiver architecture

The functional architecture of the J-F2 receivers is shown in Figure 1.

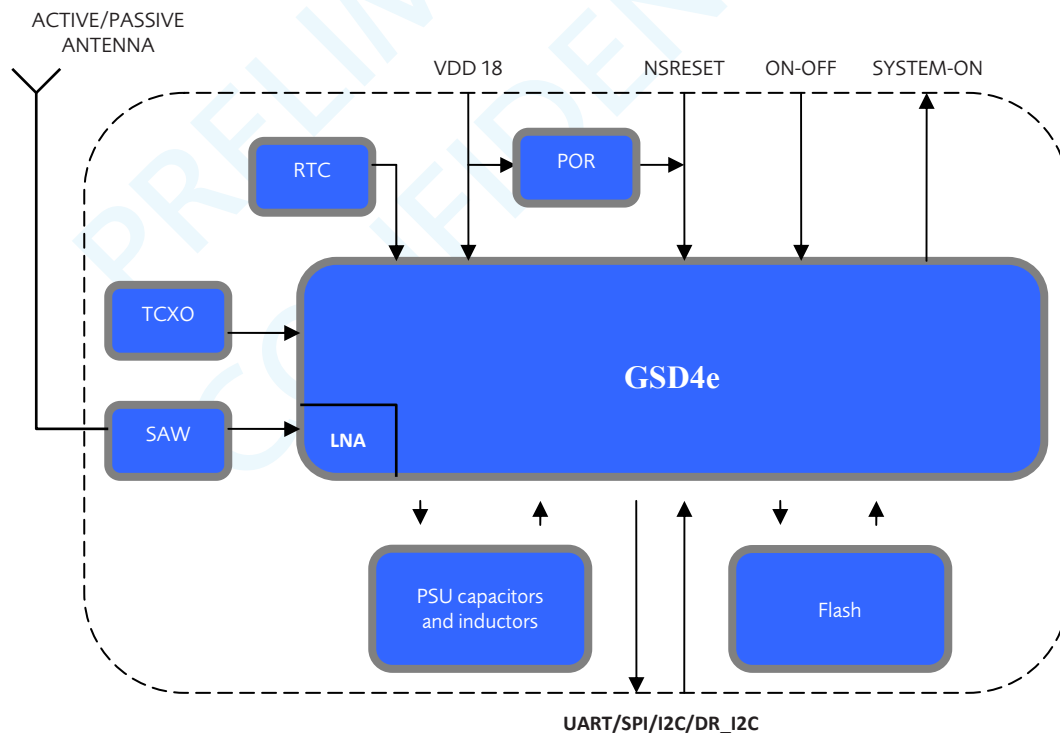

Figure 1. Architecture

**Note:** LNA is included in the GPS chip for passive antenna operation.

## 2.3 Major components

All power supply components are on board including capacitors and additional Power-On-Reset (POR) for the 1.8V supply.

A 1.8V always ON supply with noise and ripple characteristics mentioned in section 5.1 is critical for reliable operation. This can be a 1.8V supply that is backed up by a very low current 1.8V LDO that will supply the 14uA typical when the GPS has been shut down into Hibernate mode. Refer to the Designer's Notes for additional details. If the 1.8V supply is inadvertently cut off the GPS 1.8V POR will shut it down into Hibernate with loss of data. It is important that the GPS has sufficient bulk capacitance to enable the GPS to shut down gracefully into Hibernate mode. In addition this would only be possible if a 1.8V battery backed supply is also provided to retain the GPS in Hibernate mode ready to accept an ON pulse once the main 1.8V supply is available again.

**ON-OFF (1.8v - 3.6V).** This control signal is used to turn ON and turn OFF the GPS. Main 1.8V power must be already available and stable. There is a minimum time period before the receiver will accept an ON pulse once the 1.8V power has been first applied, 3 seconds is a good example. It is suggested the SYSTEM-ON line is monitored as it will indicate when the GPS can accept an ON pulse after the first 1.8V power application. If a 1.8V battery back-up system is used and the GPS has already been powered up, shut down should be done via the ON-OFF line. The SYSTEM-ON line will not indicate a READY state if the main 1.8V supply is re-applied. The battery back-up supply has kept the system ready and valid and an ON pulse can be applied as soon the main 1.8V supply is stable. Note, clean application of this 1.8V supply is required.

**SYSTEM-ON.** This is an active high (1.8V) indication that the system is ready to receive an ON pulse or that the system is ON and running. A short duration active high pulse occurs on this line if the main 1.8V supply has been connected (if no 1.8V battery back up is used) and is valid. Note, that noisy or unstable application of the 1.8V power will cause the 1.8V POR monitor to shut the GPS down and lose data.

**Band pass SAW filter (1.575 GHz):** This filters the GPS signal and removes unwanted signals caused by external influences that would corrupt the operation of the receiver. The filtered signal is fed to the RF input of GSD4e chipset for further processing. The filter has a bandwidth of 2 MHz.

**GSD4e chip:** This single chip GPS device includes an integrated Baseband, RF and LNA sections.

**LNA (Low Noise Amplifier):** This amplifies the GPS signal and provides enough gain for the receiver to use a passive antenna. A very low noise design is utilised to provide maximum sensitivity. This LNA is internal to the GPS baseband and can be switched between low and high gain mode.

**VDD 18:** The primary always ON supply voltage for the module. A very low noise 1.8V always ON source must be used.

**NSRESET:** This is the user Reset input, however it is recommended not be used. The module has two internal POR devices. One POR for the 1.2V core and a POR for the 1.8V supply. No user POR is required.

There are Boot jumpers to select I2C/UART/SPI communications on the single HOST port.

**1 x UART:** This is the primary serial communications port for NMEA or SiRF OSP protocols.

**1 x HOST SPI:** The main UART also functions as a SPI interface. Hardware selectable.

**1 X HOST I2C:** The main UART also functions as an I2C interface. Hardware selectable.

**DR\_I2C:** This port is used for MEMS sensors and serial EEPROM is also supported on this port.

**TCXO (Temperature Compensated Crystal Oscillator 0.5ppm):** This highly stable 16.369 MHz oscillator controls the down conversion process for the RF block.

**FLASH** – 16MB storage of operational software.

## 2.4 Physical characteristics

The J-F2 receiver has advanced miniature packaging and a LGA footprint and is smaller than the Jupiter 32 and similar in size to the Jupiter3 (J3). It is a surface mount device packaged on a miniature printed circuit board, with a metallic RF enclosure on one side. There are 32 surface mount connection pads with a base metal of copper and an Electroless Nickel Immersion Gold (ENIG) finish.

## 2.5 Mechanical specification

The physical dimensions of the J-F2 are as follows:

- length: 11.0 mm  $\pm$  0.1 mm
- width: 11.0 mm  $\pm$  0.1 mm
- thickness: 2.25 mm max
- weight: 1 g max

Refer to Figure 2 for the J-F2 mechanical layout drawing.

## 2.6 External antenna surface mount pads

The RF surface mount pad for the external antenna has a characteristic impedance of 50 ohms.

## 2.7 I/O and power connections

The I/O (Input / Output) and power connections use surface mount pads. Note that GPIO and UART/SPI/I2C/DR\_I2C are 1.8V signals.

## 2.8 Environmental

The environmental operating conditions of the J-F2 are as follows:

**Note:** Temperature measured on J-F2 shield.

- temperature:  $-40^{\circ}\text{C}$  to  $+85^{\circ}\text{C}$
- humidity: up to 95% non-condensing or a wet bulb temperature of  $+35^{\circ}\text{C}$
- altitude:  $-304$  m to 18 000 m
- vibration: random vibration IEC 68-2-64
- max. vehicle dynamics: 500 m/s
- shock (non-operating): 18 G peak, 5 ms

## 2.9 Compliances

The J-F2 complies with the following:

- Directive 2002/95/EC on the restriction of the use of certain hazardous substances in electrical and electronic equipment (RoHS)
- CISPR22 and FCC: Part 15, Class B for radiated emissions
- Manufactured in an ISO 9000: 2000 accredited facility
- Manufactured to TS 16949 requirement (upon request)

## 2.10 Marking/Serialization

The J-F2 supports a 2D barcode indicating the unit serial number below. The Navman 13-character serial number convention is:

- characters 1 and 2: year of manufacture (e.g. 10 = 2010, 11 = 2011)
- characters 3 and 4: week of manufacture (1 to 52, starting first week in January)
- character 5: manufacturer code
- characters 6 and 7: product and type
- character 8: product revision
- characters 9-13: sequential serial number

## 2.11 Active antenna gain requirements

LNA Gain Setting	Gain (dB)	Noise Figure (dB)	Recommended External Gain Range (dB)
Low	6.0–10.0	8.5–9.5	16–30
High (default)	16.0–20.0	1.2–2.0	8–18

**Table 1. Active antenna gain requirements**

**Notes:**

1. Recommended external gain range is total any external gain, such as antenna or external LNA and any passive loss due to cables, connectors, filters, matching network, etc.
2. In the High Gain setting an external LNA is not recommended.
3. In the Low Gain setting, the noise figure of the external LNA or active antenna must be chosen to ensure that the total cascaded noise figure is sufficiently low to meet overall system design requirements.

## 3.0 Performance characteristics

### 3.1 TTFF (Time To First Fix)

TTFF is the actual time required by a GPS receiver to achieve a valid position solution. This specification will vary with the operating state of the receiver, the length of time since the last position fix, the location of the last fix, and the specific receiver design.

Aiding is a method of effectively reducing the TTFF by making every start a Hot or Warm start.

**Note:** AGPS is supported as standard. NAVMAN provides a server based system that supports SGEE and an on board self aiding system that supports CGEE. Contact NAVMAN for details on this service and for application notes.

#### 3.1.1 Hot start

A hot start results from a software reset after a period of continuous navigation, or a return from a short idle period (i.e. a few minutes) that was preceded by a period of continuous navigation. In this state, all of the critical data (position, velocity, time, and satellite ephemeris) is valid to the specified accuracy and available in memory. Requires always ON 1.8V main supply.

#### 3.1.2 Warm start

A warm start typically results from user-supplied position and time initialisation data or continuous RTC operation with an accurate last known position available in memory. In this state, position and time data are present and valid but ephemeris data validity has expired. Requires always ON 1.8V main supply.

#### 3.1.3 Cold start

A cold start acquisition results when either position or time data is unknown. Almanac information is used to identify previously healthy satellites.

Please refer to section 3.5 for performance data.

### 3.2 Time Mark Pulse (1PPS)

A 1PPS time mark pulse is provided as an output with a width of 200ms. This signal has not been verified or characterized for all operational conditions.

**Note:** The GPS will only provide a 1PPS when a 3D fix has been obtained. When the fix degrades below a 3D solution, the 1PPS will be blanked. Once the fix quality improves back to a 3D FIX the 1PPS will again be output.



## 3.3 Power management

The following paragraphs describe the six power management modes supported by the J-F2. Note that power consumption will be lower if AGPS is used.

### Hibernate Mode

This is the lowest power consumption state (14uA typical) and allows a Hot start within 2-4 hours of last shut down. The GPS receiver must have had a valid fix with sufficient visible satellites before having been shut down via the ON-OFF line or serial command. Note, if AGPS is used there will be no time limit as long as the AGPS data is still valid.

### Advanced Power Management (APM)

**APM\_REQ** – Input message used to request a transition to Advanced Power Management mode

When sent in at full power mode, a direct transition is requested to the Advanced Power Management low power mode.

When sent from any other low power mode, first a default transition is performed to full power mode and then, immediately a transition from the full power mode to the Advanced Power Management low power mode is performed. In either case, a single Power Mode Response message will confirm this message.

Criteria to select with APM:

Num Fixes: number of fixes to collect

Time Between Fixes (s): time, in seconds, between the set of fixes and the next set.

Max Hrz. Error (m): maximum horizontal error to be used to get the position. The larger this error is, the quicker the fix, but the position may not be as precise. A value of 0 equates to No Maximum value.

Max Vrt. Error (m): maximum vertical error to be used to get the position. The larger this error is, the quicker the fix, but the position may not be as precise.

Priority: The priority to be used when computing a fix. The three values are – time, power, and user defined.

Max Off Time (ms): the time for the Rx to 'sleep'.

Max Search Time (ms): amount of time that the Rx will attempt to search for available signals before timing out.

### SiRFaware™

**MPM\_REQ** – Input message used to request a transition to Micro Power Management mode

When sent in at full power mode, a direct transition is requested to the Micro Power Management low power mode. When sent from any other low power mode, first a default transition is performed to full power mode and then, immediately a transition from the full power mode to the Micro Power Management low power mode is performed. In either case, a single Power Mode Response message will confirm this message.

### Adaptive Trickle Power (ATP)

**ATP\_REQ** – Input message used to request a transition to Trickle Power Management mode

When sent in at full power mode, a direct transition is requested to the Adaptive Trickle Power Management low power mode. When sent from any other low power mode, first a default transition is performed to full power mode and then, immediately a transition from the full power mode to the Adaptive Trickle Power Management low power mode is performed. In either case, a single Power Mode Response message will confirm this message.

Criteria to select when selecting ATP:

Duty Cycle (%): percentage of the time for the Rx to be updating. Also known as the Update Rate.

On Time (ms): the time per second that the Rx will operate.

Max Off Time (ms): maximum time that the Rx will be off.

Max Search Time (ms): amount of time that the Rx will attempt to search for available signals before timing out.



## Push to Fix mode (PTF)

**PTF\_REQ** – Input message used to request a transition to Push-To-Fix Power Management mode

When sent in at full power mode, a direct transition is requested to the Push-To-Fix Power Management low power mode. When sent from any other low power mode, first a default transition is performed to full power mode and then, immediately a transition from the full power mode to the Push-To-Fix Power Management low power mode is performed. In either case, a single Power Mode Response message will confirm this message.

Criteria to select for PTF – Push to Fix.

Push To Fix Period (s): amount of time that the Rx is to sleep.

Max Search Time (ms): amount of time that the Rx will attempt to search for available signals before timing out.

## Full Power Mode

**FP\_MODE\_REQ** – Input message used to request a transition to Full Power mode

When sent in at any of the low power modes, the current low power mode is cancelled and a direct transition is requested to the full power mode.

## 3.4 Differential aiding

### 3.4.1 Differential GPS (DGPS)

RTCM DGPS is not available on J-F2.

### 3.4.2 Satellite Based Augmentation Systems (SBAS)

The J-F2 is capable of receiving WAAS and EGNOS, MSAS, GAGAN differential corrections which are regional implementations of SBAS. SBAS improves horizontal position accuracy by correcting GPS signal errors caused by ionospheric disturbances, timing and satellite orbit errors.

## 3.5 Performance data

Parameter	Description	Performance			
		Min	Type	Max	Unit
Horizontal Position Accuracy <sup>(a)</sup>	Autonomous	–	<2.5	–	m
Velocity Accuracy <sup>(b)</sup>	Speed	–	<0.01	–	m/s
	Heading	–	<0.01	–	°
Time To First Fix <sup>(c)</sup>	Hot start: Autonomous	–	<1	–	s
	Warm start: Autonomous	–	<32	–	s
	Cold start: Autonomous	–	<35	–	s
Sensitivity	Autonomous Acquisition	–	–147	–	dBm
	Tracking	–	–163	–	dBm
	Navigation	–	–160	–	dBm

Table 2. Performance data

## 3.6 Dynamic constraints

The J-F2 receiver will lose track if any of the following limits are exceeded:

- velocity: 500 m/s max
- acceleration: 4 G (39.2 m/s<sup>2</sup>) max
- vehicle jerk: 5 m/s<sup>3</sup> max
- altitude: 18 000 m max (referenced to MSL)

## 4.0 Multi-mode aiding

---

### SiRFaware advanced technology features:

Opportunistic ephemeris decode and advanced power management, allowing the GPS receiver to stay in a hot-start condition nearly continuously while consuming very little power. Local ephemeris prediction, capturing ephemerides, and predicting them for up to three days in advance, boosting sensitivity and performance. Dynamic contextual awareness, monitoring temperature change and available sensors to detect movement and predict sky view availability to conserve power and boost performance.

### Software Managers

The Context Manager determines device context—stationary, walking, running, driving, etc.—to optimize navigation performance and power management.

The Energy Manager limits power consumption to the lowest necessary for the requested position accuracy.

The Uncertainty Manager limits time and ephemeris uncertainty to maintain hot start conditions, and also monitors other environmental changes to maintain very low power consumption.

The MEMS Manager coordinates and calibrates all available sensors, selecting the best sensor for a task.

The Protocol Manager abstracts the various A-GPS protocols (SUPL, Control Plane RRC and RRLP, ASN.1 encoding/decoding) from the application, and provides a seamless interface to support multimode A-GPS session management, including multiple simultaneous sessions.

Opportunistic ephemeris decode and advanced power management allow the GPS receiver to stay in a hot-start condition nearly continuously while consuming very little power.

CGEE captures ephemeris data from satellites locally and predicts ephemeris up to 3 days

SGEE does not require local ephemeris collection from satellites, it receives the extended ephemeris data from a server

**Note:** The module supports AGPS as standard. NAVMAN provides a server for customers to download the SGEE file. Contact NAVMAN for software design support for this service.

## 5.0 Electrical requirements

### 5.1 Power supply

**5.1.1 VDD 18** – Main 1.8V always ON power input. Refer to the Designer's Notes for more details.

Noise and ripple requirements are:

Supply voltage: Nominal 1.8V, +50mV, -50mV.

0-3MHz range, less than 50mV peak to peak noise.

>3MHz range, less than 15mV peak to peak noise.

**Note:** protected by POR, which will force the GPS receiver into Hibernate mode, if triggered. It will require an ON pulse to wake it up again.

Sufficient low ESR capacitance is required and the 1.8V supply must have low source impedance to prevent the 1.8V rail POR to trigger when the module is started up via the ON-OFF line. This causes inrush current that can cause the 1.8V supply to drop.

Refer to the Designer's Notes for information on designing a suitable system.

#### 5.1.2 External antenna voltage

The J-F2 requires an external antenna Bias-T to provide the voltage to the antenna. This is detailed in the Designer's Notes.

#### 5.1.3 RF (Radio Frequency) input

RF input is 1575.42 MHz (L1 Band) at a level between -135 dBm and -165 dBm into a 50 Ohm impedance.

#### 5.1.4 Antenna gain

The receiver will operate with a passive antenna with Isotropic gain down to a minimum of -6dBi. Active antenna are supported. The internal LNA must be switched to low gain mode if an active antenna is used.

An active antenna of 20dB minimum (exiting the cable) will offer the best performance. 30dB exiting the antenna cable is maximum useable active antenna gain.

Refer to section 2.11 for more details.

Contact NAVMAN for in depth passive antenna design support.

#### 5.1.5 Burnout protection

The receiver accepts without risk of damage a signal of +10 dBm from 0 to 2 GHz carrier frequency, except in band 1560 to 1590 MHz where the maximum level is -10 dBm.

#### 5.1.6 Jamming performance

Eight separate in band jammers can be detected and digitally removed in the GPS DSP. This is over and above the excellent SAW filter response that exists before the GPS LNA input.

**Note:** The spectral purity of oscillators and RF transmitters in the host system will determine if harmonics are formed that are equal to the frequencies above.

Compact wireless product design requires close monitoring of jamming issues.

Contact Navman for assistance especially if designing with a passive GPS antenna.

### 5.1.7 Flash upgradability

The firmware programmed in the Flash memory may be upgraded via the serial port TX/RX pads. The user can control this by driving the Serial BOOT select line high at startup, then downloading the code from a PC with suitable software (SiRFFlash). In normal operation this pad should be left floating for minimal current drain. It is recommended that in the user's application, the BOOT select pad is connected to a test pad for use in future software upgrades. Refer to the Designer's Notes for additional information.

### 5.1.8 Reset input

This active low input to NSRESET. No user POR is required. It is recommended to not use or connect to this pin, except as indicated by NAVMAN.

The module contains a POR that monitors the 1.8V supply. This POR has strict criteria to ensure system software reliability. If this signal is triggered by low voltage on the 1.8V supply the J-F2 will drop into Hibernate mode and the patch RAM and CGEE will be cleared. The J-F2 will require an ON pulse once the supply has stabilized to wake up the GPS receiver and return to a full power state (CGEE must be reloaded). If the supply voltage drops low enough for a long enough period of time the RAM/BBRAM will be cleared and the GPS will carry out a Cold start once woken up.

**Note:** If the voltage drops low enough to affect the RAM/BBRAM/PATCH RAM and the 1.8V POR has triggered, all power must be removed from the module for a minimum of 10 seconds to ensure the memory is cleared of all corrupted data. It is strongly recommend a 1.8V back up supply is used to ensure this does not happen. The 1.8V back up supply (14uA typical) will take over once the GPS has been shut down into Hibernate mode via the 1.8V rail POR as the main 1.8V supply inadvertently drops. Enough isolation is required on the main 1.8V supply to prevent current draining back through the main 1.8V supply and cause memory corruption. Review the Designer's Note for more details.

It is important that the always ON 1.8V is primary design consideration and must be maintained as much as possible.

Review the Designer's Note for in depth information on the 1.8V supply requirements.

## 5.2 Data input output specifications

All communications between the J-F2 receiver and external devices are through the I/O surface mount pads. These provide the contacts for power, ground, serial I/O and control. Power requirements are discussed in Section 5.1.

## 5.2.1 Voltages and currents

Parameter	Symbol	Min	Typ	Max	Unit
Power Supply Voltage <sup>(1)(3)</sup>	VDD	1.75	1.8	1.90	V
Operating Temperature <sup>(2)</sup>	T <sub>OPR</sub>	-40		85	°C
Navigating current consumption <sup>(4)</sup>					
Low gain mode			34		mA
High gain mode			38		mA
1Hz Trickle power current <sup>(4)</sup>			13		mA
Hibernate current			<14		uA

**Table 3. Power requirements**

### Notes

- Power must be **always** applied. The GPS will control its own power consumption depending on the required power configuration. The ON-OFF pin must be used to power the GPS OFF and ON. .
- Operating temperature is ambient.
- Ripple characteristics must be ensured for best GPS performance and reliable operation. The 1.8V POR has strict requirements and will shut the GPS down if these minimum specifications are not maintained.
- This is in LDO mode. Default power mode on power application and start up.

**Note: Allowable ripple on the 1.8V supply is <50mV (0-3MHz) and <16mV above 3MHz. This is WITH the GPS and all systems running.**

### Absolute Maximum Ratings

Parameter	Symbol	Rating	Units
Power Supply Voltage	VDD	2.2	V
Input Pin Voltage	VIO_IN	3.6	V
Output Pin Voltage	VIO_OUT	3.6	V
Storage Temperature	T <sub>stg</sub>	-50 to 150	°C

**Table 4. Digital Core and I/O voltage (Volatile)**

**Warning – Stressing the device beyond the “Absolute Maximum Ratings” may cause permanent damage. These are stress ratings only. Operation beyond the “Operating Conditions” is not recommended and extended exposure beyond the “Operating Conditions” may affect device reliability.**

Parameter	Symbol	Min	Typ	Max	Unit
Low level output voltage Text conditions I <sub>oi</sub> = 2mA and 4.0mA <sup>(a)</sup>	V <sub>oi</sub>	–	–	0.40	V
High level output voltage Text conditions I <sub>oi</sub> = 2mA and 4.0mA <sup>(a)</sup>	V <sub>oh</sub>	0.75 x VDD	–	–	V
Low level input voltage	V <sub>il</sub>	–0.4	–	0.45	V
High level input voltage	V <sub>ih</sub>	0.7 x VDD	–	3.6	V
Internal pull-up resistor Equivalent	R <sub>pu</sub>	50	86	157	kΩ
Internal pull-down resistor Equivalent	R <sub>pd</sub>	51	91	180	kΩ
Input leakage at V <sub>i</sub> = 1.8V or 0V	I <sub>i</sub>	–10	–	10	μA
Tristate output leakage at V <sub>o</sub> = 1.8V or 0V	I <sub>oz</sub>	–10	–	10	μA
Input capacitance	C <sub>in</sub>	–	5	–	pF
Output capacitance	C <sub>load</sub>	–	–	–	pF

**Table 5. DC Electrical Characteristics**

**Note:** VDD=1.8V

## 5.2.2 I/O surface mount pads

Details of the LGA pad functions are shown in Table 6.

Pad Number	Pad function	Type	Description
1	GND	PWR	Ground
2	NC	-	No connection
3	NC	-	No connection
4	NC	-	No connection
5	SYSTEM-ON	O	Indication that GPS is running (Active high)
6	NC	-	No connection
7	GND	PWR	Ground
8	RF IN	I	GPS RF input
9	GND	PWR	Ground
10	TX	O	UART/SPI/I2C (1.8V)
11	RX	I	UART/SPI/I2C (3.6V tolerant)
12	NSRESET	I	GPS Reset (Active low)
13	ON-OFF	I	I/O line to turn GPS ON or OFF (Active high pulse)
14	NC	-	No connection
15	GPIO4	I/O	General Purpose Input/Output
16	NC	-	No connection
17	BOOT / NC	I	Flash program select (Active High). No connect for ROM devices.
18	GPIO2	I/O	General Purpose Input/Output
19	GPIO3	I/O	General Purpose Input/Output
20	NC	-	No connection
21	GND	PWR	Ground
22	NC	-	No connection
23	GPIO6	I/O	General Purpose Input/Output
24	GPIO7	I/O	General Purpose Input/Output
25	VDD 18	PWR	Redundent supply input, 1.8V. Connect to Pin 32.
26	GPIO8	I/O	General Purpose Input/Output
27	NC	-	No connection
28	TM	O	1PPS time pulse (1.8V)
29	GPIO0	I/O	General Purpose Input/Output
30	GPIO1	I/O	General Purpose Input/Output
31	GND	PWR	GROUND
32	VDD 18	PWR	Main supply voltage input ,1.8V (ALWAYS ON)

**Table 6. LGA pad functions**

**Note:** follow the design recommendations

**Note:** GPIO/UART/SPI/I2C/DR\_I2C voltages and levels are based on 1.8V.

## 6.0 Software interface

---

The host serial I/O port of the receiver's serial data interface supports full duplex communication between the receiver and the user.

The default serial modes are as follows:

UART: NMEA, 4800 bps, 8 data bits, no parity, 1 stop bit

### 6.1 NMEA output messages

NMEA v3.0 is the default protocol. The following messages are output once per second:

RMC = 1 second update

GGA = 1 second update

GSA = 1 second update

GSV = 4 second update when fix obtained.

Reference the NMEA protocol manual for additional message details.

### 6.2 SiRF OSP output messages

SiRF One Socket Protocol (OSP) is supported. This is an extension of the existing SiRF Binary protocol.

The following messages are output once per second:

MID 7

MID 64 SUB ID 2 – One message for each satellite being tracked.

MID41

MID4

MID3

MID138

MID2

MID9

Reference the SiRF One Socket Protocol manual for additional message details.



## 6.3 Software functions and capabilities

Table 7 shows the software features available to the J-F2.

Feature	Description	Availability
SBAS	Improves position accuracy by using freely available satellite based correction services called SBAS (Satellite Based Augmentation System)	A
Adaptive Trickle Power	Improves battery life by using enhanced power management and intelligently switching between low and full power depending on the current GPS signal level. Refer to the Low Power Operating Modes application note.	A
Push to Fix mode	Provides an on-demand position fix mode designed to further improve battery life compared to ATP.	A
Micro Power Management	Advanced power management with integrated switched-mode regulation to maintain hot-start conditions with minimal energy.	A
Advanced Power Management	Allows many system triggers to be set to ensure the lowest power consumption is achieved with the required number of fixes and quality of fixes.	A
Almanac to Flash	Improves cold start times by storing the most recent almanac to flash memory.	Yes
Low signal acquisition	Acquires satellites and continues tracking in extremely low signal environments.	Yes
Low signal navigation	Continues navigating in extremely low signal environments.	Yes
Time Mark (1PPS)	A timing signal generated every second on the second.	Yes
MEMS	Sensor based Dead Reckoning without valid GPS signals	A
Antenna Supervision	Active antenna short circuit and open circuit detection/ control, software supported.	A
SGEE	AGPS using predicted ephemeris data from a server. Supporting Host required.	Yes
CGEE	AGPS using prediction of ephemeris from live (downloaded from satellites), ephemeris stored in memory.	Yes
Active jammer detect	System scan for up to 8 jammers for removal by the GPS	A
Yes = always enabled      A = available, but not enabled by default		

**Table 7. Software features**

yes = always enabled      A = available, but not enabled by default

## 7.0 Mechanical drawing

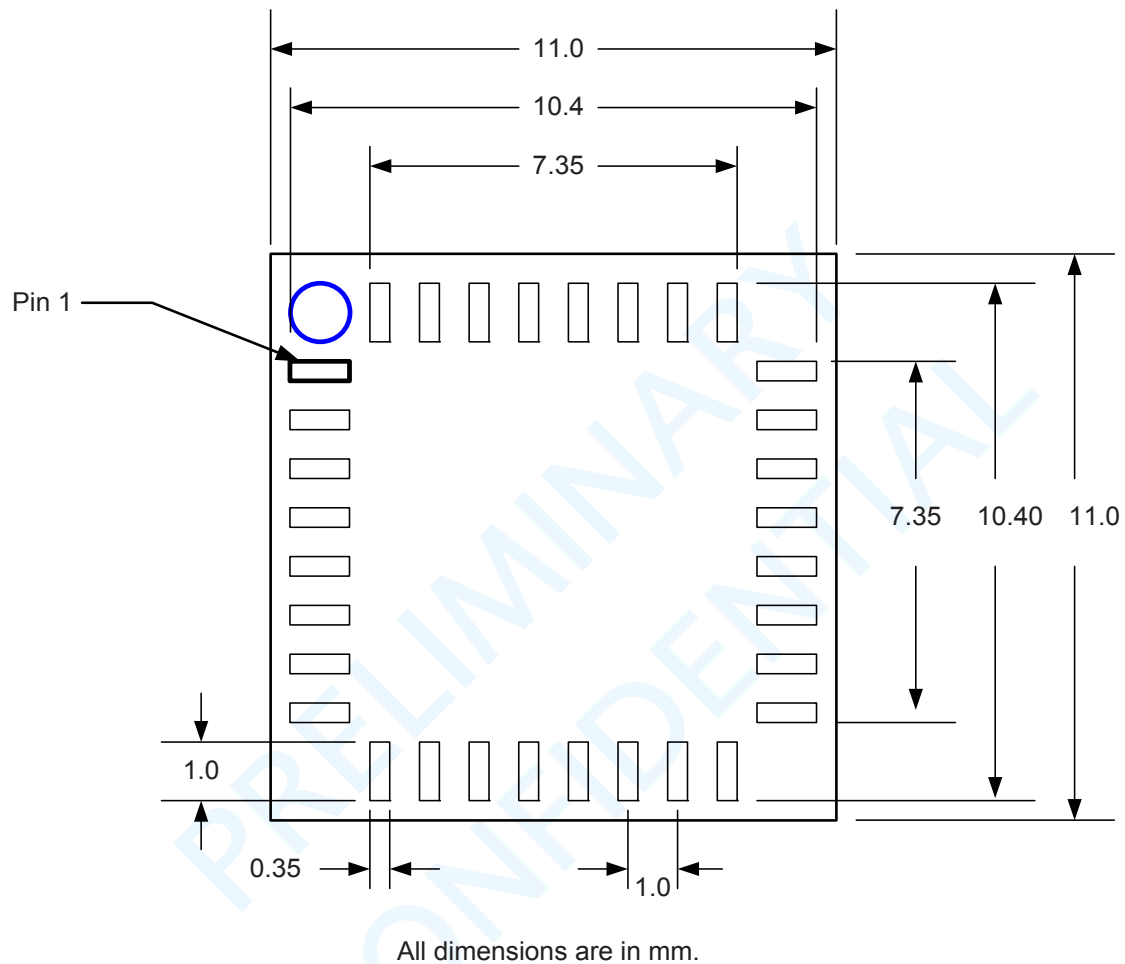

Figure 2. Mechanical layout (Top View)

Bottom pad pin outs as viewed from the top through to the bottom.

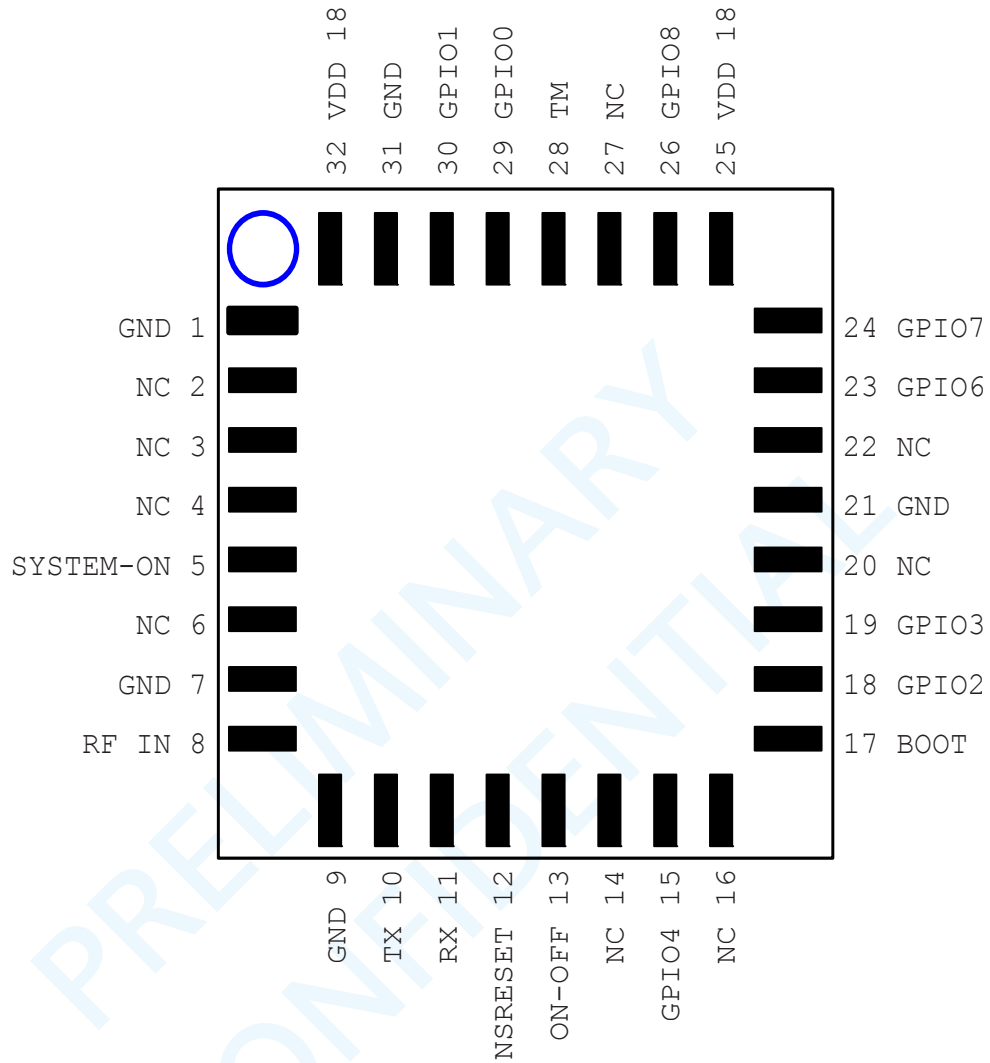

Figure 3. Pinout (Top View)

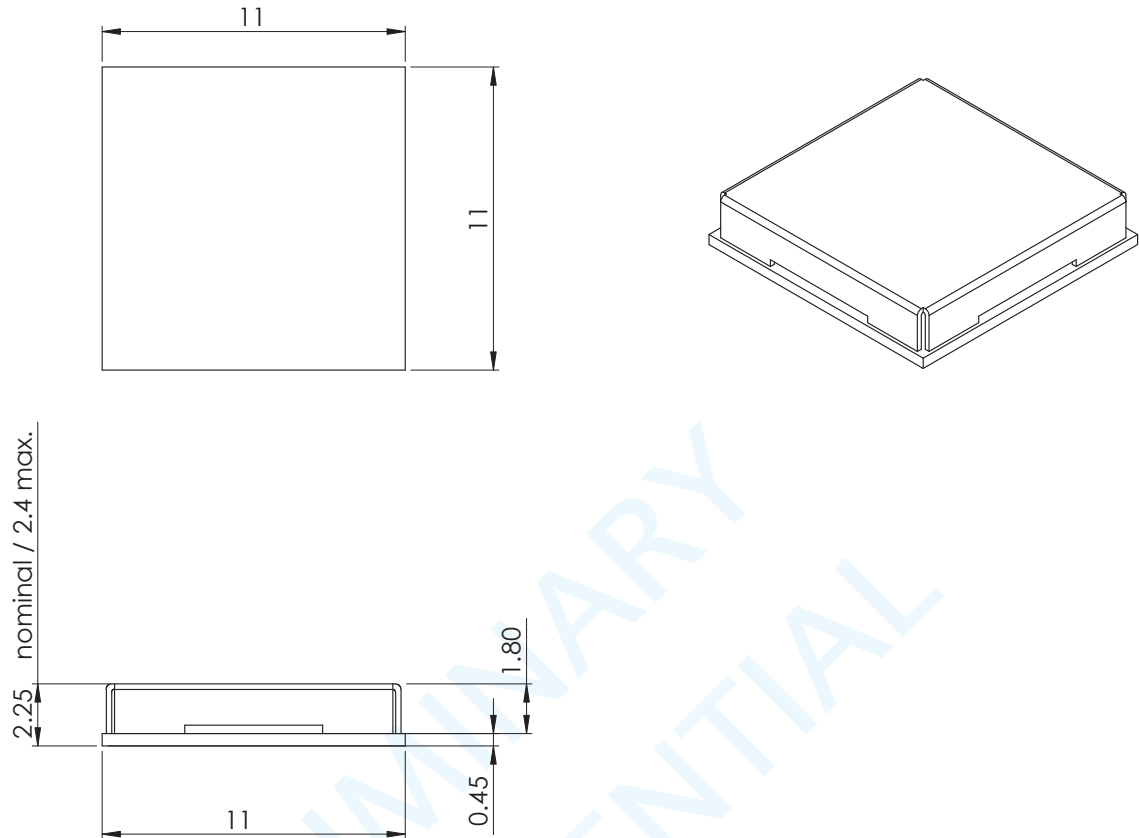

Figure 4. 3D Model

## 8.0 Evaluation kit

The J-F2 Development Kit is available to assist in the evaluation and integration of the J-F2 module in custom applications. The Development Kit contains all of the necessary hardware and software to carry out a thorough evaluation of the J-F2 module.

## 9.0 Product handling

### 9.1 Product packaging and delivery

J-F2 modules are shipped in Tape and Reel form. The reeled modules are shipped in 24mm reels with 1000 units per reel. Each reel is 'dry' packaged and vacuum sealed in an Moisture Barrier Bag (MBB) with two silica gel packs and placed in a carton.

The minimum order quantity for shipping is 1000 units. Refer to the Designer's Notes for additional details.

All packaging is ESD protective lined. The J-F2 GPS receiver is a Moisture Sensitive Device (MSD) level 3. Please follow the MSD and ESD handling instructions on the labels of the MBB and exterior carton (refer to sections 9.2 and 9.3).

## 9.2 Moisture sensitivity

Precautionary measures are required in handling, storing and using such devices to avoid damage from moisture absorption. If localized heating is required to rework or repair the device, precautionary methods are required to avoid exposure to solder reflow temperatures that can result in performance degradation.

Further information can be obtained from the IPC/JEDEC standard *J-STD-033: Handling, Packing, Shipping and Use of Moisture/Reflow Sensitive Surface Mount Devices*.

## 9.3 ESD sensitivity

The J-F2 GPS receiver contains class 1 devices and is Electro-Static Discharge Sensitive (ESDS). Navman recommends the two basic principles of protecting ESD devices from damage:

Only handle sensitive components in an ESD Protected Area (EPA) under protected and controlled conditions

Protect sensitive devices outside the EPA using ESD protective packaging All personnel handling ESDS devices have the responsibility to be aware of the ESD threat to the reliability of electronic products.

Further information can be obtained from the IEC Technical Report *IEC61340-5-1 & 2: Protection of electronic devices from electrostatic phenomena*.

## 9.4 Safety

Improper handling and use of the Jupiter GPS receiver can cause permanent damage to the receiver. There is also the possible risk of personal injury from mechanical trauma or choking hazard.

## 9.5 Disposal

We recommend that this product should not be treated as household waste. For more detailed information about recycling this product, please contact your local waste management authority or the reseller from whom you purchased the product.

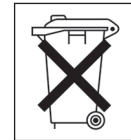

## 10.0 Ordering information

---

J-F2.0000.TR	J-F2 Module (TR = tray)
J-F2.0000.TP	J-F2 Module (TP = tape and reel)
J-F2.0000.EK	J-F2 Evaluation Kit

NOTE: 0000 denotes software version.

### 11.0 Glossary and acronyms

**Almanac:** A set of orbital parameters that allows calculation of approximate GPS satellite positions and velocities. The almanac is used by a GPS receiver to determine satellite visibility and as an aid during acquisition of GPS satellite signals. The almanac is a subset of satellite ephemeris data and is updated weekly by GPS Control.

**CGEE:** Client Generated Extended Ephemeris data. AGPS using prediction of ephemeris from live (downloaded from satellites), ephemeris stored in memory.

**DGPS:** Differential GPS

A technique to improve GPS accuracy that uses pseudo-range errors recorded at a known location to improve the measurements made by other GPS receivers within the same general geographic area.

**EGNOS:** European Geostationary Navigation Overlay Service

The system of geostationary satellites and ground stations developed in Europe to improve the position and time calculation performed by the GPS receiver.

**Ephemeris plural ephemerides:** A set of satellite orbital parameters that is used by a GPS receiver to calculate precise GPS satellite positions and velocities. The ephemeris is used to determine the navigation solution and is updated frequently to maintain the accuracy of GPS receivers.

**ESD:** Electro-Static Discharge

large momentary unwanted currents that cause damage to electronic equipment.

**GDOP:** Geometric Dilution of Precision

A factor used to describe the effect of the satellite geometry on the position and time accuracy of the GPS receiver solution. The lower the value of the GDOP parameter, the less the error in the position solution. Related indicators include PDOP, HDOP, TDOP and VDOP.

**GPS:** Global Positioning System

A space-based radio positioning system that provides accurate position, velocity, and time data.

**InstantFix:** Eliminates the initial delay of obtaining GPS satellite location data from the satellites themselves by using algorithms to predict seven days of satellite location data.

**LGA:** Land Grid Array

A physical interface for microprocessors. There are no pins on the chip; in place of the pins are pads of bare gold-plated copper that touch pins on the motherboard.

**MSD:** Moisture sensitive device.

**NMEA:** National Marine Electronics Association

**OEM:** Original Equipment Manufacturer

**POR:** Power On Reset.

**SBAS:** Satellite Based Augmentation System

Any system that uses a network of geostationary satellites and ground stations to improve the performance of a Global Navigation Satellite System (GNSS). Current examples are EGNOS and WAAS.

**SGEE:** Server Generated Extended Ephemeris data. AGPS using predicted ephemeris data from a server. Supporting Host required.

**WAAS:** Wide Area Augmentation System

The system of satellites and ground stations developed by the FAA (Federal Aviation Administration) that provides GPS signal corrections. WAAS satellite coverage is currently only available in North America.

© 2011 Navman Wireless OEM. All Rights Reserved.

SiRF and SiRF logo are registered trademarks of SiRF Technology, Inc. SiRFstar, Push-to-Fix, and Trickle-Power are trademarks of SiRF Technology, Inc. All other trademarks mentioned in this document are property of their respective owners.

Information in this document is provided in connection with Navman Wireless OEM ('Navman') products. These materials are provided by Navman as a service to its customers and may be used for informational purposes only. Navman assumes no responsibility for errors or omissions in these materials. Navman may make changes to specifications and product descriptions at any time, without notice. Navman makes no commitment to update the information and shall have no responsibility whatsoever for conflicts or incompatibilities arising from future changes to its specifications and product descriptions. No license, express or implied, by estoppel or otherwise, to any intellectual property rights is granted by this document. Except as provided in Navman's Terms and Conditions of Sale for such products, Navman assumes no liability whatsoever.

THESE MATERIALS ARE PROVIDED 'AS IS' WITHOUT WARRANTY OF ANY KIND, EITHER EXPRESSED OR IMPLIED, RELATING TO SALE AND/OR USE OF NAVMAN PRODUCTS INCLUDING LIABILITY OR WARRANTIES RELATING TO FITNESS FOR A PARTICULAR PURPOSE, CONSEQUENTIAL OR INCIDENTAL DAMAGES, MERCHANTABILITY, OR INFRINGEMENT OF ANY PATENT, COPYRIGHT OR OTHER INTELLECTUAL PROPERTY RIGHT. NAVMAN FURTHER DOES NOT WARRANT THE ACCURACY OR COMPLETENESS OF THE INFORMATION, TEXT, GRAPHICS OR OTHER ITEMS CONTAINED WITHIN THESE MATERIALS. NAVMAN SHALL NOT BE LIABLE FOR ANY SPECIAL, INDIRECT, INCIDENTAL, OR CONSEQUENTIAL DAMAGES, INCLUDING WITHOUT LIMITATION, LOST REVENUES OR LOST PROFITS, WHICH MAY RESULT FROM THE USE OF THESE MATERIALS.

Navman products are not intended for use in medical, lifesaving or life sustaining applications. Navman customers using or selling Navman products for use in such applications do so at their own risk and agree to fully indemnify Navman for any damages resulting from such improper use or sale. Product names or services listed in this publication are for identification purposes only, and may be trademarks of third parties. Third-party brands and names are the property of their respective owners. Additional information, posted at [www.navmanwirelessoem.com](http://www.navmanwirelessoem.com), is incorporated by reference. Reader response: Navman strives to produce quality documentation and welcomes your feedback. Please send comments and suggestions to [Americastechsupport@navmanwirelessoem.com](mailto:Americastechsupport@navmanwirelessoem.com). For technical questions, contact your local Navman sales office or field applications engineer.

PRELIMINARY  
CONFIDENTIAL