

MeshConnect™ Sub-G Module Series

ZICM0868P0
ZICM0900P2
868 / 900 MHz System-on-Chip (SoC) Based Modules
Development Kits Available:
ZICM0868P0-KIT1-1 and ZICM0900P2-KIT1-1

DESCRIPTION

CEL's MeshConnect™ Sub-G modules are built on the Si1000 and Si1002 highly integrated wireless SoC's from Silicon Labs. Targeting dense operating environments, CEL's MeshConnect Sub-G modules deliver superior range and performance. Their low power consumption enables longer battery life and their link budgets provide reliable transmission in non line of sight applications such as lighting control, industrial sensor networks, serial wire replacement, metering, irrigation and more. At +13 and +20 dBm power outputs, the new Sub-G modules offer 868 MHz (Europe) and 915 MHz (Americas) ISM band options. As certified and qualified modules, the MeshConnect Sub-G solutions eliminate the need for costly certifications, reducing overall system cost and accelerating time to market.

APPLICATIONS

- Lighting Control
- Irrigation
- Serial wire replacement
- Industrial Sensor Networks
- Wireless M-Bus Metering
- Home Automation & Smart Plugs
- Security
- And more...

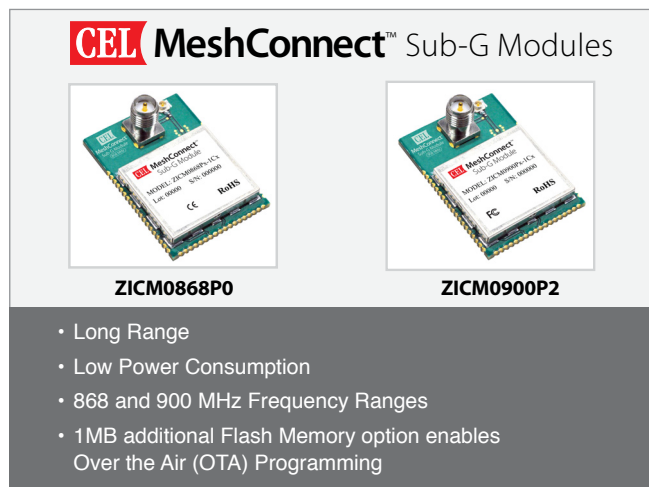

- Long Range
- Low Power Consumption
- 868 and 900 MHz Frequency Ranges
- 1MB additional Flash Memory option enables Over the Air (OTA) Programming

FEATURES

- **Frequency Range:**
902-928 MHz
868 MHz
- **Link Budget up to -140 dB**
(for +20 dBm module)
+20 dBm and +13 dBm available output powers
- **Max Output Power:**
+13 dBm @ 3.5 VDC (ZICM0868P0)
+20 dBm @ 3.5 VDC (ZICM0900P2)
- **Data Rate: 0.123 to 150 kbps**
- **General Purpose I/Os: 21**
- **High Speed 8051 MCU:**
25 MHz - single cycle instruction execution
4kB RAM / 64 kB Flash
- **10-Bit ADC:**
300 ksps, 18-ch inputs
- **Serial Communication:**
UARTs, SPI (Master/Slave)
SMBus, PCA
- **Add 1MB additional Flash memory to enable Over The Air (OTA) programming** (Optional)
- **Modulation:**
FSK, GFSK, OOK
- **RF Power Consumption**
24 mA Receive
18 mA @ +1 dBm transmit
42 mA @ +13 dBm transmit
97 mA @ +19 dBm transmit
- **Sleep Current 1.2 µA TYP**
- **Up to 6 miles of range**
(line of sight)
- **Operating Temperature Range:**
-40 to +85°C
- **Software Platforms:**
Synapse SNAP Embedded Firmware
Wireless M-Bus (868 MHz Only)
CEL Application Programming Interface (API)
Silicon Labs EZMac
- **FCC, CE and IC certifications in Progress**
Multiple antenna options
FSK Modulation Only
- **ROHS compliant**

ORDERING INFORMATION

| Part Number | Order Number | Description |
|--|--------------------------|---|
| MeshConnect™ Sub-G Module (868 MHz) | ZICM0868P0-1CU | 868 MHz Module, +13dBm SoC with U.FL connector for external antenna |
| | ZICM0868P0-1CS | 868 MHz Module, +13dBm SoC with RP-SMA connector for external antenna |
| | ZICM0868P0-1C | 868 MHz Module, +13dBm SoC with 1/4 wave wire antenna |
| MeshConnect™ Sub-G Module (902-928 MHz) | ZICM0900P2-1CU | 900 MHz Module, +20dBm SoC with U.FL connector for external antenna |
| | ZICM0900P2-1CS | 900 MHz Module, +20dBm SoC with RP-SMA connector for external antenna |
| | ZICM0900P2-1C | 900 MHz Module, +20dBm SoC with 1/4 wave wire antenna |
| | ZICM0900P2-1CU-SN | 900 MHz Module, +20dBm SoC with U.FL connector for external antenna with SNAP Operating System software |
| | ZICM0900P2-1CS-SN | 900 MHz Module, +20dBm SoC with RP-SMA connector for external antenna with SNAP Operating System software |
| | ZICM0900P2-1C-SN | 900 MHz Module, +20dBm SoC with 1/4 wave wire antenna with SNAP Operating System software |
| MeshConnect™ Sub-G Development Kits | ZICM0868P0-KIT1-1 | 868 MHz Evaluation board for +13dBm SoC module |
| | ZICM0900P2-KIT1-1 | 900 MHz Evaluation board for +20dBm SoC module |

MODULE BLOCK DIAGRAM

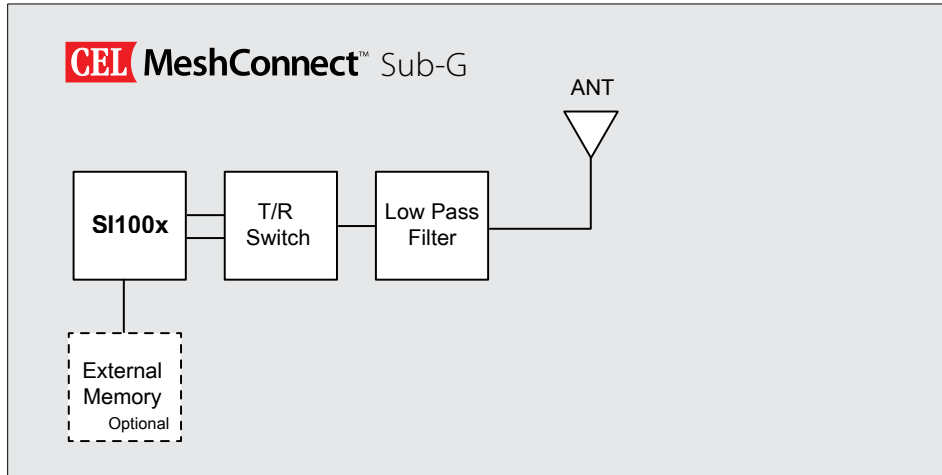

DEVELOPMENT KIT

CEL's Development Kit assist users in both evaluation and development. As a stand-alone radio system, the kit allows users to place the modules into the target environment and evaluate performance on-site. The Development Kit also serves as an invaluable aid in application development. Through the many interface headers on the board, the user has access to all of the MeshConnect module pins, enabling easy connection to target systems for application development.

The interface board features a serial communication interface, a power management module, and peripherals such as a buzzer, push-button switches, LEDs, and GPIO headers.

For more detail information regarding MeshConnect Development Kits, refer to the respective development kit user guides documents. (Available at CEL's website: www.cel.com/MeshConnect)

CEL MeshConnect™

Sub-G Module Development Kit



- Kit Contents:**
- Evaluation Boards (2)
 - MeshConnect Sub-G Modules w/Daughter Cards (2)
 - Modules with RPSMA connectors and 0dBi whip Antennas (2)
 - USB Debug Adaptor (1)
 - USB Cables (1)
 - AA Batteries (4)
 - Software & Technical Information/Documentation CD (1)

DEVELOPMENT KIT ORDERING INFORMATION

| Part Number | Order Number | Description |
|-------------------------------------|-------------------|--|
| MeshConnect™ Sub-G Development Kits | ZICM0868P0-KIT1-1 | 868 MHz Evaluation board for +13dBm SoC module |
| | ZICM0900P2-KIT1-1 | 900 MHz Evaluation board for +20dBm SoC module |

TABLE OF CONTENTS

Introduction and Overview

| | |
|---------------------------|---|
| Description..... | 1 |
| Features..... | 1 |
| Applications..... | 1 |
| Ordering Information..... | 2 |
| Module Block Diagram..... | 3 |
| Development Kit..... | 3 |

System Level Function

| | |
|------------------------------|---|
| Transceiver IC..... | 5 |
| Antenna..... | 5 |
| Additional Flash Memory..... | 5 |

Electrical Specification

| | |
|--|---|
| Absolute Maximum Ratings..... | 6 |
| Recommended (Operating Condition)..... | 6 |
| DC Characteristics..... | 6 |
| RF Characteristics..... | 4 |

Pin Signal & Interfaces

| | |
|------------------------------------|----|
| Pin Signals I/O Configuration..... | 8 |
| I/O Pin Assignment..... | 8 |
| Software/Firmware..... | 9 |
| Module Dimensions..... | 10 |
| Module Footprint..... | 11 |

| | |
|-----------------|----|
| Processing..... | 12 |
|-----------------|----|

| | |
|----------------------------|----|
| Agency Certifications..... | 13 |
|----------------------------|----|

| | |
|-----------------------------------|----|
| Shipment, Storage & Handling..... | 15 |
|-----------------------------------|----|

| | |
|--------------|----|
| Quality..... | 15 |
|--------------|----|

| | |
|------------------------------------|----|
| References & Revision History..... | 16 |
|------------------------------------|----|

TRANSCEIVER IC

The MeshConnect Sub-G modules are based on the Silicon Labs Si1000 and Si1002 wireless SoCs ICs. These devices incorporate the RF transceiver with the baseband modem, a hardwired MAC, and an embedded 8051 microcontroller, offering a high performance solution for all Sub-G applications.

For more information about the Silicon Labs ICs, visit <http://www.silabs.com>.

ANTENNA

The MeshConnect Sub-G modules include RF connectors for external antenna options only (There is no trace antenna option). The following options are supported by CEL:

- U.FL connector to support cabled antenna
- RP-SMA connector
- 1/4 wave wire antenna in place of RP-SMA

Here are some design guidelines to help ensure antenna performance:

- Never place the antenna close to metallic objects.
- In the overall design, ensure that wiring and other components are not placed near the antenna.
- Do not place the antenna in a metallic or metalized plastic enclosure.
- Keep plastic enclosures 1cm or more from the antenna in any direction.
- Antenna performance may be improved if module is mounted on carrier board with large ground plane (3 in x 3in) provided clearance is allowed for center pin of RPSMA or Wire

ADDITIONAL FLASH MEMORY (Optional)

The Silicon Labs Transceiver ICs (Si1000 and Si1002) have an embedded 64kB of flash. Additional Flash memory (1MB) can be mounted on each module (as an option) to enable Over The Air (OTA) programming capability. This option is available for all part numbers, but must be specified at the time of ordering.

ABSOLUTE MAXIMUM RATINGS

| Description | MeshConnect™ Sub-G Module | | Unit |
|------------------------------|---------------------------|-----------|------|
| | Min | Max | |
| Power Supply Voltage (VDD) | -0.3 | 3.6 | VDC |
| Voltage on any I/O Line | -0.3 | VDD + 0.3 | VDC |
| RF Input Power | – | 10 | dBm |
| Storage Temperature Range | -40 | 125 | °C |
| Reflow Soldering Temperature | – | 260 | °C |

Note: Module has built in Tx disabling feature when VCC = 3.6VDC.
Exceeding the maximum ratings may cause permanent damage to the module or devices.

RECOMMENDED (OPERATING CONDITIONS)

| Description | MeshConnect™ Sub-G Module | | | Unit |
|------------------------------|---------------------------|-----|-----|------|
| | Min | Typ | Max | |
| Power Supply Voltage (VDD) | 1.8/2.7* | 3.3 | 3.5 | V |
| Frequency Range (ZICM0868P0) | 865 | – | 870 | MHz |
| Frequency Range (ZICM0900P2) | 902 | – | 928 | MHz |
| Ambient Temperature Range | -40 | 25 | 85 | °C |

Note: * 2.7v is the min voltage if an additional memory IC was ordered.

DC CHARACTERISTICS (@ 25°C, VDD = 3.5V, ZICM0868P0 TX power max)

| Description | MeshConnect™ Sub-G Module | | | Unit |
|---------------------------------|---------------------------|-----|-----|------|
| | Min | Typ | Max | |
| Transmit Mode Current (@ 13dBm) | – | 42 | – | mA |
| Receive Mode Current | – | 24 | – | mA |
| Sleep Mode Current | – | 1.2 | – | µA |

DC CHARACTERISTICS (@ 25°C, VDD = 3.5V, ZCM0900P2 TX power max)

| Description | MeshConnect™ Sub-G Module | | | Unit |
|--------------------------------|---------------------------|-----|-----|------|
| | Min | Typ | Max | |
| Transmit Mode Current(@ 20dBm) | – | 97 | – | mA |
| Receive Mode Current | – | 24 | – | mA |
| Sleep Mode Current | – | 1.2 | – | µA |

RF CHARACTERISTICS (@ 25°C, VDD = 3.5V, ZICM0868P0)

| Description | MeshConnect™ Sub-G Module | | | Unit |
|----------------------------------|---------------------------|-----|-----|------|
| | Min | Typ | Max | |
| General Characteristics | | | | |
| RF Frequency Range | 865 | – | 870 | MHz |
| Transmitter | | | | |
| Maximum Output Power | – | 13 | – | dBm |
| Minimum Output Power | – | -12 | – | dBm |
| FSK Error | – | 15 | – | % |
| Deviation | – | 75 | – | KHz |
| Receiver | | | | |
| Sensitivity (1% PER, 150kbps) | – | -99 | – | dBm |
| Saturation (maximum input level) | – | – | 10 | dBm |

RF CHARACTERISTICS (@ 25°C, VDD = 3.5V, ZICM0900P2)

| Description | MeshConnect™ Sub-G Module | | | Unit |
|----------------------------------|---------------------------|-----|-----|------|
| | Min | Typ | Max | |
| General Characteristics | | | | |
| RF Frequency Range | 902 | – | 928 | MHz |
| Transmitter | | | | |
| Maximum Output Power | – | 19 | – | dBm |
| Minimum Output Power | – | -5 | – | dBm |
| FSK Error | – | 15 | – | % |
| Deviation | – | 75 | – | KHz |
| Receiver | | | | |
| Sensitivity (1% PER, 150kbps) | – | -99 | – | dBm |
| Saturation (maximum input level) | – | – | 10 | dBm |

PIN SIGNALS I/O PORT CONFIGURATION

MeshConnect module has 56 edge I/O interfaces for connection to the user's host board. The MeshConnect Module Dimensions shows the layout of the 56 edge castellations.

MeshConnect I/O PIN ASSIGNMENTS

| Number | Name | Notes | SI100x Pin |
|--------|-----------------|---|------------|
| 1 | GND | | |
| 2 | GND | | |
| 3 | GND | | |
| 4 | GND | | |
| 5 | GND | | |
| 6 | GND | | |
| 7 | GND | | |
| 8 | NC | | |
| 9 | ANTA | Available: Not used for any module functionality | 21 |
| 10 | GPIO0 | Available: Not used for any module functionality | 24 |
| 11 | GPIO2 | Available: Not used for any module functionality | 26 |
| 12 | P0.7/IREF | Internally connected to SDN | 29 |
| 13 | P0.6/ CNVSTR | Used as Chip Select for Memory on CEL Eval. Board | 30 |
| 14 | P0.5/RXD | Module's Internal UART RXD | 31 |
| 15 | P0.4/TXD | Module's UART TXD | 32 |
| 16 | WP | Write Protect Pin of Memory Chip on Module | N/A |
| 17 | NC | | |
| 18 | GND | | |
| 19 | GND | | |
| 20 | NC | | |
| 21 | NC | | |
| 22 | NC | | |
| 23 | P0.3 | Used as Chip Select for Memory IC on the CEL Module | 33 |
| 24 | P0.2 | Memory IC MISO signal pin | 34 |
| 25 | P0.1 | Connected to NIRQ | 35 |
| 26 | P0.0 | Memory IC Clock Signal | 36 |
| 27 | GND | | 23, 37 |
| 28 | VCC | | 28, 38 |
| 29 | RST/C2CK | Debug Clock | 39 |
| 30 | P2.7/C2D | Debug Data | |
| 31 | P2.6 | GPIO connected to Buzzer on CEL Eval Board | 41 |
| 32 | P2.5 | GPIO connected to Switch 3 on CEL Eval board | 2 |
| 33 | P2.4 | GPIO connected to LED3 on CEL Eval board | 3 |

MeshConnect I/O PIN ASSIGNMENTS (Continued)

| Number | Name | Notes | SI100x Pin |
|--------|------|---|------------|
| 34 | P2.3 | GPIO connected to Switch 2 on CEL Eval Board | 4 |
| 35 | NC | | |
| 36 | NC | | |
| 37 | GND | | |
| 38 | GND | | |
| 39 | GND | | |
| 40 | GND | | |
| 41 | GND | | |
| 42 | P2.2 | GPIO connected to LED2 on CEL Eval board | 5 |
| 43 | P2.1 | GPIO connected to Switch 1 on CEL Eval Board | 6 |
| 44 | P2.0 | GPIO connected to LED1 on CEL Eval board | 7 |
| 45 | P1.7 | GPIO connected to Switch 0 on CEL Eval Board | 8 |
| 46 | P1.6 | GPIO connected to LED0 on CEL Eval board | 9 |
| 47 | P1.5 | Memory IC MOSI | 10 |
| 48 | NIRQ | External Interrupt Request. This is internally connected to P0.1 for SNAP firmware to be operational. | 11 |
| 49 | SDN | Radio Shutdown (Active High); Internally connected to P0.7 | 15 |
| 50 | GND | | |
| 51 | GND | | |
| 52 | GND | | |
| 53 | GND | | |
| 54 | GND | | |
| 55 | GND | | |
| 56 | GND | | |

Note: The CEL Sub G module has internal connections between Castellations Pins 12 & 49 and 25 & 48 to allow stand alone operation with both SNAP and CEL firmware images.

SOFTWARE/FIRMWARE

The Sub-G modules support the following software:

- Synapse SNAP Embedded Firmware
- Wireless M-Bus (868 MHz Only)
- CEL Application Programming Interface (API)
- Silicon Labs EZMac

The MeshConnect Sub-G Development Kits provide an excellent platform to evaluate the hardware as well as develop application code for the various software solutions supported. It also provides a set of demo applications to conduct several tests. Below is the list of the demo software features:

SOFTWARE/FIRMWARE (Continued)

- Self Healing (Orphan handling)
- Point-to-Point network formation
- Point-to-Multipoint (Star) network formation
- Mesh network formation*
- ACK
- Wakeup Modes (Si100X)
- Frequency Hopping
- Unicast Addressing using 16-bit device IDs
- Broadcast Addressing
- Packet Forwarding (Master node only)
- Forwarding Table Aging (Master node only)
- Listen Before Talk (LBT)
- RSSI
- Packet Filtering
- Pairing/Joining
- Network Synchronization
- Command line interface for debug/testing/configuration
- Push buttons for Range or PER packet test on an Eval board
- Save configuration to flash
- Save configuration to external flash
- Low Battery detection

* Under development.

MODULE DIMENSIONS

MeshConnect™ Sub-G Module with U.FL Connector for external antenna
MeshConnect™ Sub-G Module with RPSMA Connector for external Antenna

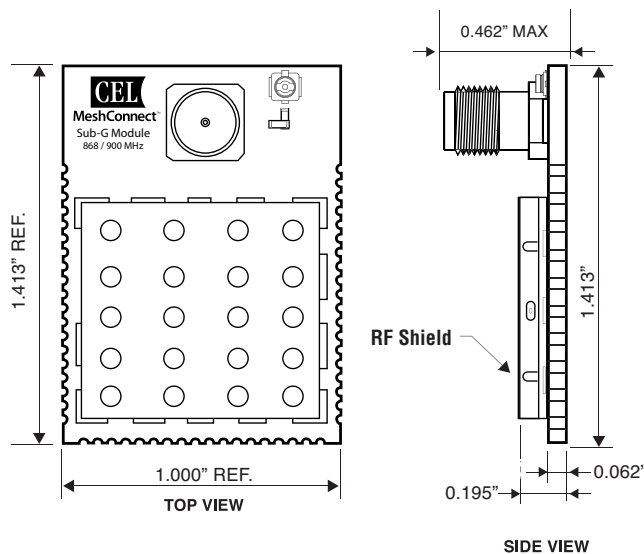

For layout recommendation for optimum antenna performance, refer to Antenna section in this document.

MODULE LAND FOOTPRINT

Note: Unless otherwise specified. Dimensions are in Inches [mm].

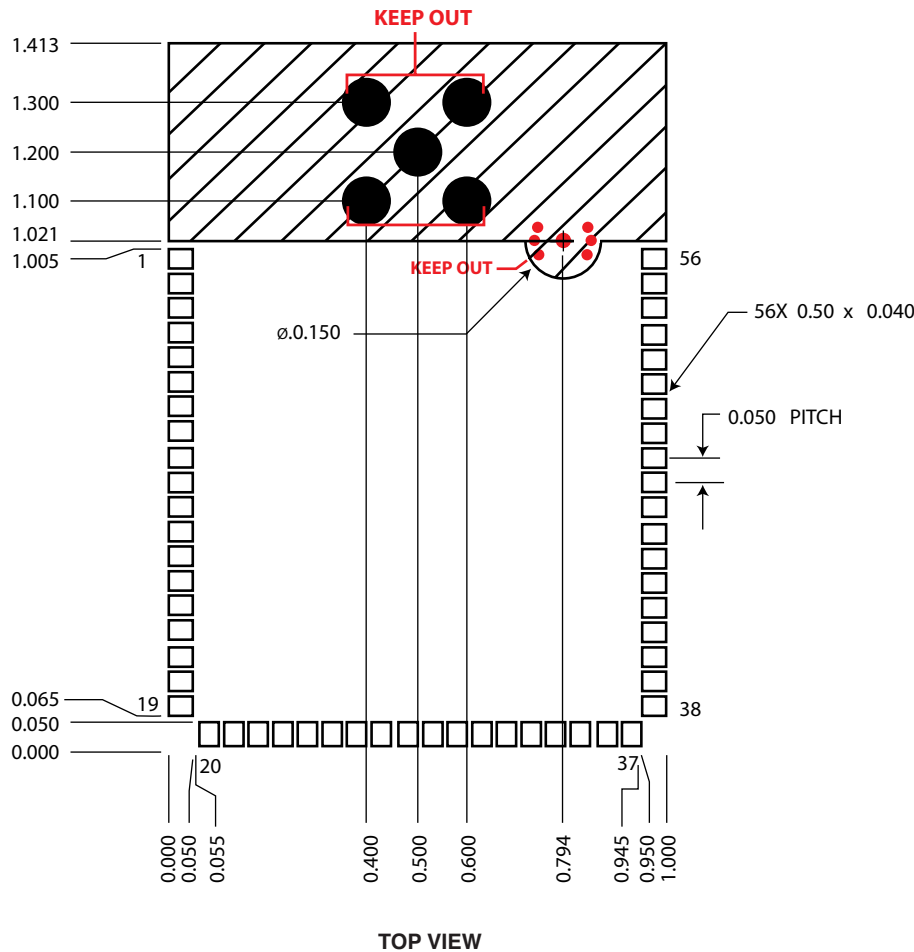

EVALUATION BOARD

CEL provides an Evaluation board to allow easy testing of the Module. The Evaluation board provides power via:

- AA cell batteries
- USB
- AC Adapter regulated down to 3.3VDC
- External Lab Power Supply (A jumper is also provided for the purposes of monitoring the DC current of the module under various modes of operation).

Also included on the evaluation board are four momentary push button switches and four LEDs, a piezo buzzer, a potentiometer, and a SPI memory IC. The peripherals are connected to GPIO of the module (see notes in Pin definitions) through slide switches. If the user would want to connect user specific circuits to the GPIO, slide switches can be used to disconnect the evaluation board peripherals.

The purpose of the evaluation board is to demonstrate simple applications of using GPIO, communicating with the device and also allow flexibility for user specific needs.

PROCESSING

Recommended Reflow Profile

| Parameters Values | |
|---------------------------------------|-------------|
| Ramp up rate (from Tsoakmax to Tpeak) | 3°/sec max |
| Minimum Soak Temperature | 150°C |
| Maximum Soak Temperature | 200°C |
| Soak Time | 60-120 sec |
| TLiquidus | 217°C |
| Time above TL | 60-150 sec |
| Tpeak | 250°C |
| Time within 5° of Tpeak | 20-30 sec |
| Time from 25° to Tpeak | 8 min max |
| Ramp down rate | 6°C/sec max |

Pb-Free Solder Paste

Use of “No Clean” soldering paste is strongly recommended, as it does not require cleaning after the soldering process.

Note: The quality of solder joints on the castellations (‘half vias’) where they contact the host board should meet the appropriate IPC Specification. See the latest **IPC-A-610** Acceptability of Electronic Assemblies, Castellated Terminations section.

Cleaning

In general, cleaning the populated modules is strongly discouraged. Residuals under the module cannot be easily removed with any cleaning process.

- Cleaning with water can lead to capillary effects where water is absorbed into the gap between the host board and the module. The combination of soldering flux residuals and encapsulated water could lead to short circuits between neighboring pads. Water could also damage any stickers or labels.
- Cleaning with alcohol or a similar organic solvent will likely flood soldering flux residuals into the two housings, which is not accessible for post-washing inspection. The solvent could also damage any stickers or labels.
- Ultrasonic cleaning could damage the module permanently.

The best approach is to consider using a “no clean” solder paste and eliminate the post-soldering cleaning step.

Optical Inspection

After soldering the Module to the host board, consider optical inspection to check the following:

- Proper alignment and centering of the module over the pads.
- Proper solder joints on all pads.
- Excessive solder or contacts to neighboring pads, or vias.

Repeating Reflow Soldering

Only a single reflow soldering process is encouraged for host boards.

Wave Soldering

If a wave soldering process is required on the host boards due to the presence of leaded components, only a single wave soldering process is encouraged.

PROCESSING *(Continued)*

Hand Soldering

Hand soldering is possible. When using a soldering iron, follow IPC recommendations (reference document IPC-7711)

Rework

The MeshConnect Module can be unsoldered from the host board. Use of a hot air rework tool should be programmable and the solder joint and module should not exceed the maximum peak reflow temperature of 250 °C.

Caution If temperature ramps exceed the reflow temperature profile, module and component damage may occur due to thermal shock. Avoid overheating.

Warning Never attempt a rework on the module itself, e.g. replacing individual components. Such actions will terminate warranty coverage.

Additional Grounding

Attempts to improve module or system grounding by soldering braids, wires, or cables onto the module RF shield cover is done at the customer's own risk. The numerous ground pins at the module perimeter should be sufficient for optimum immunity to external RF interference.

AGENCY CERTIFICATIONS (PENDING)

FCC Compliance Statement (Part 15.19) Section 7.15 of RSS-GEN

This device complies with Part 15 of the FCC Rules. Operation is subject to the following two conditions:

1. This device may not cause harmful interference.
2. This device must accept any interference received, including interference that may cause undesired operation.

Warning (Part 15.21)

Changes or modifications not expressly approved by CEL could void the user's authority to operate the equipment.

20 cm Separation Distance

To comply with FCC/IC RF exposure limits for general population / uncontrolled exposure, the antenna(s) used for this transmitter must be installed to provide a separation distance of at least 20 cm from all persons and must not be co-located or operating in conjunction with any other antenna or transmitter.

OEM Responsibility to the FCC Rules and Regulations

The MeshConnect Module has been certified per FCC Part 15 rules for integration into products without further testing or certification. To fulfill the FCC certification requirements, the OEM of the MeshConnect Module must ensure that the information provided on the MeshConnect Label is placed on the outside of the final product. The MeshConnect Module is labeled with its own FCC ID Number. If the FCC ID is not visible when the module is installed inside another device, then the outside of the device into which the module is installed must also display a label referring to the enclosed module. This exterior label can use wording such as the following: "Contains Transmitter Module FCC ID: TBD" or "Contains FCC ID: TBD"

The OEM of the MeshConnect Module must only use the approved antenna, that has been certified with this module. The OEM of the MeshConnect Module must test their final product configuration to comply with Unintentional Radiator Limits before declaring FCC compliance per Part 15 of the FCC rules.

AGENCY CERTIFICATIONS *(Continued)*

IC Certification — Industry Canada Statement

The term "IC" before the certification / registration number only signifies that the Industry Canada technical specifications were met.

This device complies with Industry Canada license-exempt RSS standard(s). Operation is subject to the following two conditions: (1) this device may not cause interference, and (2) this device must accept any interference, including interference that may cause undesired operation of the device.

Le présent appareil est conforme aux CNR d'Industrie Canada applicables aux appareils radio exempts de licence. L'exploitation est autorisée aux deux conditions suivantes : (1) l'appareil ne doit pas produire de brouillage, et (2) l'utilisateur de l'appareil doit accepter tout brouillage radioélectrique subi, même si le brouillage est susceptible d'en compromettre le fonctionnement

Section 14 of RSS-210

The installer of this radio equipment must ensure that the antenna is located or pointed such that it does not emit RF field in excess of Health Canada limits for the general population. Consult Safety Code 6, obtainable from Health Canada's website: <http://www.hc-sc.gc.ca/ewh-semt/pubs/radiation/99ehd-dhm237/index-eng.php>

CE Certification — Europe ZICM0868P0 (PENDING)

The MeshConnect 868MHz RF modules will be tested and certified for the European Union.

OEM Responsibility to the European Union Compliance Rules

If the MeshConnect module is to be incorporated into a product, the OEM must verify compliance of the final product to the European Harmonized EMC and Low-Voltage / Safety Standards. A Declaration of Conformity must be issued for each of these standards and kept on file as described in Annex II of the R&TTE Directive.

The manufacturer must maintain the user's guide and adhere to the settings described in the manual for maintaining European Union Compliance. If any of the specifications are exceeded in the final product, the OEM is required to make a submission to the notified body for compliance testing.

OEM Labeling Requirements

The `CE' mark must be placed on the OEM product in a visible location.

The CE mark shall consist of the initials "CE" with the following form:

- If the CE marking is reduced or enlarged, the proportions given in the above graduated drawing must be adhered to.
- The CE mark must be a minimum of 5mm in height
- The CE marking must be affixed visibly, legibly, and indelibly. Since the 868 MHz band is not harmonized by a few countries throughout Europe, the Restriction sign must be placed to the right of the "CE" marking as shown in the picture



SHIPMENT, HANDLING, AND STORAGE

Shipment

The MeshConnect Modules are delivered in trays of 28.

Handling

The MeshConnect Modules are designed and packaged to be processed in an automated assembly line.

Warning The MeshConnect Modules contain highly sensitive electronic circuitry. Handling without proper ESD protection may destroy or damage the module permanently.

Warning The MeshConnect Modules are moisture-sensitive devices. Appropriate handling instructions and precautions are summarized in J-STD-033. Read carefully to prevent permanent damage due to moisture intake.

Moisture Sensitivity Level (MSL)

MSL 3, per J-STD-033

Storage

Storage/shelf life in sealed bags is 12 months at <40°C and <90% relative humidity.

QUALITY

CEL modules offer the highest quality at competitive prices. Our modules are manufactured in compliance with the IPC-A-610 specification, Class II. Our modules go through JESD22 qualification processes which includes high temperature operating life tests, mechanical shock, temperature cycling, humidity and reflow testing. CEL conducts 100% RF and DC factory testing on all production parts and also conducts sample testing on all device lots.

CEL's builds the quality into our products giving our customers the confidence when integrating our products into their systems.

REFERENCES & REVISION HISTORY

| Previous Versions | Changes to Current Version | Page(s) |
|---|---------------------------------|---------|
| 0008-00-07-00-000 (Issue ES) April 5, 2011 | Initial preliminary datasheet. | N/A |
| 0008-00-07-00-000 (Issue ES) June 1, 2011 | IC Certification. | N/A |
| 0008-00-07-00-000 (Issue ES) June 10, 2011 | Revised Development Kit content | 3 |

Disclaimer

- The information in this document is current as of the published date. The information is subject to change without notice. For actual design-in, refer to the latest publications of CEL data sheets or data books, etc., for the most up-to-date specifications of CEL products. Not all products and/or types are available in every country. Please check with an CEL sales representative for availability and additional information.
- No part of this document may be copied or reproduced in any form or by any means without the prior written consent of CEL. CEL assumes no responsibility for any errors that may appear in this document.
- CEL does not assume any liability for infringement of patents, copyrights or other intellectual property rights of third parties by or arising from the use of CEL products listed in this document or any other liability arising from the use of such products. No license, express, implied or otherwise, is granted under any patents, copyrights or other intellectual property rights of CEL or others.
- Descriptions of circuits, software and other related information in this document are provided for illustrative purposes in semiconductor product operation and application examples. The incorporation of these circuits, software and information in the design of a customer's equipment shall be done under the full responsibility of the customer. CEL assumes no responsibility for any losses incurred by customers or third parties arising from the use of these circuits, software and information.
- While CEL endeavors to enhance the quality, reliability and safety of CEL products, customers agree and acknowledge that the possibility of defects thereof cannot be eliminated entirely. To minimize risks of damage to property or injury (including death) to persons arising from defects in CEL products, customers must incorporate sufficient safety measures in their design, such as redundancy, fire-containment and anti-failure features.