

<h1>NAIS</h1>	ULTRA-MINIATURE SWITCHES WITH HIGH PRECISION	<h1>FJ (AH1) SWITCHES</h1>
---------------	---	----------------------------

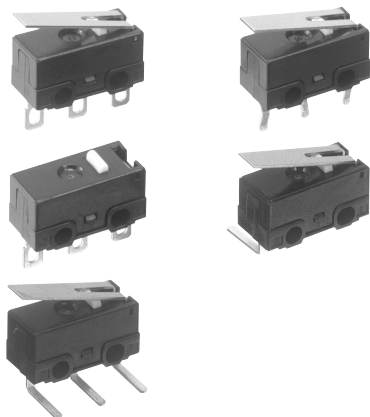

FEATURES

- Integrally molded terminal block—prevents soldering flux from entering into housing
- Compact size —minimizes size of equipment
- Flat terminal shape—makes soldering works easy
- Low-level circuit type available
- Self-standing PC board terminal type available

TYPICAL APPLICATIONS

- Mouse
- Charger unit for mobile phone
- Detection of key position for automobiles

ORDERING INFORMATION

Ex. AH 1 4 8 0 61

Product Name	Terminal	Operating force by pin plunger (max.)	Actuator	Contact	Contact arrangement
FJ	4: 2.0 mm Self-standing PC board terminal with stand off 6: 2.0 mm solder terminal with stand off 7: 2.0 mm PC board right angle terminal 8: 2.0 mm PC board left angle terminal	6: 1.47 N {150 gf} with stand off 8: 0.74 N {75 gf} with stand off	0: Pin plunger 2: Hinge lever 4: Simulated roller lever	Nil: Silver alloy 61: Gold-clad	Nil: SPDT A: SPST-NO

Remark: 2.0 mm PC board terminal straight type is available. For details, please consult us.

PRODUCT TYPES

The color of:

Color	Body	Cap	Plunger
Standard	Black	Black	White
Low-level circuit	Black	Black	Red

1. Self-standing PC board terminal

Actuators	Operating force, Max.	Standard (Silver alloy contact)		Low-level circuit (Gold-clad contact)
		SPDT	SPST-NO	SPDT
Pin plunger	0.74 N {75 gf}	AH1480	AH1480A	AH148061
	1.47 N {150gf}	AH1460	AH1460A	AH146061
Hinge lever	0.25 N {25gf}	AH1482	AH1482A	AH148261
	0.49 N {50gf}	AH1462	AH1462A	AH146261
Simulated roller lever	0.26 N {27gf}	AH1484	AH1484A	AH148461
	0.54 N {55gf}	AH1464	AH1464A	AH146461

2. Solder terminal

Actuators	Operating force, Max.	Standard (Silver alloy contact)		Low-level circuit (Gold-clad contact)
		SPDT	SPST-NO	SPDT
Pin plunger	0.74 N {75 gf}	AH1680	AH1680	AH168061
	1.47 N {150gf}	AH1660	AH1660	AH166061
Hinge lever	0.25 N {25gf}	AH1682	AH1682	AH168261
	0.49 N {50gf}	AH1662	AH1662	AH166261
Simulated roller lever	0.26 N {27gf}	AH1684	AH1684	AH168461
	0.54 N {55gf}	AH1664	AH1664	AH166461

3. PC board terminal right angle

Actuators	Operating force, Max.	Standard (Silver alloy contact)	Low-level circuit (Gold-clad contact)
		SPDT	SPDT
Pin plunger	0.74 N {75 gf}	AH1780	AH178061
Pin plunger	1.47 N {150gf}	AH1760	AH176061
Hinge lever	0.25 N {25gf}	AH1782	AH178261
Hinge lever	0.49 N {50gf}	AH1762	AH176261
Simulated roller lever	0.26 N {27gf}	AH1784	AH178461
Simulated roller lever	0.54 N {55gf}	AH1764	AH176461

4. PC board terminal left angle

Actuators	Operating force, Max.	Standard (Silver alloy contact)	Low-level circuit (Gold-clad contact)
		SPDT	SPDT
Pin plunger	0.74 N {75 gf}	AH1880	AH188061
	1.47 N {150gf}	AH1860	AH186061
Hinge lever	0.25 N {25gf}	AH1882	AH188261
	0.49 N {50gf}	AH1862	AH186261
Simulated roller lever	0.26 N {27gf}	AH1884	AH188461
	0.54 N {55gf}	AH1864	AH186461

Remarks: 1. The appearance of right and left angle types are as below.

Right angle



Left angle



- 2. When ordering UL/CSA approved types, please attach suffix "9" to the part number.
- 3. Standard packing: 50 pcs./tube.
- 4. Please consult us for the delivery schedule of PC board terminal SPST-NO type.

APPLICABLE CURRENT RANGE

Contact	Applicable current range				Max. operating force for operation (at pin plunger)	
	1 mA	0.1 A	1 A	3 A	0.74 N {75 gf}	1.47 N {150 gf}
Standard type (Silver alloy)			■		●	
			■			●
Low level circuit type (Gold-clad)	■				●	
	■					●

SPECIFICATIONS

1. Contact rating (resistive load)

		Standard rating	Low-level rating
Standard type	O.F. 75g 2.65oz	1A 125V AC, 1A 30V DC	—
	O.F. 150g 5.29oz	3A 125V AC, 2A 30V DC	—
Low-level circuit type		0.1A 125V AC, 0.1A 30V DC	5mA 6V DC, 2mA 12V DC, 1mA 24V DC

2. Characteristics

Contact arrangement	Standard type	Low-level circuit type
Expected life (Min. operations) Electrical (at rated load, 20 cpm) (O.T.: Max.)	3 × 10 ⁴	10 ⁵
Expected life (Min. operations) Mechanical (at 60 cpm) (O.T.: Specified value)	O.F. 0.74 N {75 gf}: 10 ⁶ O.F. 1.47 N {150 gf}: 5 × 10 ⁵	
Dielectric strength (initial) Between terminals Between terminals and other exposed parts Between terminals and ground	600 Vrms for 1 min. 1,500 Vrms for 1 min. 1,500 Vrms for 1 min.	
Insulation resistance (Min. at 500V DC)	100 MΩ	
Initial contact resistance	Max. 30 mΩ (by voltage drop, 1A 6 to 8V DC)	Max. 100 mΩ (by voltage drop, 0.1A 6 to 8V DC)
Allowable operating speed (No load)	1 to 500 mm/sec.	
Max. operating cycle rate (No load)	120 cpm	
Ambient temperature	-25 to +85°C -13 to +185°F (Not freezing below 0°C 32°F)	
Ambient humidity	Max. 85% R.H.	
Shock resistance (Pin plunger type)	Min. 294 m/s ² {30G} (Contact opening: Max. 1 msec.)	
Vibration resistance (Pin plunger type)	10 to 55 Hz at single amplitude of 0.75mm (Contact opening: Max. 1 msec.)	

3. Operating characteristics

Type of actuator	Operating force, Max.		Release force, Min.		Pretravel, Max. mm inch	Movement differential, Max. mm inch	Overtravel, Min. mm inch	Operating position mm inch	
	5th digit of Part No.		5th digit of Part No.				5th digit of Part No.	5th digit of Part No.	
	6	8	6	8			6, 8	6,8	
							Distance from stand off	Distance from mounting hole	
Pin plunger	1.47 N {150 gf}	0.74 N {75 gf}	0.20 N {20 gf}	0.098 N {10 gf}	0.5 .020	0.12 .005	0.25 .010	7±0.3 .276±.012	5.5±0.2 .217±.008
Hinge lever	0.49 N {50 gf}	0.25 N {25 gf}	0.049 N {5 gf}	0.025 N {2.5 gf}	2.1 .083	0.5 .020	0.55 .022	8.3±1.2 .327±.047	6.8±1.0 .268±.039
Simulated roller lever	0.54 N {55 gf}	0.26 N {27 gf}	0.039 N {4 gf}	0.020 N {2 gf}	2.1 .083	0.5 .020	0.5 .020	11.0±1.2 .433±.047	9.5±1.0 .374±.039

DATA

Gold-clad type

Range of low-level current voltage

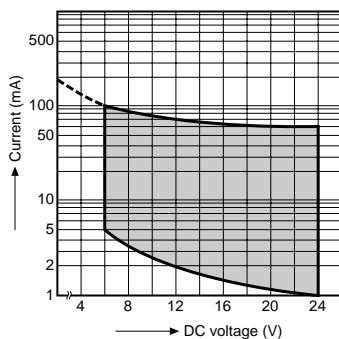

DIMENSIONS

mm inch

1. Self-standing PC board terminal (Standard type)

Pin plunger

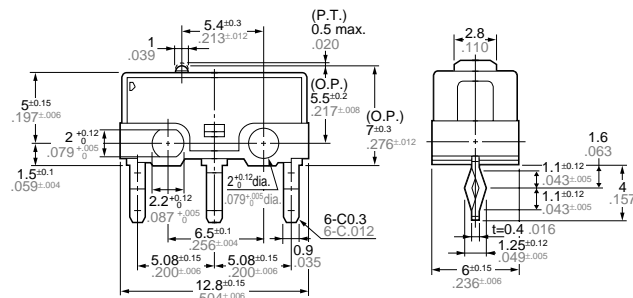

PC board pattern

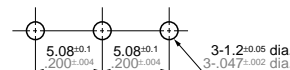

Pretravel, Max. mm inch		0.5 .020
Movement differential, Max. mm inch		0.12 .005
Overtravel, Min. mm inch		0.25 .010
Operating position	Distance from mounting hole, mm inch	5.5±0.2 .217±.008
	Distance from standoff, mm inch	7±0.3 .276±.012

Hinge lever

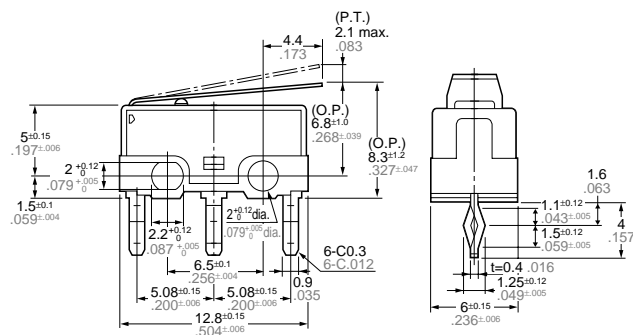

PC board pattern



Pretravel, Max. mm inch		2.1 .083
Movement differential, Max. mm inch		0.5 .020
Overtravel, Min. mm inch		0.5 .020
Operating position	Distance from mounting hole, mm inch	9.5±1.0 .374±.039
	Distance from standoff, mm inch	11.0±1.2 .433±.047

Simulated roller lever

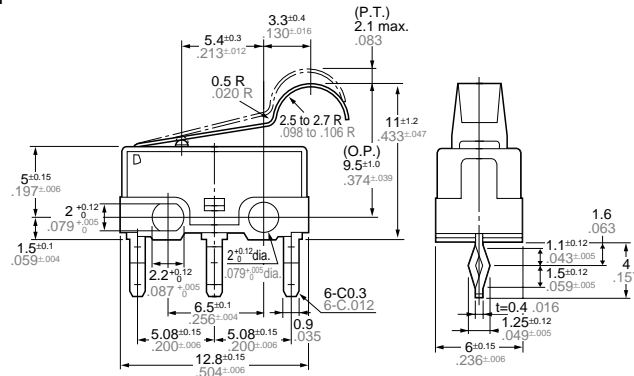

PC board pattern

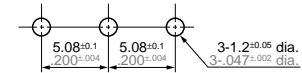

Pretravel, Max. mm inch	2.1 .083	
Movement differential, Max. mm inch	0.5 .020	
Overtravel, Min. mm inch	0.5 .020	
Operating position	Distance from mounting hole, mm inch	9.5±1.0 .374±.039
	Distance from standoff, mm inch	11.0±1.2 .433±.047

2. Solder terminal

Pin plunger

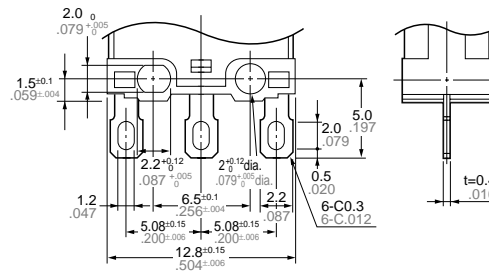

Remark: As for other actuator types, dimensions are the same as those of corresponding standard PC board terminal type.

3. PC board terminal (Right/Left angle type)

Pin plunger

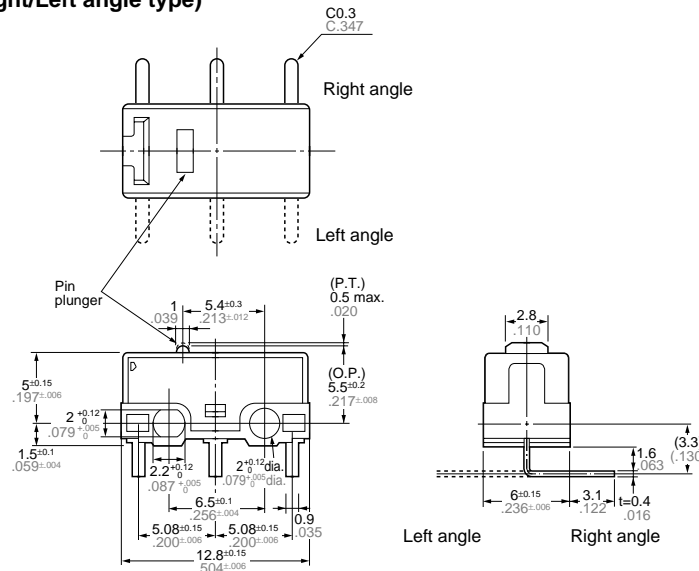
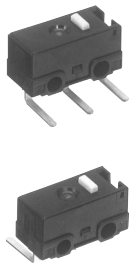

Recommended PC board pattern (top view)

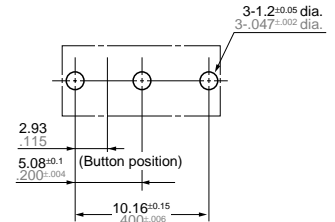

Remark: As for other actuator types, dimensions are the same as those of corresponding standard PC board terminal type.

NOTES

1. Fixing

- 1) Use 2mm mounting screws to attach switches with Max. 1.0 kg-cm torque. Use of screw washers or adhesive lock is recommended.
- 2) When the operation object is in the free position, force should not be applied directly to the actuator or to the pin plunger. Also force should be applied to the pin plunger from vertical direction to the switch.

- 3) In setting the movement after operation, the over-travel should be set from 70% to 100%. Setting the movement less than 70% may cause degrading the electrical mechanical performance.

2. When specifying FJ switches, allow ±20% to the listed operating and release forces.

3. Soldering operation

- 1) For manual soldering: 18 W soldering iron, soldering completed within 3 sec-

- onds; do not apply force to the terminals.
- 2) For automatic soldering tank: 260°C +500°F immersion, completed within 5 seconds, 350°C +662°F immersion, completed within 3 seconds.

4. When switching low-level circuits, FJ low-level circuit type is recommended.