

LM5050-1EVAL Evaluation Board

National Semiconductor
Application Note 2087
Donald P. Jones
April 26, 2011



Introduction

The LM5050-1 evaluation board is designed to demonstrate the capabilities of the LM5050-1 OR-ing Diode Controller. One high side N-channel power MOSFET is used. The LM5050-1 evaluation board schematic is shown in [Figure 5](#). The evaluation board is designed to highlight applications with a small solution size. For more information about LM5050-1 functional and electrical characteristics, refer to the LM5050-1 datasheet.

Operating Range

- Minimum Input Voltage, 6V
- Maximum Input Voltage, 50V
- Output Current Range: 0A to 15A
- Ambient Temperature Range 0°C to 50°C
- Board Size 1.50 inches x 2.25 inches

To aid in the demonstration and evaluation of high-side OR-ing diode controller solution based on the LM5050-1.

The load current capability is limited at 15A by the ratings of the terminals and the PCB copper area and weight. The PCB layout has not been tested for currents above 15A, so this should only be done with some degree of caution.

The maximum input voltage is limited by the breakdown voltage rating of both D1 and D2.

Typical evaluation board performance and characteristics curves are shown in [Figure 1](#) through [Figure 2](#). The PCB layout is shown in [Figure 7](#) and [Figure 8](#). Test points are provided for optional control and signal monitoring.

Evaluation Board Start-Up

Before applying power to the LM5050-1 evaluation board, all external connections should be verified. The external power supply must be turned off and connected with proper polarity to the VS, VIN, VOUT, and GND terminals. Under basic evaluation conditions the Off test point is left open.

The evaluation board will be in the normal operating mode when power is applied. The Off terminal is used only when there is a desire to disable normal operation.

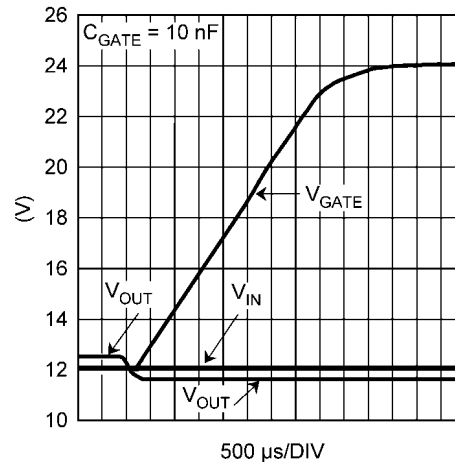

30133412

FIGURE 1. Forward Waveforms

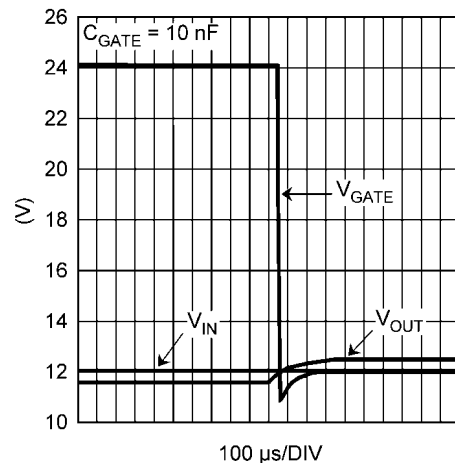

30133413

FIGURE 2. Reverse Waveforms

Inductive Kick-Back Protection

Diode D1 and capacitor C1 serve as inductive kick-back protection to limit negative transient voltage spikes generated on the input when the input supply voltage is abruptly taken to zero volts.

Diode D2 and capacitor C2 serve as inductive kick-back protection to limit positive transient voltage spikes generated on the output when the input supply voltage is abruptly taken to zero volts.

Off Test Point

The Off test point provided on the LM5050-1 evaluation board is used to control the LM5050-1 operation. The Off test point is connected directly to the LM5050-1 OFF pin. See the LM5050-1 datasheet for more details.

To enable the LM5050-1 apply a voltage less than 0.8V to the Off test point, connect the Off test point to GND, or leave the Off test point open (default). If the Off test point is left open, the LM5050-1 OFF pin internal pull-down will ensure that the LM5050-1 becomes operational.

To disable the LM5050-1 apply a voltage greater than 2.0V to the Off test point.

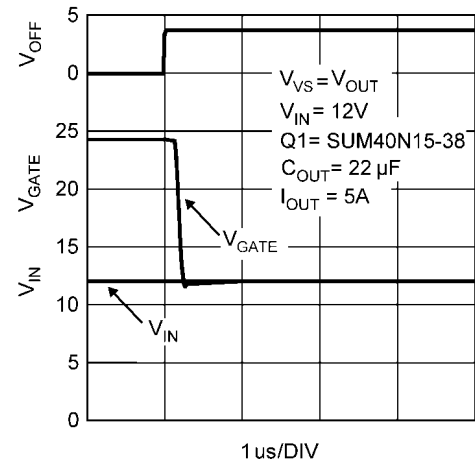

30133416

FIGURE 3. OFF pin vs GATE

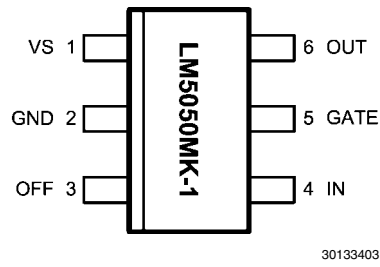

FIGURE 4. Connection Diagram

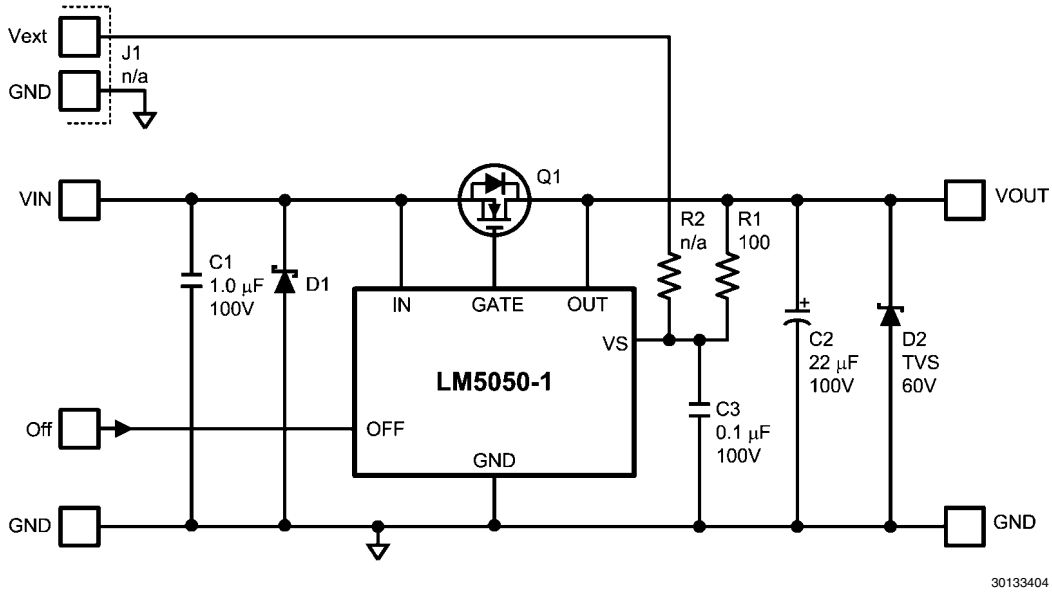

FIGURE 5. Schematic Diagram

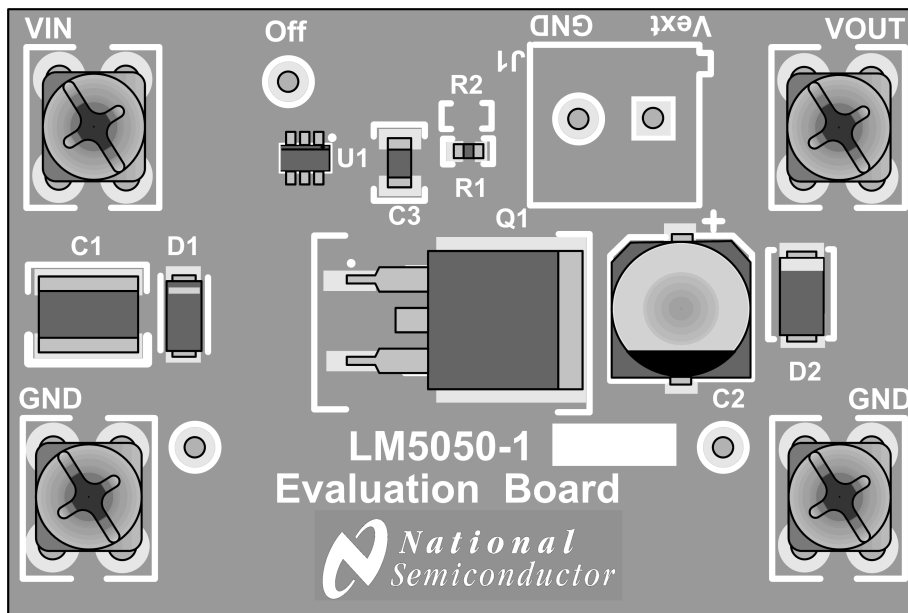
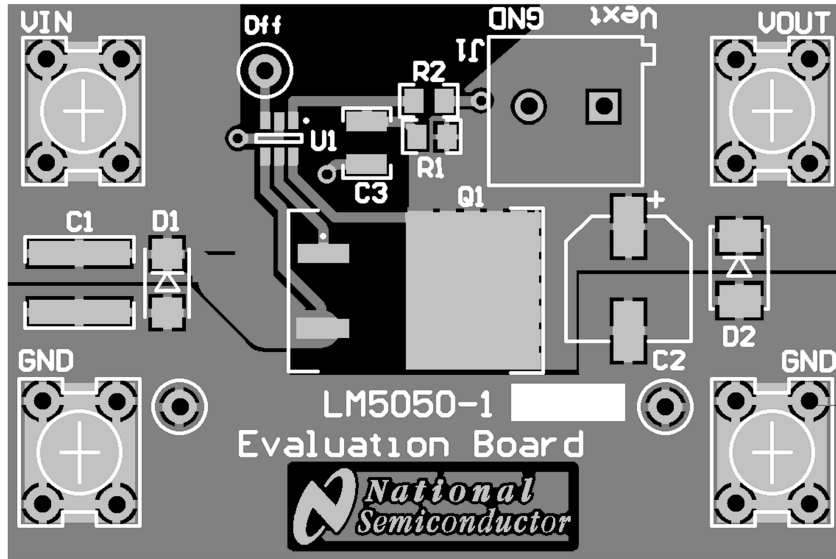

FIGURE 6. Component Placement



30133405

FIGURE 7. Evaluation Board, Top Side (Component)



30133406

FIGURE 8. Evaluation Board, Bottom Side

Bill of Materials

ID	Description	Manufacturer	Mfgr Part Number
U1	IC; Ideal OR-ing Diode Controller	National Semiconductor Corporation	LM5050MK-1
C1	Capacitor: MLCC; 1.0 μ F; \pm 10%; 100V; X7R; 1825	Vishay/Vitramon	VJ1825Y105KBBAT4X
C2	Capacitor: 22 μ F; \pm 20%; 100V; Aluminum Electrolytic; SMT	Panasonic/ECG	EEE-HA2A220P
C3	Capacitor: 0.1 μ F; MLCC; \pm 10%; 100V; X7R; 1210	Murata Electronics North America	GRM32NR72A104KA01L
D1	Diode: Schottky Barrier Rectifier; 1A; 60V; SMA	ON Semiconductor	SS16T3G
		Micro Commercial Components	SS16-TP
D2	Diode: TVS; Unidirectional; 600W; 60V; SMB	Diodes Inc	SMBJ60A-13-F
J1	Not Installed	-	-
Q1	MOSFET: N-Channel; 100V; 40A; 0.025 Ω ; D ² PAK	Vishay/Siliconix	SUM40N10-30-E3
R1	Resistor: 100 Ω ; 0.10W; \pm 1%; 100ppm; Thick Film; 0603	Vishay/Dale	CRCW0603100RFKEA
		ROHM Semiconductor	MCR03EZPFX1000
R2	Not Installed	-	-
VIN	Terminal: 6-32 Screw; Vertical; Snap-In PCB Mount; 15A	Keystone Electronics	7693
VOUT			
GND			
GND			
Off	Test Point Terminal: 0.040in Dia Mtg Hole; White	Keystone Electronics	5012
GND			
GND			

Notes

For more National Semiconductor product information and proven design tools, visit the following Web sites at:
www.national.com

Products		Design Support	
Amplifiers	www.national.com/amplifiers	WEBENCH® Tools	www.national.com/webench
Audio	www.national.com/audio	App Notes	www.national.com/appnotes
Clock and Timing	www.national.com/timing	Reference Designs	www.national.com/refdesigns
Data Converters	www.national.com/adc	Samples	www.national.com/samples
Interface	www.national.com/interface	Eval Boards	www.national.com/evalboards
LVDS	www.national.com/lvds	Packaging	www.national.com/packaging
Power Management	www.national.com/power	Green Compliance	www.national.com/quality/green
Switching Regulators	www.national.com/switchers	Distributors	www.national.com/contacts
LDOs	www.national.com/lido	Quality and Reliability	www.national.com/quality
LED Lighting	www.national.com/led	Feedback/Support	www.national.com/feedback
Voltage References	www.national.com/vref	Design Made Easy	www.national.com/easy
PowerWise® Solutions	www.national.com/powerwise	Applications & Markets	www.national.com/solutions
Serial Digital Interface (SDI)	www.national.com/sdi	Mil/Aero	www.national.com/milaero
Temperature Sensors	www.national.com/tempensors	SolarMagic™	www.national.com/solarmagic
PLL/VCO	www.national.com/wireless	PowerWise® Design University	www.national.com/training

THE CONTENTS OF THIS DOCUMENT ARE PROVIDED IN CONNECTION WITH NATIONAL SEMICONDUCTOR CORPORATION ("NATIONAL") PRODUCTS. NATIONAL MAKES NO REPRESENTATIONS OR WARRANTIES WITH RESPECT TO THE ACCURACY OR COMPLETENESS OF THE CONTENTS OF THIS PUBLICATION AND RESERVES THE RIGHT TO MAKE CHANGES TO SPECIFICATIONS AND PRODUCT DESCRIPTIONS AT ANY TIME WITHOUT NOTICE. NO LICENSE, WHETHER EXPRESS, IMPLIED, ARISING BY ESTOPPEL OR OTHERWISE, TO ANY INTELLECTUAL PROPERTY RIGHTS IS GRANTED BY THIS DOCUMENT.

TESTING AND OTHER QUALITY CONTROLS ARE USED TO THE EXTENT NATIONAL DEEMS NECESSARY TO SUPPORT NATIONAL'S PRODUCT WARRANTY. EXCEPT WHERE MANDATED BY GOVERNMENT REQUIREMENTS, TESTING OF ALL PARAMETERS OF EACH PRODUCT IS NOT NECESSARILY PERFORMED. NATIONAL ASSUMES NO LIABILITY FOR APPLICATIONS ASSISTANCE OR BUYER PRODUCT DESIGN. BUYERS ARE RESPONSIBLE FOR THEIR PRODUCTS AND APPLICATIONS USING NATIONAL COMPONENTS. PRIOR TO USING OR DISTRIBUTING ANY PRODUCTS THAT INCLUDE NATIONAL COMPONENTS, BUYERS SHOULD PROVIDE ADEQUATE DESIGN, TESTING AND OPERATING SAFEGUARDS.

EXCEPT AS PROVIDED IN NATIONAL'S TERMS AND CONDITIONS OF SALE FOR SUCH PRODUCTS, NATIONAL ASSUMES NO LIABILITY WHATSOEVER, AND NATIONAL DISCLAIMS ANY EXPRESS OR IMPLIED WARRANTY RELATING TO THE SALE AND/OR USE OF NATIONAL PRODUCTS INCLUDING LIABILITY OR WARRANTIES RELATING TO FITNESS FOR A PARTICULAR PURPOSE, MERCHANTABILITY, OR INFRINGEMENT OF ANY PATENT, COPYRIGHT OR OTHER INTELLECTUAL PROPERTY RIGHT.

LIFE SUPPORT POLICY

NATIONAL'S PRODUCTS ARE NOT AUTHORIZED FOR USE AS CRITICAL COMPONENTS IN LIFE SUPPORT DEVICES OR SYSTEMS WITHOUT THE EXPRESS PRIOR WRITTEN APPROVAL OF THE CHIEF EXECUTIVE OFFICER AND GENERAL COUNSEL OF NATIONAL SEMICONDUCTOR CORPORATION. As used herein:

Life support devices or systems are devices which (a) are intended for surgical implant into the body, or (b) support or sustain life and whose failure to perform when properly used in accordance with instructions for use provided in the labeling can be reasonably expected to result in a significant injury to the user. A critical component is any component in a life support device or system whose failure to perform can be reasonably expected to cause the failure of the life support device or system or to affect its safety or effectiveness.

National Semiconductor and the National Semiconductor logo are registered trademarks of National Semiconductor Corporation. All other brand or product names may be trademarks or registered trademarks of their respective holders.

Copyright© 2011 National Semiconductor Corporation

For the most current product information visit us at www.national.com



National Semiconductor Americas Technical Support Center
 Email: support@nsc.com
 Tel: 1-800-272-9959

National Semiconductor Europe Technical Support Center
 Email: europe.support@nsc.com

National Semiconductor Asia Pacific Technical Support Center
 Email: ap.support@nsc.com

National Semiconductor Japan Technical Support Center
 Email: jpn.feedback@nsc.com