

Cree® XLamp® XM-L EasyWhite™ LEDs

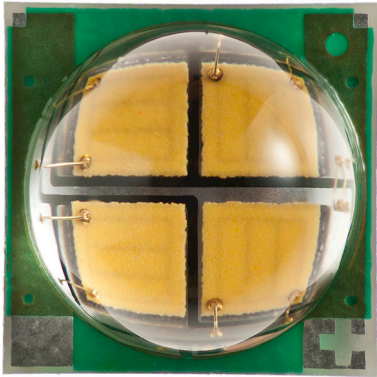

PRODUCT DESCRIPTION

The XLamp XM-L EasyWhite LED eliminates chromaticity binning, and enables luminaire and bulb manufacturers to deliver the consistent color and high efficacy light output of a multi-die LED in the compact XM-L footprint. XLamp XM-L EasyWhite LEDs can reduce LED-to-LED color variation to within a 2-step MacAdam ellipse, 94% smaller than the total area of the corresponding ANSI C78.377 color region.

The XLamp XM-L EasyWhite LED is the perfect choice for lighting applications where moderate to high luminous flux output is required from a single, small point source. Example applications include: LED retrofit bulbs, commercial/retail display spotlights, and other indoor general illumination applications.

FEATURES

- Available in 4-step and 2-step EasyWhite bins at 2,700K, 3,000K, 3,500K, 4,000K CCT.
- Wide range of operating current - up to 2A @ 6V
- 85° C binning and characterization
- Available in 6V and 12V versions
- Low thermal resistance: 2.5° C/W
- Wide viewing angle: 115°
- Wide variety of CRI choices: standard CRI as well as 80, 85, 90 minimum CRI.
- Electrically neutral thermal path
- Unlimited floor life at ≤ 30°C/85% RH
- Reflow solderable - JEDEC J-STD-020C

TABLE OF CONTENTS

Product Characteristics.....	2
Flux Characteristics, Standard Order Codes and Bins, 6 Volt XM-L EZW	2
Flux Characteristics, Standard Order Codes and Bins, 12 Volt XM-L EZW	4
Relative Spectral Power Distribution.....	5
Relative Flux vs. Junction Temperature	6
Electrical Characteristics.....	6
Relative Flux vs. Current	7
Relative Chromaticity vs. Current and Temperature	8
Typical Spatial Distribution.....	9
Thermal Design.....	9
Performance Groups - Brightness (T _j = 85° C).....	10
Performance Groups - Chromaticity (T _j = 85° C).....	10
Cree EasyWhite Color Temperatures Plotted on the 1931 CIE Curve.....	11
Bin and Order Code Formats	12
Reflow Soldering Characteristics .	12
Notes.....	13
Mechanical Dimensions.....	14
Tape and Reel	15
Packaging.....	16

PRODUCT CHARACTERISTICS

Characteristics	Unit	Minimum	Typical	Maximum
Thermal Resistance, junction to solder point	°C/W		2.5	
Viewing Angle (FWHM)	degrees		115	
Temperature coefficient of voltage (6V)	mV/°C		-6.0	
Temperature coefficient of voltage (12V)	mV/°C		-12.0	
ESD Classification (HBM per Mil-Std-883D)			Class 2	
DC Forward Current (6V)	mA		700	2000
DC Forward Current (12V)	mA		350	1000
Reverse Current (6V, 12V)	mA			-0.1
Reverse Voltage (6V, 12V)	V			5
Forward Voltage (@ 700 mA, 85° C, 6V)	V		5.8	7.0
Forward Voltage (@ 350 mA, 85° C, 12V)	V		11.6	14.0
LED junction temperature	°C			150

FLUX CHARACTERISTICS, STANDARD ORDER CODES AND BINS, 6 VOLT XM-L EZW (700 MA, T_J = 85° C)

The following table provides the order codes for 6 Volt XLamp XM-L EZW LEDs.

Color	CCT Range	Base Order Codes Min Luminous Flux @ 700 mA, 85° C		2-Step Order Code		4-Step Order Code	
		Group	Flux (lm)	Chromaticity Region		Chromaticity Region	
Standard CRI EasyWhite	4000K	U4	340	40H	XMLEZW-00-0000-0B00U440H	40F	XMLEZW-00-0000-0B00U440F
		U3	320		XMLEZW-00-0000-0B00U340H		XMLEZW-00-0000-0B00U340F
		U2	300		XMLEZW-00-0000-0B00U240H		XMLEZW-00-0000-0B00U240F
	3500K	U3	320	35H	XMLEZW-00-0000-0B00U335H	35F	XMLEZW-00-0000-0B00U335F
		U2	300		XMLEZW-00-0000-0B00U235H		XMLEZW-00-0000-0B00U235F
		T6	280		XMLEZW-00-0000-0B00T635H		XMLEZW-00-0000-0B00T635F
	3000K	U3	320	30H	XMLEZW-00-0000-0B00U330H	30F	XMLEZW-00-0000-0B00U330F
		U2	300		XMLEZW-00-0000-0B00U230H		XMLEZW-00-0000-0B00U230F
		T6	280		XMLEZW-00-0000-0B00T630H		XMLEZW-00-0000-0B00T630F
		T5	260		XMLEZW-00-0000-0B00T530H		XMLEZW-00-0000-0B00T530F
	2700K	U2	300	27H	XMLEZW-00-0000-0B00U227H	27F	XMLEZW-00-0000-0B00U227F
		T6	280		XMLEZW-00-0000-0B00T627H		XMLEZW-00-0000-0B00T627F
		T5	260		XMLEZW-00-0000-0B00T527H		XMLEZW-00-0000-0B00T527F
		T4	240		XMLEZW-00-0000-0B00T427H		XMLEZW-00-0000-0B00T427F

Color	CCT Range	Base Order Codes Min Luminous Flux @ 700 mA, 85° C		2-Step Order Code		4-Step Order Code	
		Group	Flux (lm)	Chromaticity Region		Chromaticity Region	
80-CRI Minimum EasyWhite	4000K	U4	340	40H	XMLEZW-00-0000-0B0HU440H	40F	XMLEZW-00-0000-0B0HU440F
		U3	320		XMLEZW-00-0000-0B0HU340H		XMLEZW-00-0000-0B0HU340F
		U2	300		XMLEZW-00-0000-0B0HU240H		XMLEZW-00-0000-0B0HU240F
	3500K	U3	320	35H	XMLEZW-00-0000-0B0HU335H	35F	XMLEZW-00-0000-0B0HU335F
		U2	300		XMLEZW-00-0000-0B0HU235H		XMLEZW-00-0000-0B0HU235F
		T6	280		XMLEZW-00-0000-0B0HT635H		XMLEZW-00-0000-0B0HT635F
		T5	260		XMLEZW-00-0000-0B0HT535H		XMLEZW-00-0000-0B0HT535F
	3000K	U3	320	30H	XMLEZW-00-0000-0B0HU330H	30F	XMLEZW-00-0000-0B0HU330F
		U2	300		XMLEZW-00-0000-0B0HU230H		XMLEZW-00-0000-0B0HU230F
		T6	280		XMLEZW-00-0000-0B0HT630H		XMLEZW-00-0000-0B0HT630F
		T5	260		XMLEZW-00-0000-0B0HT530H		XMLEZW-00-0000-0B0HT530F
	2700K	U2	300	27H	XMLEZW-00-0000-0B0HU227H	27F	XMLEZW-00-0000-0B0HU227F
		T6	280		XMLEZW-00-0000-0B0HT627H		XMLEZW-00-0000-0B0HT627F
		T5	260		XMLEZW-00-0000-0B0HT527H		XMLEZW-00-0000-0B0HT527F
		T4	240		XMLEZW-00-0000-0B0HT427H		XMLEZW-00-0000-0B0HT427F
	85-CRI Minimum EasyWhite	3000K	T6	280	30H	XMLEZW-00-0000-0B0PT630H	30F
T5			260	XMLEZW-00-0000-0B0PT530H		XMLEZW-00-0000-0B0PT530F	
T4			240	XMLEZW-00-0000-0B0PT430H		XMLEZW-00-0000-0B0PT430F	
T3			220	XMLEZW-00-0000-0B0PT330H		XMLEZW-00-0000-0B0PT330F	
2700K		T5	260	27H	XMLEZW-00-0000-0B0PT527H	27F	XMLEZW-00-0000-0B0PT527F
		T4	240		XMLEZW-00-0000-0B0PT427H		XMLEZW-00-0000-0B0PT427F
		T3	220		XMLEZW-00-0000-0B0PT327H		XMLEZW-00-0000-0B0PT327F
		T2	200		XMLEZW-00-0000-0B0PT227H		XMLEZW-00-0000-0B0PT227F
90-CRI Minimum EasyWhite	3000K	T5	260	30H	XMLEZW-00-0000-0B0UT530H	30F	XMLEZW-00-0000-0B0UT530F
		T4	240		XMLEZW-00-0000-0B0UT430H		XMLEZW-00-0000-0B0UT430F
		T3	220		XMLEZW-00-0000-0B0UT330H		XMLEZW-00-0000-0B0UT330F
		T2	200		XMLEZW-00-0000-0B0UT230H		XMLEZW-00-0000-0B0UT230F
	2700K	T4	240	27H	XMLEZW-00-0000-0B0UT427H	27F	XMLEZW-00-0000-0B0UT427F
		T3	220		XMLEZW-00-0000-0B0UT327H		XMLEZW-00-0000-0B0UT327F
		T2	200		XMLEZW-00-0000-0B0UT227H		XMLEZW-00-0000-0B0UT227F
		S6	180		XMLEZW-00-0000-0B0US627H		XMLEZW-00-0000-0B0US627F

Notes:

For Standard CRI parts, the typical CRI is 80 for 4000-3500K CCT parts and typical CRI is 82 for 3000K - 2700K CCT

Cree maintains a tolerance of $\pm 7\%$ on flux and power measurements.

Cree maintains a tolerance of ± 2 on CRI measurements.

FLUX CHARACTERISTICS, STANDARD ORDER CODES AND BINS, 12 VOLT XM-L EZW (350 MA, T_J =85° C)

The following table provides the order codes for 12 Volt XLamp XM-L EZW LEDs.

Color	CCT Range	Base Order Codes Min Luminous Flux @ 350 mA, 85° C		2-Step Order Code		4-Step Order Code		
		Group	Flux (lm)	Chromaticity Region		Chromaticity Region		
Standard CRI EasyWhite	4000K	U4	340	40H	XMLEZW-00-0000-0D00U440H	40F	XMLEZW-00-0000-0D00U440F	
		U3	320		XMLEZW-00-0000-0D00U340H		XMLEZW-00-0000-0D00U340F	
		U2	300		XMLEZW-00-0000-0D00U240H		XMLEZW-00-0000-0D00U240F	
	3500K	U3	320	35H	XMLEZW-00-0000-0D00U335H	35F	XMLEZW-00-0000-0D00U335F	
		U2	300		XMLEZW-00-0000-0D00U235H		XMLEZW-00-0000-0D00U235F	
		T6	280		XMLEZW-00-0000-0D00T635H		XMLEZW-00-0000-0D00T635F	
	3000K	U3	320	30H	XMLEZW-00-0000-0D00U330H	30F	XMLEZW-00-0000-0D00U330F	
		U2	300		XMLEZW-00-0000-0D00U230H		XMLEZW-00-0000-0D00U230F	
		T6	280		XMLEZW-00-0000-0D00T630H		XMLEZW-00-0000-0D00T630F	
		T5	260		XMLEZW-00-0000-0D00T530H		XMLEZW-00-0000-0D00T530F	
	2700K	U2	300	27H	XMLEZW-00-0000-0D00U227H	27F	XMLEZW-00-0000-0D00U227F	
		T6	280		XMLEZW-00-0000-0D00T627H		XMLEZW-00-0000-0D00T627F	
		T5	260		XMLEZW-00-0000-0D00T527H		XMLEZW-00-0000-0D00T527F	
		T4	240		XMLEZW-00-0000-0D00T427H		XMLEZW-00-0000-0D00T427F	
	80-CRI Minimum EasyWhite	4000K	U4	340	40H	XMLEZW-00-0000-0D0HU440H	40F	XMLEZW-00-0000-0D0HU440F
			U3	320		XMLEZW-00-0000-0D0HU340H		XMLEZW-00-0000-0D0HU340F
U2			300	XMLEZW-00-0000-0D0HU240H		XMLEZW-00-0000-0D0HU240F		
3500K		U3	320	35H	XMLEZW-00-0000-0D0HU335H	35F	XMLEZW-00-0000-0D0HU335F	
		U2	300		XMLEZW-00-0000-0D0HU235H		XMLEZW-00-0000-0D0HU235F	
		T6	280		XMLEZW-00-0000-0D0HT635H		XMLEZW-00-0000-0D0HT635F	
		T5	260		XMLEZW-00-0000-0D0HT535H		XMLEZW-00-0000-0D0HT535F	
3000K		U3	320	30H	XMLEZW-00-0000-0D0HU330H	30F	XMLEZW-00-0000-0D0HU330F	
		U2	300		XMLEZW-00-0000-0D0HU230H		XMLEZW-00-0000-0D0HU230F	
		T6	280		XMLEZW-00-0000-0D0HT630H		XMLEZW-00-0000-0D0HT630F	
		T5	260		XMLEZW-00-0000-0D0HT530H		XMLEZW-00-0000-0D0HT530F	
2700K		U2	300	27H	XMLEZW-00-0000-0D0HU227H	27F	XMLEZW-00-0000-0D0HU227F	
		T6	280		XMLEZW-00-0000-0D0HT627H		XMLEZW-00-0000-0D0HT627F	
		T5	260		XMLEZW-00-0000-0D0HT527H		XMLEZW-00-0000-0D0HT527F	
		T4	240		XMLEZW-00-0000-0D0HT427H		XMLEZW-00-0000-0D0HT427F	

Color	CCT Range	Base Order Codes Min Luminous Flux @ 350 mA, 85° C		2-Step Order Code		4-Step Order Code	
		Group	Flux (lm)	Chromaticity Region		Chromaticity Region	
85-CRI Minimum EasyWhite	3000K	T6	280	30H	XMLEZW-00-0000-0D0PT630H	30F	XMLEZW-00-0000-0D0PT630F
		T5	260		XMLEZW-00-0000-0D0PT530H		XMLEZW-00-0000-0D0PT530F
		T4	240		XMLEZW-00-0000-0D0PT430H		XMLEZW-00-0000-0D0PT430F
		T3	220		XMLEZW-00-0000-0D0PT330H		XMLEZW-00-0000-0D0PT330F
	2700K	T5	260	27H	XMLEZW-00-0000-0D0PT527H	27F	XMLEZW-00-0000-0D0PT527F
		T4	240		XMLEZW-00-0000-0D0PT427H		XMLEZW-00-0000-0D0PT427F
		T3	220		XMLEZW-00-0000-0D0PT327H		XMLEZW-00-0000-0D0PT327F
		T2	200		XMLEZW-00-0000-0D0PT227H		XMLEZW-00-0000-0D0PT227F
90-CRI Minimum EasyWhite	3000K	T5	260	30H	XMLEZW-00-0000-0D0UT530H	30F	XMLEZW-00-0000-0D0UT530F
		T4	240		XMLEZW-00-0000-0D0UT430H		XMLEZW-00-0000-0D0UT430F
		T3	220		XMLEZW-00-0000-0D0UT330H		XMLEZW-00-0000-0D0UT330F
		T2	200		XMLEZW-00-0000-0D0UT230H		XMLEZW-00-0000-0D0UT230F
	2700K	T4	240	27H	XMLEZW-00-0000-0D0UT427H	27F	XMLEZW-00-0000-0D0UT427F
		T3	220		XMLEZW-00-0000-0D0UT327H		XMLEZW-00-0000-0D0UT327F
		T2	200		XMLEZW-00-0000-0D0UT227H		XMLEZW-00-0000-0D0UT227F
		S6	180		XMLEZW-00-0000-0D0US627H		XMLEZW-00-0000-0D0US627F

Notes:

For Standard CRI parts, the typical CRI is 80 for 4000-3500K CCT parts and typical CRI is 82 for 3000K - 2700K CCT
 Cree maintains a tolerance of $\pm 7\%$ on flux and power measurements.
 Cree maintains a tolerance of ± 2 on CRI measurements.

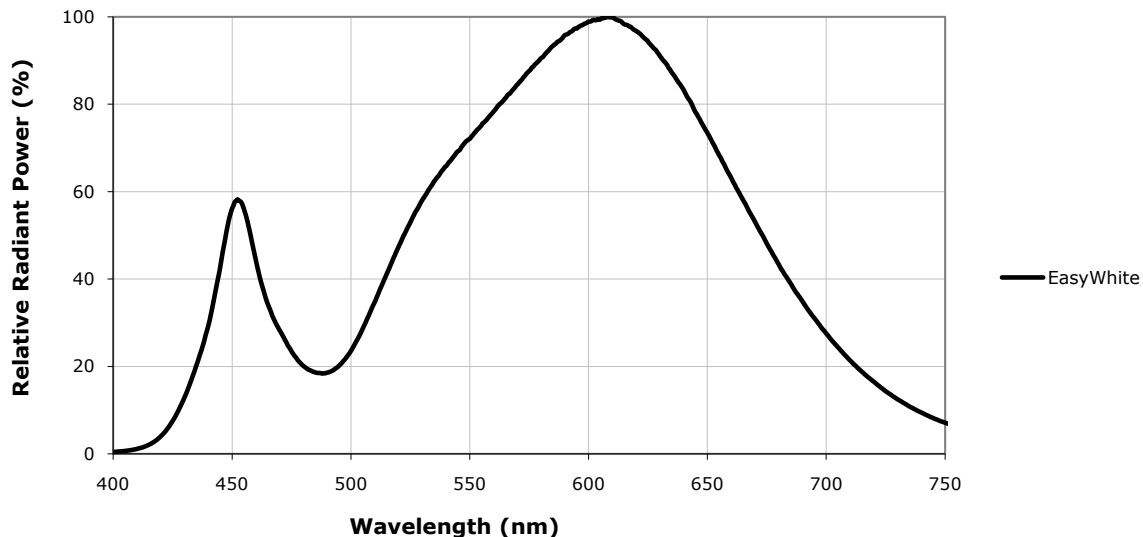
RELATIVE SPECTRAL POWER DISTRIBUTION (3000K CCT, CRI 80)

RELATIVE FLUX VS. JUNCTION TEMPERATURE (6V - $I_f = 700$ MA; 12V - $I_f = 350$ MA;)

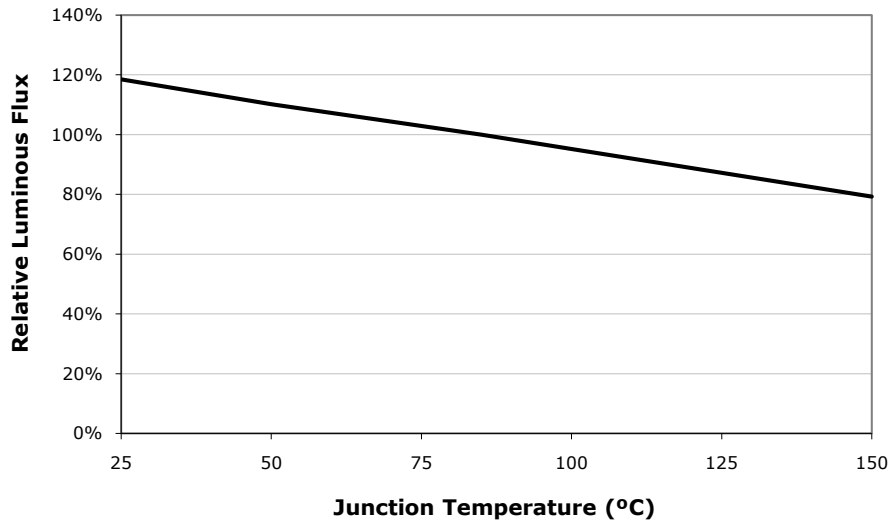

ELECTRICAL CHARACTERISTICS ($T_j = 85^\circ\text{C}$)

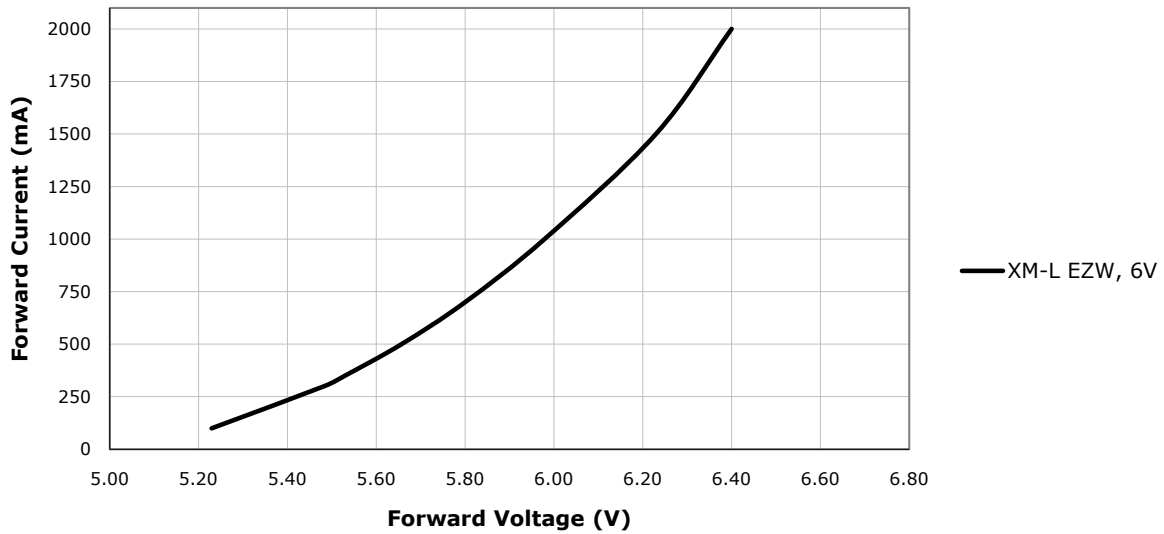

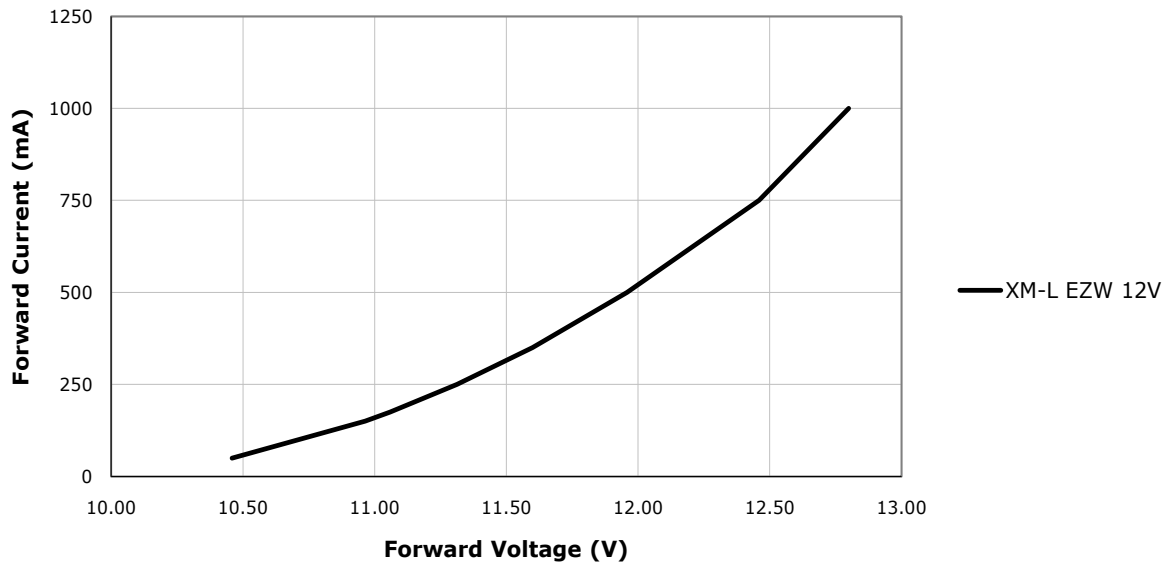

RELATIVE FLUX VS. CURRENT ($T_j = 85^\circ\text{C}$)

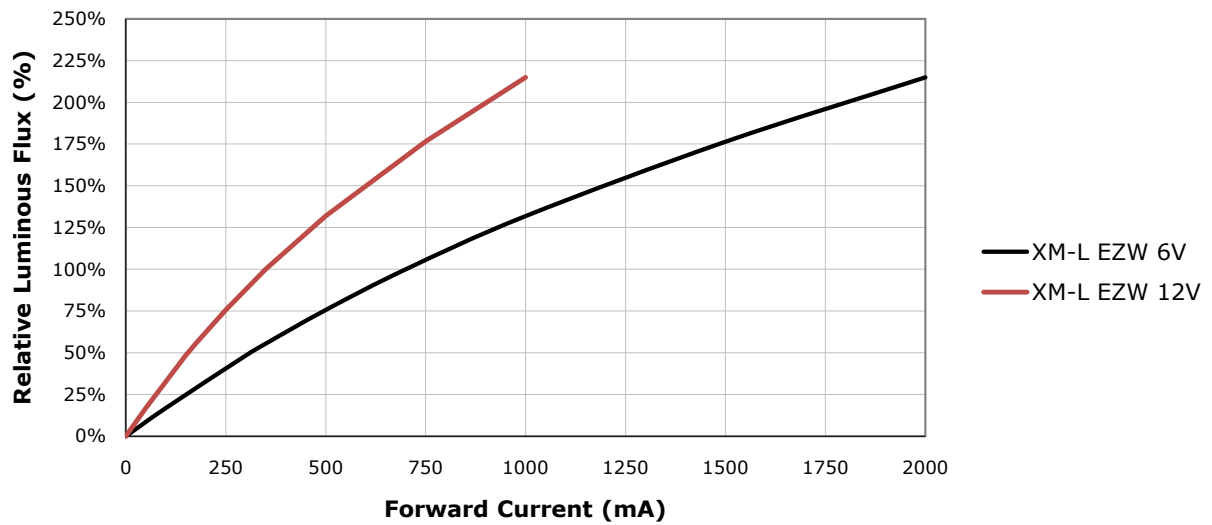

RELATIVE CHROMATICITY VERSUS CURRENT AND TEMPERATURE (CRI 80)

XM-L EZW 6V

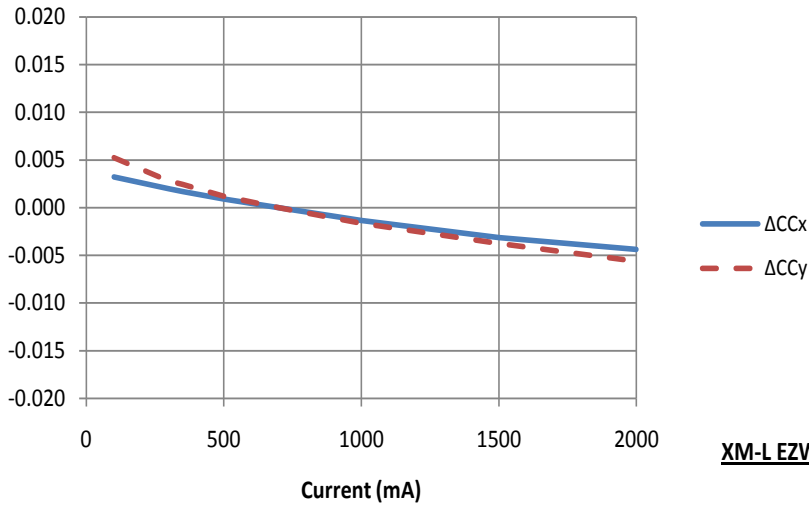

XM-L EZW 12V

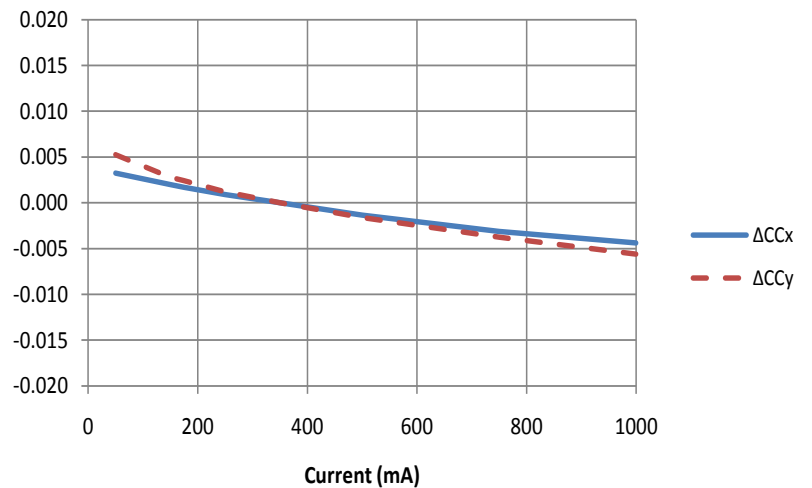

XM-L EZW, 6V, 12V

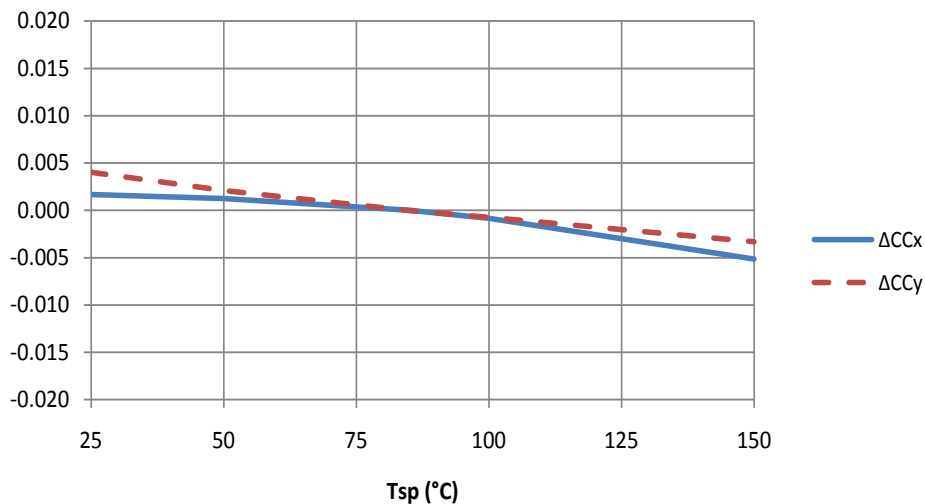

TYPICAL SPATIAL DISTRIBUTION

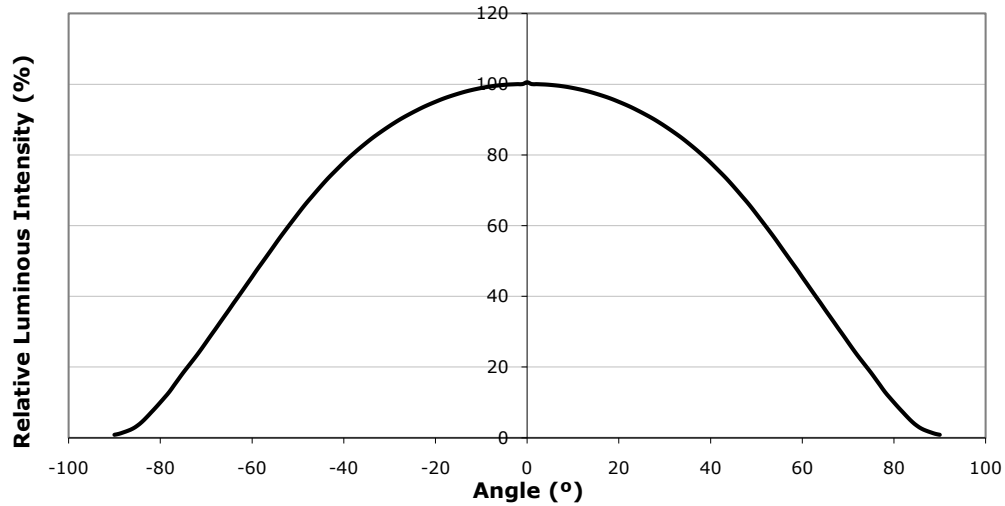

THERMAL DESIGN

The maximum forward current is determined by the thermal resistance between the LED junction and ambient. It is crucial for the end product to be designed in a manner that minimizes the thermal resistance from the solder point to ambient in order to optimize lamp life and optical characteristics.

XLamp XM-L EZW, 6V

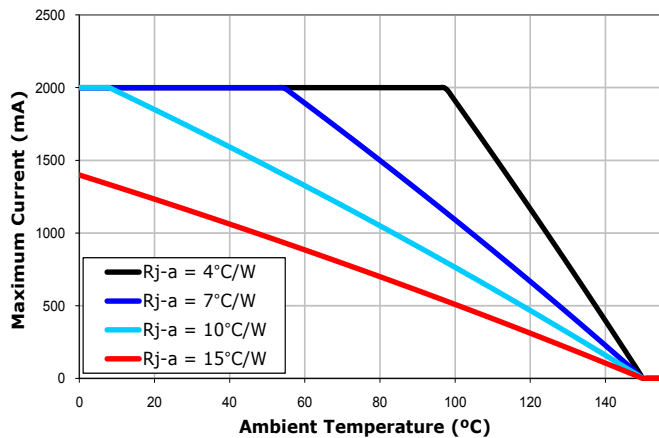

XLamp XM-L EZW, 12V

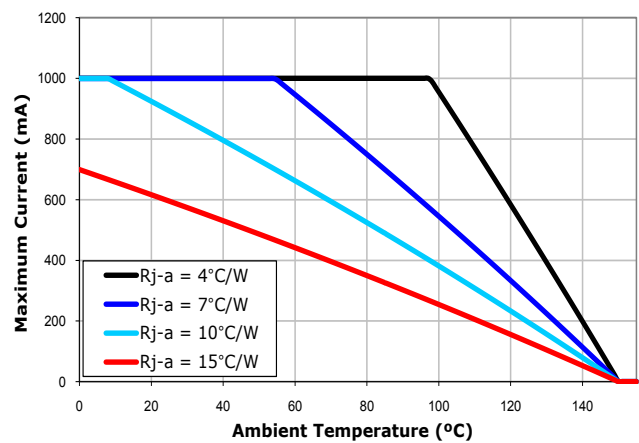

PERFORMANCE GROUPS – BRIGHTNESS ($T_j = 85^{\circ}\text{C}$)

XLamp XM-L EasyWhite LEDs are tested for luminous flux and placed into one the following bins.

Group Code	Min. Luminous Flux@700mA, 6V (@350mA, 12V)	Max. Luminous Flux@700mA, 6V (@350mA, 12V)
S6	180	200
T2	200	220
T3	220	240
T4	240	260
T5	260	280
T6	280	300
U2	300	320
U3	320	340
U4	340	360
U5	360	380
U6	380	400

PERFORMANCE GROUPS – CHROMATICITY ($T_j = 85^{\circ}\text{C}$)

XLamp XM-L EasyWhite LEDs are tested for chromaticity and placed into one of the regions defined by the following bounding coordinates.

Code	CCT	x	y
40F	4000 K	0.3744	0.3685
		0.3782	0.3837
		0.3912	0.3917
		0.3863	0.3758
35F	3500 K	0.3981	0.3800
		0.4040	0.3966
		0.4186	0.4037
		0.4116	0.3865
30F	3000 K	0.4242	0.3919
		0.4322	0.4096
		0.4449	0.4141
		0.4359	0.3960
27F	2700 K	0.4475	0.3994
		0.4573	0.4178
		0.4695	0.4207
		0.4589	0.4021

Code	CCT	x	y
40H	4000 K	0.3784	0.3741
		0.3804	0.3818
		0.3867	0.3857
		0.3844	0.3778
35H	3500 K	0.4030	0.3857
		0.4061	0.3941
		0.4132	0.3976
		0.4099	0.3890
30H	3000 K	0.4291	0.3973
		0.4333	0.4062
		0.4395	0.4084
		0.4351	0.3994
27H	2700 K	0.4528	0.4046
		0.4578	0.4138
		0.4638	0.4152
		0.4586	0.4060

CREE EASYWHITE COLOR TEMPERATURES PLOTTED ON THE 1931 CIE CURVE ($T_j = 85^\circ\text{C}$)

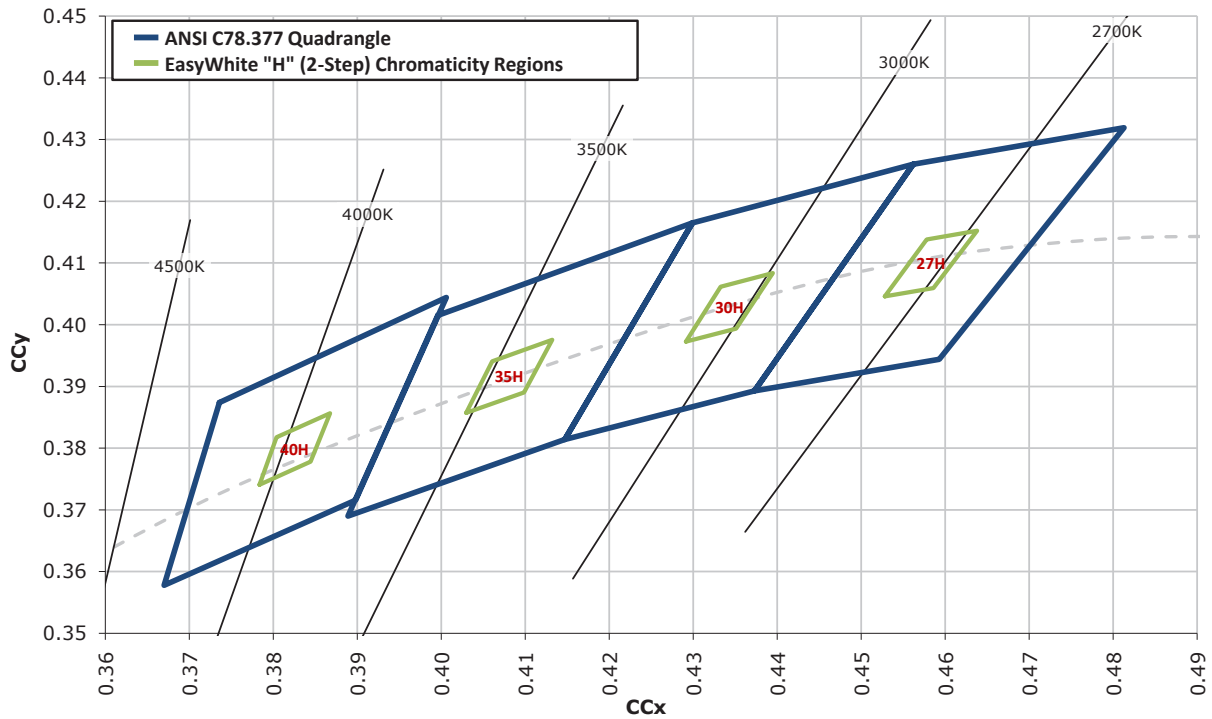
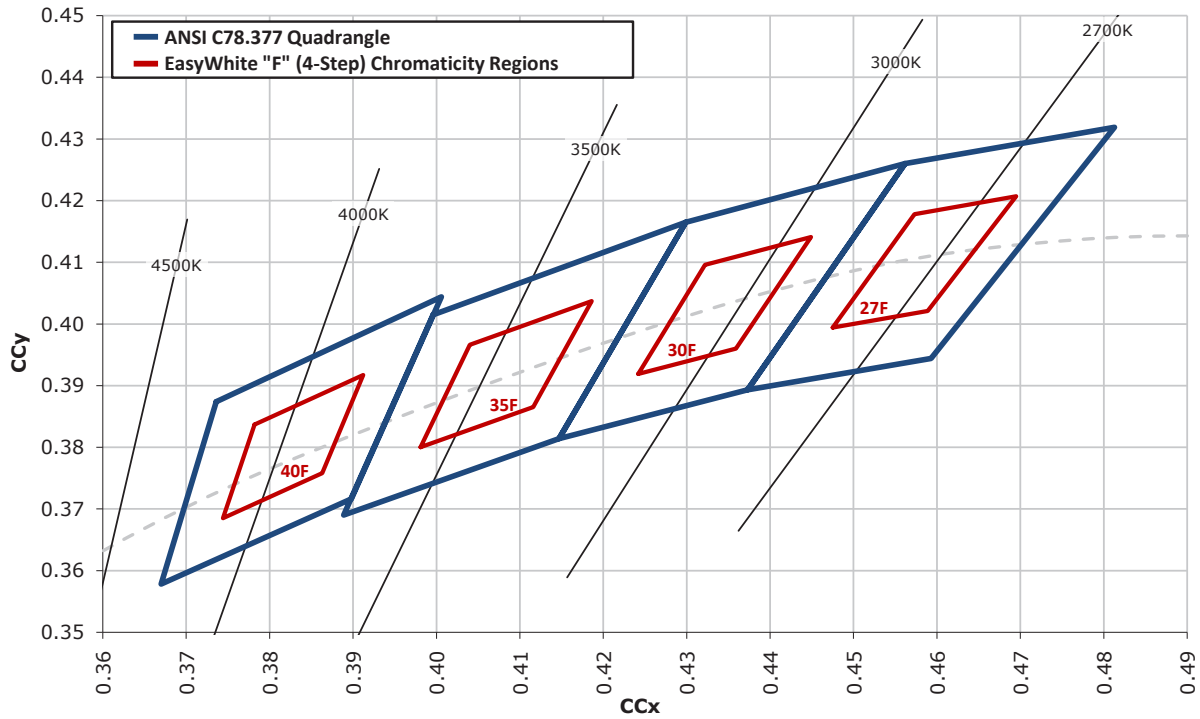

Copyright © 2011 Cree, Inc. All rights reserved. The information in this document is subject to change without notice. Cree, the Cree logo and XLamp are registered trademarks and EasyWhite is a trademark of Cree, Inc. This is a preliminary, non-binding product specification provided for informational purposes only and is subject to change without notice. This product is unreleased and is provided "as is" without warranty.

BIN AND ORDER CODE FORMAT

Bin codes and order codes are configured as follows:

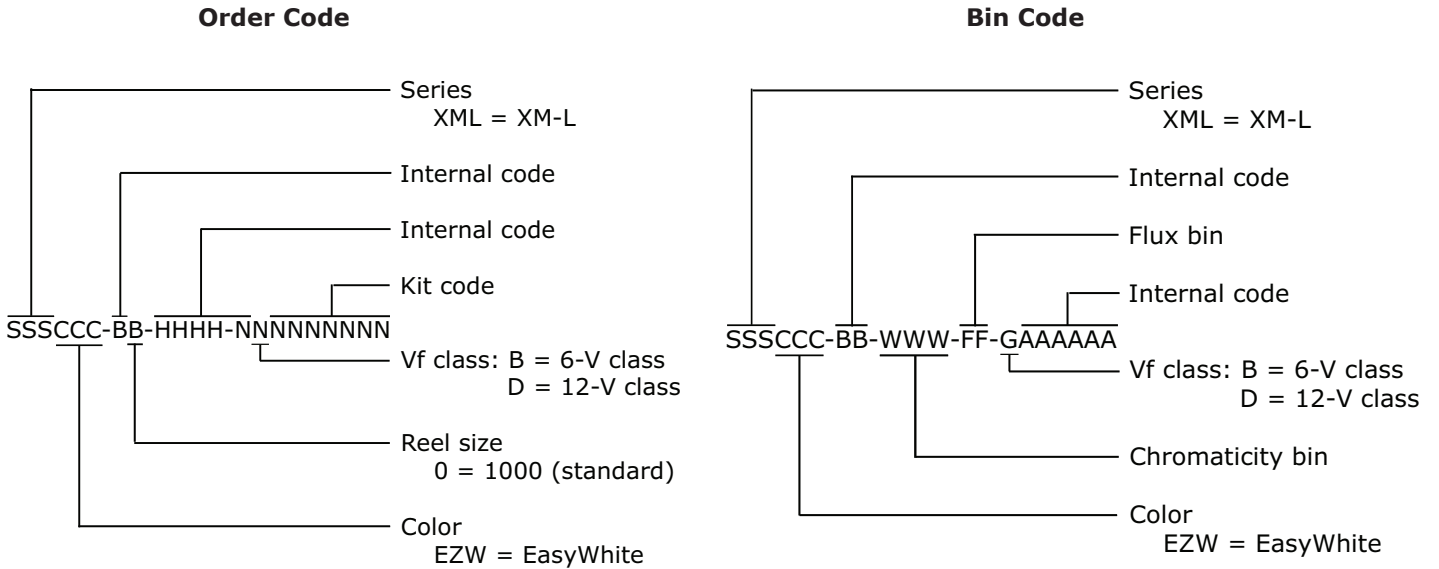

REFLOW SOLDERING CHARACTERISTICS

In testing, Cree has found XLamp XM-L LEDs to be compatible with JEDEC J-STD-020C, using the parameters listed below. As a general guideline, Cree recommends that users follow the recommended soldering profile provided by the manufacturer of solder paste used.

Note that this general guideline may not apply to all PCB designs and configurations of reflow soldering equipment.

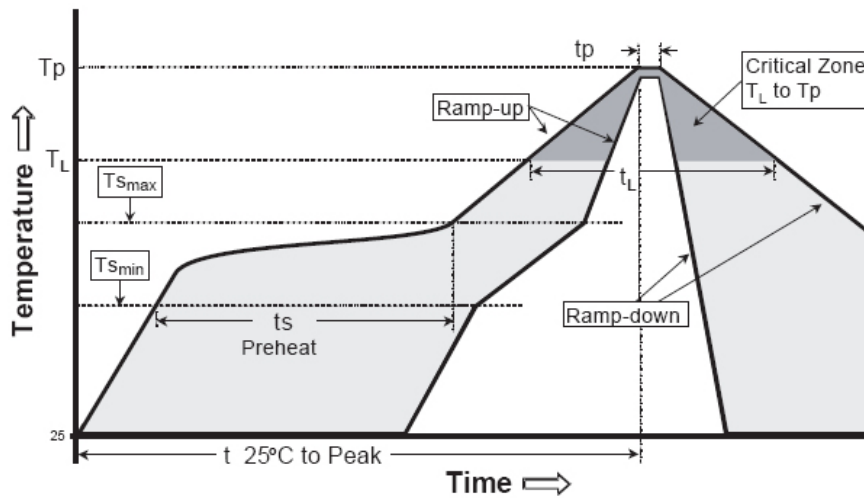

IPC/JEDEC J-STD-020C

Profile Feature	Lead-Based Solder	Lead-Free Solder
Average Ramp-Up Rate ($T_{s_{max}}$ to T_p)	3°C/second max.	3°C/second max.
Preheat: Temperature Min ($T_{s_{min}}$)	100°C	150°C
Preheat: Temperature Max ($T_{s_{max}}$)	150°C	200°C
Preheat: Time ($t_{s_{min}}$ to $t_{s_{max}}$)	60-120 seconds	60-180 seconds
Time Maintained Above: Temperature (T_L)	183°C	217°C
Time Maintained Above: Time (t_L)	60-150 seconds	60-150 seconds
Peak/Classification Temperature (T_p)	215°C	260°C
Time Within 5°C of Actual Peak Temperature (t_p)	10-30 seconds	20-40 seconds
Ramp-Down Rate	6°C/second max.	6°C/second max.
Time 25°C to Peak Temperature	6 minutes max.	8 minutes max.

Note: All temperatures refer to the topside of the package, measured on the package body surface.

NOTES

Moisture Sensitivity

In testing, Cree has found XLamp XM-L LEDs to have unlimited floor life in conditions $\leq 30^\circ\text{C}$ / 85% relative humidity (RH). Moisture testing included a 168-hour soak at 85°C / 85% RH followed by 3 reflow cycles, with visual and electrical inspections at each stage.

Vision Advisory Claim

WARNING. Do not look at exposed lamp in operation. Eye injury can result. For more information about LEDs and eye safety, please refer to the Cree LED Eye Safety application note.

Lumen Maintenance Projections

For XLamp XM-L EZW (6V) Cree currently recommends a maximum drive current of 1000 mA in designs seeking the ENERGY STAR* 35,000 hour lifetime rating ($\geq 94.1\%$ luminous flux @ 6000 hours) or 25,000-hour lifetime rating ($\geq 91.8\%$ luminous flux @ 6000 hours). For XLamp XM-L EZW (12V) Cree currently recommends a maximum drive current of 500 mA in designs seeking the ENERGY STAR* 35,000 hour lifetime rating ($\geq 94.1\%$ luminous flux @ 6000 hours) or 25,000-hour lifetime rating ($\geq 91.8\%$ luminous flux @ 6000 hours). Please consult the XLamp Long-Term Lumen Maintenance application note for more details on Cree's lumen maintenance testing and forecasting. Please read the XLamp Thermal Management application note for details on how thermal design, ambient temperature, and drive current affect the LED junction temperature.

* These lifetime ratings are based on the current ENERGY STAR Solid State Lighting Luminaires V1.1 (December 12, 2008) and ENERGY STAR Integral LED Lamps V1.0 (December 3, 2009) lumen maintenance criteria.

MECHANICAL DIMENSIONS

All measurements are ± 0.13 mm unless otherwise indicated.

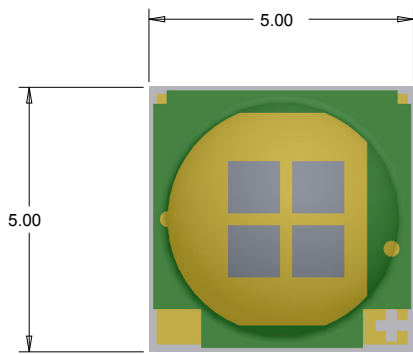
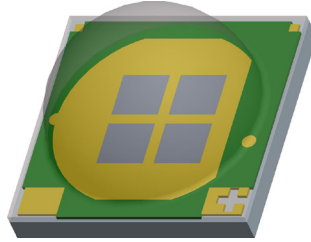

Top View

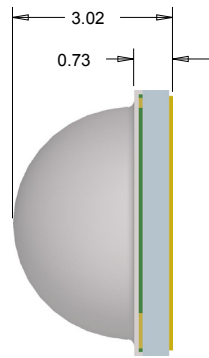

Side View

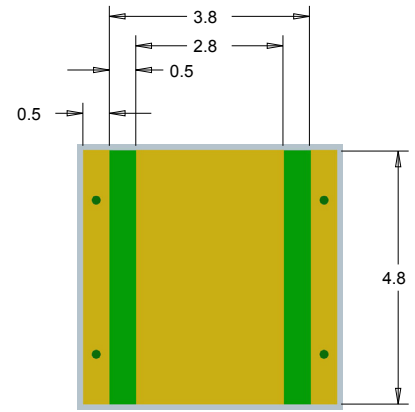

Bottom View

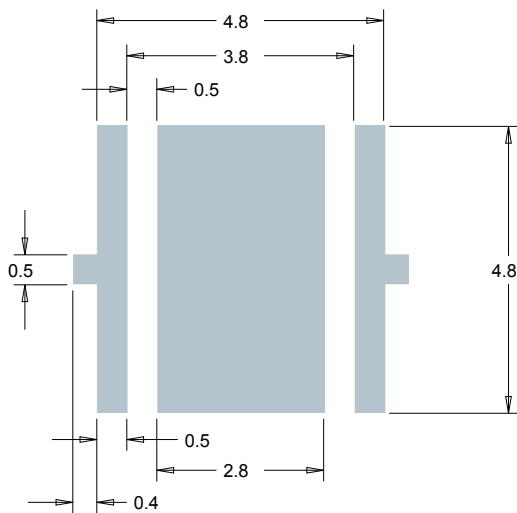

Recommended PCB Solder Pad

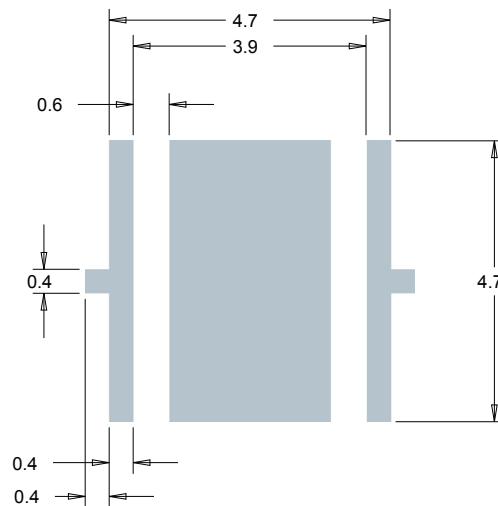

**Recommended Stencil Pattern
(Shaded Area Is Open)**

TAPE AND REEL

All dimensions in mm.

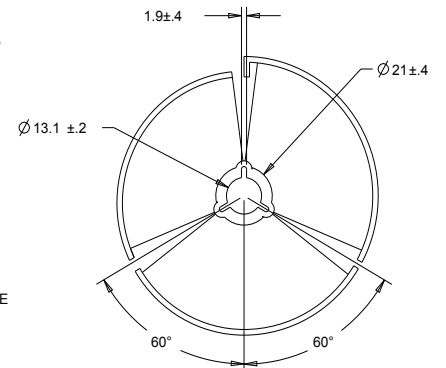
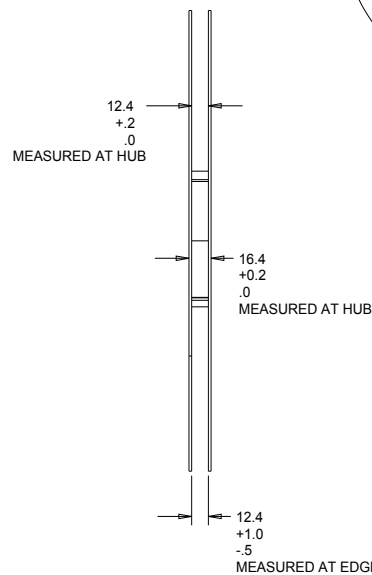
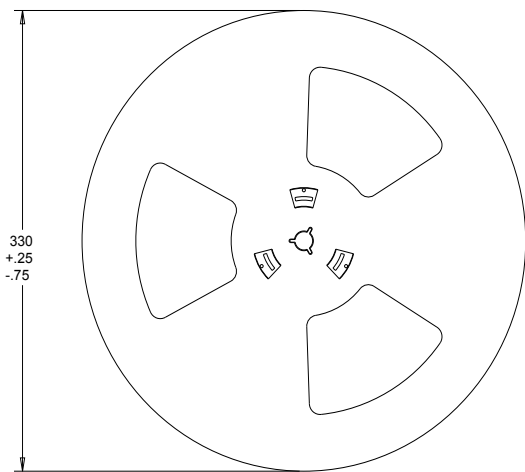
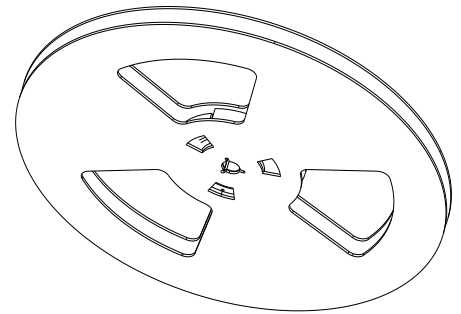
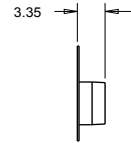
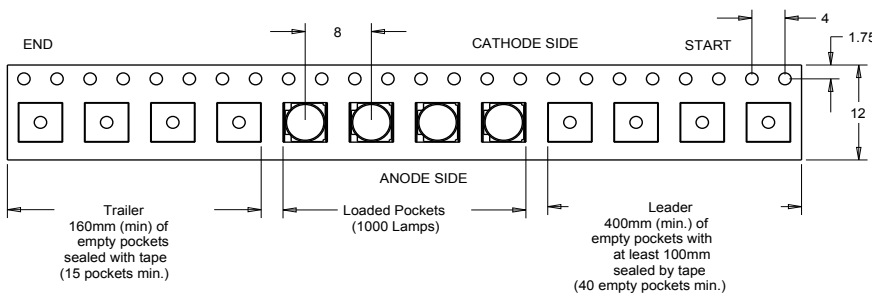
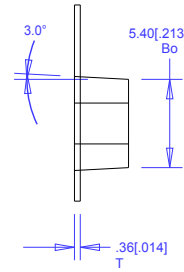
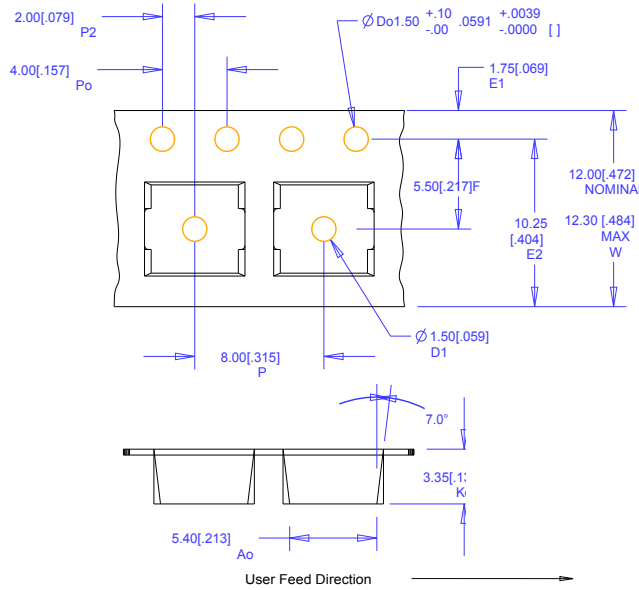

PACKAGING

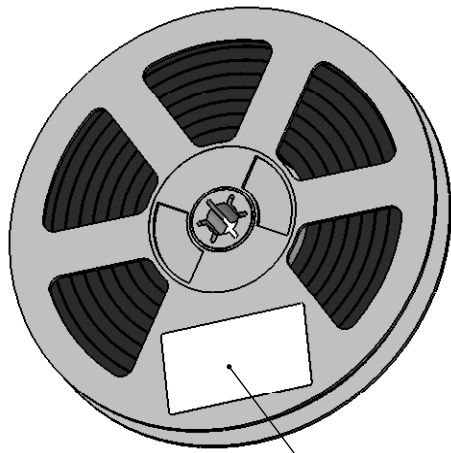

Label with Cree Bin Code, Qty, Lot #

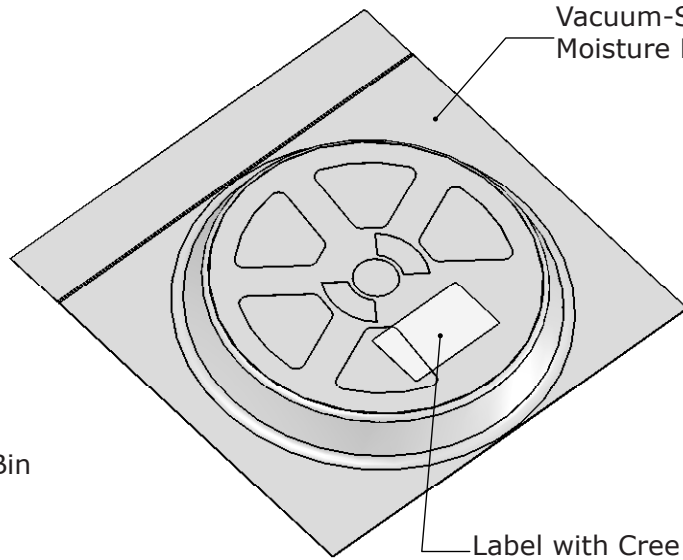

Vacuum-Sealed Moisture Barrier Bag

Label with Cree Bin Code, Qty, Lot #

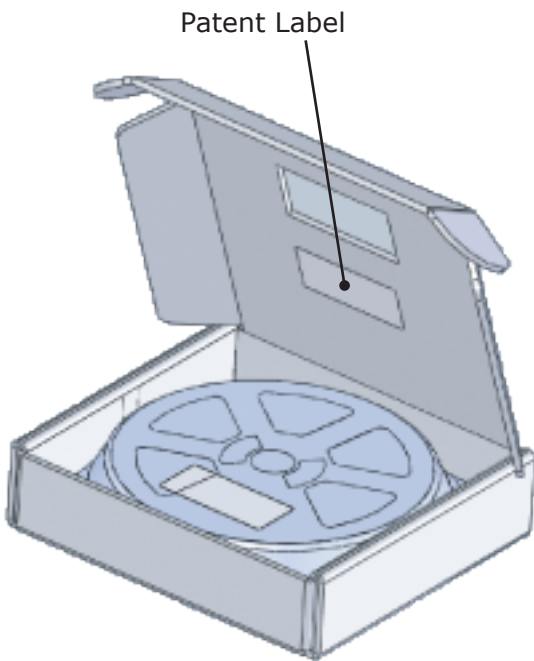

Patent Label

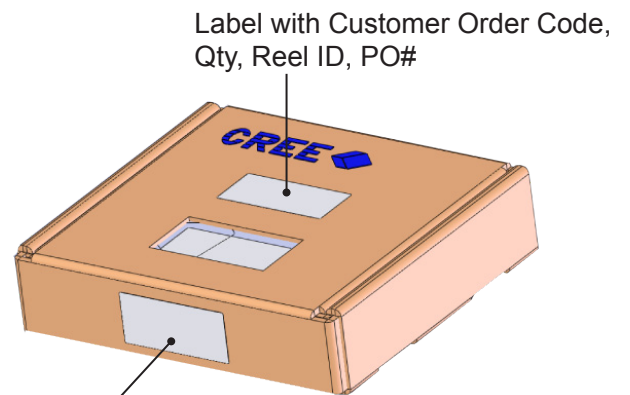

Label with Customer Order Code, Qty, Reel ID, PO#

Label with Cree Bin Code, Qty, Lot #