

E40 Series

Diameter ϕ 40mm Shaft type/Hollow type/Built-in type Incremental Rotary encoder

Features

- Easy installation at narrow space
- Small moment of inertia
- Power supply : 5VDC, 12-24VDC \pm 5%
- Various output types

⚠ Please read "Caution for your safety" in operation manual before using.



Ordering information

E40	H	8	5000	3	N	24	
Series	Shaft type	Hollow type	Pulse/1Revolution	Output phase	Output	Power supply	Cable
S: Shaft type H: Hollow type HB: Hollow built-in type	External 6: ϕ 6mm 8: ϕ 8mm	Inner 6: ϕ 6mm 8: ϕ 8mm 10: ϕ 10mm 12: ϕ 12mm	Refer to resolution	2: A, B 3: A, B, Z 4: A, \bar{A} , B, \bar{B} 6: A, \bar{A} , B, \bar{B} , Z, \bar{Z}	T: Totem pole output N: NPN open collector output V: Voltage output L: Line driver output(*)	5 : 5VDC \pm 5% 24: 12-24VDC \pm 5%	No mark: Normal type (*) C: Cable outgoing connector type
* Standard : E40S6- [PULSE] -3-N-24 E40H8- [PULSE] -3-N-24 E40HB8- [PULSE] -3-N-24			* Standard: A, B, Z * The power of Line driver is only for 5VDC			* Cable length : 250mm	

Specifications

Item	Diameter ϕ 40mm shaft/hollow shaft/built-in type of Incremental rotary encoder		
Resolution (P/R)	(Note1) *1, *2, *5, 10, *12, 15, 20, 23, 25, 30, 35, 40, 45, 50, 60, 75, 100, 120, 150, 192, 200, 240, 250, 256, 300, 360, 400, 500, 512, 600, 800, 1000, 1024, 1200, 1500, 1800, 2000, 2048, 2500, 3000, 3600, 5000 (Not indicated resolution is customizable.)		
Electrical specification	Output phase	A, B, Z phase (Line driver : A, \bar{A} , B, \bar{B} , Z, \bar{Z} phase)	
	Phase difference of output	Phase difference between A and B : $\frac{T}{4} \pm \frac{T}{8}$ (T=1 cycle of A phase)	
	Control output	Totem pole output	• Low \Rightarrow Load current: Max. 30mA, Residual voltage : Max. 0.4VDC • High \Rightarrow Load current: Max. 10mA, Output voltage (Power supply 5VDC): Min. (Power supply -2.0)VDC, Output voltage (Power supply 12-24VDC): Min. (Power supply -3.0)VDC
		NPN open collector output	Load current : Max. 30mA, Residual voltage : Max. 0.4VDC
		Voltage output	Load current : Max. 10mA, Residual voltage : Max. 0.4VDC
		Line driver output	Low \Rightarrow Load current : Max. 20mA, Residual : Max. 0.5VDC High \Rightarrow Load current : Max. -20mA, Output voltage : Min. 2.5VDC
	Response time (Rise/Fall)	Totem pole output	Max. 1 μ s
		NPN open collector output	Max. 1 μ s
		Voltage output	Max. 1 μ s
		Line driver output	Max. 0.5 μ s
	Max. Response frequency	300kHz	
	Power supply	• 5VDC \pm 5% (Ripple P-P: Max. 5%) • 12-24VDC \pm 5% (Ripple P-P: Max. 5%)	
	Current consumption	Max. 80mA (disconnection of the load), Line driver output: Max. 50mA (disconnection of the load)	
Insulation resistance	Min. 100M Ω (at 500VDC mega)		
Dielectric strength	750VAC 50/60Hz for 1 minute (Between all terminals and case)		
Connection	Cable outgoing type, 200mm cable outgoing connector type		
Mechanical specification	Starting torque	Shaft Type : Max. 40gf \cdot cm (0.004N \cdot m), Hole Type : Max. 50gf \cdot cm (0.005N \cdot m)	
	Rotor inertia	Max. 40g \cdot cm ² (4 \times 10 ⁻⁶ kg \cdot m ²)	
	Shaft loading	Radial : Max. 2kgf, Thrust : Max. 1kgf	
	Max. allowable revolution	(Note2)	5000rpm
Vibration	1.5mm amplitude at frequency of 10 ~ 55Hz in each of X, Y, Z directions for 2 hours		
Shock	Max. 50G		
Ambient temperature	-10 ~ 70 $^{\circ}$ C (at non-freezing status), Storage: -25 ~ 85 $^{\circ}$ C		
Ambient humidity	35~85%RH, Storage: 35~90%RH		
Protection	IP50 (IEC standard)		
Cable	ϕ 5mm, 5P, Length : 2m, Shield cable (Line driver output : ϕ 5mm, 8P)		
Accessory	• Shaft type: ϕ 6mm coupling standard, ϕ 8mm coupling (Sold separately) • Hole type : Bracket		
Unit weight	Approx. 160g		
Approval	CE (Except for Line driver output)		

* **(Note1)** ' * ' pulse is only for A, B phase (Line Driver output is for A, \bar{A} , B, \bar{B} phase)

* **(Note2)** Max. allowable revolution \geq Max. response revolution **[**Max. response revolution (rpm) = $\frac{\text{Max. response frequency}}{\text{Resolution}} \times 60 \text{ sec}$ **]**

Incremental ϕ 40mm Shaft/Hollow Shaft/Built-in Type

Control output diagram

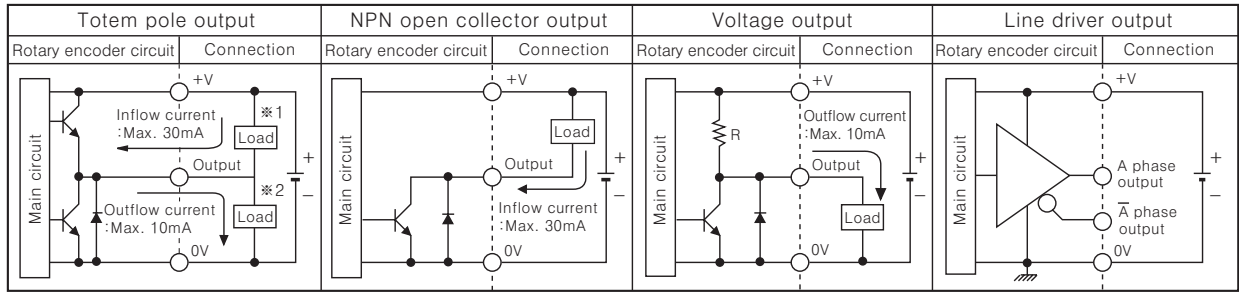

- ⊠ Totem pole output type can be used for NPN open collector output type(※1) or Voltage output type(※2).
- ⊠ All output circuits of A, B, Z phase is same. (Line driver output is A, \bar{A} , B, \bar{B} , Z, \bar{Z})

Output waveform

- Totem pole output / NPN open collector output / Voltage output

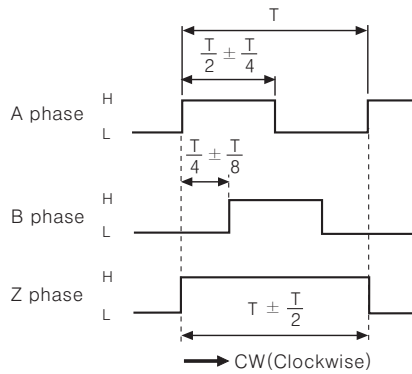

※CW : As viewed from the shaft

- Line driver output

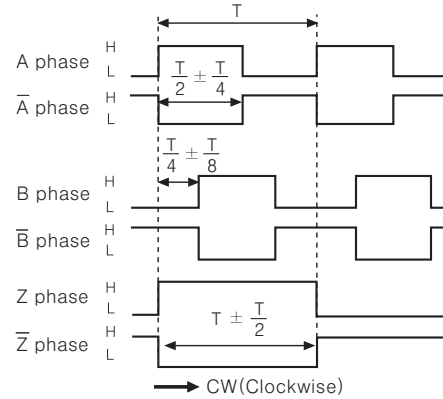

Connections

Normal type

- Totem pole output / NPN open collector output / Voltage output

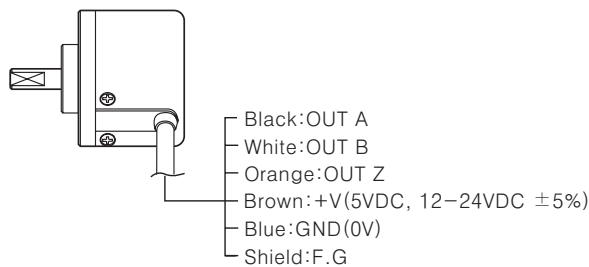

- ※ Unused wires must be insulated.
- ※ The metal case and shield wire of encoder should be grounded(F.G).

- Line driver output

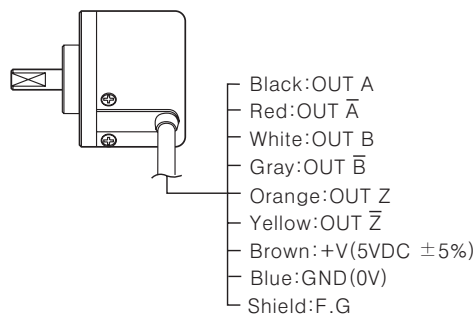

Cable outgoing connector type

- Totem pole output
- NPN open collector output
- Voltage output
- Line driver output

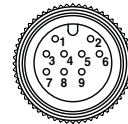
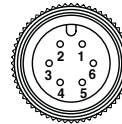

Totem pole output NPN open collector output Voltage output			Line driver output		
Pin No	Function	Cable color	Pin No	Function	Cable color
①	OUT A	Black	①	OUT A	Black
②	OUT B	White	②	OUT \bar{A}	Red
③	OUT Z	Orange	③	+V	Brown
④	+V	Brown	④	GND	Blue
⑤	GND	Blue	⑤	OUT B	White
⑥	F.G	Shield	⑥	OUT \bar{B}	Gray
			⑦	OUT Z	Orange
			⑧	OUT \bar{Z}	Yellow
			⑨	F.G	Shield

※F.G(Field Ground):It should be grounded separately.

(A) Counter

(B) Timer

(C) Temp. controller

(D) Power controller

(E) Panel meter

(F) Tacho/Speed/Pulse meter

(G) Display unit

(H) Sensor controller

(I) Switching power supply

(J) Proximity sensor

(K) Photo electric sensor

(L) Pressure sensor

(M) Rotary encoder

(N) Stepping motor & Driver & Controller

(O) Graphic panel

(P) Field network device

(Q) Production stoppage models & replacement

E40 Series

Dimensions

Normal type

Shaft type

(Unit:mm)

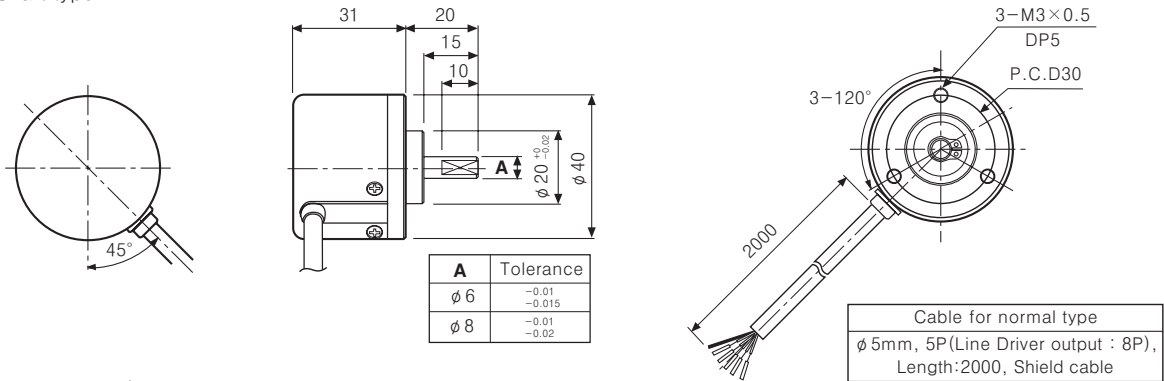

Hollow shaft / Hollow shaft built-in type

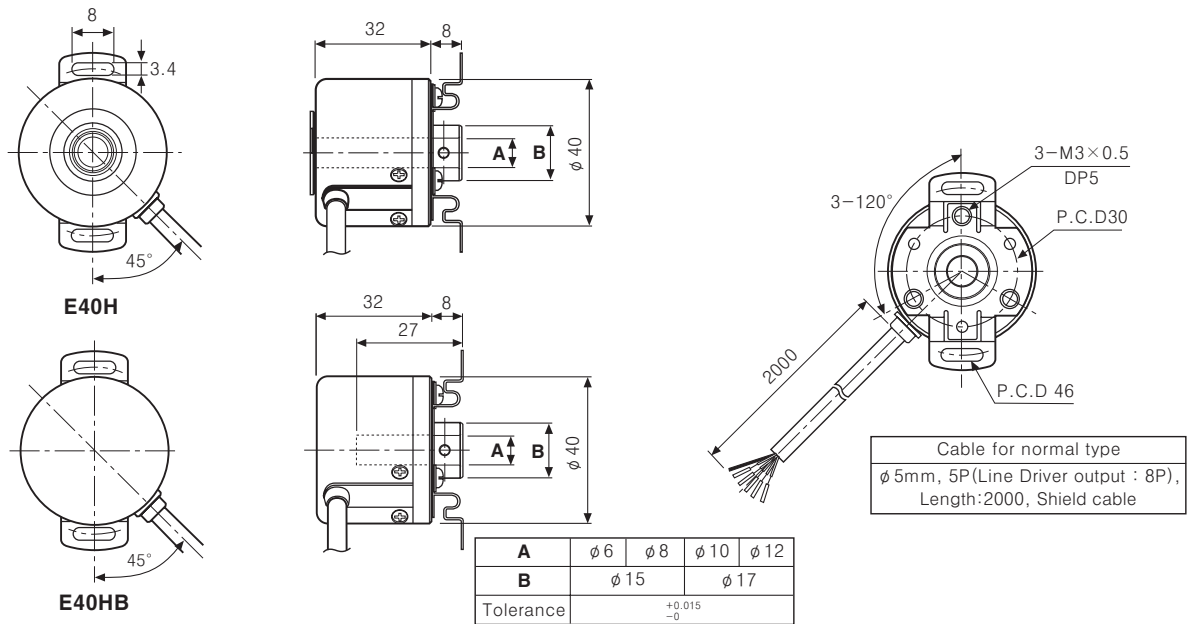

Cable outgoing connector type

Bracket

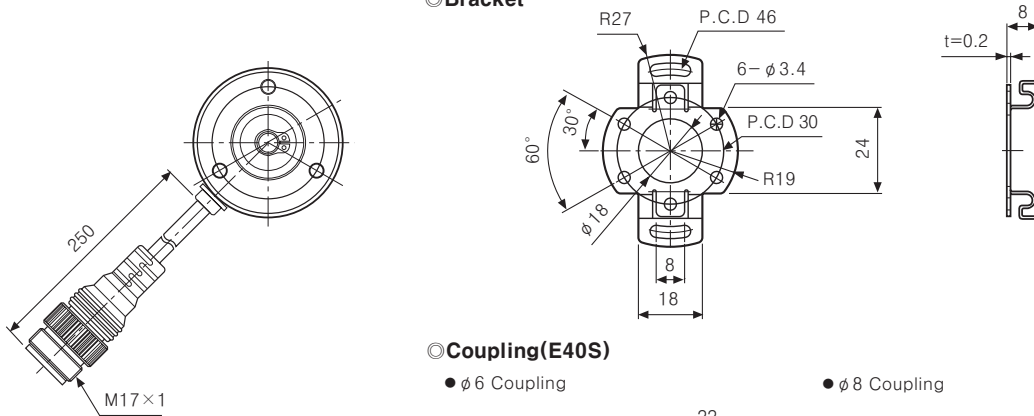

Coupling(E40S)

φ 6 Coupling

φ 8 Coupling

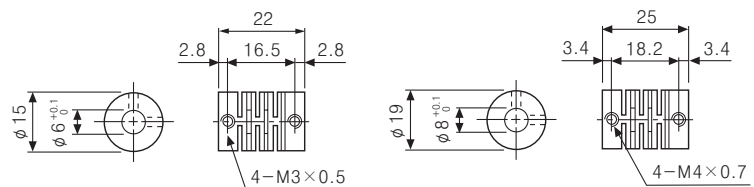

*Connector cable is customizable and see M-57 for specifications.