

DP Series DC Load Reversing Solid State Contactors

Crydom's advanced DC Switching Technology is now conveniently packaged in a High Power "H-Bridge" configuration with optional Soft Start/Ramp Up, Soft Stop/Ramp Down & Brake features for use in DC Load Reversing applications including motors, brakes, clutches, electro magnets, solenoids, plating baths and electrolytic cells. The DP Series Solid State DC Reversers are an all-solid-state design with 2.5 Kv Optical Isolation and incorporate low dissipation power FETs for fast and efficient Load control.

FEATURES

- Convenient FET switches in H-bridge configuration
- Built-in protective Forward/Reverse interlock function
- UL & IEC ratings for general use & Motor loads
- LED Status indicators for Operating Modes

MOUNTING INSTRUCTIONS (A)

Please read all installation instructions before using your DP Series Solid State Contactor (SSC).

- Choose one of the two mounting options and follow the instructions.

Mounting on Heat Sink

- Select adequate heat sink (see thermal derating curves). (B)
- Be sure to use thermal pad or grease between the SSC and the selected heat sink.
- DP Series Contactor mounting slots have a diameter of 0.2 in (5.0 mm). Four screws are needed (not included) to mount the SSC onto heat sink (See Fig. 1). Choose screw length considering the mounting surface and that DP Series baseplate thickness is 0.125 in (3.2 mm).

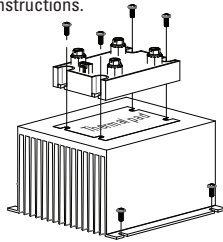

fig. 1 DP Series SSC mounted on HS053 heat sink(A)

- Before applying full torque tighten down all 4 screws until they contact the baseplate. Then, tighten them to 20 in-lbs (2.2 Nm) starting with one immediately followed by the one in the diagonally opposite corner. After the first 2 screws are completely tightened, proceed tightening the remaining 2 screws.
- For optimal thermal performance heat sink fins should be oriented vertically to natural airflow.

Mounting on Panel

- Locate the panel section on which the DP Series SSC will be mounted. Panel mount surface must provide adequate heat sinking capability. (B)
- Be sure to use thermal pad or grease between the SSC and the panel.
- DP Series Contactor mounting slots have a diameter of 0.2 in (5.0 mm). Four screws are needed (not included) to mount the SSC onto panel. Choose screw length considering the mounting surface and that DP Series baseplate thickness is 0.125 in (3.2 mm).
- Before applying full torque tighten down all 4 screws until they contact the baseplate. Then, tighten them to 20 in-lbs (2.2 Nm) starting with one immediately followed by the one in the diagonally opposite corner. After the first 2 screws are completely tightened, proceed tightening the remaining 2 screws.

WIRING DIAGRAM (C)

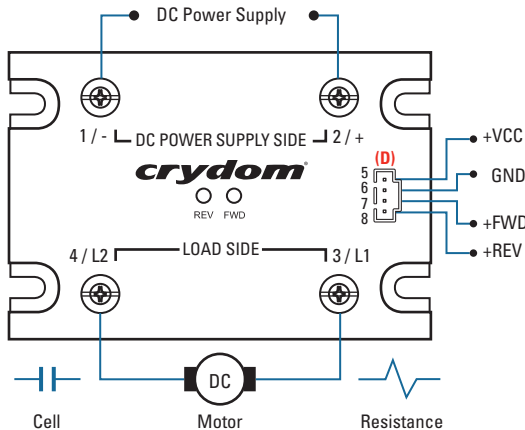

PART NUMBER NOMENCLATURE (E)

DP	4R	SB	60	D	40	B	H
Series	Function 4R: 4 Channel DC Reversing	Start Mode Blank: Start SA: Soft Start/Ramp Up, 0.2 sec SB: Soft Start/Ramp Up, 0.5 sec SC: Soft Start/Ramp Up, 1 sec	Rated Operating Voltage 60: 48 VDC	Control Voltage D: 4.5-15 VDC E: 18-32 VDC	Operational Current 20: 20 Amps 40: 40 Amps 60: 60 Amps	Stop Mode Blank: Stop Mode matches Start Mode B2: Dynamic Brake, 0.2 sec B5: Dynamic Brake, 0.5 sec B8: Dynamic Brake, 0.8 sec B: Dynamic Brake, Continuous	Thermal Pad Blank: Not Included H: Included
●	●	●	●	●	●	●	●
Required for valid part number	For options only and not required for valid part number						

DERATING CURVES (B)

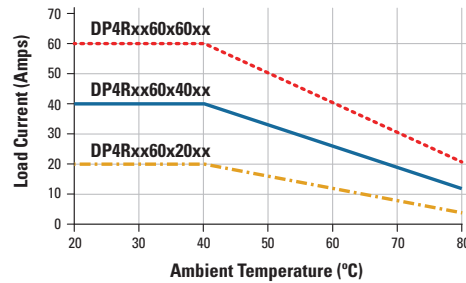

TABLE 1

DP Series Part No.	Required Heat Sink [°C/W]	Crydom Heat Sink Part No.
DP4Rxx60x20xx	1.5	HS103/HS103DR
DP4Rxx60x40xx	1.0	HS103/HS103DR
DP4Rxx60x60xx	0.5	HS053

TABLE 2

Status Functions	Green LED (Forward)	Yellow LED (Reverse)
Initial Logic Supply Voltage On	Flash Twice	Flash Twice
Forward ON	ON	OFF
Reverse ON	OFF	ON
Dynamic Brake	Flash Once	Flash Once
Interlocking	Flash 3x Intermittently	Flash 3x Intermittently

TABLE 3

DP Series Part No.	Output Terminal	Maximum Torque lbs in (N m)	Wire Size for Max. Ratings AWG (mm ²)
DP4Rxx60x20xx	Screw / Clamp Combo Type 10-32	20 (2.2)	12 (3.3)
DP4Rxx60x40xx	Hex Screw Type 1/4-20 with lock washers	25 (2.8)	8 (8.4)
DP4Rxx60x60xx	Hex Screw Type 1/4-20 with lock washers	25 (2.8)	6 (13.3)

TABLE 4

DP Series Part No.	Accessories					
	HK1	HS053	HS103 HS103DR	HSP-3 HSP-5	TRM1	TRM6
DP4Rxx60x20xx	◆		◆	◆		◆
DP4Rxx60x40xx	◆		◆	◆	◆	
DP4Rxx60x60xx	◆	◆	◆	◆	◆	

- (A) See compatible accessories in TABLE 4.
- (B) For maximum ratings use heat sink ratings in TABLE 1.
- (C) Terminal (3/L1) is (+) during Forward operation. Terminal (4/L2) is (+) during Reverse operation.
- (D) Suggested Input Mating Connector/Plug : Crimp Housing, Positive Latch (Molex 050579404).
- (E) For a complete description of available Operating Modes, see definitions on reverse side of this sheet.

OPERATING MODES

Start: When either FWD or REV Control signal is applied, and after Control Signal Validation Delay, DC power supply on terminals 1/- and 2/+ is directly connected to Load at terminals 3/L1 and 4/L2 with a polarity according to the control signal. The start option can be combined with Stop and/or Dynamic Brake options.

Stop: Load is disconnected from DC power supply. All FET switches (S1, S2, S3 & S4) inside the DP Series SSC are turned off. This simple Stop option is available only in combination with the simple Start option (suffix Blank).

Soft Start/Ramp Up: It is a modified Start where the DC power supply is connected to the load using a 200 Hz pulse width modulation with a duty cycle going from 10% to 100%. Soft Start/Ramp Up time is defined by SA, SB and SC suffixes. After Soft Start/Ramp Up time is elapsed, the Load will remain continuously energized for as long as FWD or REV Control signal is applied. This option can be combined with Soft Stop/Ramp Down and Dynamic Braking modes, but not with simple Stop.

Soft Stop/Ramp Down: It is a modified Stop where the DC power supply is disconnected from the Load using a 200 Hz pulse width modulation with a duty cycle going from 100% to 0%. After Soft Stop/Ramp Down time is elapsed,

the Load will remain continuously de-energized waiting for a new FWD or REV Control signal. Soft Stop/Ramp Down time is tied to Soft Start/Ramp Up time selected by SA, SB and SC suffixes and can be combined with Soft Start/Ramp Up only.

Dynamic Brake: It could be used as a modified Stop where the FET switches inside the DP Series SSC are arranged in such a way that they provide a path for the Load Current to keep flowing after the DC power supply has been disconnected. This mode allows for energy stored in some type of loads to be discharged, i.e. back EMF on DC motors. Timing for Dynamic Brake is selected by suffixes B2, B5, B8 and B where the latest will keep the braking or discharging path enabled for as long as FWD and REV Control signals are removed.

Interlock: It will shut down all FET switches inside the DP Series SSC within 0.2 sec after both control signals FWD and REV are applied at the same time. An Interlock condition will trigger a modified Stop such as Soft Stop/Ramp Down or Dynamic Brake whenever an option has been selected.

Control Signals

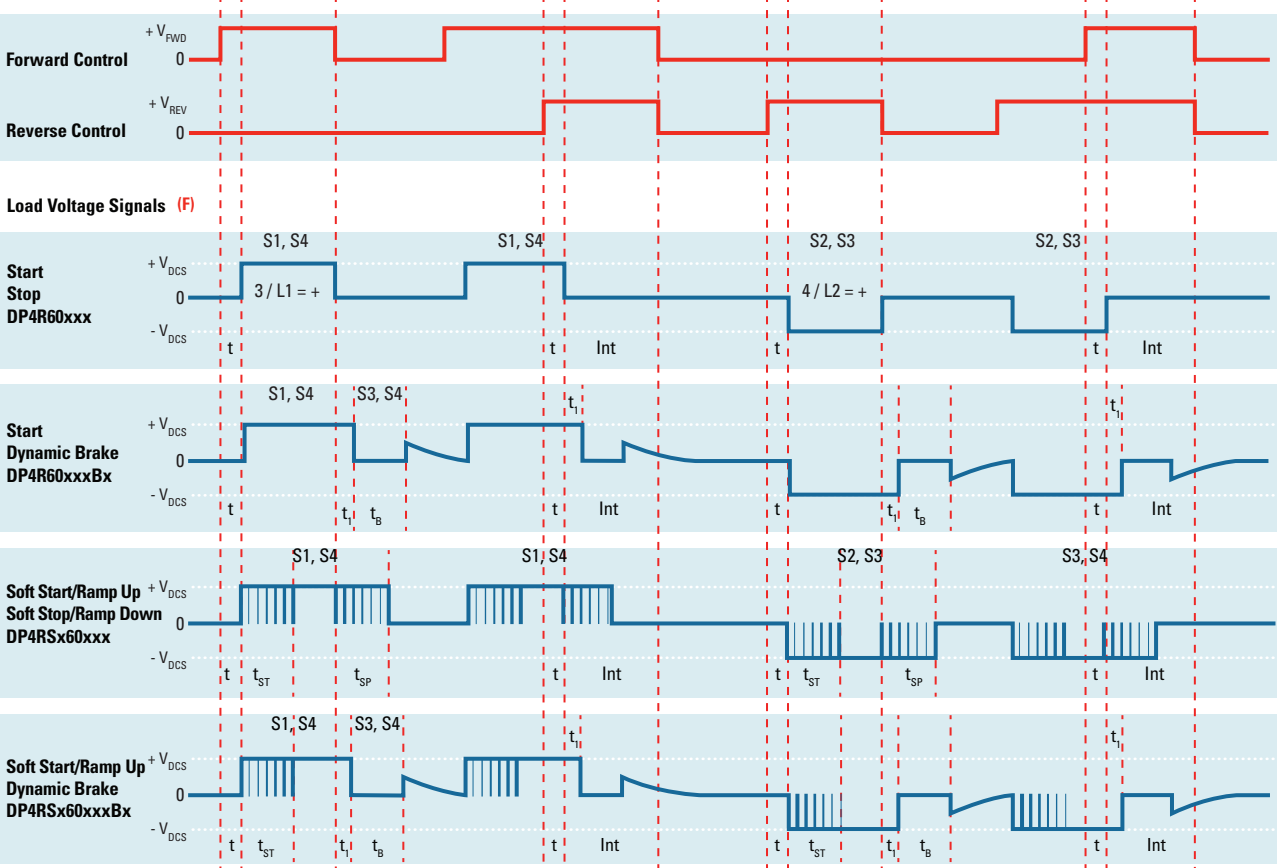

- Int:** Interlock
- t:** Control Signal Validation Delay = 0.2 sec, except for Start / Stop (0.025 sec)
- t_i:** 0.15 sec Break-before-make delay
- t_B:** Dynamic Brake time
 - B2: 0.2 sec
 - B5: 0.5 sec
 - B8: 0.8 sec
 - B: Continuous
- t_{SP}:** Soft Stop/Ramp Down time = t_{ST}
- t_{ST}:** Soft Start/Ramp Up time
 - SA: 0.2 sec
 - SB: 0.5 sec
 - SC: 1 sec
- V_{DCS}:** VDC power supply
- V_{FWD}:** Forward Control Signal
- V_{REV}:** Reverse Control Signal

(F) Load voltage signals shown are typical of a DC motor, behavior may change for other load types.

⚠ DANGER / DANGER / GEFÄHR / PELIGRO / PERICOLO / 危险

<p>HAZARD OF ELECTRIC SHOCK, EXPLOSION OR ARC FLASH</p> <ul style="list-style-type: none"> Turn off power supply before working on this equipment. Failure to follow these instructions will result in death or serious injury. 	<p>RISQUE D'ELECTROCUTION, D'EXPLOSION OU D'ARC ELECTRIQUE</p> <ul style="list-style-type: none"> Coupez l'alimentation avant de travailler sur cet appareil. Le non-respect de ces instructions provoquera la mort ou des blessures graves. 	<p>STROMSCHLAG-, EXPLOSIONS- ODER LICHTBOGENGEFAHR</p> <ul style="list-style-type: none"> Vor dem Arbeiten an dem Gerät dessen Stromversorgung abschalten. Die Nichtbeachtung dieser Anweisungen führt zu Tod oder schwerer Körperverletzung.
<p>RIESGO DE ELECTROCUCIÓN, EXPLOSIÓN O ARCO ELÉCTRICO</p> <ul style="list-style-type: none"> Desconecte toda alimentación antes de realizar el servicio. Si no se siguen estas instrucciones provocará lesiones graves o incluso la muerte. 	<p>RISCHIO DI SCOSSA ELETTRICA, DI ESPLOSIONE O DI OTFALMIA DA FLASH</p> <ul style="list-style-type: none"> Scollagare l'apparecchio dalla presa di corrente prima di qualsiasi intervento. Il mancato rispetto di queste istruzioni provocherà morte o gravi infortuni. 	<p>存在电击、爆炸或电弧闪烁危险</p> <ul style="list-style-type: none"> 在操作此设备之前请先关闭电源。 若不遵守这些说明，可能会导致严重的人身伤害甚至死亡。

⚠ WARNING / AVERTISSEMENT / WARNUNG / ADVERTENCIA / AVVERTENZA / 警告

<p>RISK OF MATERIAL DAMAGE AND HOT ENCLOSURE</p> <ul style="list-style-type: none"> The product's side panels may be hot, allow the product to cool before touching. Follow proper mounting instructions including torque values. Do not allow liquids or foreign objects to enter this product. Failure to follow these instructions can result in serious injury, or equipment damage. 	<p>RISQUE DE DOMMAGE MATERIEL ET DE SURCHAUFFE DU BOITIER</p> <ul style="list-style-type: none"> Les panneaux latéraux du produit peuvent être chauds. Laissez le produit refroidir avant de le toucher. Respecter les consignes de montage, et notamment les couples de serrage. Ne pas laisser pénétrer de liquide ni de corps étrangers à l'intérieur du produit. Le non-respect de cette directive peut entraîner, des lésions corporelles graves ou des dommages matériels. 	<p>GEFAHR VON MATERIALSCHÄDEN UND GEHÄUSEERHITZUNG</p> <ul style="list-style-type: none"> Die Seitenwände können heiß sein. Lassen Sie das Produkt abkühlen, bevor Sie es berühren. Beachten Sie die Montageanweisungen. Führen Sie keine Flüssigkeiten oder Fremdkörper in das Produkt ein. Die Nichtbeachtung dieser Anweisung kann Körperverletzung oder Materialschäden zur Folge haben.
<p>RIESGO DE DAÑOS MATERIALES Y DE SOBRECALENTAMIENTO DE LA UNIDAD</p> <ul style="list-style-type: none"> Los paneles laterales del producto pueden estar calientes. Esperar que el producto se enfríe antes de tocarlo. Respetar las instrucciones de montaje, y en particular los pares de apretado. No dejar que penetren líquidos o cuerpos extraños en el producto. Si no se respetan estas precauciones pueden producirse graves lesiones, daños materiales. 	<p>RISCHIO DI DANNI MATERIALI E D'INVOLUCRO CALDO</p> <ul style="list-style-type: none"> I pannelli laterali dell'apparecchio possono scottare; lasciar quindi raffreddare il prodotto prima di toccarlo. Seguire le istruzioni di montaggio corrette. Non far entrare liquidi o oggetti estranei in questo apparecchio. La mancata osservanza di questa precauzione può causare gravi rischi per l'incolumità personale o danni alle apparecchiature. 	<p>材料损坏和高温外壳的危险性</p> <ul style="list-style-type: none"> 产品的一侧面板可能很热。在其冷却前请不要触碰。 遵照正确的安装说明，包括扭矩值。 请勿让液体及其他异物进入本产品。 如不能正确执行这些操作说明，极有可能造成严重人身伤害或者设备的损坏。

Do not forget to visit us at: www.crydom.com

Copyright © 2011 Crydom Inc. Specifications subject to change without notice.

Downloaded from Elcodis.com electronic components distributor