

LPC1788-32 OEM Board Feature Highlights

The LPC1788-32 OEM Board provides a quick and easy solution for implementing a high-performance ARM Cortex-M3 based design around the LPC1788 from NXP.

- Build around NXP's ARM Cortex-M3 LPC1788 microcontroller with 512Kbyte internal FLASH and 96Kbyte internal SRAM
- 32MByte external SDRAM, via 32-bit databus
- 128 Mbyte NAND FLASH
- 100/10Mbps Ethernet interface based on SMSC LAN8720
- 12.000 MHz and 32.768 kHz crystals for LPC1788
- 32Kbyte I2C E2PROM for storing non-volatile parameters
- Buffered 32-bit data bus
- +3.3V powering
- 200 pos expansion connector (as defined in popular SO-DIMM industry standard), 0.6mm pitch
- Compact design with dimensions: 68 x 55 mm



Support Highlights

- Access to Embedded Artists support page containing
 - Schematics
 - User's Manual
 - Sample software applications
 - OEM Board Integration Guide
- Supported by Developer's Kit, see picture to right
- Volume discount available
- Customization service available for optimized high-volume design



Block Diagram of LPC1788-32 OEM Board

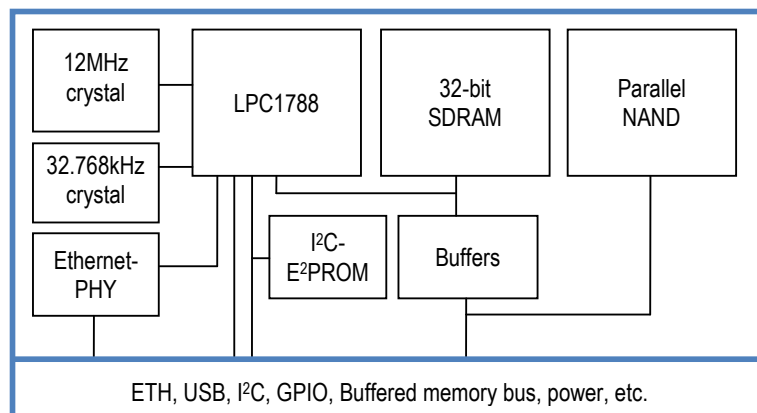

NXP Partner

Embedded Artists is a partner of NXP. Together we give engineers an excellent base to work from when creating advanced embedded systems. We have a close co-operation and know everything there is to know about the NXP processors. Take advantage of our unique knowledge! For further information, please contact: support@EmbeddedArtists.com



Absolute Maximum Ratings

Parameter	Rating
VDD to GND (Supply voltage)	-0.5V to +3.6V
General for Digital/Analog Input/Output Voltage +5V tolerant pins on LPC1788	-0.5V to VDD+0.5V -0.5V to +6.0V (see LPC1788 DS for details)
Storage temperature	-40°C to 100°C

Stress above these limits may cause permanent damage to the board.

Technical Data

Parameter	Min	Typical	Max
Supply voltage (VDD to GND)	3.10V	3.30V	3.50V
Ripple with frequency contents < 100kHz			50mV
Ripple with frequency contents ≥ 100kHz			10mV
Supply current			Max observed
- idle, 32kHz RTC active		TBD ^[2]	
- low-power mode		TBD ^[2]	
- executing from internal flash (100MHz)		TBD ^[2]	
- executing from external sdram (100MHz)		TBD ^[2]	
- Ethernet+usb active		TBD ^[2]	
VBAT current		TBD ^[2]	
Operating temperature ^[1]		TBD ^[2]	
Relative Humidity (RH)			
0°C < T _A ≤ 50°C, non-condensing	5%		80%
50°C < T _A ≤ 60°C, non-condensing	5%		50%
60°C < T _A ≤ 70°C, non-condensing	5%		35%

[1] Extended temperature range can be supplied on request. Subject to minimum order volume.

[2] Will be defined after a characterization process.

Mechanical Dimensions

Board width according to SO-DIMM standard: 67.6 mm.

Board height and depth according to picture below:

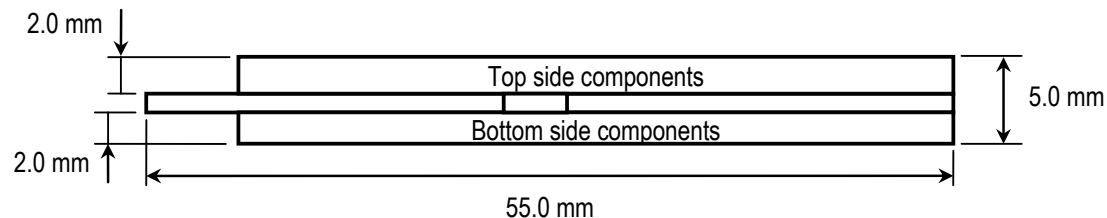

ESD CAUTION

ESD (electrostatic discharge) sensitive device. Charged devices and circuit boards can discharge without detection. Although this product features ESD protection damages may occur on devices subjected to high energy ESD. Therefore, proper ESD precaution should be taken to avoid performance degradation or loss of functionality.



Pin Information

SO-DIMM pins	I/O, Application Details	Connected to
1	A, Ethernet TXP	Ethernet-PHY
2	A, Ethernet RXP	Ethernet-PHY
3	A, Ethernet TXN	Ethernet-PHY
4	A, Ethernet RXP	Ethernet-PHY
5	P, VDD3_3A	
6	P, GND	
7	OD, ETH-LED1	Ethernet-PHY
8	OD, ETH-LED2	Ethernet-PHY
9	P, VBAT-IN	LPC1788, vbat
10	O, RTC-ALARM	LPC1788, rtc-alarm
11	I, RESET-IN	LPC1788, rst-in
12	O, RESET-OUT	LPC1788, rst-out
13	NC	
14	B, GPIO	LPC1788, P5.0
15	O, TCK/SWDCLK	LPC1788, tck/swdclk
16	B, GPIO	LPC1788, P5.4
17	I, TRST	LPC1788, trst
18	B, TMS/SWDIO	LPC1788, tms/swdio
19	I, TDI	LPC1788, tdi
20	O, TDO/SWO	LPC1788, tdo/swo
21	P, V3A	LPC1788, v3a
22	P, VREF	LPC1788, vref
23	P, VSSA	LPC1788, vssa
24	P, GND	
25	B, GPIO	LPC1788, P2.0
26	B, GPIO	LPC1788, P2.1
27	B, GPIO	LPC1788, P2.2
28	B, GPIO	LPC1788, P2.3
29	B, GPIO	LPC1788, P2.4
30	B, GPIO	LPC1788, P2.5
31	B, GPIO	LPC1788, P2.6
32	B, GPIO	LPC1788, P2.7
33	B, GPIO	LPC1788, P2.8
34	B, GPIO	LPC1788, P2.9
35	B, GPIO	LPC1788, P2.10
36	B, GPIO	LPC1788, P2.11
37	P, VCC	
38	P, GND	
39	P, VCC	
40	P, GND	
41	A, USB1-DP	LPC1788, USB-D+1
42	A, USB2-DP	LPC1788, USB-D+2
43	A, USB1-DM	LPC1788, USB-D-1
44	A, USB2-DM	LPC1788, USB-D-2
45	B, GPIO	LPC1788, P2.12
46	B, GPIO	LPC1788, P2.13
47	B, GPIO	LPC1788, P0.0
48	B, GPIO	LPC1788, P0.1
49	B, GPIO	LPC1788, P0.2
50	B, GPIO	LPC1788, P0.3
51	B, GPIO	LPC1788, P0.4
52	B, GPIO	LPC1788, P0.5
53	B, GPIO	LPC1788, P0.6

SO-DIMM pins	I/O, Application Details	Connected to
101	P, GND	
102	P, GND	
103	NC	
104	NC	
105	NC	
106	NC	
107	B, GPIO	LPC1788, P5.4
108	B, GPIO	LPC1788, P5.3
109	B, GPIO	LPC1788, P5.2
110	NC	
111	B, GPIO	LPC1788, P1.16
112	NC	
113	O, Buffered CS1 (internal NAND)	LPC1788, P4.31 via buffer
114	B, GPIO	LPC1788, P4.30
115	B, GPIO	LPC1788, P1.16
116	B, GPIO	LPC1788, P2.14
117	B, GPIO	LPC1788, P2.15
118	B, GPIO	LPC1788, P2.19
119	B, GPIO	LPC1788, P2.21
120	B, GPIO	LPC1788, P2.22
121	B, GPIO	LPC1788, P2.23
122	B, GPIO	LPC1788, P2.25
123	B, GPIO	LPC1788, P2.26
124	B, GPIO	LPC1788, P2.27
125	NC	
126	NC	
127	NC	
128	NC	
129	P, GND	
130	P, GND	
131	O, Buffered Address bus 15	LPC1788, P4.15 via buffer
132	O, Buffered CS2	LPC1788, P2.14 via buffer
133	O, Buffered Address bus 14	LPC1788, P4.14 via buffer
134	O, Buffered CS0	LPC1788, P4.30 via buffer
135	O, Buffered Address bus 13	LPC1788, P4.13 via buffer
136	O, Buffered BLS3	LPC1788, P4.29 via buffer
137	O, Buffered Address bus 12	LPC1788, P4.12 via buffer
138	O, Buffered BLS2	LPC1788, P4.28 via buffer
139	O, Buffered Address bus 11	LPC1788, P4.11 via buffer
140	O, Buffered BLS1	LPC1788, P4.27 via buffer
141	O, Buffered Address bus 10	LPC1788, P4.10 via buffer
142	O, Buffered BLS0	LPC1788, P4.26 via buffer
143	O, Buffered Address bus 9	LPC1788, P4.9 via buffer
144	O, Buffered WE	LPC1788, P4.25 via buffer
145	O, Buffered Address bus 8	LPC1788, P4.8 via buffer
146	O, Buffered OE	LPC1788, P4.24 via buffer
147	O, Buffer Address bus 7	LPC1788, P4.7 via buffer
148	O, Buffer Address bus 23	LPC1788, P4.23 via buffer
149	O, Buffer Address bus 6	LPC1788, P4.6 via buffer
150	O, Buffer Address bus 22	LPC1788, P4.22 via buffer
151	O, Buffer Address bus 5	LPC1788, P4.5 via buffer
152	O, Buffer Address bus 21	LPC1788, P4.21 via buffer
153	O, Buffer Address bus 4	LPC1788, P4.4 via buffer

54	B, GPIO	LPC1788, P0.7
55	B, GPIO	LPC1788, P0.8
56	B, GPIO	LPC1788, P0.9
57	B, GPIO	LPC1788, P0.10
58	B, GPIO	LPC1788, P0.11
59	B, GPIO	LPC1788, P0.12
60	B, GPIO	LPC1788, P0.13
61	B, GPIO	LPC1788, P0.14
62	B, GPIO	LPC1788, P0.15
63	B, GPIO	LPC1788, P0.16
64	B, GPIO	LPC1788, P0.17
65	B, GPIO	LPC1788, P0.18
66	B, GPIO	LPC1788, P0.19
67	B, GPIO	LPC1788, P0.20
68	B, GPIO	LPC1788, P0.21
69	B, GPIO	LPC1788, P0.22
70	B, GPIO	LPC1788, P0.23
71	B, GPIO	LPC1788, P0.24
72	B, GPIO	LPC1788, P0.25
73	B, GPIO	LPC1788, P0.26
74	B, I2C-SDA	LPC1788, P0.27
75	B, I2C-SCL	LPC1788, P0.28
76	P, GND	
77	P, GND	
78	B, GPIO	LPC1788, P1.2
79	B, GPIO	LPC1788, P1.3
80	B, GPIO	LPC1788, P1.5
81	B, GPIO	LPC1788, P1.6
82	B, GPIO	LPC1788, P1.7
83	B, GPIO	LPC1788, P1.11
84	B, GPIO	LPC1788, P1.12
85	B, GPIO	LPC1788, P1.13
86	B, GPIO	LPC1788, P1.18
87	B, GPIO	LPC1788, P1.19
88	B, GPIO	LPC1788, P1.20
89	B, GPIO	LPC1788, P1.21
90	B, GPIO	LPC1788, P1.22
91	B, GPIO	LPC1788, P1.23
92	B, GPIO	LPC1788, P1.24
93	B, GPIO	LPC1788, P1.25
94	B, GPIO	LPC1788, P1.26
95	B, GPIO	LPC1788, P1.27
96	B, GPIO	LPC1788, P1.28
97	B, GPIO	LPC1788, P1.29
98	B, GPIO	LPC1788, P1.30
99	B, GPIO	LPC1788, P1.31
100	OD, NandFlashRdy	Internal NAND flash

I/O legend

O: output

I: input

B: Bidirectional

P: Power

A: Analog

154	O, Buffer Address bus 20	LPC1788, P4.20 via buffer
155	O, Buffer Address bus 3	LPC1788, P4.3 via buffer
156	O, Buffer Address bus 19	LPC1788, P4.19 via buffer
157	O, Buffer Address bus 2	LPC1788, P4.2 via buffer
158	O, Buffer Address bus 18	LPC1788, P4.18 via buffer
159	O, Buffer Address bus 1	LPC1788, P4.1 via buffer
160	O, Buffer Address bus 17	LPC1788, P4.17 via buffer
161	O, Buffer Address bus 0	LPC1788, P4.0 via buffer
162	O, Buffer Address bus 16	LPC1788, P4.16 via buffer
163	O, Buffered CS3	LPC1788, P2.15 via buffer
164	I, ABUF_EN	Connected to GND on board
165	P, Buffer-VCC	
166	P, GND	
167	B, Buffer Data bus 15	LPC1788, P3.15 via buffer
168	B, Buffer Data bus 31	LPC1788, P3.31 via buffer
169	B, Buffer Data bus 14	LPC1788, P3.14 via buffer
170	B, Buffer Data bus 30	LPC1788, P3.30 via buffer
171	B, Buffer Data bus 13	LPC1788, P3.13 via buffer
172	B, Buffer Data bus 29	LPC1788, P3.29 via buffer
173	B, Buffer Data bus 12	LPC1788, P3.12 via buffer
174	B, Buffer Data bus 28	LPC1788, P3.28 via buffer
175	B, Buffer Data bus 11	LPC1788, P3.11 via buffer
176	B, Buffer Data bus 27	LPC1788, P3.27 via buffer
177	B, Buffer Data bus 10	LPC1788, P3.10 via buffer
178	B, Buffer Data bus 26	LPC1788, P3.26 via buffer
179	B, Buffer Data bus 9	LPC1788, P3.9 via buffer
180	B, Buffer Data bus 25	LPC1788, P3.25 via buffer
181	B, Buffer Data bus 8	LPC1788, P3.8 via buffer
182	B, Buffer Data bus 24	LPC1788, P3.24 via buffer
183	B, Buffer Data bus 7	LPC1788, P3.7 via buffer
184	B, Buffer Data bus 23	LPC1788, P3.23 via buffer
185	B, Buffer Data bus 6	LPC1788, P3.6 via buffer
186	B, Buffer Data bus 22	LPC1788, P3.22 via buffer
187	B, Buffer Data bus 5	LPC1788, P3.5 via buffer
188	B, Buffer Data bus 21	LPC1788, P3.21 via buffer
189	B, Buffer Data bus 4	LPC1788, P3.4 via buffer
190	B, Buffer Data bus 20	LPC1788, P3.20 via buffer
191	B, Buffer Data bus 3	LPC1788, P3.3 via buffer
192	B, Buffer Data bus 19	LPC1788, P3.19 via buffer
193	B, Buffer Data bus 2	LPC1788, P3.2 via buffer
194	B, Buffer Data bus 18	LPC1788, P3.18 via buffer
195	B, Buffer Data bus 1	LPC1788, P3.1 via buffer
196	B, Buffer Data bus 17	LPC1788, P3.17 via buffer
197	B, Buffer Data bus 0	LPC1788, P3.0 via buffer
198	B, Buffer Data bus 16	LPC1788, P3.16 via buffer
199	P, Buffer-VCC	
200	P, GND	

OD: Open-drain output

GPIO: General purpose I/O

GPI: General purpose input

GPO: General purpose output

Disclaimers

Embedded Artists reserves the right to make changes to information published in this document, including without limitation specifications and product descriptions, at any time and without notice. This document supersedes and replaces all information supplied prior to the publication hereof.

Customer is responsible for the design and operation of their applications and products using Embedded Artists' products, and Embedded Artists accepts no liability for any assistance with applications or customer product design. It is customer's sole responsibility to determine whether the Embedded Artists' product is suitable and fit for the customer's applications and products planned, as well as for the planned application and use of customer's third party customer(s). Customers should provide appropriate design and operating safeguards to minimize the risks associated with their applications and products.

Embedded Artists does not accept any liability related to any default, damage, costs or problem which is based on any weakness or default in the customer's applications or products, or the application or use by customer's third party customer(s). Customer is responsible for doing all necessary testing for the customer's applications and products using Embedded Artists' products in order to avoid a default of the applications and the products or of the application or use by customer's third party customer(s). Embedded Artists does not accept any liability in this respect.

Embedded Artists does not accept any liability for erratas on individual components.

All Embedded Artists' products are sold pursuant to Embedded Artists' terms and conditions of sale:

http://www.embeddedartists.com/shop/General_Terms_and_Conditions.pdf

No license, express or implied, by estoppel or otherwise, to any intellectual property rights is granted under this document. If any part of this document refers to any third party products or services it shall not be deemed a license grant by Embedded Artists for the use of such third party products or services, or any intellectual property contained therein or considered as a warranty covering the use in any manner whatsoever of such third party products or services or any intellectual property contained therein.

UNLESS OTHERWISE SET FORTH IN EMBEDDED ARTISTS' TERMS AND CONDITIONS OF SALE EMBEDDED ARTISTS DISCLAIMS ANY EXPRESS OR IMPLIED WARRANTY WITH RESPECT TO THE USE AND/OR SALE OF EMBEDDED ARTISTS PRODUCTS INCLUDING WITHOUT LIMITATION IMPLIED WARRANTIES OF MERCHANTABILITY, FITNESS FOR A PARTICULAR PURPOSE (AND THEIR EQUIVALENTS UNDER THE LAWS OF ANY JURISDICTION), OR INFRINGEMENT OF ANY PATENT, COPYRIGHT OR OTHER INTELLECTUAL PROPERTY RIGHT.

UNLESS EXPRESSLY APPROVED IN WRITING BY THE CEO OF EMBEDDED ARTISTS, PRODUCTS ARE NOT RECOMMENDED, AUTHORIZED OR WARRANTED FOR USE IN MILITARY, AIR CRAFT, SPACE, NUCLEAR, LIFE SAVING, OR LIFE SUSTAINING APPLICATIONS, NOR IN PRODUCTS OR SYSTEMS WHERE FAILURE OR MALFUNCTION MAY RESULT IN PERSONAL INJURY, DEATH, OR SEVERE PROPERTY OR ENVIRONMENTAL DAMAGE.

Resale of Embedded Artists' products with provisions different from the statements and/or technical features set forth in this document shall immediately void any warranty granted by Embedded Artists for the Embedded Artists' product or service described herein and shall not create or extend in any manner whatsoever, any liability of Embedded Artists.

This document as well as the item(s) described herein may be subject to export control regulations. Export might require a prior authorization from national authorities.

Definition of Document Status

Preliminary – The document is a draft version only. The content is still under internal review and subject to formal approval, which may result in modifications or additions. Embedded Artists does not give any representations or warranties as to the accuracy or completeness of information included herein and shall have no liability for the consequences of use of such information. The document is in this state until the product has passed Embedded Artists product qualification tests.

Approved – The information and data provided define the specification of the product as agreed between Embedded Artists and its customer, unless Embedded Artists and customer have explicitly agreed otherwise in writing.