

LTM8022

36V, 1A Step-Down μ Module Regulator

DESCRIPTION

Demonstration circuit 1261A features the LTM[®]8022 step-down μ Module[®] regulator delivering a 3.3V output from a 4.5V to 36V input supply. As a step-down converter, the LTM8022 requires a minimum amount of headroom to keep the output in regulation. The device may be synchronized to an external clock or allowed to enter low ripple Burst Mode[®] operation at light load conditions by applying the appropriate signal to the SYNC pin. Current sharing with another LTM8022 is enabled by tying the VIN, VOUT and SHARE pins together to support higher output loads.

The LTM8022 data sheet must be read in conjunction with demo manual prior to working on or modifying demo circuit DC1261A.

Design files for this circuit board are available at <http://www.linear.com/demo>

LT, LT, LTC, LTM, μ Module, Burst Mode, Linear Technology and the Linear logo are registered trademarks of Linear Technology Corporation. All other trademarks are the property of their respective owners.

PERFORMANCE SUMMARY (T_A = 25°C)

PARAMETER	CONDITION	VALUE
Input Voltage Range		4.5V to 36V
Output Voltage, V _{OUT}		3.3V \pm 3%
Maximum Output Current		1A
Typical Switching Frequency		600kHz

BOARD PHOTO

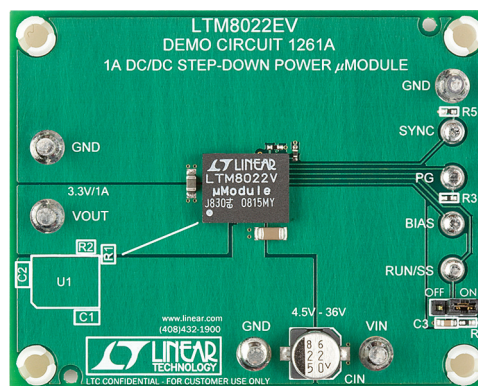

QUICK START PROCEDURE

Demonstration circuit 1261A is an easy way to evaluate the performance of the LTM8022. Refer to Figure 1 for proper measurement equipment setup and follow the procedure below:

Note: When measuring the input or output voltage ripple, care must be taken to avoid a long ground lead on the oscilloscope probe. Measure the input or output voltage ripple by touching the probe tip directly across the VIN or VOUT and GND terminals. See Figure 2 for proper scope probe technique.

1. Place JP1 on the ON position.
2. With power off, preset the input supply within the operating range of the LTM8022 then connect the input power supply to VIN and GND.

3. Turn on the input power supply.

Note: Make sure that the input voltage does not exceed the maximum input voltage.

4. Check for the proper output voltage.

Note: If there is no output, temporarily disconnect the load to make sure that the load is not set too high.

5. Once the proper output voltage are established, adjust the load within the operating range and observe the output voltage regulation, ripple voltage, efficiency and other parameters.

QUICK START PROCEDURE

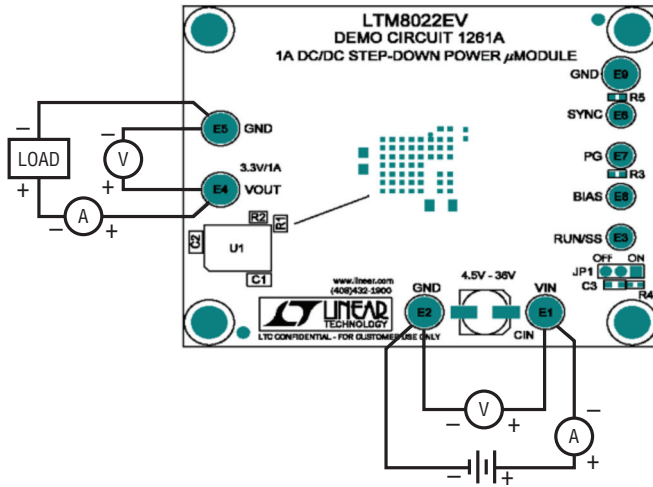

Figure 1. Proper Measurement Equipment Setup

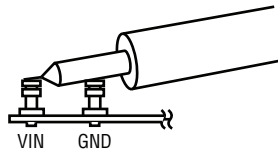

Figure 2. Measuring Input or Output Ripple

DEMO MANUAL DC1261A

PARTS LIST

ITEM	QTY	REFERENCE	DESCRIPTION	MANUFACTURER/PART NUMBER
Required Circuit Components				
1	1	C1	CAP, 1206 2.2 μ F 10% 50V X7R	MURATA GCM31CR71H225KA55L
2	1	C2	CAP, 0805 22 μ F 10% 6.3V X5R	TAIYO YUDEN JMK212BJ226KG-T
3	1	R1	RES, 0402 154k 1% 1/16W	VISHAY CRCW0402154KFKEA
4	1	R2	RES, 0402 56.2k 1% 1/16W	VISHAY CRCW040256K2FKED
5	1	U1	IC, MODULE	LINEAR TECH. LTM8022EV
Additional Demo Board Circuit Components				
1	1	CIN	CAP, 22 μ F 20% 50V ALUM	SANYO 50CE22BS
2	1	C3	CAP, 0603 0.1 μ F 10% 50V X7R	TDK C1608X7R1H104K
3	2	R4, R3	RES, 0402 100k 1% 1/16W	VISHAY CRCW0402100KFKEA
4	1	R5	RES, 0402 10k 5% 1/16W	VISHAY CRCW040210K0JNED
Hardware For Demo Board Only				
1	5	E1, E2, E4, E5, E9	TURRET	MILL-MAX 2501-2-00-80-00-00-07-0
2	4	E3, E6, E7, E8	TURRET	MILL-MAX 2308-2-00-80-00-00-07-0
3	1	JP1	HEADER, 3-PIN, 2mm	SAMTEC TMM-103-02-L-S
4	1	XJP1	SHUNT, 2mm	SAMTEC 2SN-BK-G
5	4		STANDOFF, SNAP ON	KEYSTONE_8831

SCHEMATIC DIAGRAM

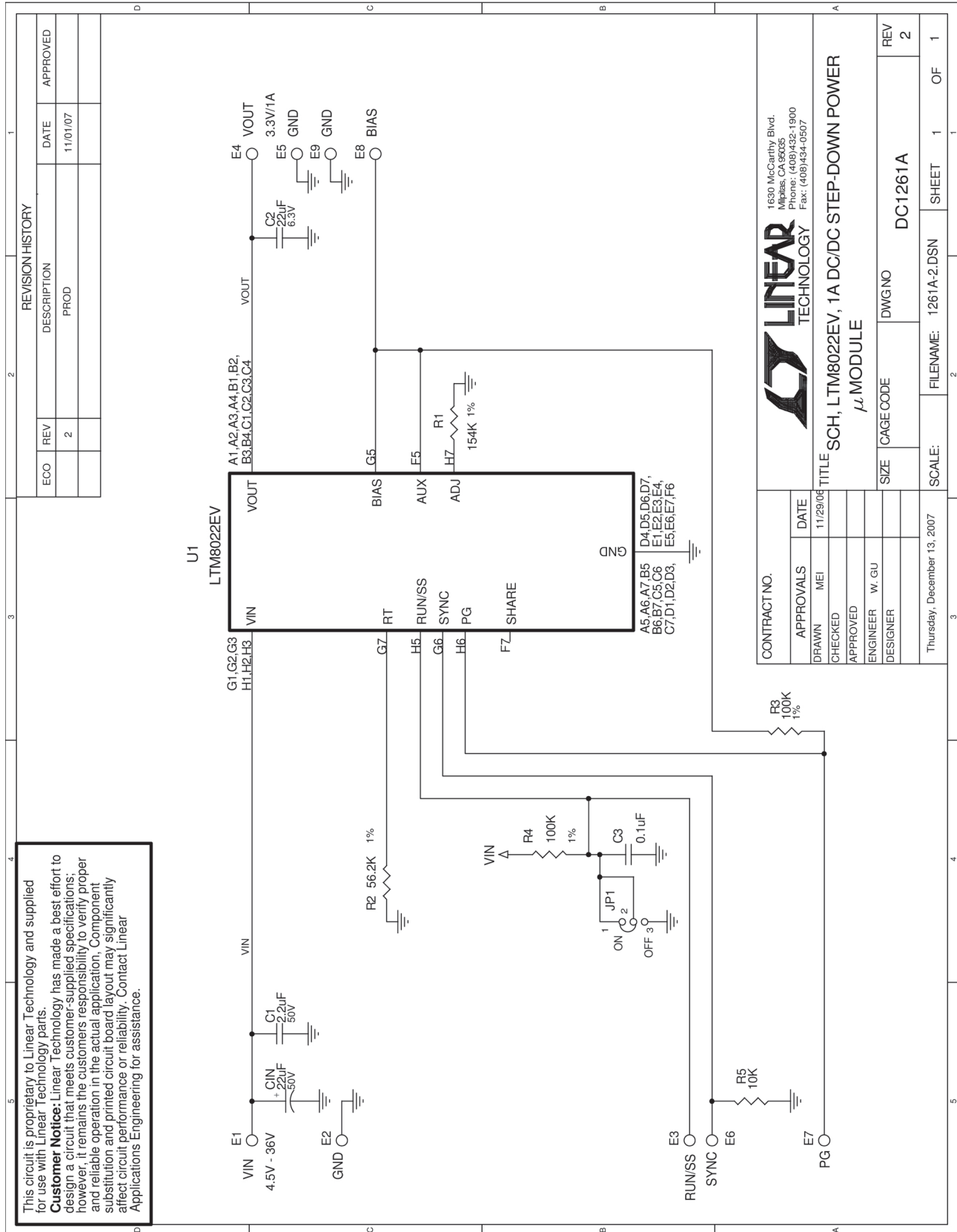

DEMO MANUAL DC1261A

DEMONSTRATION BOARD IMPORTANT NOTICE

Linear Technology Corporation (LTC) provides the enclosed product(s) under the following **AS IS** conditions:

This demonstration board (DEMO BOARD) kit being sold or provided by Linear Technology is intended for use for **ENGINEERING DEVELOPMENT OR EVALUATION PURPOSES ONLY** and is not provided by LTC for commercial use. As such, the DEMO BOARD herein may not be complete in terms of required design-, marketing-, and/or manufacturing-related protective considerations, including but not limited to product safety measures typically found in finished commercial goods. As a prototype, this product does not fall within the scope of the European Union directive on electromagnetic compatibility and therefore may or may not meet the technical requirements of the directive, or other regulations.

If this evaluation kit does not meet the specifications recited in the DEMO BOARD manual the kit may be returned within 30 days from the date of delivery for a full refund. **THE FOREGOING WARRANTY IS THE EXCLUSIVE WARRANTY MADE BY THE SELLER TO BUYER AND IS IN LIEU OF ALL OTHER WARRANTIES, EXPRESSED, IMPLIED, OR STATUTORY, INCLUDING ANY WARRANTY OF MERCHANTABILITY OR FITNESS FOR ANY PARTICULAR PURPOSE. EXCEPT TO THE EXTENT OF THIS INDEMNITY, NEITHER PARTY SHALL BE LIABLE TO THE OTHER FOR ANY INDIRECT, SPECIAL, INCIDENTAL, OR CONSEQUENTIAL DAMAGES.**

The user assumes all responsibility and liability for proper and safe handling of the goods. Further, the user releases LTC from all claims arising from the handling or use of the goods. Due to the open construction of the product, it is the user's responsibility to take any and all appropriate precautions with regard to electrostatic discharge. Also be aware that the products herein may not be regulatory compliant or agency certified (FCC, UL, CE, etc.).

No License is granted under any patent right or other intellectual property whatsoever. **LTC assumes no liability for applications assistance, customer product design, software performance, or infringement of patents or any other intellectual property rights of any kind.**

LTC currently services a variety of customers for products around the world, and therefore this transaction **is not exclusive**.

Please read the DEMO BOARD manual prior to handling the product. Persons handling this product must have electronics training and observe good laboratory practice standards. **Common sense is encouraged.**

This notice contains important safety information about temperatures and voltages. For further safety concerns, please contact a LTC application engineer.

Mailing Address:

Linear Technology
1630 McCarthy Blvd.
Milpitas, CA 95035

Copyright © 2004, Linear Technology Corporation