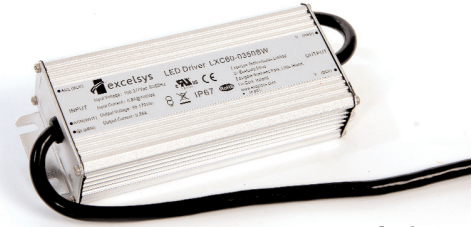

LXD85 series

LED Power Supply

Dimmable LED Power Supplies

**LED Power
85W**

LED POWER
next generation power
source

FEATURES

- High Efficiency (up to 91%)
- Dimming Control
- UL1310 Class 2
- Active PFC (Typical 0.99)
- IP67 Waterproof
- OVP, SCP, OTP
- -35 to 60°C deg operation
- Universal Input 90-305VAC
- UL8750 compliant
- EN61347-1, -2-13 compliant

The LXD85 series of Class 2 dimmable LED power supplies from Excelsys Technologies can deliver up to 85W of output power in an extremely compact package size.

The LXD85 series of constant current power supplies provides up to 2800mA of output current and 243V output voltage solutions for specific LED requirements. With industry leading efficiencies, and an extensive protection feature set, the LXD85 series provides high reliability and high performance in a compact package.

Model Number	Output Voltage	Output Current	Input Voltage	OVP Latching max	Efficiency
LXD85-0350SW	122-243V	350mA	90-305VAC	340V	91.0%
LXD85-0450SW	95-189V	450mA	90-305VAC	264V	91.0%
LXD85-0700SW	61-121V	700mA	90-305VAC	170V	90.0%
LXD85-1050SW	41-81V	1050mA	90-305VAC	113V	90.0%
LXD85-1400SW	31-61V	1400mA	90-305VAC	85V	90.0%
LXD85-1750SW ^(H)	25-49V	1750mA	90-305VAC	68V	90.0%
LXD85-2000SW ^(H)	22-43V	2000mA	90-305VAC	60V	90.0%
LXD85-2450SW ^(H)	18-35V	2450mA	90-305VAC	49V	89.0%
LXD85-2800SW ^(H)	16-30V	2800mA	90-305VAC	43V	89.0%

Input Specifications

Parameter	Conditions/Description	Min	Nom	Max	Units
Input Voltage Range	Universal Input	90		305	VAC
Input Frequency Range		47		63	Hz
Input Current	100VAC in, 85W output			1.1A	
Leakage Current	277VAC in, 50Hz			1.0	mA
Inrush Current	230VAC in, 25°C, Cold Start			50	A
Power Factor	220VAC, 110VAC	0.95		0.99	

Output Specifications

Parameter	Conditions/Description	Min	Nom	Max	Units
Line Regulation				±2	%
Load Regulation				±3	%
Voltage Range	See table of outputs				
Output Current Accuracy	% of Iout			±5	%
Ripple and Noise	20MHz Bandwidth. See Note H			3.0	% pk-pk
Overshoot				10	%
Turn-on Delay	Measured at 220VAC and full load		0.6	1	s
Short Circuit Protection	Auto Recovery				
Over Voltage Protection	Latching. See individual models OVP levels				
Over Temp Protection	Latching Internal component temperature		120		°C

General Specifications

Parameter	Conditions/Description	Min	Nom	Max	Units
Isolation Voltage	Input to Output See Note B	3750			VAC
	Input to Chassis	1500			VAC
Efficiency	See individual models		90.5		%
Safety Agency Approvals	UL8750, EN61347-1, -2-13				
No load Power Dissipation	Measured at 230 VAC		1.0		W
MTBF	MIL-HDBK-217F, 110VAC input, 80% Load, 25°C		300,000		Hours
Lifetime	45°C, 110VAC Input, 80% Load		63,000		Hours
Weight			770		g
Operating Temperature	Maximum Case Temperature Tcase =89°C	-35		+60	°C
Storage Temperature		-40		+85	°C
Relative Humidity	Non-condensing (operating)	10		100	%RH



Europe/Asia

Excelsys Technologies Ltd
27 Eastgate Drive
Eastgate Business Park
Little Island, Cork, Ireland
IRELAND

t: +353 21 4354716

f: +353 21 4354864

e: sales@excelsys.com

North America

Excelsys Technologies
519 Interstate 30, #309
Rockwall, TX 75087
USA

t: (972) 771 4544

f: (972) 421 1805

e: salesusa@excelsys.com

EMC				
Parameter	Standard		Level	Units
Emissions				
Conducted	EN55015		Compliant	
Radiated	EN55015		Compliant	
Harmonic Distortion	EN61000-3-2		Compliant	
Flicker and Fluctuation	EN61000-3-3		Compliant	
Immunity				
ESD	EN61000-4-2		Level 4	
Radiated RFI	EN61000-4-3		Level 3	
Fast Transients - burst	EN61000-4-4		Level 4	
Surge Immunity	EN61000-4-5		Level 4	
Conducted RFI	EN61000-4-6		Compliant	
Power Freq Magnetic Field	EN61000-4-8		Compliant	
Voltage Dips	EN61000-4-11			

Dimming Control					
Parameter		Min	Nom	Max	Units
Control Voltage (1-10V input)	Voltage applied on 1-10V input wire	-2		12	V
Source Current (1-10V input)	Source current on 1-10V input wire	0		0.5	mA

- Note A. If dimming function is not required, dimming wires are to be floating
 Note B. Primary to Secondary Isolation test not to be carried on power supply.
 Note C. Load Voltage must be maintained above minimum voltage. See models for voltage range.
 Note D. Dimming range is 10%-100%
 Note E. See graphs for Dimming control. If Dimming Signal Voltage is 0-1V, output current is 10% rated current. If Dimming Signal Voltage is 9.5-10V, output current is 100% rated current
 Note F. See Dimming Implementation diagrams for various dimming methods.
 Note G. Do not connect GND of Dimming cable to Output.
 Note H. Class 2 (USR and CNR) except for LXD85-1750SW and LXD85-2000SW which are Class 2 US only.

INPUT / OUTPUT WIRING

INPUT CABLE

SJTW 18AWG 3C
 Black (L), White (N), Green (G) 650±20mm

OUTPUT CABLE

SJTW 18AWG 2C
 Black (-V) and Red (+V) 220±20mm

DIMMING CABLE

SJTW 22AWG 2C
 Purple (1-10V), Grey (GND)

MECHANICAL SPECIFICATIONS

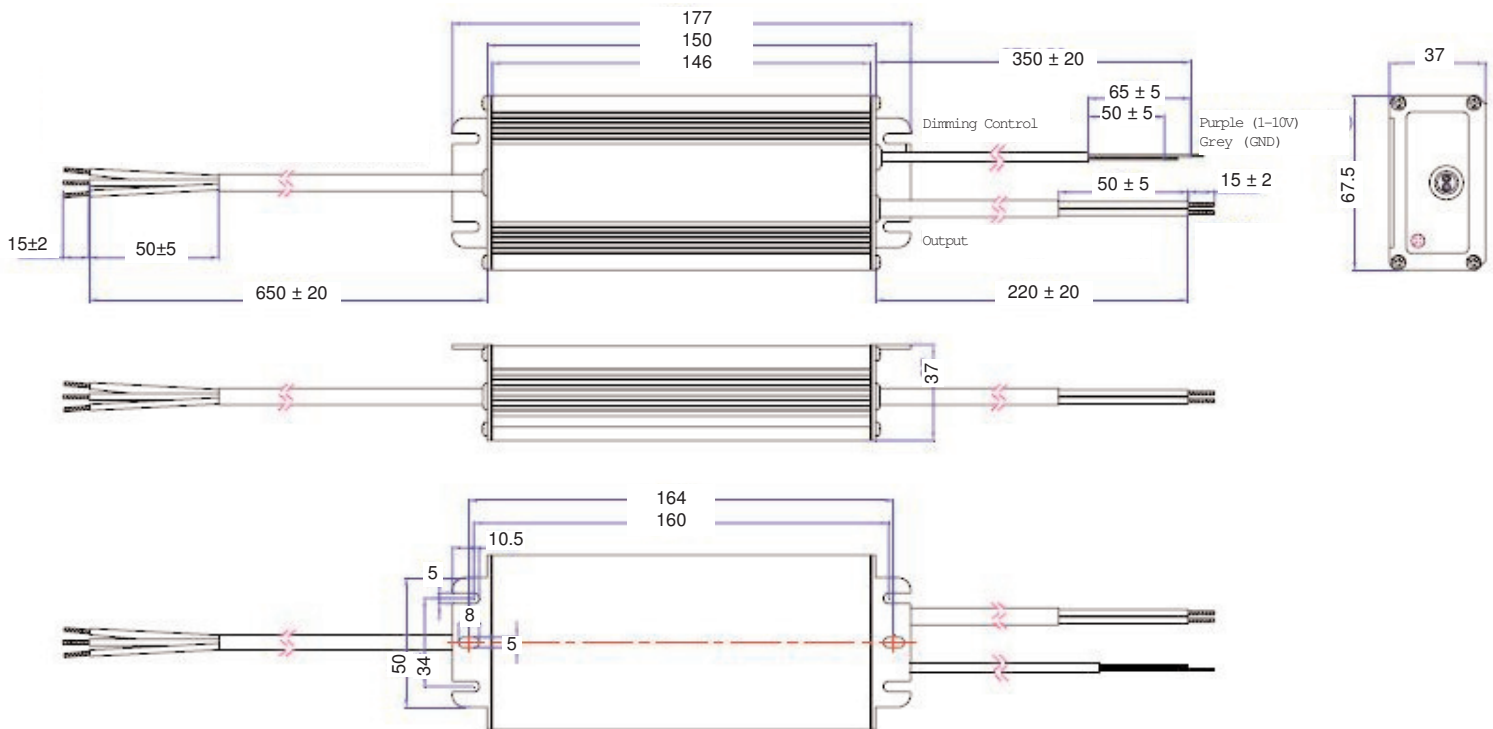

Europe/Asia

Excelsys Technologies Ltd t: +353 21 4354716
 27 Eastgate Drive f: +353 21 4354864
 Eastgate Business Park e: sales@excelsys.com
 Little Island, Cork, Ireland
 IRELAND

North America

Excelsys Technologies t: (972) 771 4544
 519 Interstate 30, #309 f: (972) 421 1805
 Rockwall, TX 75087 e: salesusa@excelsys.com
 USA

Dimming Implementation Diagrams

LED Power
85W

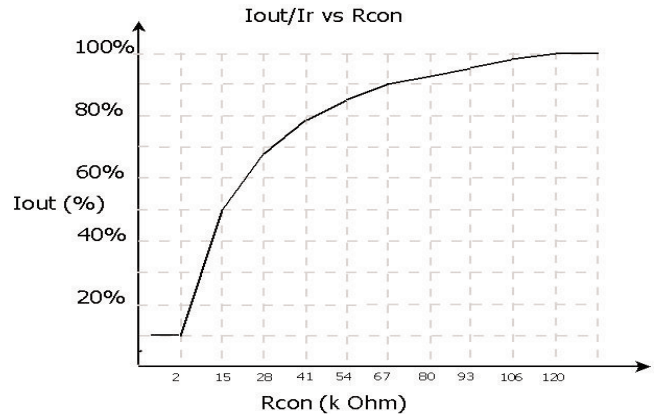
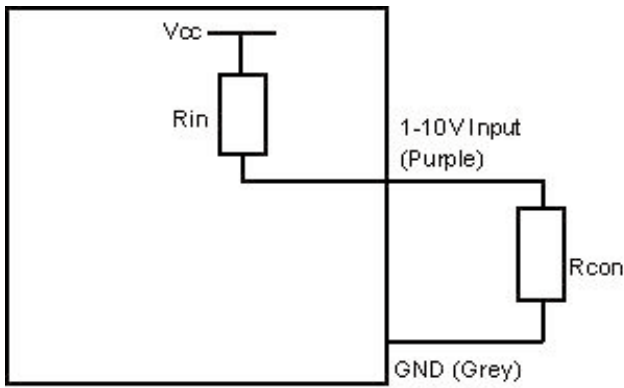
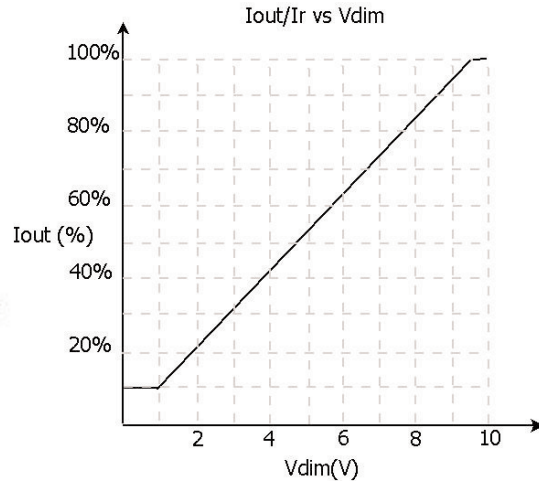
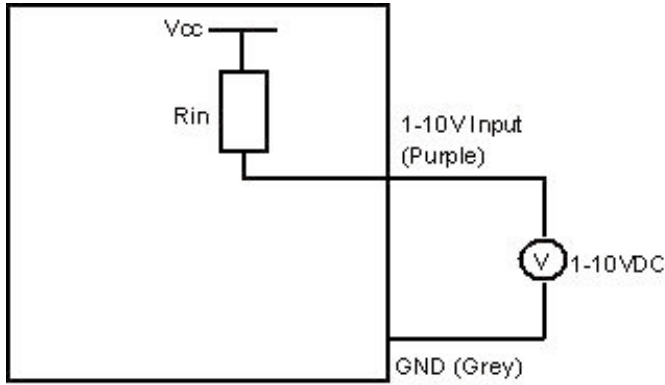

Specifications are subject to change without notice
LXD85 Datasheet Release 18 March 2011



Europe/Asia		North America	
Excelsys Technologies Ltd	t: +353 21 4354716	Excelsys Technologies	t: (972) 771 4544
27 Eastgate Drive	f: +353 21 4354864	519 Interstate 30, #309	f: (972) 421 1805
Eastgate Business Park	e: sales@excelsys.com	Rockwall, TX 75087	e: salesusa@excelsys.com
Little Island, Cork, Ireland		USA	
IRELAND			