

Engineering Sample Specifications

CUSTOMER : Philips Lighting
DESCRIPTION : LED Cooling Module
DIMENSIONS : $\phi 86 \times 52.4$ mm
MODEL : TA004-10003
P/N :

ENGINEER	Hour Alankuo	APPROVAL	Terry
SSR NO.	S1001199-0	IS SUE DATE	11. 18. 2010
建準電機工業股份有限公司 SUNONWEALTH ELECTRIC MACHINE INDUSTRY CO., LTD TEL:886-7-7163069(41 LINES) FAX:886-7-7163086/87/88 WEB PAGE : http : //www.sunon.com.tw			

1. Construction

MOTOR DESIGN	DC Brushless motor design
BEARING SYSTEM	Vapo bearing system
DIMENSIONS	See Page 3
MATERIALS OF HOUSING	Thermoplastic PBT of UL 94V-0
MATERIALS OF FAN BLADE	Thermoplastic PBT of UL 94V-0
DIRECTION OF ROTATION	Counter-clockwise viewed from front of fan blade
Tolerance	±20% on rated power and current.
WEIGHT	232 g

2. Rating

RATED VOLTAGE	12 VDC
STARTING VOLTAGE	6.5 VDC (25 deg. C POWER ON/OFF)
OPERATING VOLTAGE RANGE	6.5-13.8 VDC
RATED CURRENT	34 mA
RATED POWER CONSUMPTION	0.41 WATTS
ACOUSTIC NOISE	16.6 dB(A) @1M
RATED SPEED	2200 RPM ± 10% (Fan+Sink)
OPERATING TEMPERATURE RANGE	-10 to + 70 deg.C
STORAGE TEMPERATURE RANGE	-40 to + 70 deg.C
THERMAL RESISTANCE	0.52 °C/Watts

3. Dimensions

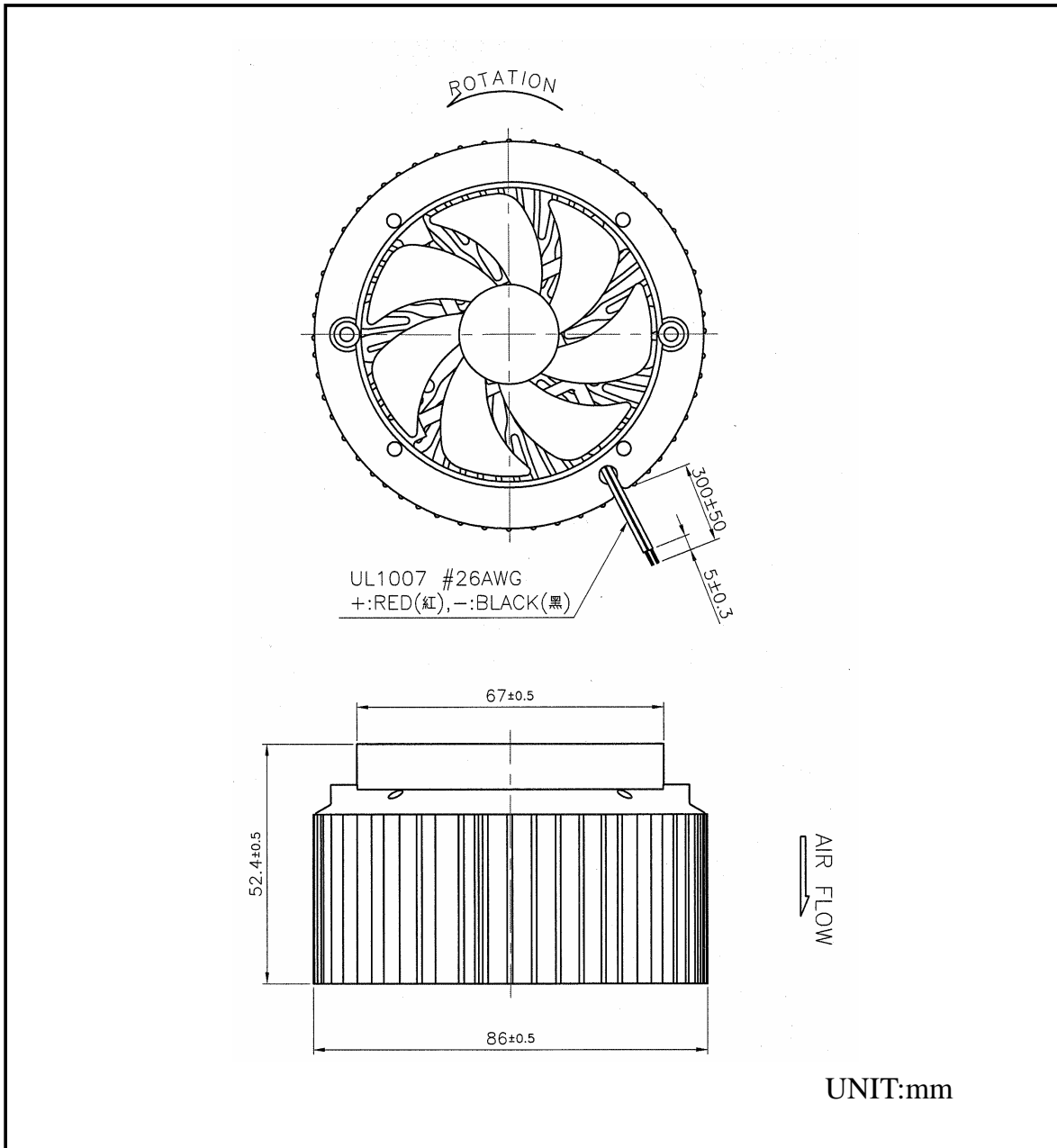

3-1. Dimensions

