

DDR2 SDRAM VLP RDIMM

MT18HVF12872PZ – 1GB

MT18HVF25672PZ – 2GB

MT18HVF51272PZ – 4GB

Features

- 240-pin, registered very low profile, dual in-line memory module, ATCA form factor
- Fast data transfer rates: PC2-3200, PC2-4200, PC2-5300, or PC2-6400
- 1GB (128 Meg x 72), 2GB (256 Meg x 72), or 4GB (512 Meg x 72)
- Supports ECC error detection and correction
- $V_{DD} = V_{DDQ} = 1.8V$
- $V_{DDSPD} = 1.7-3.6V$
- JEDEC-standard 1.8V I/O (SSTL_18-compatible)
- Differential data strobe (DQS, DQS#) option
- 4n-bit prefetch architecture
- Single rank
- Multiple internal device banks for concurrent operation
- Programmable CAS latency (CL)
- Posted CAS additive latency (AL)
- WRITE latency = READ latency - 1 t_{CK}
- Programmable burst lengths (BL): 4 or 8
- Adjustable data-output drive strength
- 64ms, 8192-cycle refresh
- On-die termination (ODT)
- Serial presence-detect (SPD) with EEPROM
- Gold edge contacts
- Halogen-free

Figure 1: 240-Pin VLP RDIMM (ATCA Form Factor)

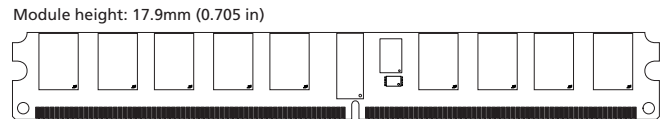

Options

- Parity
- Operating temperature¹
 - Commercial (0°C ≤ T_A ≤ +70°C)
- Package
 - 240-pin DIMM (halogen-free)
- Frequency/CL²
 - 2.5ns @ CL = 5 (DDR2-800)
 - 2.5ns @ CL = 6 (DDR2-800)
 - 3.0ns @ CL = 5 (DDR2-667)

Marking

- P
- None
- Z
- 80E
- 800
- 667

- Notes:
1. Contact Micron for industrial temperature module offerings.
 2. CL = CAS (READ) latency; registered mode will add one clock cycle to CL.

Table 1: Key Timing Parameters

Speed Grade	Industry Nomenclature	Data Rate (MT/s)				t _{RCD} (ns)	t _{RP} (ns)	t _{RC} (ns)
		CL = 6	CL = 5	CL = 4	CL = 3			
-80E	PC2-6400	800	800	533	400	12.5	12.5	55
-800	PC2-6400	800	667	533	400	15	15	55
-667	PC2-5300	–	667	553	400	15	15	55
-53E	PC2-4200	–	–	553	400	15	15	55
-40E	PC2-3200	–	–	400	400	15	15	55



Table 2: Addressing

Parameter	1GB	2GB	4GB
Refresh count	8K	8K	8K
Row address	16K A[13:0]	16K A[13:0]	32K A[14:0]
Device bank address	4 BA[1:0]	8 BA[2:0]	8 BA[2:0]
Device configuration	512Mb (128 Meg x 4)	1Gb (256 Meg x 4)	2Gb (512 Meg x 4)
Column address	2K A[11, 9:0]	2K A[11, 9:0]	2K A[11, 9:0]
Module rank address	1 S0#	1 S0#	1 S0#

Table 3: Part Numbers and Timing Parameters – 1GB

Base device: MT47H128M4,¹ 512Mb DDR2 SDRAM

Part Number ²	Module Density	Configuration	Module Bandwidth	Memory Clock/ Data Rate	Clock Cycles (CL- ^t RCD- ^t RP)
MT18HVF12872PZ-80E__	1GB	128 Meg x 72	6.4 GB/s	2.5ns/800 MT/s	5-5-5
MT18HVF12872PZ-800__	1GB	128 Meg x 72	6.4 GB/s	2.5ns/800 MT/s	6-6-6
MT18HVF12872PZ-667__	1GB	128 Meg x 72	5.3 GB/s	3.0ns/667 MT/s	5-5-5

Table 4: Part Numbers and Timing Parameters – 2GB

Base device: MT47H256M4,¹ 1Gb DDR2 SDRAM

Part Number ²	Module Density	Configuration	Module Bandwidth	Memory Clock/ Data Rate	Clock Cycles (CL- ^t RCD- ^t RP)
MT18HVF25672PZ-80E__	2GB	256 Meg x 72	6.4 GB/s	2.5ns/800 MT/s	5-5-5
MT18HVF25672PZ-800__	2GB	256 Meg x 72	6.4 GB/s	2.5ns/800 MT/s	6-6-6
MT18HVF25672PZ-667__	2GB	256 Meg x 72	5.3 GB/s	3.0ns/667 MT/s	5-5-5

Table 5: Part Numbers and Timing Parameters – 4GB

Base device: MT47H512M4,¹ 2Gb DDR2 SDRAM

Part Number ²	Module Density	Configuration	Module Bandwidth	Memory Clock/ Data Rate	Clock Cycles (CL- ^t RCD- ^t RP)
MT18HVF51272PZ-80E__	4GB	512 Meg x 72	6.4 GB/s	2.5ns/800 MT/s	5-5-5
MT18HVF51272PZ-800__	4GB	512 Meg x 72	6.4 GB/s	2.5ns/800 MT/s	6-6-6
MT18HVF51272PZ-667__	4GB	512 Meg x 72	5.3 GB/s	3.0ns/667 MT/s	5-5-5

- Notes:
1. Data sheets for the base device can be found on Micron’s Web site.
 2. All part numbers end with a two-place code (not shown) that designates component and PCB revisions. Consult factory for current revision codes. Example: MT18HVF25672PZ-667H1.



Pin Assignments

Table 6: Pin Assignments

240-Pin VLP RDIMM Front								240-Pin VLP RDIMM Back							
Pin	Symbol	Pin	Symbol	Pin	Symbol	Pin	Symbol	Pin	Symbol	Pin	Symbol	Pin	Symbol	Pin	Symbol
1	V _{REF}	31	DQ19	61	A4	91	V _{SS}	121	V _{SS}	151	V _{SS}	181	V _{DDQ}	211	DQS14
2	V _{SS}	32	V _{SS}	62	V _{DDQ}	92	DQS5#	122	DQ4	152	DQ28	182	A3	212	DQS14#
3	DQ0	33	DQ24	63	A2	93	DQS5	123	DQ5	153	DQ29	183	A1	213	V _{SS}
4	DQ1	34	DQ25	64	V _{DD}	94	V _{SS}	124	V _{SS}	154	V _{SS}	184	V _{DD}	214	DQ46
5	V _{SS}	35	V _{SS}	65	V _{SS}	95	DQ42	125	DQS9	155	DQS12	185	CK0	215	DQ47
6	DQS0#	36	DQS3#	66	V _{SS}	96	DQ43	126	DQS9#	156	DQS12#	186	CK0#	216	V _{SS}
7	DQS0	37	DQS3	67	V _{DD}	97	V _{SS}	127	V _{SS}	157	V _{SS}	187	V _{DD}	217	DQ52
8	V _{SS}	38	V _{SS}	68	Par_In	98	DQ48	128	DQ6	158	DQ30	188	A0	218	DQ53
9	DQ2	39	DQ26	69	V _{DD}	99	DQ49	129	DQ7	159	DQ31	189	V _{DD}	219	V _{SS}
10	DQ3	40	DQ27	70	A10	100	V _{SS}	130	V _{SS}	160	V _{SS}	190	BA1	220	NC
11	V _{SS}	41	V _{SS}	71	BA0	101	SA2	131	DQ12	161	CB4	191	V _{DDQ}	221	NC
12	DQ8	42	CB0	72	V _{DDQ}	102	NC	132	DQ13	162	CB5	192	RAS#	222	V _{SS}
13	DQ9	43	CB1	73	WE#	103	V _{SS}	133	V _{SS}	163	V _{SS}	193	S0#	223	DQS15
14	V _{SS}	44	V _{SS}	74	CAS#	104	DQS6#	134	DQS10	164	DQS17	194	V _{DDQ}	224	DQS15#
15	DQS1#	45	DQS8#	75	V _{DDQ}	105	DQS6	135	DQS10#	165	DQS17#	195	ODT0	225	V _{SS}
16	DQS1	46	DQS8	76	NC	106	V _{SS}	136	V _{SS}	166	V _{SS}	196	A13	226	DQ54
17	V _{SS}	47	V _{SS}	77	NC	107	DQ50	137	NC	167	CB6	197	V _{DD}	227	DQ55
18	RESET#	48	CB2	78	V _{DDQ}	108	DQ51	138	NC	168	CB7	198	V _{SS}	228	V _{SS}
19	NC	49	CB3	79	V _{SS}	109	V _{SS}	139	V _{SS}	169	V _{SS}	199	DQ36	229	DQ60
20	V _{SS}	50	V _{SS}	80	DQ32	110	DQ56	140	DQ14	170	V _{DDQ}	200	DQ37	230	DQ61
21	DQ10	51	V _{DDQ}	81	DQ33	111	DQ57	141	DQ15	171	NC	201	V _{SS}	231	V _{SS}
22	DQ11	52	CKE0	82	V _{SS}	112	V _{SS}	142	V _{SS}	172	V _{DD}	202	DQS13	232	DQS16
23	V _{SS}	53	V _{DD}	83	DQS4#	113	DQS7#	143	DQ20	173	A15	203	DQS13#	233	DQS16#
24	DQ16	54	BA2	84	DQS4	114	DQS7	144	DQ21	174	A14	204	V _{SS}	234	V _{SS}
25	DQ17	55	Err_Out#	85	V _{SS}	115	V _{SS}	145	V _{SS}	175	V _{DDQ}	205	DQ38	235	DQ62
26	V _{SS}	56	V _{DDQ}	86	DQ34	116	DQ58	146	DQS11	176	A12	206	DQ39	236	DQ63
27	DQS2#	57	A11	87	DQ35	117	DQ59	147	DQS11#	177	A9	207	V _{SS}	237	V _{SS}
28	DQS2	58	A7	88	V _{SS}	118	V _{SS}	148	V _{SS}	178	V _{DD}	208	DQ44	238	V _{DDSPD}
29	V _{SS}	59	V _{DD}	89	DQ40	119	SDA	149	DQ22	179	A8	209	DQ45	239	SA0
30	DQ18	60	A5	90	DQ41	120	SCL	150	DQ23	180	A6	210	V _{SS}	240	SA1

Pin Descriptions

The pin description table below is a comprehensive list of all possible pins for all DDR2 modules. All pins listed may not be supported on this module. See Pin Assignments for information specific to this module.

Table 7: Pin Descriptions

Symbol	Type	Description
Ax	Input	Address inputs: Provide the row address for ACTIVE commands, and the column address and auto precharge bit (A10) for READ/WRITE commands, to select one location out of the memory array in the respective bank. A10 sampled during a PRECHARGE command determines whether the PRECHARGE applies to one bank (A10 LOW, bank selected by BAx) or all banks (A10 HIGH). The address inputs also provide the op-code during a LOAD MODE command. See the Pin Assignments Table for density-specific addressing information.
BAx	Input	Bank address inputs: Define the device bank to which an ACTIVE, READ, WRITE, or PRECHARGE command is being applied. BA define which mode register (MR0, MR1, MR2, and MR3) is loaded during the LOAD MODE command.
CKx, CK#x	Input	Clock: Differential clock inputs. All control, command, and address input signals are sampled on the crossing of the positive edge of CK and the negative edge of CK#.
CKEx	Input	Clock enable: Enables (registered HIGH) and disables (registered LOW) internal circuitry and clocks on the DDR2 SDRAM.
DMx	Input	Data mask (x8 devices only): DM is an input mask signal for write data. Input data is masked when DM is sampled HIGH, along with that input data, during a write access. Although DM pins are input-only, DM loading is designed to match that of the DQ and DQS pins.
ODTx	Input	On-die termination: Enables (registered HIGH) and disables (registered LOW) termination resistance internal to the DDR2 SDRAM. When enabled in normal operation, ODT is only applied to the following pins: DQ, DQS, DQS#, DM, and CB. The ODT input will be ignored if disabled via the LOAD MODE command.
Par_In	Input	Parity input: Parity bit for Ax, RAS#, CAS#, and WE#.
RAS#, CAS#, WE#	Input	Command inputs: RAS#, CAS#, and WE# (along with S#) define the command being entered.
RESET#	Input	Reset: Asynchronously forces all registered outputs LOW when RESET# is LOW. This signal can be used during power-up to ensure that CKE is LOW and DQ are High-Z.
S#x	Input	Chip select: Enables (registered LOW) and disables (registered HIGH) the command decoder.
SAx	Input	Serial address inputs: Used to configure the SPD EEPROM address range on the I ² C bus.
SCL	Input	Serial clock for SPD EEPROM: Used to synchronize communication to and from the SPD EEPROM on the I ² C bus.
CBx	I/O	Check bits. Used for system error detection and correction.
DQx	I/O	Data input/output: Bidirectional data bus.
DQSx, DQS#x	I/O	Data strobe: Travels with the DQ and is used to capture DQ at the DRAM or the controller. Output with read data; input with write data for source synchronous operation. DQS# is only used when differential data strobe mode is enabled via the LOAD MODE command.

Table 7: Pin Descriptions (Continued)

Symbol	Type	Description
SDA	I/O	Serial data: Used to transfer addresses and data into and out of the SPD EEPROM on the I ² C bus.
RDQSx, RDQS#x	Output	Redundant data strobe (x8 devices only): RDQS is enabled/disabled via the LOAD MODE command to the extended mode register (EMR). When RDQS is enabled, RDQS is output with read data only and is ignored during write data. When RDQS is disabled, RDQS becomes data mask (see DMx). RDQS# is only used when RDQS is enabled and differential data strobe mode is enabled.
Err_Out#	Output (open drain)	Parity error output: Parity error found on the command and address bus.
V _{DD} /V _{DDQ}	Supply	Power supply: 1.8V ±0.1V. The component V _{DD} and V _{DDQ} are connected to the module V _{DD} .
V _{DDSPD}	Supply	SPD EEPROM power supply: 1.7–3.6V.
V _{REF}	Supply	Reference voltage: V _{DD} /2.
V _{SS}	Supply	Ground.
NC	–	No connect: These pins are not connected on the module.
NF	–	No function: These pins are connected within the module, but provide no functionality.
NU	–	Not used: These pins are not used in specific module configurations/operations.
RFU	–	Reserved for future use.

Functional Block Diagram

Figure 2: Functional Block Diagram

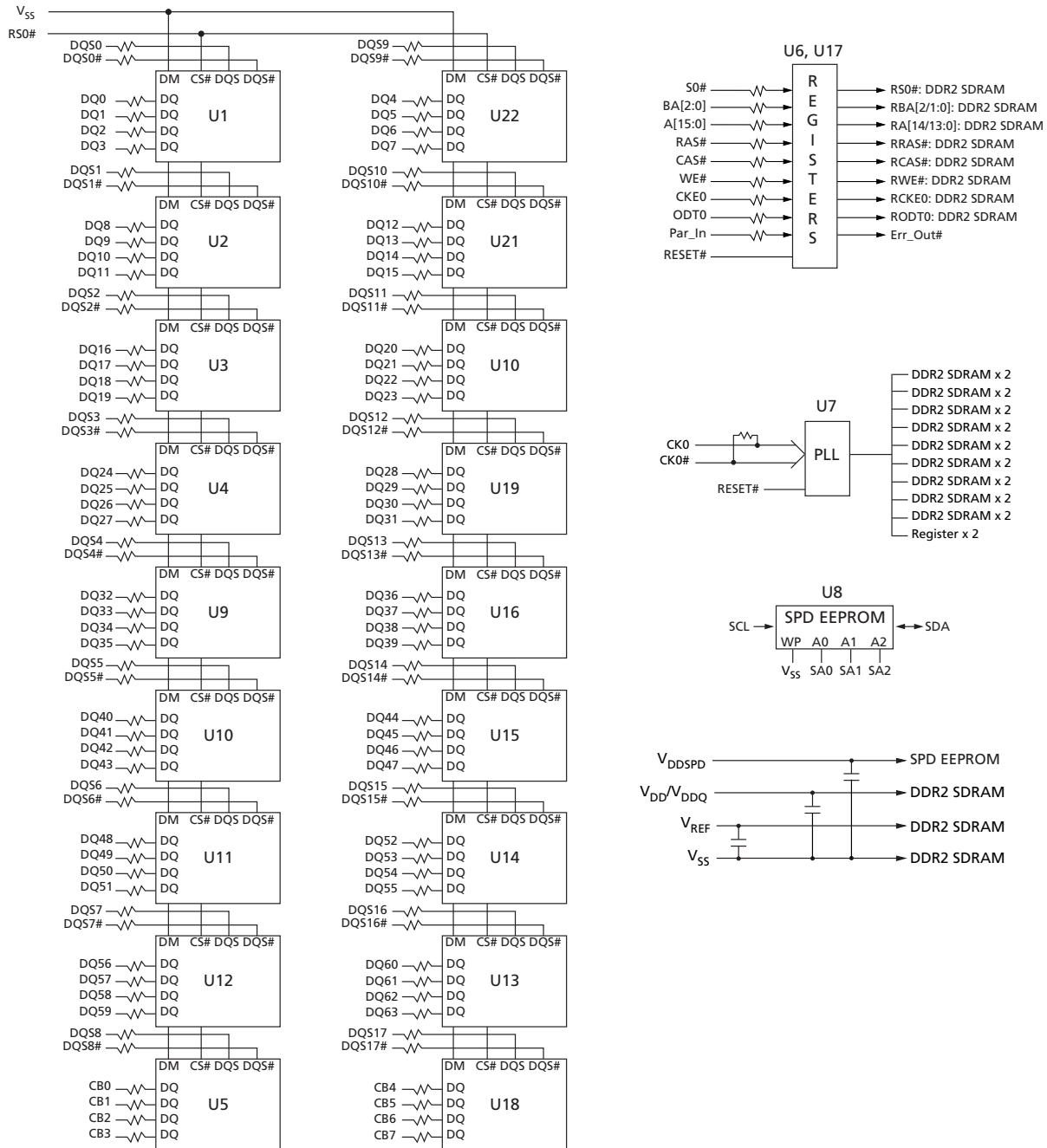

General Description

DDR2 SDRAM modules are high-speed, CMOS dynamic random access memory modules that use internally configured 4 or 8-bank DDR2 SDRAM devices. DDR2 SDRAM modules use DDR architecture to achieve high-speed operation. DDR2 architecture is essentially a $4n$ -prefetch architecture with an interface designed to transfer two data words per clock cycle at the I/O pins. A single read or write access for the DDR2 SDRAM module effectively consists of a single $4n$ -bit-wide, one-clock-cycle data transfer at the internal DRAM core and eight corresponding n -bit-wide, one-half-clock-cycle data transfers at the I/O pins.

DDR2 modules use two sets of differential signals: DQS, DQS# to capture data and CK and CK# to capture commands, addresses, and control signals. Differential clocks and data strobes ensure exceptional noise immunity for these signals and provide precise crossing points to capture input signals. A bidirectional data strobe (DQS, DQS#) is transmitted externally, along with data, for use in data capture at the receiver. DQS is a strobe transmitted by the DDR2 SDRAM device during READs and by the memory controller during WRITEs. DQS is edge-aligned with data for READs and center-aligned with data for WRITEs.

DDR2 SDRAM modules operate from a differential clock (CK and CK#); the crossing of CK going HIGH and CK# going LOW will be referred to as the positive edge of CK. Commands (address and control signals) are registered at every positive edge of CK. Input data is registered on both edges of DQS, and output data is referenced to both edges of DQS, as well as to both edges of CK.

Serial Presence-Detect EEPROM Operation

DDR2 SDRAM modules incorporate serial presence-detect. The SPD data is stored in a 256-byte EEPROM. The first 128 bytes are programmed by Micron to identify the module type and various SDRAM organizations and timing parameters. The remaining 128 bytes of storage are available for use by the customer. System READ/WRITE operations between the master (system logic) and the slave EEPROM device occur via a standard I²C bus using the DIMM's SCL (clock) SDA (data), and SA (address) pins. Write protect (WP) is connected to V_{SS}, permanently disabling hardware write protection.

Register and PLL Operation

DDR2 SDRAM modules operate in registered mode, where the command/address input signals are latched in the registers on the rising clock edge and sent to the DDR2 SDRAM devices on the following rising clock edge (data access is delayed by one clock cycle). A phase-lock loop (PLL) on the module receives and redrives the differential clock signals (CK, CK#) to the DDR2 SDRAM devices. The registers and PLL minimize system and clock loading. PLL clock timing is defined by JEDEC specifications and ensured by use of the JEDEC clock reference board. Registered mode will add one clock cycle to CL.

Parity Operations

The registering clock driver can accept a parity bit from the system's memory controller, providing even parity for the control, command, and address bus. Parity errors are flagged on the Err_Out# pin. Systems not using parity are expected to function without issue if Par_In and Err_Out# are left as no connects (NC) to the system.

Electrical Specifications

Stresses greater than those listed may cause permanent damage to the module. This is a stress rating only, and functional operation of the module at these or any other conditions outside those indicated in each device's data sheet is not implied. Exposure to absolute maximum rating conditions for extended periods may adversely affect reliability.

Table 8: Absolute Maximum Ratings

Symbol	Parameter	Min	Max	Units	
V_{DD}/V_{DDQ}	V_{DD}/V_{DDQ} supply voltage relative to V_{SS}	-0.5	2.3	V	
V_{IN}, V_{OUT}	Voltage on any pin relative to V_{SS}	-0.5	2.3	V	
I_I	Input leakage current; Any input $0V \leq V_{IN} \leq V_{DD}$; V_{REF} input $0V \leq V_{IN} \leq 0.95V$; (All other pins not under test = $0V$)	Command/Address, RAS#, CAS#, WE#, S#, CKE, ODT, BA	-5	5	μA
		CK, CK#	-250	250	
I_{OZ}	Output leakage current; $0V \leq V_{OUT} \leq V_{DDQ}$; DQ and ODT are disabled	DQ, DQS, DQS#	-5	5	μA
I_{VREF}	V_{REF} leakage current; V_{REF} = Valid V_{REF} level		-36	36	μA
T_A	Module ambient operating temperature	Commercial	0	70	$^{\circ}C$
T_C^1	DDR2 SDRAM device operating case temperature ²	Commercial	0	85	$^{\circ}C$

- Notes: 1. The refresh rate is required to double when $85^{\circ}C < T_C \leq 95^{\circ}C$.
2. For further information, refer to technical note TN-00-08: "Thermal Applications," available on Micron's Web site.

DRAM Operating Conditions

Recommended AC operating conditions are given in the DDR2 component data sheets. Component specifications are available on Micron's Web site. Module speed grades correlate with component speed grades.

Table 9: Module and Component Speed Grades

DDR2 components may exceed the listed module speed grades; module may not be available in all listed speed grades

Module Speed Grade	Component Speed Grade
-1GA	-187E
-80E	-25E
-800	-25
-667	-3
-53E	-37E
-40E	-5E

Design Considerations

Simulations

Micron memory modules are designed to optimize signal integrity through carefully designed terminations, controlled board impedances, routing topologies, trace length matching, and decoupling. However, good signal integrity starts at the system level. Micron encourages designers to simulate the signal characteristics of the system's memory bus to ensure adequate signal integrity of the entire memory system.

Power

Operating voltages are specified at the DRAM, not at the edge connector of the module. Designers must account for any system voltage drops at anticipated power levels to ensure the required supply voltage is maintained.

IDD Specifications

Table 10: DDR2 I_{DD} Specifications and Conditions – 1GB (Die Revision G)

Values shown for MT47H128M4 DDR2 SDRAM only and are computed from values specified in the 512Mb (64 Meg x 4) component data sheet

Parameter	Symbol	-80E/ -800	-667	Units	
Operating one bank active-precharge current: $t_{CK} = t_{CK}(I_{DD})$, $t_{RC} = t_{RC}(I_{DD})$, $t_{RAS} = t_{RAS\ MIN}(I_{DD})$; CKE is HIGH, S# is HIGH between valid commands; Address bus inputs are switching; Data bus inputs are switching	I _{DD0}	1170	1080	mA	
Operating one bank active-read-precharge current: I _{OUT} = 0mA; BL = 4, CL = CL(I _{DD}), AL = 0; $t_{CK} = t_{CK}(I_{DD})$, $t_{RC} = t_{RC}(I_{DD})$, $t_{RAS} = t_{RAS\ MIN}(I_{DD})$, $t_{RCD} = t_{RCD}(I_{DD})$; CKE is HIGH, S# is HIGH between valid commands; Address bus inputs are switching; Data pattern is same as I _{DD4W}	I _{DD1}	1350	1260	mA	
Precharge power-down current: All device banks idle; $t_{CK} = t_{CK}(I_{DD})$; CKE is LOW; Other control and address bus inputs are stable; Data bus inputs are floating	I _{DD2P}	126	126	mA	
Precharge quiet standby current: All device banks idle; $t_{CK} = t_{CK}(I_{DD})$; CKE is HIGH, S# is HIGH; Other control and address bus inputs are stable; Data bus inputs are floating	I _{DD2Q}	432	396	mA	
Precharge standby current: All device banks idle; $t_{CK} = t_{CK}(I_{DD})$; CKE is HIGH, S# is HIGH; Other control and address bus inputs are switching; Data bus inputs are switching	I _{DD2N}	504	450	mA	
Active power-down current: All device banks open; $t_{CK} = t_{CK}(I_{DD})$; CKE is LOW; Other control and address bus inputs are stable; Data bus inputs are floating	I _{DD3P}	Fast PDN exit MR[12] = 0	324	270	mA
		Slow PDN exit MR[12] = 1	162	162	
Active standby current: All device banks open; $t_{CK} = t_{CK}(I_{DD})$, $t_{RAS} = t_{RAS\ MAX}(I_{DD})$, $t_{RP} = t_{RP}(I_{DD})$; CKE is HIGH, S# is HIGH between valid commands; Other control and address bus inputs are switching; Data bus inputs are switching	I _{DD3N}	594	540	mA	
Operating burst write current: All device banks open; Continuous burst writes; BL = 4, CL = CL(I _{DD}), AL = 0; $t_{CK} = t_{CK}(I_{DD})$, $t_{RAS} = t_{RAS\ MAX}(I_{DD})$, $t_{RP} = t_{RP}(I_{DD})$; CKE is HIGH, S# is HIGH between valid commands; Address bus inputs are switching; Data bus inputs are switching	I _{DD4W}	2250	2070	mA	
Operating burst read current: All device banks open; Continuous burst read, I _{OUT} = 0mA; BL = 4, CL = CL(I _{DD}), AL = 0; $t_{CK} = t_{CK}(I_{DD})$, $t_{RAS} = t_{RAS\ MAX}(I_{DD})$, $t_{RP} = t_{RP}(I_{DD})$; CKE is HIGH, S# is HIGH between valid commands; Address bus inputs are switching; Data bus inputs are switching	I _{DD4R}	2160	1980	mA	
Burst refresh current: $t_{CK} = t_{CK}(I_{DD})$; REFRESH command at every $t_{RFC}(I_{DD})$ interval; CKE is HIGH, S# is HIGH between valid commands; Other control and address bus inputs are switching; Data bus inputs are switching	I _{DD5}	1710	1620	mA	
Self refresh current: CK and CK# at 0V; CKE ≤ 0.2V; Other control and address bus inputs are floating; Data bus inputs are floating	I _{DD6}	126	126	mA	
Operating bank interleave read current: All device banks interleaving reads, I _{OUT} = 0mA; BL = 4, CL = CL(I _{DD}), AL = $t_{RCD}(I_{DD}) - 1 \times t_{CK}(I_{DD})$; $t_{CK} = t_{CK}(I_{DD})$, $t_{RC} = t_{RC}(I_{DD})$, $t_{RRD} = t_{RRD}(I_{DD})$, $t_{RCD} = t_{RCD}(I_{DD})$; CKE is HIGH, S# is HIGH between valid commands; Address bus inputs are stable during deselects; Data bus inputs are switching	I _{DD7}	54	54	mA	

Table 11: DDR2 I_{DD} Specifications and Conditions – 2GB (Die Revision H)

Values shown for MT47H256M4 DDR2 SDRAM only and are computed from values specified in the 1Gb (128 Meg x 4) component data sheet

Parameter	Symbol	-80E/ -800	-667	Units	
Operating one bank active-precharge current: $t_{CK} = t_{CK}(I_{DD})$, $t_{RC} = t_{RC}(I_{DD})$, $t_{RAS} = t_{RAS\ MIN}(I_{DD})$; CKE is HIGH, S# is HIGH between valid commands; Address bus inputs are switching; Data bus inputs are switching	I _{DD0}	1170	1080	mA	
Operating one bank active-read-precharge current: I _{OUT} = 0mA; BL = 4, CL = CL(I _{DD}), AL = 0; $t_{CK} = t_{CK}(I_{DD})$, $t_{RC} = t_{RC}(I_{DD})$, $t_{RAS} = t_{RAS\ MIN}(I_{DD})$, $t_{RCD} = t_{RCD}(I_{DD})$; CKE is HIGH, S# is HIGH between valid commands; Address bus inputs are switching; Data pattern is same as I _{DD4W}	I _{DD1}	1350	1260	mA	
Precharge power-down current: All device banks idle; $t_{CK} = t_{CK}(I_{DD})$; CKE is LOW; Other control and address bus inputs are stable; Data bus inputs are floating	I _{DD2P}	126	126	mA	
Precharge quiet standby current: All device banks idle; $t_{CK} = t_{CK}(I_{DD})$; CKE is HIGH, S# is HIGH; Other control and address bus inputs are stable; Data bus inputs are floating	I _{DD2Q}	432	432	mA	
Precharge standby current: All device banks idle; $t_{CK} = t_{CK}(I_{DD})$; CKE is HIGH, S# is HIGH; Other control and address bus inputs are switching; Data bus inputs are switching	I _{DD2N}	504	432	mA	
Active power-down current: All device banks open; $t_{CK} = t_{CK}(I_{DD})$; CKE is LOW; Other control and address bus inputs are stable; Data bus inputs are floating	I _{DD3P}	Fast PDN exit MR[12] = 0	360	270	mA
		Slow PDN exit MR[12] = 1	180	180	
Active standby current: All device banks open; $t_{CK} = t_{CK}(I_{DD})$, $t_{RAS} = t_{RAS\ MAX}(I_{DD})$, $t_{RP} = t_{RP}(I_{DD})$; CKE is HIGH, S# is HIGH between valid commands; Other control and address bus inputs are switching; Data bus inputs are switching	I _{DD3N}	594	540	mA	
Operating burst write current: All device banks open; Continuous burst writes; BL = 4, CL = CL(I _{DD}), AL = 0; $t_{CK} = t_{CK}(I_{DD})$, $t_{RAS} = t_{RAS\ MAX}(I_{DD})$, $t_{RP} = t_{RP}(I_{DD})$; CKE is HIGH, S# is HIGH between valid commands; Address bus inputs are switching; Data bus inputs are switching	I _{DD4W}	2250	2070	mA	
Operating burst read current: All device banks open; Continuous burst read, I _{OUT} = 0mA; BL = 4, CL = CL(I _{DD}), AL = 0; $t_{CK} = t_{CK}(I_{DD})$, $t_{RAS} = t_{RAS\ MAX}(I_{DD})$, $t_{RP} = t_{RP}(I_{DD})$; CKE is HIGH, S# is HIGH between valid commands; Address bus inputs are switching; Data bus inputs are switching	I _{DD4R}	2160	1980	mA	
Burst refresh current: $t_{CK} = t_{CK}(I_{DD})$; REFRESH command at every $t_{RFC}(I_{DD})$ interval; CKE is HIGH, S# is HIGH between valid commands; Other control and address bus inputs are switching; Data bus inputs are switching	I _{DD5}	2610	2520	mA	
Self refresh current: CK and CK# at 0V; CKE ≤ 0.2V; Other control and address bus inputs are floating; Data bus inputs are floating	I _{DD6}	126	126	mA	
Operating bank interleave read current: All device banks interleaving reads, I _{OUT} = 0mA; BL = 4, CL = CL(I _{DD}), AL = $t_{RCD}(I_{DD}) - 1 \times t_{CK}(I_{DD})$; $t_{CK} = t_{CK}(I_{DD})$, $t_{RC} = t_{RC}(I_{DD})$, $t_{RRD} = t_{RRD}(I_{DD})$, $t_{RCD} = t_{RCD}(I_{DD})$; CKE is HIGH, S# is HIGH between valid commands; Address bus inputs are stable during deselects; Data bus inputs are switching	I _{DD7}	3780	3330	mA	

Table 12: DDR2 I_{DD} Specifications and Conditions – 4GB (Die Revision C)

Values shown for MT47H512M4 DDR2 SDRAM only and are computed from values specified in the 2Gb (256 Meg x 4) component data sheet

Parameter	Symbol	-80E/ -800	-667	Units	
Operating one bank active-precharge current: $t_{CK} = t_{CK}(I_{DD})$, $t_{RC} = t_{RC}(I_{DD})$, $t_{RAS} = t_{RAS\ MIN}(I_{DD})$; CKE is HIGH, S# is HIGH between valid commands; Address bus inputs are switching; Data bus inputs are switching	I _{DD0}	TBD	TBD	mA	
Operating one bank active-read-precharge current: I _{OUT} = 0mA; BL = 4, CL = CL(I _{DD}), AL = 0; $t_{CK} = t_{CK}(I_{DD})$, $t_{RC} = t_{RC}(I_{DD})$, $t_{RAS} = t_{RAS\ MIN}(I_{DD})$, $t_{RCD} = t_{RCD}(I_{DD})$; CKE is HIGH, S# is HIGH between valid commands; Address bus inputs are switching; Data pattern is same as I _{DD4W}	I _{DD1}	TBD	TBD	mA	
Precharge power-down current: All device banks idle; $t_{CK} = t_{CK}(I_{DD})$; CKE is LOW; Other control and address bus inputs are stable; Data bus inputs are floating	I _{DD2P}	TBD	TBD	mA	
Precharge quiet standby current: All device banks idle; $t_{CK} = t_{CK}(I_{DD})$; CKE is HIGH, S# is HIGH; Other control and address bus inputs are stable; Data bus inputs are floating	I _{DD2Q}	TBD	TBD	mA	
Precharge standby current: All device banks idle; $t_{CK} = t_{CK}(I_{DD})$; CKE is HIGH, S# is HIGH; Other control and address bus inputs are switching; Data bus inputs are switching	I _{DD2N}	TBD	TBD	mA	
Active power-down current: All device banks open; $t_{CK} = t_{CK}(I_{DD})$; CKE is LOW; Other control and address bus inputs are stable; Data bus inputs are floating	I _{DD3P}	Fast PDN exit MR[12] = 0	TBD	TBD	mA
		Slow PDN exit MR[12] = 1	TBD	TBD	mA
Active standby current: All device banks open; $t_{CK} = t_{CK}(I_{DD})$, $t_{RAS} = t_{RAS\ MAX}(I_{DD})$, $t_{RP} = t_{RP}(I_{DD})$; CKE is HIGH, S# is HIGH between valid commands; Other control and address bus inputs are switching; Data bus inputs are switching	I _{DD3N}	TBD	TBD	mA	
Operating burst write current: All device banks open; Continuous burst writes; BL = 4, CL = CL(I _{DD}), AL = 0; $t_{CK} = t_{CK}(I_{DD})$, $t_{RAS} = t_{RAS\ MAX}(I_{DD})$, $t_{RP} = t_{RP}(I_{DD})$; CKE is HIGH, S# is HIGH between valid commands; Address bus inputs are switching; Data bus inputs are switching	I _{DD4W}	TBD	TBD	mA	
Operating burst read current: All device banks open; Continuous burst read, I _{OUT} = 0mA; BL = 4, CL = CL(I _{DD}), AL = 0; $t_{CK} = t_{CK}(I_{DD})$, $t_{RAS} = t_{RAS\ MAX}(I_{DD})$, $t_{RP} = t_{RP}(I_{DD})$; CKE is HIGH, S# is HIGH between valid commands; Address bus inputs are switching; Data bus inputs are switching	I _{DD4R}	TBD	TBD	mA	
Burst refresh current: $t_{CK} = t_{CK}(I_{DD})$; REFRESH command at every $t_{RFC}(I_{DD})$ interval; CKE is HIGH, S# is HIGH between valid commands; Other control and address bus inputs are switching; Data bus inputs are switching	I _{DD5}	TBD	TBD	mA	
Self refresh current: CK and CK# at 0V; CKE ≤ 0.2V; Other control and address bus inputs are floating; Data bus inputs are floating	I _{DD6}	TBD	TBD	mA	
Operating bank interleave read current: All device banks interleaving reads, I _{OUT} = 0mA; BL = 4, CL = CL(I _{DD}), AL = $t_{RCD}(I_{DD}) - 1 \times t_{CK}(I_{DD})$; $t_{CK} = t_{CK}(I_{DD})$, $t_{RC} = t_{RC}(I_{DD})$, $t_{RRD} = t_{RRD}(I_{DD})$, $t_{RCD} = t_{RCD}(I_{DD})$; CKE is HIGH, S# is HIGH between valid commands; Address bus inputs are stable during deselects; Data bus inputs are switching	I _{DD7}	TBD	TBD	mA	

Register and PLL Specifications

Table 13: Register Specifications

SSTU32866 devices or equivalent

Parameter	Symbol	Pins	Condition	Min	Max	Units
DC high-level input voltage	$V_{IH(DC)}$	Control, command, address	SSTL_18	$V_{REF(DC)} + 125$	$V_{DDQ} + 250$	mV
DC low-level input voltage	$V_{IL(DC)}$	Control, command, address	SSTL_18	0	$V_{REF(DC)} - 125$	mV
AC high-level input voltage	$V_{IH(AC)}$	Control, command, address	SSTL_18	$V_{REF(DC)} + 250$	–	mV
AC low-level input voltage	$V_{IL(AC)}$	Control, command, address	SSTL_18	–	$V_{REF(DC)} - 250$	mV
Output high voltage	V_{OH}	Parity output	LVC MOS	1.2	–	V
Output low voltage	V_{OL}	Parity output	LVC MOS	–	0.5	V
Input current	I_I	All pins	$V_I = V_{DD}$ or V_{SS}	–	± 0.5	μA
Static standby	I_{DD}	All pins	RESET# = V_{SSQ} ($I_O = 0$)	–	100	μA
Static operating	I_{DD}	All pins	RESET# = V_{SS} ; $V_I = V_{IH(AC)}$ or $V_{IL(DC)}$ $I_O = 0$	–	40	mA
Dynamic operating (clock tree)	I_{DDD}	N/A	RESET# = V_{DD} ; $V_I = V_{IH(DC)}$ or $V_{IL(AC)}$, $I_O = 0$; CK and CK# switching 50% duty cycle	–	Varies by manufacturer	μA
Dynamic operating (per each input)	I_{DDD}	N/A	RESET# = V_{DD} ; $V_I = V_{IH(AC)}$ or $V_{IL(DC)}$, $I_O = 0$; CK and CK# switching 50% duty cycle; One data in/out switching at $t_{CK}/2$, 50% duty cycle	–	Varies by manufacturer	μA
Input capacitance (per device, per pin)	C_{IN}	All inputs except RESET#	$V_I = V_{REF} \pm 250mV$; $V_{DD} = 1.8V$	2.5	3.5	pF
Input capacitance (per device, per pin)	C_{IN}	RESET#	$V_I = V_{DD}$ or V_{SS}	Varies by manufacturer	Varies by manufacturer	pF

Note: 1. Timing and switching specifications for the register listed are critical for proper operation of the DDR2 SDRAM RDIMMs. These are meant to be a subset of the parameters for the specific device used on the module. Detailed information for this register is available in JEDEC standard JESD82.

Table 14: PLL Specifications

CU877 device or equivalent

Parameter	Symbol	Pins	Condition	Min	Max	Units
DC high-level input voltage	V_{IH}	RESET#	LVC MOS	$0.65 \times V_{DD}$	–	V
DC low-level input voltage	V_{IL}	RESET#	LVC MOS	–	$0.35 \times V_{DD}$	V
Input voltage (limits)	V_{IN}	RESET#, CK, CK#	–	0.3	$V_{DD} + 0.3$	V
DC high-level input voltage	V_{IH}	CK, CK#	Differential input	$0.65 \times V_{DD}$	–	V
DC low-level input voltage	V_{IL}	CK, CK#	Differential input	–	$0.35 \times V_{DD}$	V
Input differential-pair cross voltage	V_{IX}	CK, CK#	Differential input	$(V_{DDQ}/2) - 0.15$	$(V_{DD}/2) + 0.15$	V
Input differential voltage	$V_{ID(DC)}$	CK, CK#	Differential input	0.3	$V_{DD} + 0.4$	V
Input differential voltage	$V_{ID(AC)}$	CK, CK#	Differential input	0.6	$V_{DD} + 0.4$	V
Input current	I_I	RESET#	$V_I = V_{DD}$ or V_{SS}	–10	10	μA
		CK, CK#	$V_I = V_{DD}$ or V_{SS}	–250	250	μA
Output disabled current	I_{ODL}		RESET# = V_{SS} ; $V_I = V_{IH(AC)}$ or $V_{IL(DC)}$	100	–	μA
Static supply current	$I_{DDL D}$		CK = CK# = LOW	–	500	μA
Dynamic supply	I_{DD}	N/A	CK, CK# = 270 MHz, all outputs open (not connected to PCB)	–	300	mA
Input capacitance	C_{IN}	Each input	$V_I = V_{DD}$ or V_{SS}	2	3	pF

Table 15: PLL Clock Driver Timing Requirements and Switching Characteristics

Parameter	Symbol	Min	Max	Units
Stabilization time	t_L	–	15	μs
Input clock slew rate	slr(i)	1.0	4.0	V/ns
SSC modulation frequency	–	30	33	kHz
SSC clock input frequency deviation	–	0.0	–0.5	%
PLL loop bandwidth (–3dB from unity gain)	–	2.0	–	MHz

Note: 1. PLL timing and switching specifications are critical for proper operation of the DDR2 DIMM. This is a subset of parameters for the specific PLL used. Detailed PLL information is available in JEDEC standard JESD82.

Serial Presence-Detect

For the latest SPD data, refer to Micron's SPD page: www.micron.com/SPD.

Table 16: SPD EEPROM Operating Conditions

Parameter/Condition	Symbol	Min	Max	Units
Supply voltage	V_{DDSPD}	1.7	3.6	V
Input high voltage: logic 1; All inputs	V_{IH}	$V_{DDSPD} \times 0.7$	$V_{DDSPD} + 0.5$	V
Input low voltage: logic 0; All inputs	V_{IL}	-0.6	$V_{DDSPD} \times 0.3$	V
Output low voltage: $I_{OUT} = 3mA$	V_{OL}	-	0.4	V
Input leakage current: $V_{IN} = GND$ to V_{DD}	I_{LI}	0.1	3	μA
Output leakage current: $V_{OUT} = GND$ to V_{DD}	I_{LO}	0.05	3	μA
Standby current	I_{SB}	1.6	4	μA
Power supply current, READ: SCL clock frequency = 100 kHz	I_{CCR}	0.4	1	mA
Power supply current, WRITE: SCL clock frequency = 100 kHz	I_{CCW}	2	3	mA

Table 17: SPD EEPROM AC Operating Conditions

Parameter/Condition	Symbol	Min	Max	Units	Notes
SCL LOW to SDA data-out valid	t_{AA}	0.2	0.9	μs	1
Time bus must be free before a new transition can start	t_{BUF}	1.3	-	μs	
Data-out hold time	t_{DH}	200	-	ns	
SDA and SCL fall time	t_F	-	300	ns	2
SDA and SCL rise time	t_R	-	300	ns	2
Data-in hold time	$t_{HD:DAT}$	0	-	μs	
Start condition hold time	$t_{HD:STA}$	0.6	-	μs	
Clock HIGH period	t_{HIGH}	0.6	-	μs	
Noise suppression time constant at SCL, SDA inputs	t_{η}	-	50	ns	
Clock LOW period	t_{LOW}	1.3	-	μs	
SCL clock frequency	t_{SCL}	-	400	kHz	
Data-in setup time	$t_{SU:DAT}$	100	-	ns	
Start condition setup time	$t_{SU:STA}$	0.6	-	μs	3
Stop condition setup time	$t_{SU:STO}$	0.6	-	μs	
WRITE cycle time	t_{WRC}	-	10	ms	4

- Notes:
1. To avoid spurious start and stop conditions, a minimum delay is placed between SCL = 1 and the falling or rising edge of SDA.
 2. This parameter is sampled.
 3. For a restart condition or following a WRITE cycle.
 4. The SPD EEPROM WRITE cycle time (t_{WRC}) is the time from a valid stop condition of a write sequence to the end of the EEPROM internal ERASE/PROGRAM cycle. During the WRITE cycle, the EEPROM bus interface circuit is disabled, SDA remains HIGH due to pull-up resistance, and the EEPROM does not respond to its slave address.

