

LM5117

Wide Input Range Synchronous Buck Controller with Analog Current Monitor

General Description

The LM5117 is a synchronous buck controller intended for step-down regulator applications from a high voltage or widely varying input supply. The control method is based upon current mode control utilizing an emulated current ramp. Current mode control provides inherent line feed-forward, cycle-by-cycle current limiting and ease of loop compensation. The use of an emulated control ramp reduces noise sensitivity of the pulse-width modulation circuit, allowing reliable control of very small duty cycles necessary in high input voltage applications.

The operating frequency is programmable from 50 kHz to 750 kHz. The LM5117 drives external high-side and low-side NMOS power switches with adaptive dead-time control. A user-selectable diode emulation mode enables discontinuous mode operation for improved efficiency at light load conditions. A high voltage bias regulator that allows external bias supply further improves efficiency. The LM5117's unique analog telemetry feature provides average output current information. Additional features include thermal shutdown, frequency synchronization, hiccup mode current limit and adjustable line under-voltage lockout.

Features

- Emulated peak current mode control
- Wide operating range from 5.5V to 65V
- Robust 3.3A peak gate drives
- Adaptive dead-time output driver control
- Free-run or synchronizable clock up to 750kHz
- Optional diode emulation mode
- Programmable output from 0.8V
- Precision 1.5% voltage reference
- Analog current monitor
- Programmable current limit
- Hiccup mode over current protection
- Programmable soft-start and tracking
- Programmable line under-voltage lockout
- Programmable switch-over to external bias supply
- Thermal shutdown

Packages

- TSSOP-20EP (Thermally enhanced)
- LLP-24 (4mmx4mm)

Typical Application

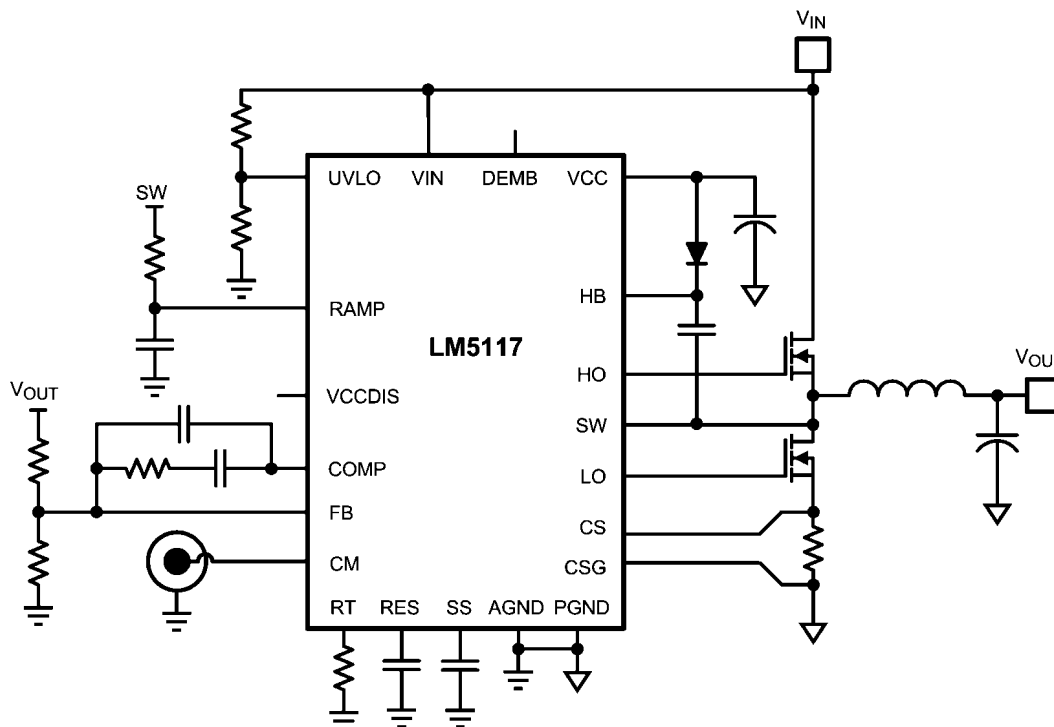

30143201

Connection Diagrams

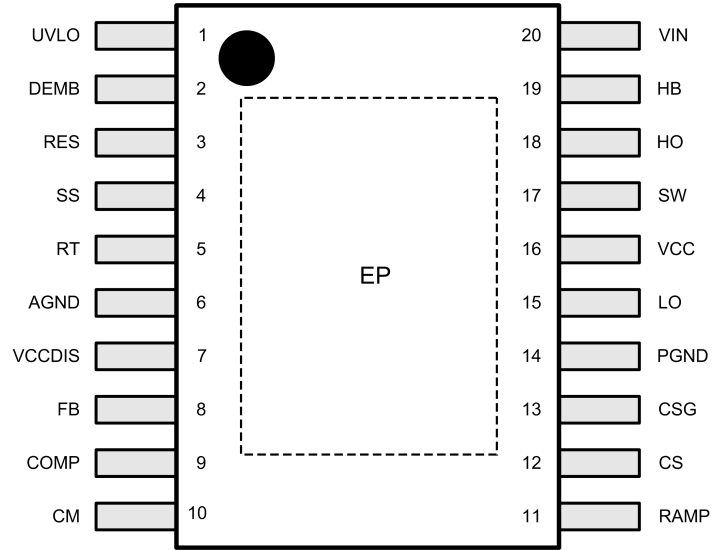

30143279

**Top View
20-Lead TSSOP EP**

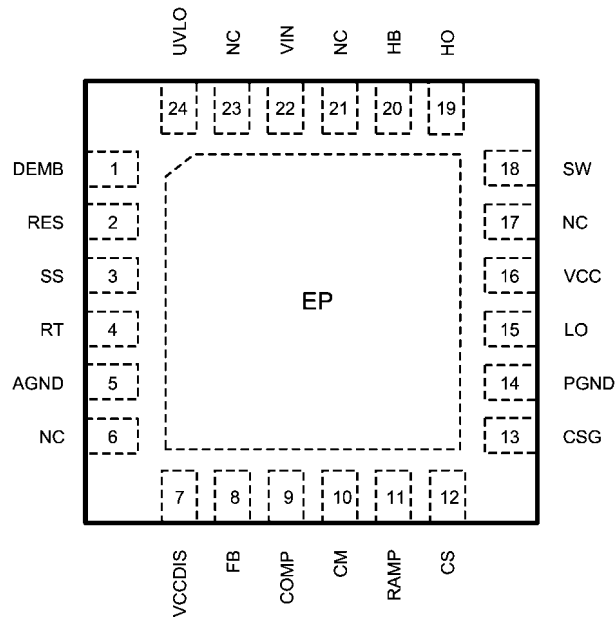

30143202

**Top View
LLP-24 (4mmx4mm)**

Ordering Information

Order Number	Package Type	NSC Package Drawing	Supplied As	Feature
LM5117PMH	TSSOP-20EP	MXA20A	73 Units Per Rail	
LM5117PMHE	TSSOP-20EP	MXA20A	250 Units on Tape and Reel	
LM5117PMHX	TSSOP-20EP	MXA20A	2500 Units on Tape and Reel	
LM5117PSQ	LLP-24	SQA24A	1000 Units on Tape and Reel	
LM5117PSQE	LLP-24	SQA24A	250 Units on Tape and Reel	
LM5117PSQX	LLP-24	SQA24A	4500 Units on Tape and Reel	

Pin Descriptions

TSSOP Pin	LLP Pin	Name	Description
1	24	UVLO	Under-voltage lockout programming pin. If the UVLO pin voltage is below 0.4V, the regulator is in the shutdown mode with all functions disabled. If the UVLO pin voltage is greater than 0.4V and less than 1.25V, the regulator is in standby mode with the VCC regulator operational, the SS pin grounded, and no switching at the HO and LO outputs. If the UVLO pin voltage is above 1.25V, the SS pin is allowed to ramp and pulse width modulated gate drive signals are delivered to the HO and LO pins. A 20 μ A current source is enabled when UVLO exceeds 1.25V and flows through the external UVLO resistors to provide hysteresis.
2	1	DEMB	Optional logic input that enables diode emulation when in the low state. In diode emulation mode, the low-side NMOS is latched off for the remainder of the PWM cycle after detecting reverse current flow (current flow from output to ground through the low-side NMOS). When DEMB is high, diode emulation is disabled allowing current to flow in either direction through the low-side NMOS. A 50k Ω pull-down resistor internal to the LM5117 holds DEMB pin low and enables diode emulation if the pin is left floating.
3	2	RES	The restart timer pin that configures the hiccup mode current limiting. A capacitor on the RES pin determines the time the controller remains off before automatically restarting. The hiccup mode commences when the controller experiences 256 consecutive PWM cycles of cycle-by-cycle current limiting. After this occurs, an 10 μ A current source charges the RES pin capacitor to the 1.25V threshold and restarts LM5117.
4	3	SS	An external capacitor and an internal 10 μ A current source set the ramp rate of the error amplifier reference during soft-start. The SS pin is held low when VCC < 5V, UVLO < 1.25V or during thermal shutdown.
5	4	RT	The internal oscillator is programmed with a single resistor between RT and the AGND. The recommended maximum oscillator frequency is 750kHz. The internal oscillator can be synchronized to an external clock by coupling a positive pulse into the RT pin through a small coupling capacitor.
6	5	AGND	Analog ground. Return for the internal 0.8V voltage reference and analog circuits.
7	7	VCCDIS	Optional input that disables the internal VCC regulator. If VCCDIS > 1.25V, the internal VCC regulator is disabled. VCCDIS has an internal 500k Ω pull-down resistor to enable the VCC regulator when the pin is left floating. The internal 500k Ω pull-down resistor can be overridden by pulling VCCDIS above 1.25V with a resistor divider connected to an external bias supply.
8	8	FB	Feedback. Inverting input of the internal error amplifier. A resistor divider from the output to this pin sets the output voltage level. The regulation threshold at the FB pin is 0.8V.
9	9	COMP	Output of the internal error amplifier. The loop compensation network should be connected between this pin and the FB pin.
10	10	CM	Current monitor output. Average of the sensed inductor current is provided. Monitor directly between CM and AGND. CM should be left floating when the pin is not used.
11	11	RAMP	PWM ramp signal. An external resistor and capacitor connected between the SW pin, the RAMP pin and the AGND pin sets the PWM ramp slope. Proper selection of component values produces a RAMP signal that emulates the AC component of the inductor with a slope proportional to input supply voltage.
12	12	CS	Current sense amplifier input. Connect to the high-side of the current sense resistor.
13	13	CSG	Kelvin ground connection to the current sense resistor. Connect directly to the low-side of the current sense resistor.
14	14	PGND	Power ground return pin for low-side NMOS gate driver. Connect directly to the low-side of the current sense resistor.
15	15	LO	Low-side NMOS gate drive output. Connect to the gate of the low-side synchronous NMOS transistor through a short, low inductance path.
16	16	VCC	Bias supply pin. Locally decouple to PGND using a low ESR/ESL capacitor located as close to controller as possible.
17	18	SW	Switching node of the buck regulator. Connect to the bootstrap capacitor, the source terminal of the high-side NMOS transistor and the drain terminal of the low-side NMOS through a short, low inductance path.

TSSOP Pin	LLP Pin	Name	Description
18	19	HO	High-side NMOS gate drive output. Connect to the gate of the high-side NMOS transistor through a short, low inductance path.
19	20	HB	High-side driver supply for the bootstrap gate drive. Connect to the cathode of the external bootstrap diode and to the bootstrap capacitor. The bootstrap capacitor supplies current to charge the high-side NMOS gate and should be placed as close to controller as possible.
20	22	VIN	Supply voltage input source for the VCC regulator.
EP	EP	EP	Exposed pad of the package. Electrically isolated. Should be soldered to the ground plane to reduce thermal resistance.
	6	NC	No electrical contact.
	17	NC	No electrical contact.
	21	NC	No electrical contact.
	23	NC	No electrical contact.

Absolute Maximum Ratings (Note 1)

VIN to AGND	-0.3 to 75V
SW to AGND	-3.0 to 75V
HB to SW	-0.3 to 15V
VCC to AGND <small>(Note 2)</small>	-0.3 to 15V
HO to SW	-0.3 to HB+0.3V
LO to AGND	-0.3 to VCC+0.3V
FB, DEMB, RES, VCCDIS, UVLO to AGND	-0.3 to 15V
CM, COMP to AGND <small>(Note 3)</small>	-0.3 to 7V

SS, RAMP, RT to AGND	-0.3 to 7V
CS, CSG, PGND, to AGND	-0.3 to 0.3V
ESD Rating HBM <small>(Note 4)</small>	2kV
Storage Temperature	-55°C to +150°C
Junction Temperature	+150°C

Operating Ratings (Note 1)

VIN <small>(Note 5)</small>	5.5V to 65V
VCC	5.5V to 14V
HB to SW	5.5V to 14V
Junction Temperature	-40°C to +125°C

Electrical Characteristics Limits in standard type are for $T_J = 25^\circ\text{C}$ only; limits in **boldface type** apply over the junction temperature range of -40°C to $+125^\circ\text{C}$. Minimum and Maximum limits are guaranteed through test, design, or statistical correlation. Typical values represent the most likely parametric norm at $T_J = 25^\circ\text{C}$, and are provided for reference purposes only. Unless otherwise specified, the following conditions apply: $V_{\text{VIN}} = 48\text{V}$, $V_{\text{VCCDIS}} = 0\text{V}$, $R_T = 25\text{k}\Omega$, no load on LO & HO.

Symbol	Parameter	Conditions	Min	Typ	Max	Units
VIN Supply						
I_{BIAS}	VIN Operating Current <small>(Note 6)</small>	$V_{\text{SS}} = 0\text{V}$		4.8	6.2	mA
		$V_{\text{SS}} = 0\text{V}$, $V_{\text{VCCDIS}} = 2\text{V}$		0.4	0.55	mA
I_{SHUTDOWN}	VIN Shutdown Current	$V_{\text{SS}} = 0\text{V}$, $V_{\text{UVLO}} = 0\text{V}$		16	40	μA
VCC Regulator						
$V_{\text{CC(REG)}}$	VCC Regulation	No Load	6.85	7.6	8.2	V
	VCC Dropout (VIN to VCC)	$V_{\text{VIN}} = 5.5\text{V}$, No external load		0.05	0.14	V
		$V_{\text{VIN}} = 6.0\text{V}$, $I_{\text{CC}} = 20\text{mA}$		0.4	0.5	V
	VCC Sourcing Current Limit	$V_{\text{VCC}} = 0\text{V}$	30	42		mA
I_{VCC}	VCC Operating Current <small>(Note 6)</small>	$V_{\text{SS}} = 0\text{V}$, $V_{\text{VCCDIS}} = 2\text{V}$		4.0	5.0	mA
		$V_{\text{SS}} = 0\text{V}$, $V_{\text{VCCDIS}} = 2\text{V}$, $V_{\text{VCC}} = 14\text{V}$		5.8	7.3	mA
	VCC Under-voltage Threshold	VCC Rising	4.7	4.9	5.15	V
	VCC Under-voltage Hysteresis			0.2		V
VCC Disable						
	VCCDIS Threshold	VCCDIS Rising	1.22	1.25	1.29	V
	VCCDIS Hysteresis			0.06		V
	VCCDIS Input Current	$V_{\text{VCCDIS}} = 0\text{V}$		-20		nA
	VCCDIS Pull-down Resistance			500		$\text{k}\Omega$
UVLO						
	UVLO Threshold	UVLO Rising	1.22	1.25	1.29	V
	UVLO Hysteresis Current	$V_{\text{UVLO}} = 1.4\text{V}$	15	20	25	μA
	UVLO Shutdown Threshold	UVLO Falling	0.3	0.4		V
	UVLO Shutdown Hysteresis			0.1		V
Soft Start						
I_{SS}	SS Current Source	$V_{\text{SS}} = 0\text{V}$	7	10	12	μA
	SS Pull-down Resistance			13	24	Ω
Error Amplifier						
V_{REF}	FB Reference Voltage	Measured at FB, FB = COMP	788	800	812	mV
	FB Input Bias Current	$V_{\text{FB}} = 0.8\text{V}$		1		nA
V_{OH}	COMP Output High Voltage	$I_{\text{SOURCE}} = 3\text{mA}$	2.8			V
V_{OL}	COMP Output Low Voltage	$I_{\text{SINK}} = 3\text{mA}$			0.26	V
A_{OL}	DC Gain			80		dB
f_{BW}	Unity Gain Bandwidth			3		MHz
PWM Comparator						
$t_{\text{HO(OFF)}}$	Forced HO Off-time		260	320	440	ns

Symbol	Parameter	Conditions	Min	Typ	Max	Units
$t_{ON(MIN)}$	Minimum HO On-time	$V_{VIN} = 65V$		100		ns
	COMP to PWM comparator offset			1.2		V
Oscillator						
f_{SW1}	Frequency 1	$R_T = 25k\Omega$	180	200	220	kHz
f_{SW2}	Frequency 2	$R_T = 10k\Omega$	430	480	530	kHz
	RT Output Voltage			1.25		V
	RT Sync Positive Threshold		2.6	3.2	3.95	V
	Sync Pulse Width		100			ns
Current Limit						
$V_{CS(TH)}$	Cycle-by-cycle Sense Voltage Threshold	$V_{RAMP} = 0$, CSG to CS	106	120	135	mV
	CS Input Bias Current	$V_{CS} = 0V$	-100	-66		μA
	CSG Input Bias Current	$V_{CSG} = 0V$	-100	-66		μA
	Current Sense Amplifier Gain			10		V/V
	Hiccup Mode Fault Timer			256		Cycles
RES						
I_{RES}	RES Current Source			10		μA
V_{RES}	RES Threshold	RES Rising	1.22	1.25	1.285	V
Diode Emulation						
V_{IL}	DEMB Input Low Threshold			2.0	1.65	V
V_{IH}	DEMB Input High Threshold		2.95	2.5		V
	SW Zero Cross Threshold			-5		mV
	DEMB Input Pull-down Resistance			50		$k\Omega$
Current Monitor						
	Current Monitor Amplifier Gain	CS to CM	17.5	20.5	23.5	V/V
	Zero Input Offset			25	120	mV
HO Gate Driver						
V_{OHH}	HO High-state Voltage Drop	$I_{HO} = -100mA$, $V_{OHH} = V_{HB} - V_{HO}$		0.17	0.3	V
V_{OLH}	HO Low-state Voltage Drop	$I_{HO} = 100mA$, $V_{OLH} = V_{HO} - V_{SW}$		0.1	0.2	V
	HO Rise Time	C-load = 1000pF (<i>Note 7</i>)		6		ns
	HO Fall Time	C-load = 1000pF (<i>Note 7</i>)		5		ns
I_{OHH}	Peak HO Source Current	$V_{HO} = 0V$, SW = 0V, HB = 7.6V		2.2		A
I_{OLH}	Peak HO Sink Current	$V_{HO} = V_{HB} = 7.6V$		3.3		A
	HB to SW Under-voltage		2.56	2.9	3.32	V
	HB DC Bias Current	HB - SW = 7.6V		65	100	μA
LO Gate Driver						
V_{OHL}	LO High-state Voltage Drop	$I_{LO} = -100mA$, $V_{OHL} = V_{CC} - V_{LO}$		0.17	0.27	V
V_{OLL}	LO Low-state Voltage Drop	$I_{LO} = 100mA$, $V_{OLL} = V_{LO}$		0.1	0.2	V
	LO Rise Time	C-load = 1000pF (<i>Note 7</i>)		6		ns
	LO Fall Time	C-load = 1000pF (<i>Note 7</i>)		5		ns
I_{OHL}	Peak LO Source Current	$V_{LO} = 0V$		2.5		A
I_{OLL}	Peak LO Sink Current	$V_{LO} = 7.6V$		3.3		A
Switching Characteristics						
T_{DLH}	LO Fall to HO Rise Delay	No load		72		ns
	HO Fall to LO Rise Delay	No load		71		ns
Thermal						
T_{SD}	Thermal Shutdown	Temperature Rising		165		$^{\circ}C$
	Thermal Shutdown Hysteresis			25		$^{\circ}C$
θ_{JA}	Junction to Ambient	TSSOP-20EP		40		$^{\circ}C/W$

Symbol	Parameter	Conditions	Min	Typ	Max	Units
θ_{JC}	Junction to Case	TSSOP-20EP		4		°C/W
θ_{JA}	Junction to Ambient	LLP-24 (4mmx4mm)		40		°C/W
θ_{JC}	Junction to Case	LLP-24 (4mmx4mm)		6		°C/W

Note 1: Absolute Maximum Ratings are limits beyond which damage to the device may occur. Operating Ratings are conditions under which operation of the device is intended to be functional, but does not guarantee specific performance limits. For guaranteed specifications and test conditions see the Electrical Characteristics Table.

Note 2: See Application Information when input supply voltage is less than the VCC voltage.

Note 3: These pins are output pins. As such they are not specified to have an external voltage applied.

Note 4: The human body model is a 100pF capacitor discharged through a 1.5k Ω resistor into each pin.

Note 5: Minimum VIN operating voltage is defined with VCC supplied by the internal HV startup regulator and no external load on VCC. When VCC is supplied by an external source, minimum VIN operating voltage is 4.5V.

Note 6: Operating current does not include the current into the R_T resistor.

Note 7: High and low reference are 80% and 20% of the pulse amplitude respectively.

Typical Performance Characteristics

HO Peak Driver Current vs Output Voltage

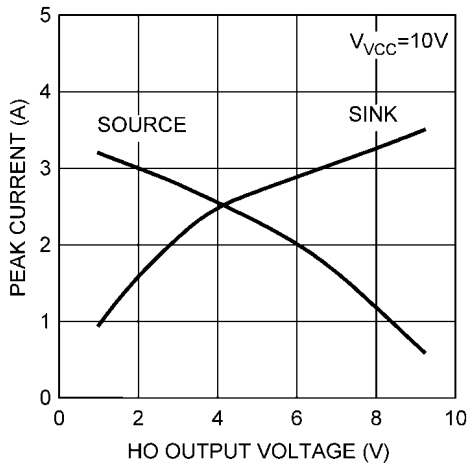

30143203

LO Peak Driver Current vs Output Voltage

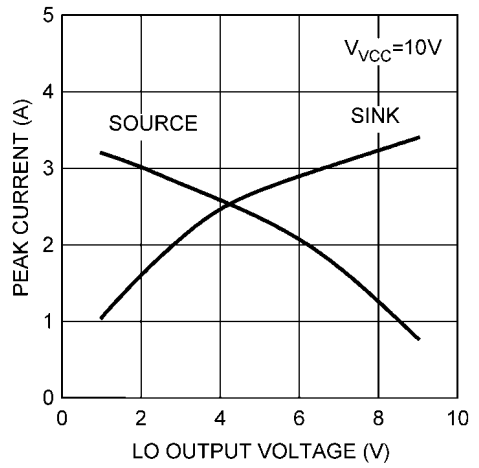

30143204

Driver Dead Time vs V_{CC}

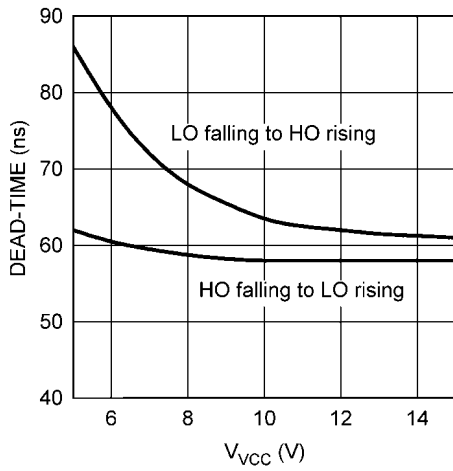

30143205

Driver Dead Time vs Temperature

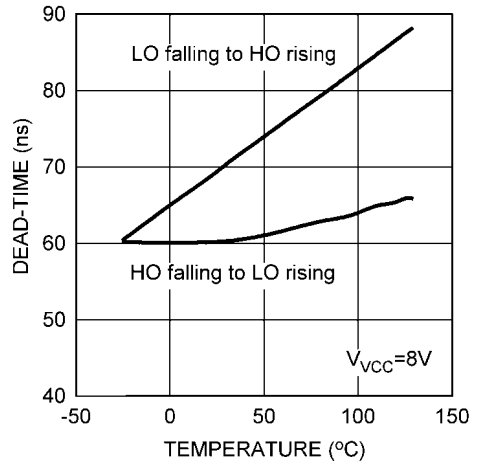

30143206

Forced HO Off-time vs Temperature

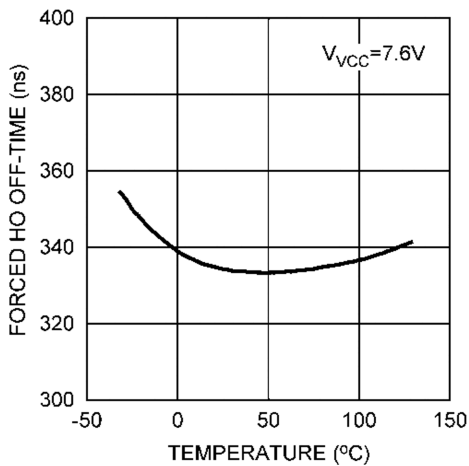

30143207

Switching Frequency vs R_T

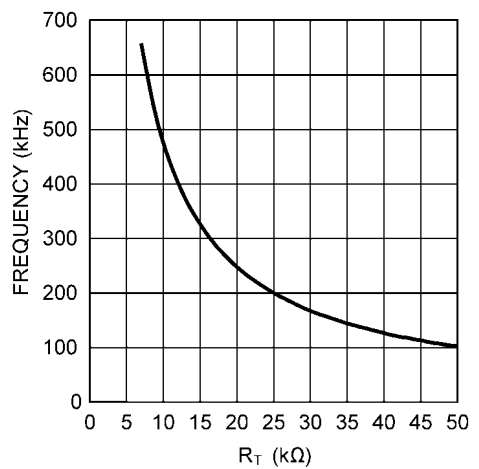

30143208

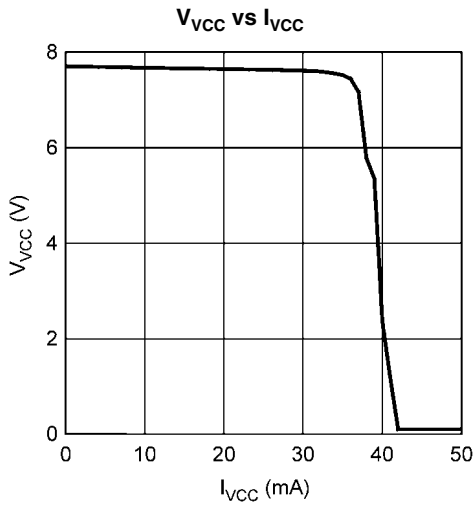

30143209

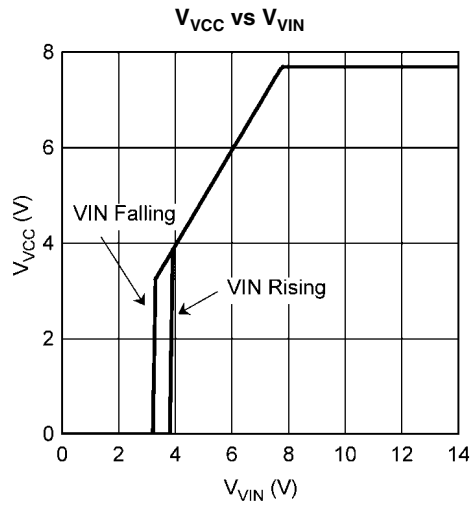

30143269

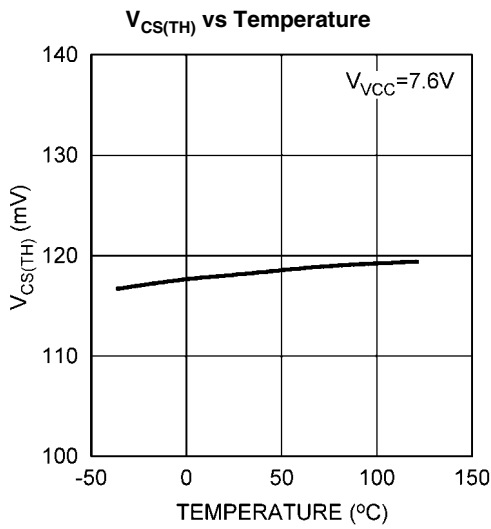

30143270

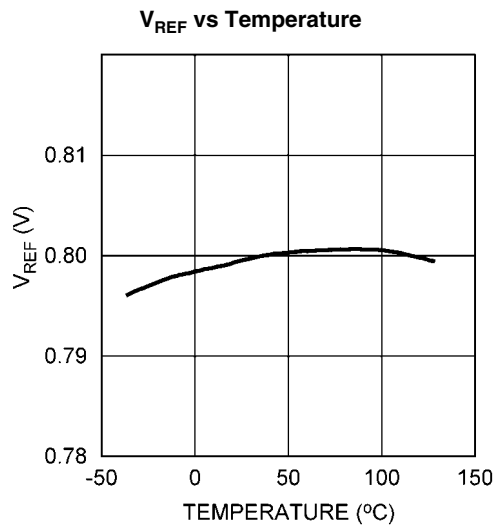

30143271

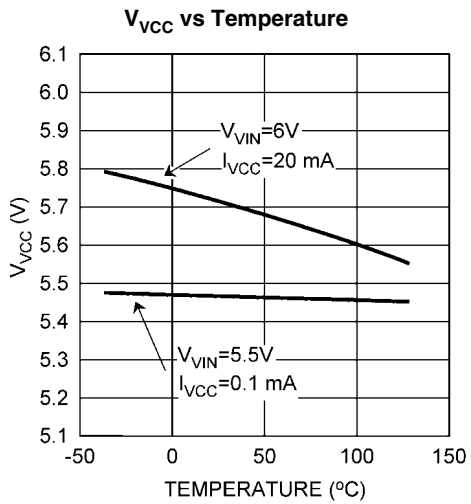

30143273

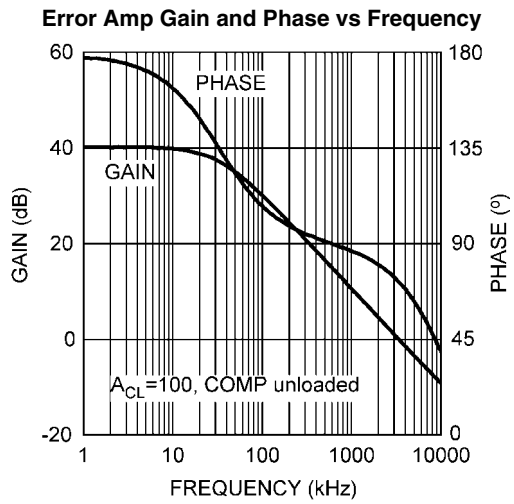

301432162

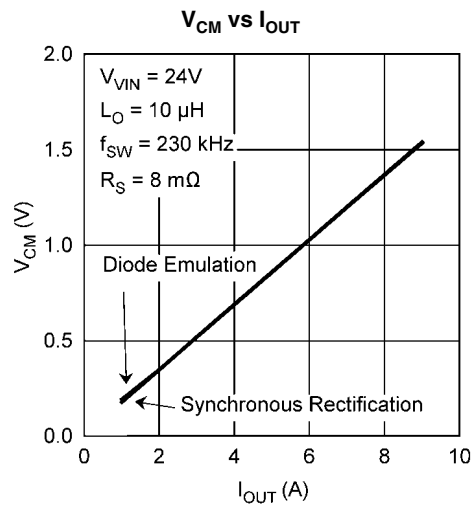

30143272

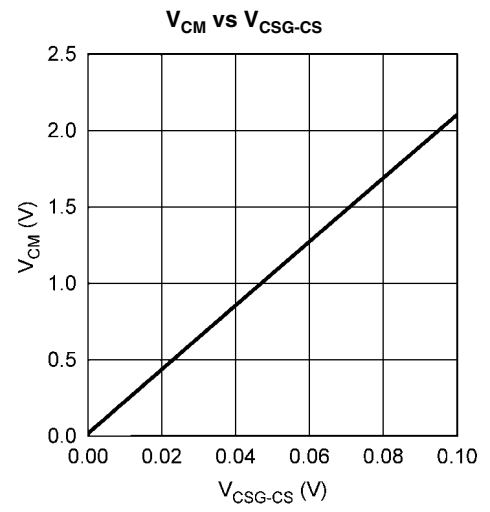

30143278

Block Diagram and Typical Application Circuit

LM5117

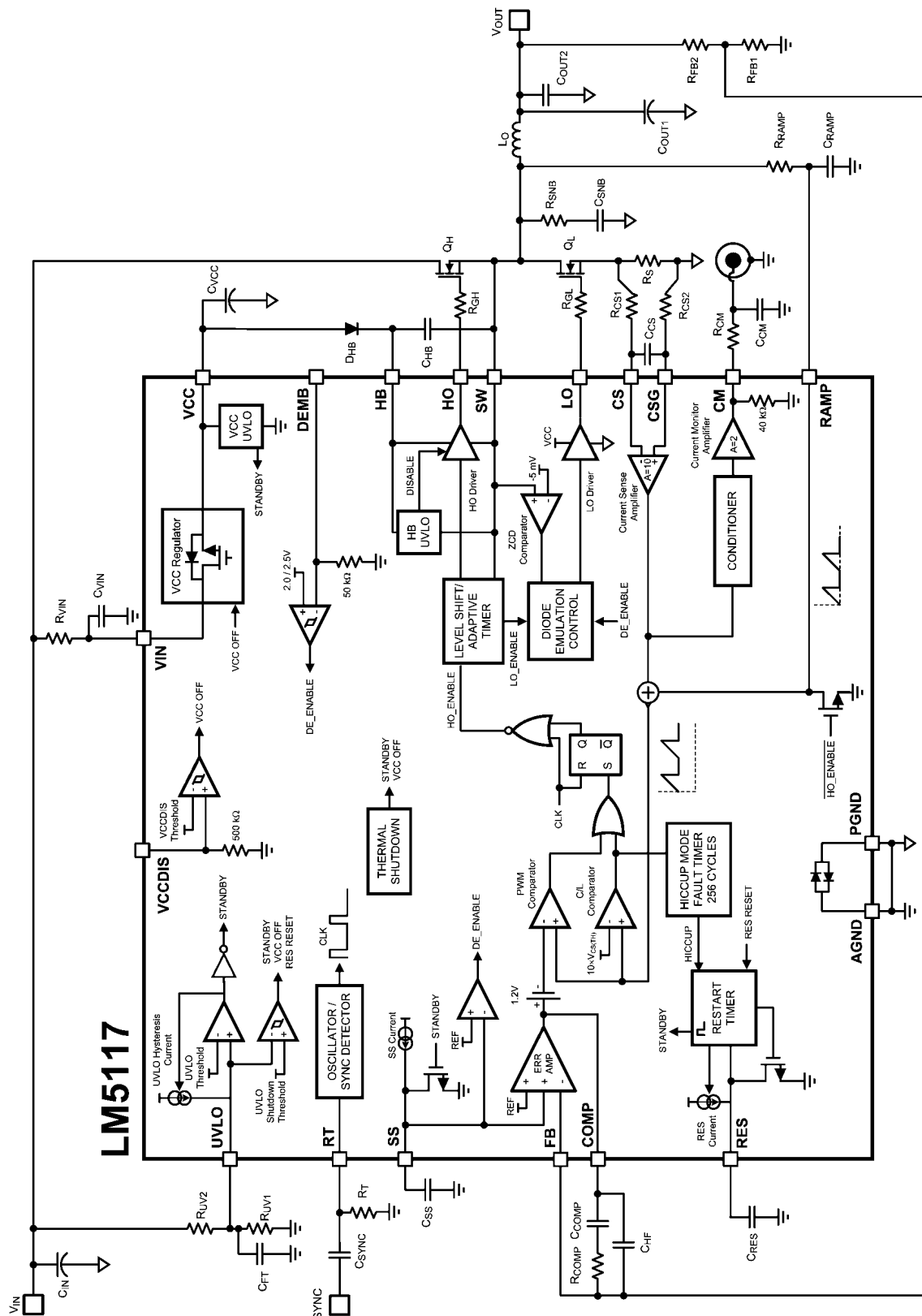

30143210

FIGURE 1. Block Diagram and Typical Application Circuit

Functional Description

The LM5117 high voltage switching controller features all of the functions necessary to implement an efficient high voltage buck regulator that operates over a very wide input voltage range. This easy to use controller integrates high-side and low-side NMOS drivers. The regulator control method is based upon peak current mode control utilizing an emulated current ramp. Peak current mode control provides inherent line feed-forward, cycle-by-cycle current limiting and ease of loop compensation. The use of an emulated control ramp reduces noise sensitivity of the PWM circuit, allowing reliable processing of the very small duty cycles necessary in high input voltage applications.

The switching frequency is user programmable up to 750 kHz. The RT pin allows the switching frequency to be programmed by a single resistor or synchronized to an external clock. Fault protection features include cycle-by-cycle and hiccup mode current limiting, thermal shutdown and remote shutdown capability by pulling down UVLO pin. The UVLO input enables the regulator when the input voltage reaches a user selected threshold and provides a very low quiescent shutdown current when pulled low. A unique analog telemetry feature provides averaged output current information, allowing various applications that need either a current monitor or current control. The functional block diagram and typical application circuit of the LM5117 are shown in *Figure 1*

The device is available in TSSOP-20EP and LLP24 package featuring an exposed pad to aid in thermal dissipation.

High Voltage Startup Regulator and VCC Disable

The LM5117 contains an internal high voltage bias regulator that provides the VCC bias supply for the PWM controller and NMOS gate drivers. The VIN pin can be connected to an input voltage source as high as 65V. The output of the VCC regulator is set to 7.6V. When the input voltage is below the VCC set-point level, the VCC output tracks the VIN with a small dropout voltage. The output of the VCC regulator is current limited at 30mA minimum.

Upon power-up, the regulator sources current into the capacitor connected to the VCC pin. The recommended capacitance range for the pin VCC is 0.47 μ F to 10 μ F. When the VCC pin voltage exceeds the VCC UV threshold and the UVLO pin is greater than UVLO threshold, the HO and LO drivers are enabled and a soft-start sequence begins. The HO and LO drivers remain enabled until either the VCC pin voltage falls below VCC UV threshold, the UVLO pin voltage falls below UVLO threshold, hiccup mode is activated or the die temperature exceeds the thermal shutdown threshold.

An output voltage derived bias supply can be applied to the VCC pin to reduce the controller power dissipation at higher input voltage. The VCCDIS input can be used to disable the internal VCC regulator when external biasing is supplied. The externally supplied bias should be coupled to the VCC pin

through a diode, preferably a Schottky diode. If the VCCDIS pin voltage exceeds the VCCDIS threshold, the internal VCC regulator is disabled. VCCDIS has a 500k Ω internal pull-down resistor to ground for normal operation with no external bias. The VCC regulator series pass transistor includes a diode between VCC (Anode) and VIN (Cathode) that should not be forward biased in normal operation. If the voltage of the external bias supply is greater than the VIN pin voltage, an external blocking diode is required from the input power supply to the VIN pin to prevent the external bias supply from passing current to the input supply through VCC.

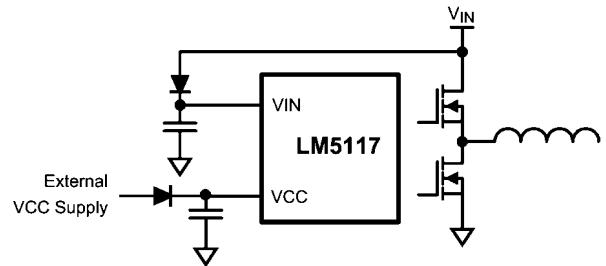

30143211

FIGURE 2. VIN Configuration for $V_{IN} < V_{VCC}$

For V_{OUT} between 6V and 14.5V, the output can be connected directly to VCC through a diode.

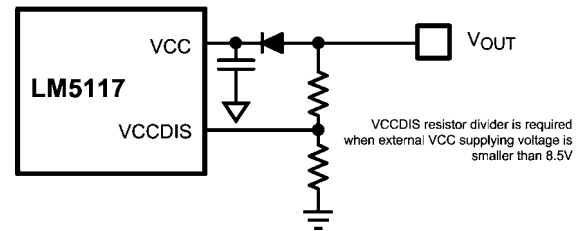

30143212

FIGURE 3. External VCC Supply for $6V < V_{OUT} < 14.5V$

For $V_{OUT} < 6V$, a bias winding on the output inductor can be added to generate the external VCC supply voltage.

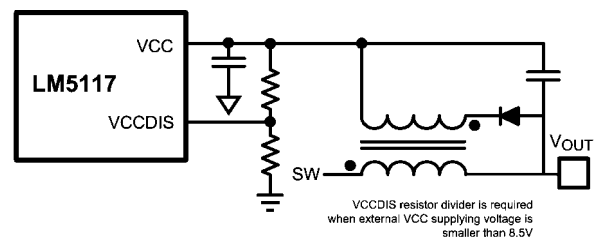

30143257

FIGURE 4. External VCC Supply for $V_{OUT} < 6V$

For $14.5V < V_{OUT}$, the external supply voltage can be regulated by using a series Zener diode from the output to VCC.

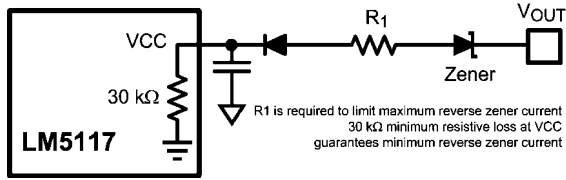

30143259

FIGURE 5. External VCC Supply for $14.5V < V_{OUT}$

In high input voltage applications, extra care should be taken to ensure the VIN pin does not exceed the absolute maximum voltage rating of 75V. During line or load transients, voltage ringing on the VIN that exceeds the Absolute Maximum Rating can damage the IC. Both careful PC board layout and the use of quality bypass capacitors located close to the VIN and AGND pin are essential. Adding an R-C filter (R_{VIN} , C_{VIN}) on VIN is optional and helps to prevent faulty operation caused by poor PC board layout and high frequency switching noise injection. The recommended capacitance and resistance range are $0.1\mu F$ to $10\mu F$ and 1Ω to 10Ω .

UVLO

The LM5117 contains a dual level UVLO (under-voltage lock-out) circuit. When the UVLO is less than $0.4V$, the LM5117 is in shutdown mode. The shutdown comparator provides $100mV$ of hysteresis to avoid chatter during transitions. When the UVLO pin voltage is greater than $0.4V$ but less than $1.25V$, the controller is in standby mode. In the standby mode, the VCC bias regulator is active but the HO and LO drivers are disabled and the SS pin is held low. This feature allows the UVLO pin to be used as a remote shutdown function by pulling the UVLO pin down below $0.4V$ with an external open collector or open drain device. When the VCC pin exceeds its under-voltage lockout threshold and the UVLO pin voltage is greater than $1.25V$, the HO and LO drivers are enabled and normal operation begins.

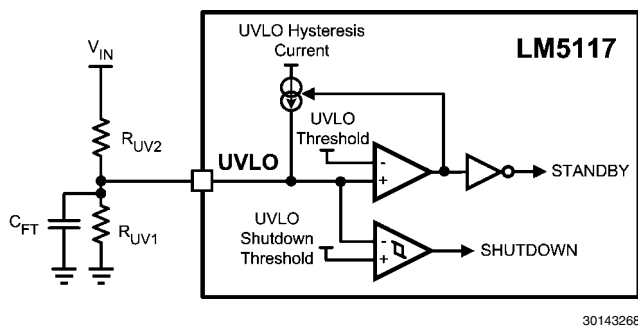

30143268

FIGURE 6. UVLO Configuration

The UVLO pin should not be left floating. An external UVLO set-point voltage divider from the VIN to AGND is used to set

the minimum input operating voltage of the regulator. The divider must be designed such that the voltage at the UVLO pin is greater than $1.25V$ and never exceeds $15V$ when the input voltage is in the desired operating range. If necessary, the UVLO pin can be clamped with a Zener diode.

UVLO hysteresis is accomplished with an internal $20\mu A$ current source that is switched on or off into the impedance of the UVLO set-point divider. When the UVLO pin voltage exceeds the $1.25V$ threshold, the current source is enabled to quickly raise the voltage at the UVLO pin. When the UVLO pin voltage falls below the $1.25V$ threshold, the current source is disabled causing the voltage at the UVLO pin to quickly fall. The use of a C_{FT} capacitor in parallel with R_{UV1} helps to minimize switching noise injection into UVLO pin, but it may slow down the falling speed of the UVLO pin when the $20\mu A$ current source is disabled. The recommended range for C_{FT} is $10pF$ to $220pF$.

The values of R_{UV1} and R_{UV2} can be determined from the following equations:

$$R_{UV2} = \frac{V_{HYS}}{20 \mu A} [\Omega] \quad (1)$$

$$R_{UV1} = \frac{1.25V \times R_{UV2}}{V_{IN(STARTUP)} - 1.25V} [\Omega] \quad (2)$$

Where V_{HYS} is the desired UVLO hysteresis and $V_{IN(STARTUP)}$ is the desired startup voltage of the regulator during turn-on.

Oscillator and Sync Capability

The LM5117 switching frequency is programmed by a single external resistor connected between the RT pin and the AGND pin. The resistor should be located very close to the device and connected directly to the RT and AGND pins. To set a desired switching frequency (f_{SW}), the resistor value can be calculated from the following equation:

$$R_T = \frac{5.2 \times 10^9}{f_{SW}} - 948 [\Omega] \quad (3)$$

The RT pin can be used to synchronize the internal oscillator to an external clock. The internal oscillator can be synchronized by AC coupling a positive edge into the RT pin. The voltage at the RT pin is nominally $1.25V$ and the voltage at the RT pin must exceed the RT Sync Positive Threshold to trip the internal synchronization pulse detector. A $5V$ amplitude pulse signal coupled through $100pF$ capacitor is a good starting point. The frequency of the external synchronization pulse is recommended to be within $\pm 10\%$ of the frequency programmed by the RT resistor but will operate to $+100\%$ of the programmed frequency. Care should be taken to guarantee that the RT pin voltage does not go below $-0.3V$ at the falling edge of the external pulse. This may limit the duty cycle of external synchronization pulse.

The R_T resistor is always required, whether the oscillator is free running or externally synchronized.

Ramp Generator and Emulated Current Sense

The ramp signal used in the pulse width modulator for traditional current mode control is typically derived directly from the high-side switch current. This switch current corresponds to the positive slope portion of the inductor current. Using this signal for the PWM ramp simplifies the control loop transfer function to a single pole response and provides inherent input voltage feed-forward compensation.

The disadvantage of using the high-side switch current signal for PWM control is the large leading edge spike due to circuit parasitics that must be filtered or blanked. Minimum achievable pulse width is limited by the filtering, blanking time and propagation delay with a high-side current sensing scheme.

In the applications where the input voltage may be relatively large in comparison to the output voltage, controlling small pulse widths and duty cycles are necessary for regulation. The LM5117 utilizes a unique ramp generator which does not actually measure the high-side switch current but rather reconstructs the signal. Representing or emulating the inductor current provides a ramp signal to the PWM comparator that is free of leading edge spikes and measurement or filtering delays, while maintaining the advantages of traditional peak current mode control.

The current reconstruction is comprised of two elements: a sample-and-hold DC level and the emulated inductor current ramp as shown in Figure 7. The sample-and-hold DC level is derived from a measurement of the recirculating current flowing through the current sense resistor. The voltage across the sense resistor is sampled and held just prior to the onset of the next conduction interval of the high-side switch. The current sense amplifier with a gain of 10 and sample-and-hold circuit provide the DC level of the reconstructed current signal as shown in Figure 8.

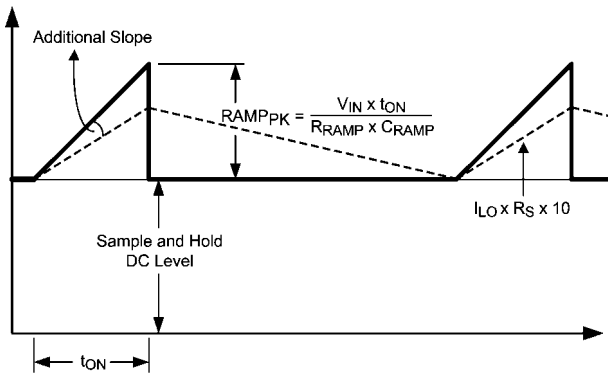
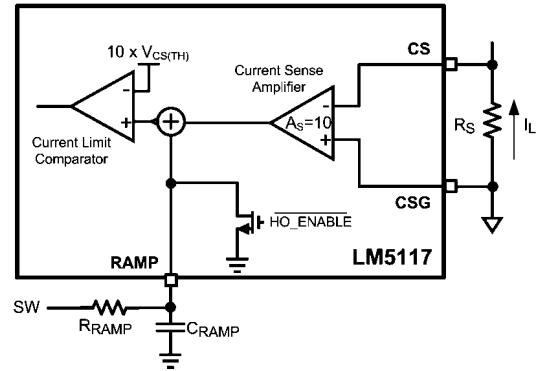

FIGURE 7. Composition of Emulated Current Sense Signal



30143213

FIGURE 8. RAMP Generator and Current Limit Circuit

The positive slope inductor current ramp is emulated by C_{RAMP} connected between RAMP and AGND and R_{RAMP} connected between SW and RAMP. R_{RAMP} should not be connected to VIN directly because the RAMP pin absolute maximum voltage rating could be exceeded under high input voltage conditions. C_{RAMP} is discharged by an internal switch during the off-time and must be fully discharged during the minimum off-time. This limits the ramp capacitor to be less than 2nF. A good quality, thermally stable ceramic capacitor is recommended for C_{RAMP} .

The selection of R_{RAMP} and C_{RAMP} can be simplified by adopting a K factor, which is defined as:

$$K = \frac{L_O}{R_{RAMP} \times C_{RAMP} \times R_S \times A_S} \quad (4)$$

Where A_S is the current sense amplifier gain which is normally 10. By choosing 1 as the K factor, the regulator removes any error after one switching cycle and the design procedure is simplified. See *Application Information* for detailed information.

Error Amplifier and PWM Comparator

The internal high-gain error amplifier generates an error signal proportional to the difference between the FB pin voltage and the internal precision 0.8V reference. The output of error amplifier is connected to the COMP pin allowing the user to provide Type 2 loop compensation components, R_{COMP} , C_{COMP} and optional C_{HF} .

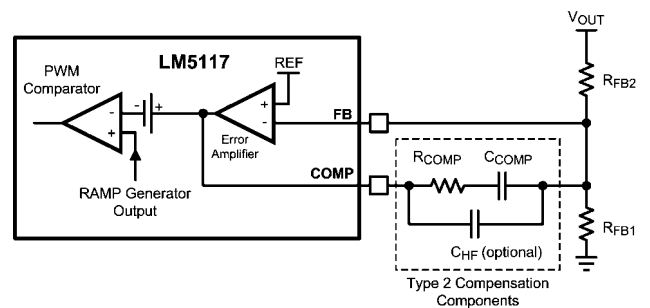

30143217

FIGURE 9. Feedback Configuration and PWM Comparator

R_{COMP} , C_{COMP} and C_{HF} configure the error amplifier gain and phase characteristics to achieve a stable voltage loop gain. This network creates a pole at DC (F_{P1}), a mid-band zero (F_Z) for phase boost, and a high frequency pole (F_{P2}). The recommended range of R_{COMP} is $2k\Omega$ to $40k\Omega$. See *Application Information* for detailed information.

$$F_{P1} = 0 \quad [\text{Hz}] \quad (5)$$

$$F_Z = \frac{1}{2\pi \times R_{COMP} \times C_{COMP}} \quad [\text{Hz}] \quad (6)$$

$$F_{P2} = \frac{1}{2\pi \times R_{COMP} \times \left(\frac{C_{COMP} \times C_{HF}}{C_{COMP} + C_{HF}} \right)} \quad [\text{Hz}] \quad (7)$$

The PWM comparator compares the emulated current sense signal from Ramp Generator to the voltage at the COMP pin through a 1.2V internal voltage drop and terminates the present cycle when the emulated current sense signal is greater than $V_{COMP} - 1.2V$.

Diode Emulation

A fully synchronous buck regulator implemented with a free-wheeling NMOS rather than a diode has the capability to sink current from the output in certain conditions such as light load, over-voltage or pre-bias startup. The LM5117 provides a diode emulation feature that can be enabled to prevent reverse current flow in the low-side NMOS device. When configured for diode emulation, the low-side NMOS driver is disabled when SW pin voltage is greater than -5mV during the off-time of the high-side NMOS driver, preventing reverse current flow.

A benefit of the diode emulation is lower power loss at no load or light load conditions. The negative effect of diode emulation is degraded light load transient response.

The diode emulation feature is configured with the DEMB pin. To enable diode emulation, connect the DEMB pin to GND or leave the pin floating. If continuous conduction operation is desired, the DEMB pin should be tied to a voltage greater than 3V and may be connected to VCC. The LM5117 forces the regulator to operate in diode emulation mode when SS pin voltage is less than the internal 0.8V reference, allowing for startup into a pre-biased load with the continuous conduction configuration.

Soft-Start

The soft-start feature allows the regulator to gradually reach the steady state operating point, thus reducing startup stresses and surges. The LM5117 regulates the FB pin to the SS pin voltage or the internal 0.8V reference, whichever is lower. The internal 10 μ A soft-start current source gradually increases the voltage on an external soft-start capacitor connected to the SS pin. This results in a gradual rise of the output voltage. Soft-start time (t_{SS}) can be calculated from the following equation:

$$t_{SS} = \frac{C_{SS} \times 0.8V}{10 \mu A} \quad [\text{sec}] \quad (8)$$

The LM5117 can track the output of a master power supply during soft-start by connecting a voltage divider from the output of master power supply to the SS pin. At the beginning of the soft-start sequence, V_{SS} should be allowed to go below 25mV by the internal SS pull-down switch. During soft-start period, when SS pin voltage is less than 0.8V, the LM5117 forces diode emulation for startup into a pre-biased load. If the tracking feature is desired, connect the DEMB pin to GND or leave the pin floating.

Cycle-by-Cycle Current Limit

The LM5117 contains a current limit monitoring scheme to protect the regulator from possible over-current conditions as shown in *Figure 8*. If the emulated ramp signal exceeds 1.2V, the present cycle is terminated. For the case where the switch current overshoots when the inductor is saturated or the output is shorted to ground, the sample-and-hold circuit detects the excess recirculating current before the high-side NMOS driver is turned on again. The high-side NMOS driver is disabled and will skip pulses until the current has decayed below the current limit threshold. This approach prevents current runaway conditions since the inductor current is forced to decay to a controlled level following any current overshoot. Maximum peak inductor current can be calculated as:

$$I_{L(\text{MAX})_PK} = \frac{V_{CS(\text{TH})}}{R_S} + I_{PP} - \frac{V_{OUT}}{f_{SW} \times A_S \times R_S \times R_{RAMP} \times C_{RAMP}} \quad [\text{A}] \quad (9)$$

$$I_{L(\text{MAX})_AVE} = I_{L(\text{MAX})_PK} - \frac{I_{PP}}{2} \quad [\text{A}] \quad (10)$$

Where I_{PP} represents inductor peak to peak ripple current in *Figure 10*, and is defined as:

$$I_{PP} = \frac{V_{OUT}}{L_O \times f_{SW}} \times \left(1 - \frac{V_{OUT}}{V_{IN}} \right) \quad [\text{A}] \quad (11)$$

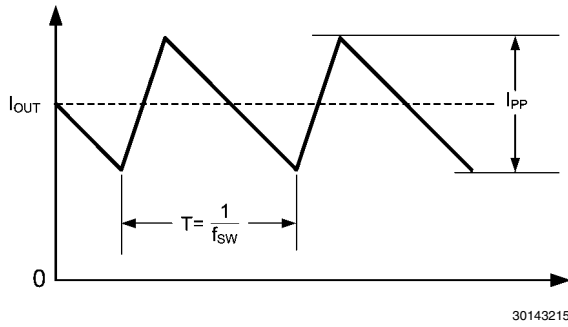

FIGURE 10. Inductor Current

During an output short condition, the worst case peak inductor current is limited to:

$$I_{LIM_PK} = \frac{V_{CS(TH)}}{R_S} + \frac{V_{IN(MAX)} \times t_{ON(MIN)}}{L_O} \text{ [A]} \quad (12)$$

Where $t_{ON(MIN)}$ is the minimum HO on-time.

If the saturation current of the inductor is less than I_{LIM_PK} , the peak inductor current during output short condition may be higher than I_{LIM_PK} . The temperatures of NMOS devices, Rs and inductor should be checked under this condition.

Hiccup Mode Current Limiting

To further protect the regulator during prolonged current limit conditions, LM5117 provides a hiccup mode current limit. An internal hiccup mode fault timer counts the PWM clock cycles during which cycle-by-cycle current limiting occurs. When the hiccup mode fault timer detects 256 consecutive cycles of current limiting, an internal restart timer forces the controller to enter a low power dissipation standby mode and starts sourcing $10\mu\text{A}$ current into the RES pin capacitor C_{RES} . In this standby mode, HO and LO outputs are disabled and the soft-start capacitor C_{SS} is discharged.

C_{RES} is connected from RES pin to AGND and determines the time (t_{RES}) in which the LM5117 remains in the standby before automatically restarting. When the RES pin voltage exceeds the 1.25V RES threshold, RES capacitor is discharged and a soft-start sequence begins. t_{RES} can be calculated from the following equation:

$$t_{RES} = \frac{C_{RES} \times 1.25V}{10 \mu\text{A}} \text{ [sec]} \quad (13)$$

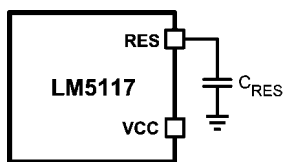

(a) Hiccup Mode Current Limit

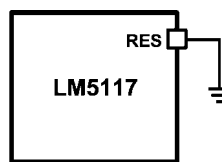

(b) Latch-off Mode Current Limit

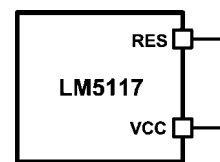

(c) Cycle-by-cycle Current Limit

30143220

FIGURE 13. RES Configurations

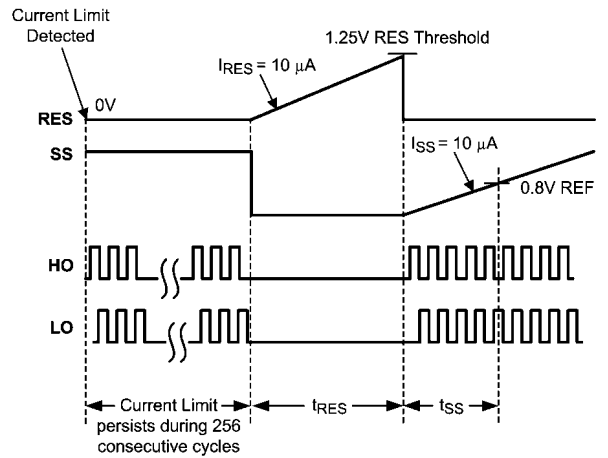

FIGURE 11. Hiccup Mode Current Limit Timing Diagram

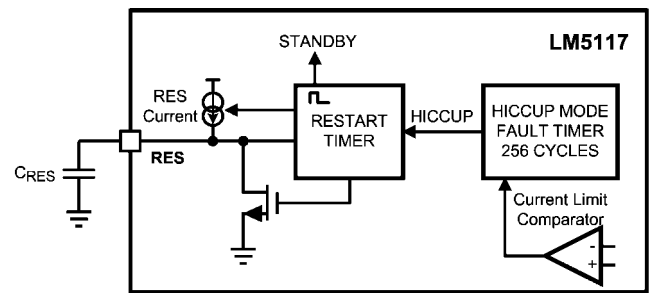

FIGURE 12. Hiccup Mode Current Limit Circuit

The RES pin can also be configured for latch-off mode current limiting or non-hiccup mode cycle-by-cycle current limiting. If the RES pin is tied to VCC or a voltage greater than the RES threshold at initial power-on, the restart timer is disabled and the regulator operates with non-hiccup mode cycle-by-cycle current limit. If the RES pin is tied to GND, the regulator enters into the standby mode after 256 consecutive cycles of current limiting and then never restarts until UVLO shutdown is cycled. The restart timer is configured during initial power-on when UVLO is above the UVLO threshold and VCC is above the VCC UV threshold.

HO and LO Drivers

The LM5117 contains high current NMOS drivers and an associated high-side level shifter to drive the external high-side NMOS device. This high-side gate driver works in conjunction with an external diode D_{HB} , and bootstrap capacitor C_{HB} . A 0.1 μF or larger ceramic capacitor, connected with short traces between the HB and SW pin, is recommended. During the off-time of the high-side NMOS driver, the SW pin voltage is approximately 0V and the C_{HB} is charged from VCC through the D_{HB} . When operating with a high PWM duty cycle, the high-side NMOS device is forced off each cycle for 320ns to ensure that C_{HB} is recharged.

The LO and HO outputs are controlled with an adaptive dead-time methodology which insures that both outputs are never enabled at the same time. When the controller commands HO to be enabled, the adaptive dead-time logic first disables LO and waits for the LO voltage to drop. HO is then enabled after a small delay (LO Fall to HO Rise Delay). Similarly, the LO turn-on is delayed until the HO voltage has discharged. LO is then enabled after a small delay (HO Fall to LO Rise Delay). This technique insures adequate dead-time for any size NMOS device, especially when VCC is supplied by a higher external voltage source. The adaptive dead-time circuitry monitors the voltages of HO and LO outputs and insures the dead-time between the HO and LO outputs. Adding a gate resistor, R_{GH} or R_{GL} , may decrease the effective dead-time.

Care should be exercised in selecting an output NMOS device with the appropriate threshold voltage, especially if VCC is supplied by an external bias supply voltage below the VCC regulation level. During startup at low input voltages, the low-side NMOS device gate plateau voltage should be lower than the VCC under-voltage lockout threshold. Otherwise, there may be insufficient VCC voltage to completely enhance the NMOS device as the VCC under-voltage lockout is released during startup. If the high-side NMOS drive voltage is lower than the high-side NMOS device gate plateau voltage during startup, the regulator may not start or it may hang up momentarily in a high power dissipation state. This condition can be addressed by selecting an NMOS device with a lower threshold voltage. This situation can be avoided if the minimum input voltage programmed by the UVLO resistor is above the VCC regulation level.

Current Monitor

The LM5117 provides average output current information, enabling various applications requiring monitoring or control of the output current.

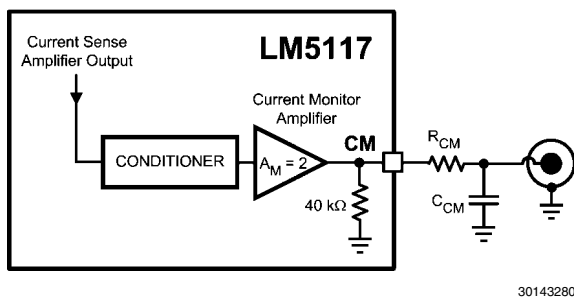

FIGURE 14. Current Monitor

The average of CM output can be calculated by:

$$V_{CM_AVE} = (I_{PEAK} + I_{VALLEY}) \times R_S \times A_S \quad [V] \quad (14)$$

The current monitor output is only valid in continuous conduction operation. The current monitor has a limited bandwidth of approximately one tenth of f_{SW} . Adding an R-C filter, R_{CM} and C_{CM} , on the output of current monitor with the cut off frequency below one tenth of f_{SW} is recommended to attenuate sampling noise.

Maximum Duty Cycle

When operating with a high PWM duty cycle, the high-side NMOS device is forced off each cycle for 320ns to ensure that C_{HB} is recharged and to allow time to sample and hold the current in the low-side NMOS FET. This forced off-time limits the maximum duty cycle of the controller. When designing a regulator with high switching frequency and high duty cycle requirements, a check should be made of the required maximum duty cycle against the graph shown in Figure 15. The actual maximum duty cycle varies with the switching frequency as follows:

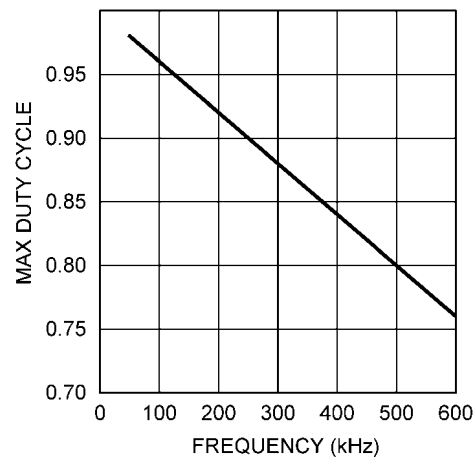

30143214

FIGURE 15. Maximum Duty Cycle vs Switching Frequency

Thermal Protection

Internal thermal shutdown circuitry is provided to protect the controller in the event the maximum junction temperature is exceeded. When activated, typically at 165°C, the controller is forced into a low power shutdown mode, disabling the output drivers and the VCC regulator. This feature is designed to prevent overheating and destroying the device.

Application Information

FEEDBACK COMPENSATION

Open loop response of the regulator is defined as the product of modulator transfer function and feedback transfer function. When plotted on a dB scale, the open loop gain is shown as the sum of modulator gain and feedback gain.

The modulator transfer function includes a power stage transfer function with an embedded current loop and can be simplified as one pole and one zero system as shown in equation (15).

$$\frac{\hat{V}_{OUT}}{\hat{V}_{COMP}} = A_M \times \frac{1 + \frac{s}{\omega_{Z_ESR}}}{\left(1 + \frac{s}{\omega_{P_LF}}\right)} \quad (15)$$

$$\text{Where } A_M \text{ (Modulator DC gain)} = \frac{R_{LOAD}}{R_S \times A_S},$$

$$\omega_{Z_ESR} \text{ (ESR zero)} = \frac{1}{R_{ESR} \times C_{OUT}},$$

$$\omega_{P_LF} \text{ (Load pole)} = \frac{1}{R_{LOAD} \times C_{OUT}}$$

If the ESR of C_{OUT} (R_{ESR}) is very small, the modulator transfer function can be further simplified to a one pole system and the voltage loop can be closed with only two loop compensation components, R_{COMP} and C_{COMP} , leaving a single pole response at the crossover frequency. A single pole response at the crossover frequency yields a very stable loop with 90 degrees of phase margin.

The feedback transfer function includes the feedback resistor divider and loop compensation of the error amplifier. R_{COMP} , C_{COMP} and optional C_{HF} configure the error amplifier gain and phase characteristics and create a pole at origin, a low frequency zero and a high frequency pole. This is shown mathematically in equation (16).

$$-\frac{\hat{V}_{COMP}}{\hat{V}_{OUT}} = A_{FB} \times \frac{1 + \frac{s}{\omega_{Z_EA}}}{s \times \left(1 + \frac{s}{\omega_{P_EA}}\right)} \quad (16)$$

$$\text{Where } A_{FB} \text{ (Feedback DC gain)} = \frac{1}{R_{FB2} \times (C_{COMP} + C_{HF})},$$

$$\omega_{Z_EA} \text{ (Low frequency zero)} = \frac{1}{R_{COMP} \times C_{COMP}},$$

$$\omega_{P_EA} \text{ (High frequency pole)} = \frac{1}{R_{COMP} \times C_{HF}}$$

The pole at the origin minimizes output steady state error. The low frequency zero should be placed to cancel the load pole of the modulator. The high frequency pole can be used to cancel the zero created by the output capacitor ESR or to decrease noise susceptibility of the error amplifier. By placing the low frequency zero an order of magnitude less than the crossover frequency, the maximum amount of phase boost can be achieved at the crossover frequency. The high frequency pole should be placed well beyond the crossover frequency since the addition of C_{HF} adds a pole in the feedback transfer function.

The crossover frequency (loop bandwidth) is usually selected between one twentieth and one fifth of the f_{SW} . In a simplified formula, the crossover frequency can be defined as:

$$f_{CROSS} = \frac{R_{COMP}}{2 \times \pi \times R_S \times R_{FB2} \times A_S \times C_{OUT}} \text{ [Hz]} \quad (17)$$

For higher crossover frequency, R_{COMP} can be increased, while proportionally decreasing C_{COMP} . Conversely, decreasing R_{COMP} while proportionally increasing C_{COMP} , results in lower bandwidth while keeping the same zero frequency in the feedback transfer function.

The sampled gain inductor pole is inversely proportional to the K factor, which is defined as:

$$\omega_{P_HF} = \frac{f_{SW}}{K - 0.5} \quad (18)$$

The maximum achievable loop bandwidth, in fact, is limited by this sampled gain inductor pole. In traditional current mode control, the maximum achievable loop bandwidth varies with input voltage. With the LM5117's unique slope compensation scheme, the sampled gain inductor pole is independent of changes to the input voltage. This frees the user from additional concerns in wide varying input range applications and is an advantage of the LM5117.

If the sampled gain inductor pole or the ESR zero is close to the crossover frequency, it is recommended that the comprehensive formulas in [Table 1](#) be used and the stability should be checked by a network analyzer. The modulator transfer function can be measured and the feedback transfer function can be configured for the desired open loop transfer function. If a network analyzer is not available, step load transient tests can be performed to verify acceptable performance. The step load goal is minimum overshoot/undershoot with a damped response.

SUB-HARMONIC OSCILLATION

Peak current mode regulators can exhibit unstable behavior when operating above 50% duty cycle. This behavior is known as sub-harmonic oscillation and is characterized by alternating wide and narrow pulses at the SW pin. Sub-harmonic oscillation can be prevented by adding an additional voltage ramp (slope compensation) on top of the sensed inductor current shown in *Figure 7*. By choosing $K \geq 1$, the regulator will not be subject to sub-harmonic oscillation caused by a varying input voltage.

In time-domain analysis, the steady-state inductor current starts and ends at the same value during one clock cycle. If the magnitude of the end-of-cycle current error, dl_1 , caused by an initial perturbation, dl_0 , is less than the magnitude of dl_0 or $dl_1/dl_0 > -1$, the perturbation naturally disappears after a few cycles. When $dl_1/dl_0 < -1$, the initial perturbation does not disappear, resulting in sub-harmonic oscillation in steady-state operation.

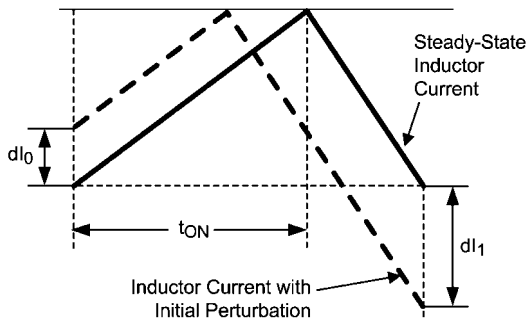

30143281

FIGURE 16. Effect of Initial Perturbation when $dl_1/dl_0 < -1$

dl_1/dl_0 can be calculated by:

$$\frac{dl_1}{dl_0} = 1 - \frac{1}{K} \tag{19}$$

The relationship between dl_1/dl_0 and K factor is illustrated graphically in *Figure 17*.

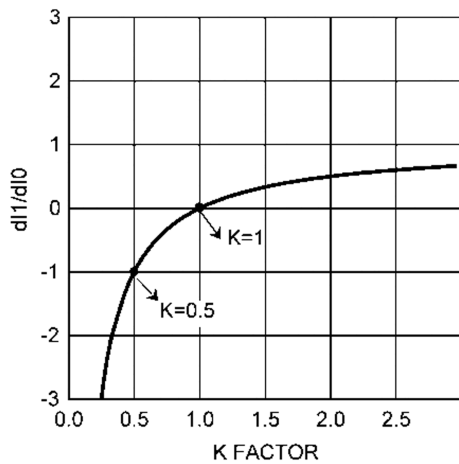

30143276

FIGURE 17. dl_1/dl_0 vs K Factor

The minimum value of K is 0.5. When $K < 0.5$, the amplitude of dl_1 is greater than the amplitude of dl_0 and any initial per-

turbation results in sub-harmonic oscillation. If $K=1$, any initial perturbation will be removed in one switching cycle. This is known as one-cycle damping. When $-1 < dl_1/dl_0 < 0$, any initial perturbation will be under-damped. Any perturbation will be over-damped when $0 < dl_1/dl_0 < 1$.

In the frequency-domain, Q, the quality factor of the sampling gain term in the modulator transfer function, is used to predict the tendency for sub-harmonic oscillation, which is defined as:

$$Q = \frac{1}{\pi(K-0.5)} \tag{20}$$

The relationship between Q and K factor is illustrated graphically in *Figure 18*.

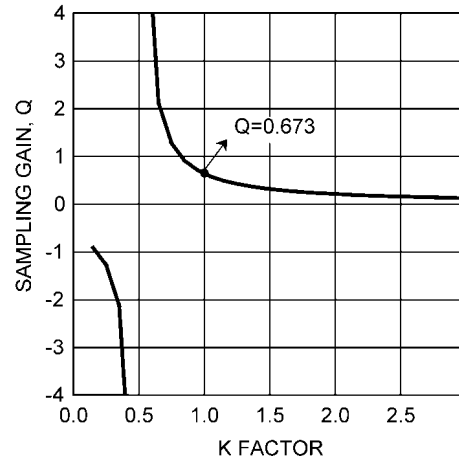

30143277

FIGURE 18. Sampling gain Q vs K Factor

The minimum value of K is 0.5 again. This is the same as time domain analysis result. When $K < 0.5$, the regulator is unstable. High gain peaking at 0.5 results in sub-harmonic oscillation at $F_{SW}/2$. When $K=1$, one-cycle damping is realized. Q is equal to 0.673 at this point. A higher K factor may introduce additional phase shift by moving the sampled gain inductor pole closer to the crossover frequency, but will help reduce noise sensitivity in the current loop. The maximum allowable value of K factor can be calculated by the Maximum Crossover Frequency equation in *Table 1*.

PC BOARD LAYOUT RECOMMENDATION

In a buck regulator the primary switching loop consists of the input capacitor, NMOS power switches and current sense resistor. Minimizing the area of this loop reduces the stray inductance and minimizes noise and possible erratic operation. High quality input capacitors should be placed as close as possible to the NMOS power switches, with the V_{IN} side of the capacitor connected directly to the high-side NMOS drain and the ground side of the capacitor connected as close as possible to the current sense resistor ground connection.

Connect all of the low power ground connections (R_{UV1} , R_T , R_{FB1} , C_{SS} , C_{RES} , C_{CM} , C_{VIN} , C_{RAMP}) directly to the regulator AGND pin. Connect C_{VCC} directly to the regulator PGND pin. Note that C_{VIN} and C_{VCC} must be as physically close as possible to the IC. AGND and PGND must be directly connected together through a top-side copper pattern connected to the exposed pad. Ensure no high current flows beneath the underside exposed pad.

The LM5117 has an exposed thermal pad to aid power dissipation. Adding several vias under the exposed pad helps conduct heat away from the IC. The junction to ambient thermal resistance varies with application. The most significant variables are the area of copper in the PC board, the number of vias under the exposed pad and the amount of forced air

cooling. The integrity of the solder connection from the IC exposed pad to the PC board is critical. Excessive voids greatly decrease the thermal dissipation capacity.

The highest power dissipating components are the two power switches. Selecting NMOS switches with exposed pads aids the power dissipation of these devices.

TABLE 1. LM5117 Frequency Analysis Formulas

	SIMPLE FORMULA	COMPREHENSIVE FORMULA*
MODULATOR TRANSFER FUNCTION	$\frac{\hat{V}_{OUT}}{\hat{V}_{COMP}} = A_M \times \frac{1 + \frac{s}{\omega_{Z_ESR}}}{\left(1 + \frac{s}{\omega_{P_LF}}\right)}$	$\frac{\hat{V}_{OUT}}{\hat{V}_{COMP}} = A_M \times \frac{1 + \frac{s}{\omega_{Z_ESR}}}{\left(1 + \frac{s}{\omega_{P_LF}}\right) \times \left(1 + \frac{s}{\omega_{P_ESR}}\right) \times \left(1 + \frac{s}{\omega_{P_HF}} + \frac{s^2}{\omega_n^2}\right)}$
Modulator DC Gain	$A_M = \frac{R_{LOAD}}{R_S \times A_S}$	$A_M = \frac{R_{LOAD}}{R_S \times A_S} \times \frac{1}{1 + \frac{R_{LOAD}}{\omega_{P_HF} \times L_O}}$
ESR Zero	$\omega_{Z_ESR} = \frac{1}{R_{ESR} \times C_{OUT}}$	$\omega_{Z_ESR} = \frac{1}{R_{ESR1} \times C_{OUT1}}$
ESR Pole	Not considered	$\omega_{P_ESR} = \frac{1}{R_{ESR1} \times (C_{OUT1} // C_{OUT2})}$
Dominant Load Pole	$\omega_{P_LF} = \frac{1}{R_{LOAD} \times C_{OUT}}$	$\omega_{P_LF} = \frac{1}{(R_{LOAD} + R_{ESR1}) \times (C_{OUT1} + C_{OUT2})} + \frac{1}{L_O \times (C_{OUT1} + C_{OUT2}) \times \omega_{P_HF}}$
Sampled Gain Inductor Pole	Not considered	$\omega_{P_HF} = \frac{f_{SW}}{K - 0.5} \quad \text{or} \quad \omega_{P_HF} = Q \times \omega_n$
Quality Factor	Not considered	$Q = \frac{1}{\pi(K - 0.5)}$
Sub-harmonic Double Pole	Not considered	$\omega_n = \frac{\omega_{SW}}{2} = \pi \times f_{SW} \quad \text{or} \quad f_n = \frac{f_{SW}}{2}$
K Factor	$K = 1$	$K = \frac{L_O}{R_{RAMP} \times C_{RAMP} \times R_S \times A_S}$
FEEDBACK TRANSFER FUNCTION	$-\frac{\hat{V}_{COMP}}{\hat{V}_{OUT}} = A_{FB} \times \frac{1 + \frac{s}{\omega_{Z_EA}}}{s \times \left(1 + \frac{s}{\omega_{P_EA}}\right)}$	$-\frac{\hat{V}_{COMP}}{\hat{V}_{OUT}} = A_{FB} \times \frac{1 + \frac{s}{\omega_{Z_EA}}}{s \times \left(1 + \frac{s}{\omega_{P_EA}}\right)}$
Feedback DC Gain	$A_{FB} = \frac{1}{R_{FB2} \times (C_{COMP} + C_{HF})}$	$A_{FB} = \frac{1}{R_{FB2} \times (C_{COMP} + C_{HF})}$
Mid-band Gain	$A_{FB_MID} = \frac{R_{COMP}}{R_{FB2}}$	$A_{FB_MID} = \frac{R_{COMP}}{R_{FB2}}$
Low Frequency Zero	$\omega_{Z_EA} = \frac{1}{R_{COMP} \times C_{COMP}}$	$\omega_{Z_EA} = \frac{1}{R_{COMP} \times C_{COMP}}$
High Frequency Pole	$\omega_{P_EA} = \frac{1}{R_{COMP} \times C_{HF}}$	$\omega_{P_EA} = \frac{1}{R_{COMP} \times (C_{HF} // C_{COMP})}$
OPEN-LOOP RESPONSE	$T(s) = A_M \times A_{FB} \times \frac{1 + \frac{s}{\omega_{Z_ESR}}}{\left(1 + \frac{s}{\omega_{P_LF}}\right)} \times \frac{1 + \frac{s}{\omega_{Z_EA}}}{s \times \left(1 + \frac{s}{\omega_{P_EA}}\right)}$ $T(s) = \frac{A_M \times A_{FB}}{s}$ when $\omega_{Z_EA} = \omega_{P_LF}$ & $\omega_{P_EA} = \omega_{Z_ESR}$	$T(s) = A_M \times A_{FB} \times \frac{1 + \frac{s}{\omega_{Z_ESR}}}{\left(1 + \frac{s}{\omega_{P_LF}}\right) \times \left(1 + \frac{s}{\omega_{P_ESR}}\right) \times \left(1 + \frac{s}{\omega_{P_HF}} + \frac{s^2}{\omega_n^2}\right)} \times \frac{1 + \frac{s}{\omega_{Z_EA}}}{s \times \left(1 + \frac{s}{\omega_{P_EA}}\right)}$ $T(s) = \frac{A_M \times A_{FB}}{s} \times \frac{1 + \frac{s}{\omega_{Z_ESR}}}{\left(1 + \frac{s}{\omega_{P_EA}}\right) \times \left(1 + \frac{s}{\omega_{P_ESR}}\right) \times \left(1 + \frac{s}{\omega_{P_HF}} + \frac{s^2}{\omega_n^2}\right)}$ when $\omega_{Z_EA} = \omega_{P_LF}$

	SIMPLE FORMULA	COMPREHENSIVE FORMULA*
Cross Over Frequency (Open Loop Bandwidth)	$f_{\text{CROSS}} = \frac{R_{\text{COMP}}}{2 \times \pi \times R_{\text{S}} \times R_{\text{FB2}} \times A_{\text{S}} \times C_{\text{OUT}}}$ <p>when $\omega_{\text{Z}_{\text{EA}}} = \omega_{\text{P}_{\text{LF}}}$ & $\omega_{\text{P}_{\text{EA}}} = \omega_{\text{Z}_{\text{ESR}}}$</p>	$f_{\text{CROSS}} = \frac{R_{\text{COMP}}}{2 \times \pi \times R_{\text{S}} \times R_{\text{FB2}} \times A_{\text{S}} \times (C_{\text{OUT1}} + C_{\text{OUT2}})}$ <p>when $\omega_{\text{Z}_{\text{EA}}} = \omega_{\text{P}_{\text{LF}}}$ & $\omega_{\text{P}_{\text{EA}}} = \omega_{\text{Z}_{\text{ESR}}}$</p> <p>& $f_{\text{CROSS}} < \frac{\omega_{\text{P}_{\text{HF}}}}{2 \times \pi \times 10}$ & $f_{\text{CROSS}} < \frac{\omega_{\text{P}_{\text{ESR}}}}{2 \times \pi \times 10}$</p>
Maximum Cross Over Frequency	$f_{\text{CROSS_MAX}} = \frac{f_{\text{SW}}}{5}$	$f_{\text{CROSS_MAX}} = \frac{f_{\text{SW}}}{4 \times Q} \times (\sqrt{1 + 4 \times Q^2} - 1)$ <p>The frequency at which 45° phase shift occurs in modulator phase characteristics.</p>

* Comprehensive Equation includes an inductor pole and a gain peaking at $f_{\text{SW}}/2$, which caused by sampling effect of the current mode control. Also it assumes that a ceramic capacitor C_{OUT2} (No ESR) is connected in parallel with C_{OUT1} . R_{ESR1} represents ESR of C_{OUT1} .

Design Example

OPERATING CONDITIONS

- Output Voltage $V_{OUT} = 12V$
- Full Load Current $I_{OUT} = 9A$
- Minimum Input Voltage $V_{IN(MIN)} = 15V$
- Maximum Input Voltage $V_{IN(MAX)} = 55V$
- Switching Frequency $f_{SW} = 230kHz$
- Diode Emulation Yes
- External VCC Supply Yes

TIMING RESISTOR R_T

Generally, higher frequency applications are smaller but have higher losses. Operation at 230 kHz was selected for this example as a reasonable compromise between small size and high efficiency. The value of R_T for 230 kHz switching frequency can be calculated from the equation (3) as follows:

$$R_T = \frac{5.2 \times 10^9}{230 \times 10^3} - 948 = 21.7 \text{ k}\Omega$$

A standard value of 22.1k Ω was chosen for R_T .

OUTPUT INDUCTOR L_O

The maximum inductor ripple current occurs at the maximum input voltage. Typically, 20% to 40% of the full load current is a good compromise between core loss and copper loss of the inductor. Higher ripple current allows for a smaller inductor size, but places more of a burden on the output capacitor to smooth the ripple voltage on the output. For this example, a ripple current of 40% of 9A was chosen. Knowing the switching frequency, maximum ripple current, maximum input voltage and the nominal output voltage, the inductor value can be calculated as follows:

$$L_O = \frac{V_{OUT}}{I_{PP(MAX)} \times f_{SW}} \times \left(1 - \frac{V_{OUT}}{V_{IN(MAX)}}\right) \text{ [H]}$$

$$L_O = \frac{12V}{9A \times 0.4 \times 230 \text{ kHz}} \times \left(1 - \frac{12V}{55V}\right) = 11.3 \text{ }\mu\text{H}$$

The closest standard value of 10 μ H was chosen for L_O . Using the value of 10 μ H for L_O , calculate I_{PP} again. This step is necessary if the chosen value of L_O differs significantly from the calculated value.

From the equation (11),

$$I_{PP(MAX)} = \frac{12V}{10 \text{ }\mu\text{H} \times 230 \text{ kHz}} \times \left(1 - \frac{12V}{55V}\right) = 4.1A$$

At the minimum input voltage, this value is 1.04A

DIODE EMULATION FUNCTION

The DEMB pin is left floating since this example uses diode emulation to reduce the power loss under no load or light load conditions.

CURRENT SENSE RESISTOR R_S

The performance of the converter will vary depending on the K value. For this example, K=1 was chosen to control sub-harmonic oscillation and achieve one-cycle damping. The maximum output current capability ($I_{OUT(MAX)}$) should be 20~50% higher than the required output current, to account for tolerances and ripple current. For this example, 130% of 9A was chosen. The current sense resistor value can be calculated from the equation (9), (10) as follows:

$$R_S = \frac{V_{CS(TH)}}{I_{OUT(MAX)} + \frac{V_{OUT} \times K}{f_{SW} \times L_O} - \frac{I_{PP}}{2}} \text{ [\Omega]}$$

$$R_S = \frac{0.12V}{9A \times 1.3 + \frac{12 \times 1}{230 \text{ kHz} \times 10 \text{ }\mu\text{H}} - \frac{1.04A}{2}} = 7.3 \text{ m}\Omega$$

A value of 7.41m Ω was realized for R_S by placing an additional 0.1 Ω sense resistor in parallel with 8m Ω . The sense resistor must be rated to handle the power dissipation at maximum input voltage when current flows through the low-side NMOS for the majority of the PWM cycle. The maximum power dissipation of R_S can be calculated as:

$$P_{RS} = \left(1 - \frac{V_{OUT}}{V_{IN(MAX)}}\right) \times I_{OUT}^2 \times R_S \text{ [W]}$$

$$P_{RS} = \left(1 - \frac{12V}{55V}\right) \times 9A^2 \times 7.41 \text{ m}\Omega = 0.47W$$

The worst case peak inductor current under the output short condition can be calculated from the equation (12) as follows:

$$I_{LIM_PK} = \frac{0.12V}{7.41 \text{ m}\Omega} + \frac{55V \times 100 \text{ ns}}{10 \text{ }\mu\text{H}} = 16.7A$$

Where $t_{ON(MIN)}$ is normally 100ns.

CURRENT SENSE FILTER R_{CS} and C_{CS}

The LM5117 itself is not affected by the large leading edge spike because it samples valley current just prior to the onset of the high-side switch. A current sense filter is used to minimize a noise injection from any external noise sources. In general, a current sense filter is not necessary. In this example, a current sense filter is not used

RAMP RESISTOR R_{RAMP} and RAMP CAPACITOR C_{RAMP}

The positive slope of the inductor current ramp signal is emulated by R_{RAMP} and C_{RAMP} . For this example, the value of C_{RAMP} was set at the standard capacitor value of 820pF. With the inductor, sense resistor and the K factor selected, the value of R_{RAMP} can be calculated from the equation (4) as follows:

$$R_{RAMP} = \frac{L_O}{K \times C_{RAMP} \times R_S \times A_S} \text{ [\Omega]}$$

$$R_{\text{RAMP}} = \frac{10 \mu\text{H}}{1 \times 820 \text{ pF} \times 7.41 \text{ m}\Omega \times 10} = 165 \text{ k}\Omega$$

The standard value of 165 k Ω was selected for R_{RAMP} .

UVLO DIVIDER R_{UV2} , R_{UV1} AND C_{FT}

The desired startup voltage and the hysteresis are set by the voltage divider R_{UV1} and R_{UV2} . Capacitor C_{FT} provides filtering for the divider. For this design, the startup voltage was set to 14V, 1V below $V_{\text{IN(MIN)}}$. V_{HYS} was set to 2V. The value of R_{UV1} , R_{UV2} can be calculated from equations (1) and (2) as follows:

$$R_{\text{UV2}} = \frac{2\text{V}}{20 \mu\text{A}} = 100 \text{ k}\Omega$$

$$R_{\text{UV1}} = \frac{1.25\text{V} \times 100 \text{ k}\Omega}{14\text{V} - 1.25\text{V}} = 9.8 \text{ k}\Omega$$

The standard value of 100k Ω was selected for R_{UV2} . R_{UV1} was selected to be 9.76k Ω . A value of 47pF was chosen for C_{FT} .

VCC DISABLE AND EXTERNAL VCC SUPPLY

The 12V output voltage allows the external VCC supply configuration as shown in [Figure 3](#). In this example, VCCDIS can be left floating since V_{OUT} is higher than VCC regulator set-point level.

POWER SWITCHES Q_{H} and Q_{L}

Selection of the power NMOS devices is governed by the same trade-offs as switching frequency. Breaking down the losses in the high-side and low-side NMOS devices is one way to compare the relative efficiencies of different devices. Losses in the power NMOS devices can be broken down into conduction loss, gate charging loss, and switching loss.

Conduction loss P_{DC} is approximately:

$$P_{\text{DC (High-Side)}} = D \times (I_{\text{OUT}}^2 \times R_{\text{DS(ON)}} \times 1.3) \quad [\text{W}]$$

$$P_{\text{DC (Low-Side)}} = (1 - D) \times (I_{\text{OUT}}^2 \times R_{\text{DS(ON)}} \times 1.3) \quad [\text{W}]$$

Where D is the duty cycle and the factor of 1.3 accounts for the increase in the NMOS device on-resistance due to heating. Alternatively, the factor of 1.3 can be eliminated and the high temperature on-resistance of the NMOS device can be estimated using the $R_{\text{DS(ON)}}$ vs Temperature curves in the MOSFET datasheet.

Gate charging loss (P_{GC}) results from the current driving the gate capacitance of the power NMOS devices and is approximated as:

$$P_{\text{GC}} = n \times V_{\text{VCC}} \times Q_{\text{g}} \times f_{\text{SW}} \quad [\text{W}]$$

Q_{g} refers to the total gate charge of an individual NMOS device, and 'n' is the number of NMOS devices. Gate charge loss differs from conduction and switching losses in that the actual dissipation occurs in the controller IC. Switching loss (P_{SW}) occurs during the brief transition period as the high-side NMOS device turns on and off. During the transition period both current and voltage are present in the channel of the NMOS device. The switching loss can be approximated as:

$$P_{\text{SW}} = 0.5 \times V_{\text{IN}} \times I_{\text{OUT}} \times (t_{\text{R}} + t_{\text{F}}) \times f_{\text{SW}} \quad [\text{W}]$$

t_{R} and t_{F} are the rise and fall times of the high-side NMOS device. The rise and fall times are usually mentioned in the MOSFET datasheet or can be empirically observed with an oscilloscope. Switching loss is calculated for the high-side NMOS device only. Switching loss in the low-side NMOS device is negligible because the body diode of the low-side NMOS device turns on before and after the low-side NMOS device switches. For this example, the maximum drain-to-source voltage applied to either NMOS device is 55V. The selected NMOS devices must be able to withstand 55V plus any ringing from drain to source and must be able to handle at least the VCC voltage plus any ringing from gate to source.

SNUBBER COMPONENTS R_{SNB} AND C_{SNB}

A resistor-capacitor snubber network across the low-side NMOS device reduces ringing and spikes at the switching node. Excessive ringing and spikes can cause erratic operation and can couple noise to the output voltage. Selecting the values for the snubber is best accomplished through empirical methods. First, make sure the lead lengths for the snubber connections are very short. Start with a resistor value between 5 and 50 Ω . Increasing the value of the snubber capacitor results in more damping, but higher snubber losses. Select a minimum value for the snubber capacitor that provides adequate damping of the spikes on the switch waveform at heavy load. A snubber may not be necessary with an optimized layout.

BOOTSTRAP CAPACITOR C_{HB} AND BOOTSTRAP DIODE D_{HB}

The bootstrap capacitor between the HB and SW pin supplies the gate current to charge the high-side NMOS device gate during each cycle's turn-on and also supplies recovery charge for the bootstrap diode. These current peaks can be several amperes. The recommended value of the bootstrap capacitor is at least 0.1 μF . C_{HB} should be a good quality, low ESR, ceramic capacitor located at the pins of the IC to minimize potentially damaging voltage transients caused by trace inductance. The absolute minimum value for the bootstrap capacitor is calculated as:

$$C_{\text{HB}} \geq \frac{Q_{\text{g}}}{\Delta V_{\text{HB}}} \quad [\text{F}]$$

Where Q_{g} is the high-side NMOS gate charge and ΔV_{HB} is the tolerable voltage droop on C_{HB} , which is typically less than 5% of VCC or 0.15V conservatively. A value of 0.47 μF was selected for this design.

VCC CAPACITOR C_{VCC}

The primary purpose of the VCC capacitor (C_{VCC}) is to supply the peak transient currents of the LO driver and bootstrap diode as well as provide stability for the VCC regulator. These peak currents can be several amperes. The recommended value of C_{VCC} should be no smaller than 0.47 μF , and should be a good quality, low ESR, ceramic capacitor. C_{VCC} should be placed at the pins of the IC to minimize potentially damaging voltage transients caused by trace inductance. A value of 1 μF was selected for this design.

OUTPUT CAPACITOR C_{O}

The output capacitors smooth the output voltage ripple caused by inductor ripple current and provide a source of charge during transient loading conditions. For this design

example, a 470 μ F electrolytic capacitor with maximum 20m Ω ESR was selected as the main output capacitor. The fundamental component of the output ripple voltage with maximum ESR is approximated as:

$$\Delta V_{OUT} = I_{PP} \times \sqrt{R_{ESR}^2 + \left(\frac{1}{8 \times f_{SW} \times C_{OUT}} \right)^2} \quad [V]$$

$$\Delta V_{OUT} = 4.1 \times \sqrt{0.02\Omega^2 + \left(\frac{1}{8 \times 230 \text{ kHz} \times 470 \mu\text{F}} \right)^2} = 82 \text{ mV}$$

Additional low ERS / ESL ceramic capacitors can be placed in parallel with the main output capacitor to further reduce the output voltage ripple and spikes. In this example, two 22 μ F capacitors were added.

INPUT CAPACITOR C_{IN}

The regulator input supply voltage typically has high source impedance at the switching frequency. Good quality input capacitors are necessary to limit the ripple voltage at the VIN pin while supplying most of the switch current during the on-time. When the high-side NMOS device turns on, the current into the device steps to the valley of the inductor current waveform, ramps up to the peak value, and then drops to the zero at turnoff. The input capacitor should be selected for RMS current rating and minimum ripple voltage. A good approximation for the required ripple current rating necessary is $I_{RMS} > I_{OUT} / 2$.

In this example, seven 3.3 μ F ceramic capacitors were used. With ceramic capacitors, the input ripple voltage will be triangular. The input ripple voltage can be approximated as:

$$\Delta V_{IN} = \frac{I_{OUT}}{4 \times f_{SW} \times C_{IN}} \quad [V]$$

$$\Delta V_{IN} = \frac{9A}{4 \times 230 \text{ kHz} \times 3.3 \mu\text{H} \times 7} = 0.42V$$

Capacitors connected in parallel should be evaluated for RMS current rating. The current will split between the input capacitors based on the relative impedance of the capacitors at the switching frequency.

VIN FILTER R_{VIN} , C_{VIN}

An R-C filter (R_{VIN} , C_{VIN}) on VIN is optional. The filter helps to prevent faults caused by high frequency switching noise injection into the VIN pin. 0.47 μ F ceramic capacitor is used for C_{VIN} in the example. R_{VIN} is selected to be 3.9 Ω

SOFT-START CAPACITOR C_{SS}

The capacitor at the SS pin (C_{SS}) determines the soft-start time (t_{SS}), which is the time for the output voltage to reach the final regulated value. The t_{SS} for a given C_{SS} can be calculated from equation (8) as follows:

$$t_{SS} = \frac{0.1 \mu\text{F} \times 0.8V}{10 \mu\text{A}} = 8 \text{ ms}$$

For this example, a value of 0.1 μ F was chosen for a soft-start time of 8ms.

RESTART CAPACITOR C_{RES}

The capacitor at the RES pin (C_{RES}) determines t_{RES} , which is the time the LM5117 remains off before a restart attempt is made in hiccup mode current limiting. t_{RES} for a given C_{RES} can be calculated from equation (13) as follows:

$$t_{RES} = \frac{0.47 \mu\text{F} \times 1.25V}{10 \mu\text{A}} = 59 \text{ ms}$$

For this example, a value of 0.47 μ F was chosen for a restart time of 59ms.

OUTPUT VOLTAGE DIVIDER R_{FB2} and R_{FB1}

R_{FB1} and R_{FB2} set the output voltage level. The ratio of these resistors is calculated as:

$$\frac{R_{FB2}}{R_{FB1}} = \frac{V_{OUT}}{0.8V} - 1$$

The ratio between R_{COMP} and R_{FB2} determines the mid-band gain, A_{FB_MID} . A larger value for R_{FB2} may require a corresponding larger value for R_{COMP} . R_{FB2} should be large enough to keep the total divider power dissipation small. 4.99k Ω was chosen for R_{FB2} in this example, which results in a R_{FB1} value of 357 Ω for 12V output.

LOOP COMPENSATION COMPONENTS C_{COMP} , R_{COMP} and C_{HF}

R_{COMP} , C_{COMP} and C_{HF} configure the error amplifier gain and phase characteristics to produce a stable voltage loop. For a quick start, follow the 4 steps listed below. For detailed information, see *Application Information*.

STEP1: Select f_{CROSS}

By selecting one tenth of the switching frequency, f_{CROSS} is calculated as follows:

$$f_{CROSS} = \frac{f_{SW}}{10} = 23 \text{ kHz}$$

STEP2: Determine required R_{COMP}

Knowing f_{CROSS} , R_{COMP} is calculated as follows:

$$R_{COMP} = 2\pi \times R_S \times A_S \times C_{OUT} \times R_{FB2} \times f_{CROSS} \quad [\Omega]$$

$$R_{COMP} = 2\pi \times 7.41 \text{ m}\Omega \times 10 \times 514 \text{ }\mu\text{F} \times 4.99 \text{ k}\Omega \times 23 \text{ kHz} = 27.5 \text{ k}\Omega$$

The standard value of 27.4k Ω was selected for R_{COMP}

STEP3: Determine C_{COMP} to cancel load pole

Knowing R_{COMP} , C_{COMP} is calculated as follows:

$$C_{COMP} = \frac{R_{LOAD} \times C_{OUT}}{R_{COMP}} \quad [F]$$

$$C_{COMP} = \frac{\frac{12V}{9A} \times 514 \text{ }\mu\text{F}}{27.4 \text{ k}\Omega} = 25 \text{ nF}$$

The standard value of 22nF was selected for C_{COMP}

STEP4: Determine C_{HF} to cancel ESR zero

Knowing R_{COMP} and C_{COMP} , C_{HF} is calculated as follows:

$$C_{HF} = \frac{R_{ESR} \times C_{OUT} \times C_{COMP}}{R_{COMP} \times C_{COMP} - R_{ESR} \times C_{OUT}} \quad [F]$$

$$C_{HF} = \frac{10 \text{ m}\Omega \times 514 \text{ }\mu\text{F} \times 22 \text{ nF}}{27.4 \text{ k}\Omega \times 22 \text{ nF} - 10 \text{ m}\Omega \times 514 \text{ }\mu\text{F}} = 189 \text{ pF}$$

Half of the maximum ESR is assumed as a typical ESR. The standard value of 180pF was selected for C_{HF} .

Application Circuit

LM5117

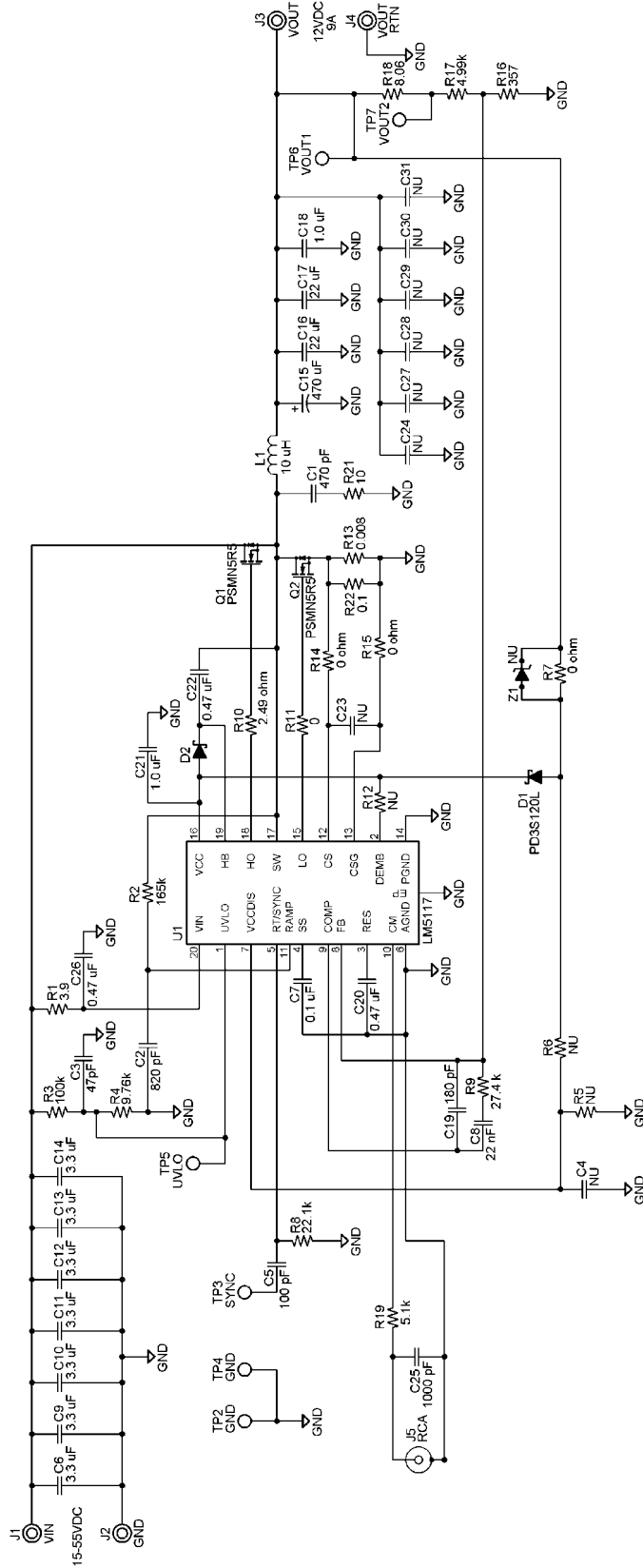

30143221

FIGURE 19. 12V, 9A Typical Application Schematic

Example of Constant Current Regulator

The LM5117 can be configured as a constant current regulator by using the current monitor feature (CM) as the feedback input. A voltage divider at the VCCDIS pin from VOUT to AGND can be used to protect against output over-voltage.

When the VCCDIS pin voltage is greater than the VCCDIS threshold, the controller disables the VCC regulator and the VCC pin voltage decays. When the VCC pin voltage is less than the VCC UV threshold, both HO and LO outputs stop switching. Due to the time delay required for VCC to decay below the VCC UV threshold, the over-voltage protection operates in hiccup mode. See [Figure 20](#).

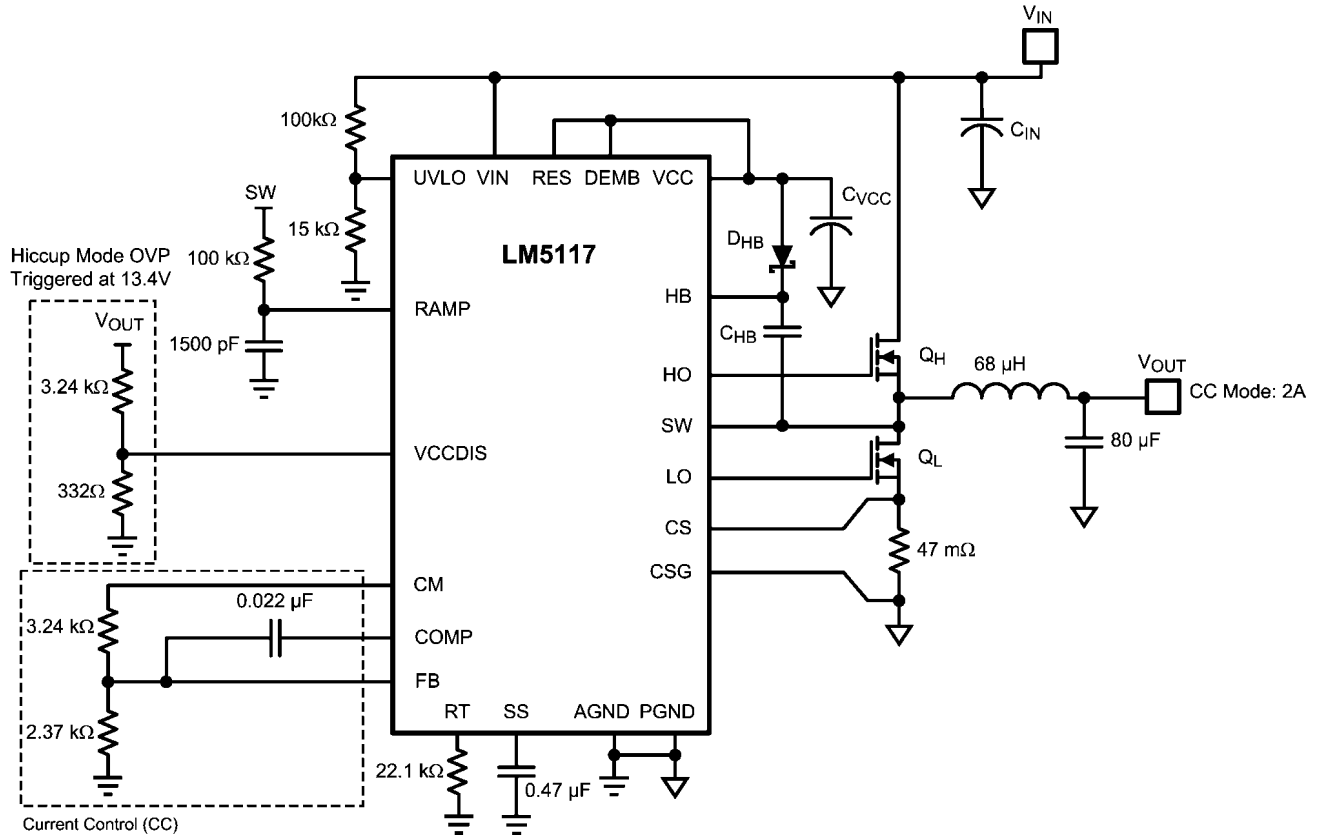

30143282

FIGURE 20. Constant Current Regulator with Hiccup Mode Output OVP

The LM5117 also can be configured as a constant voltage and constant current regulator, known as CV+CC regulator. In this configuration, there is much less variation in the current limiting as compared to peak cycle-by-cycle current limiting of the inductor current. The LMV431 and the PNP transistor create a voltage-to-current amplifier in the current loop. This amplifier circuitry does not affect the normal operation when

the output current is less than the current limit set-point. When the output current is greater than the set-point, the PNP transistor sources a current into C_{RAMP} and increases the positive slope of emulated inductor current ramp until the output current is less than or equal to the current limit set-point. See *Figure 21* and *Figure 22*.

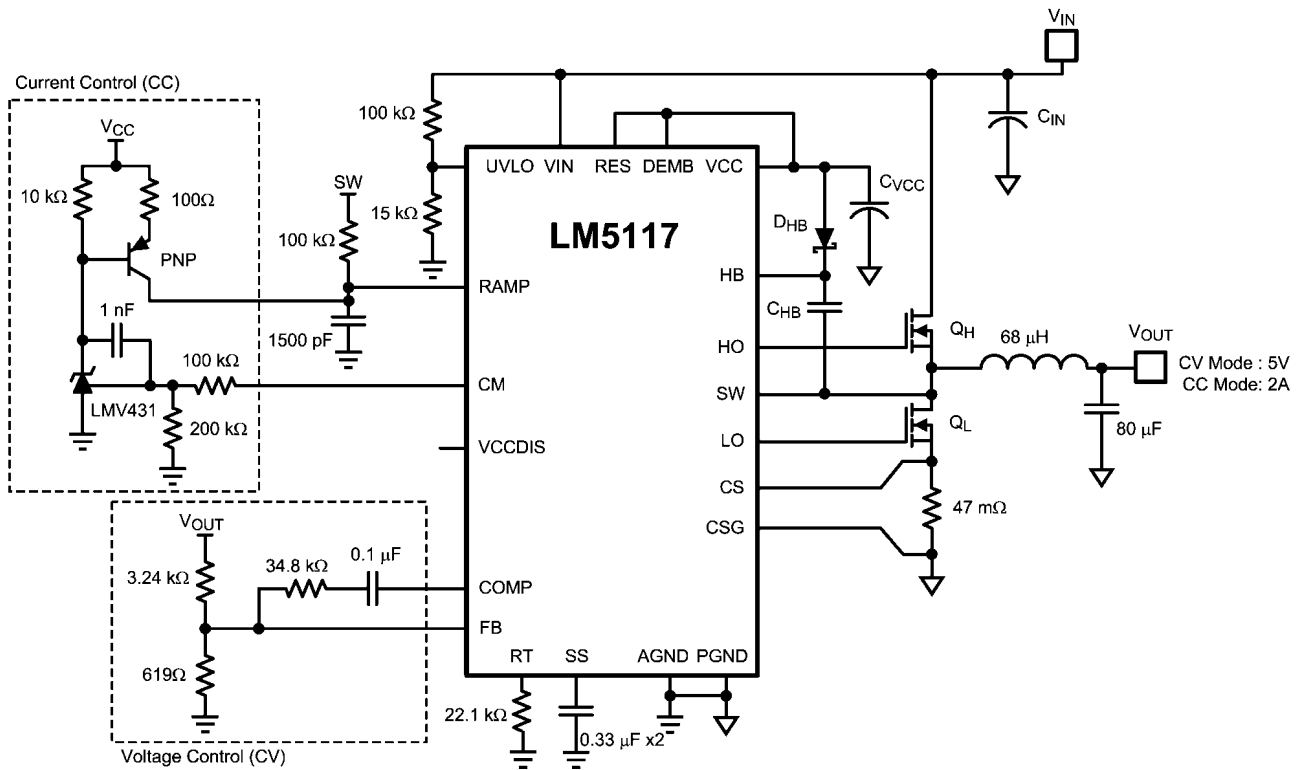

30143283

FIGURE 21. Constant Voltage Regulator with Accurate Current Limit

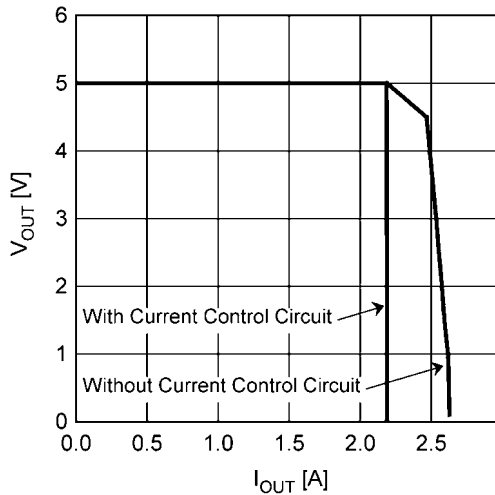

301432145

FIGURE 22. Current Limit Comparison

Physical Dimensions inches (millimeters) unless otherwise noted

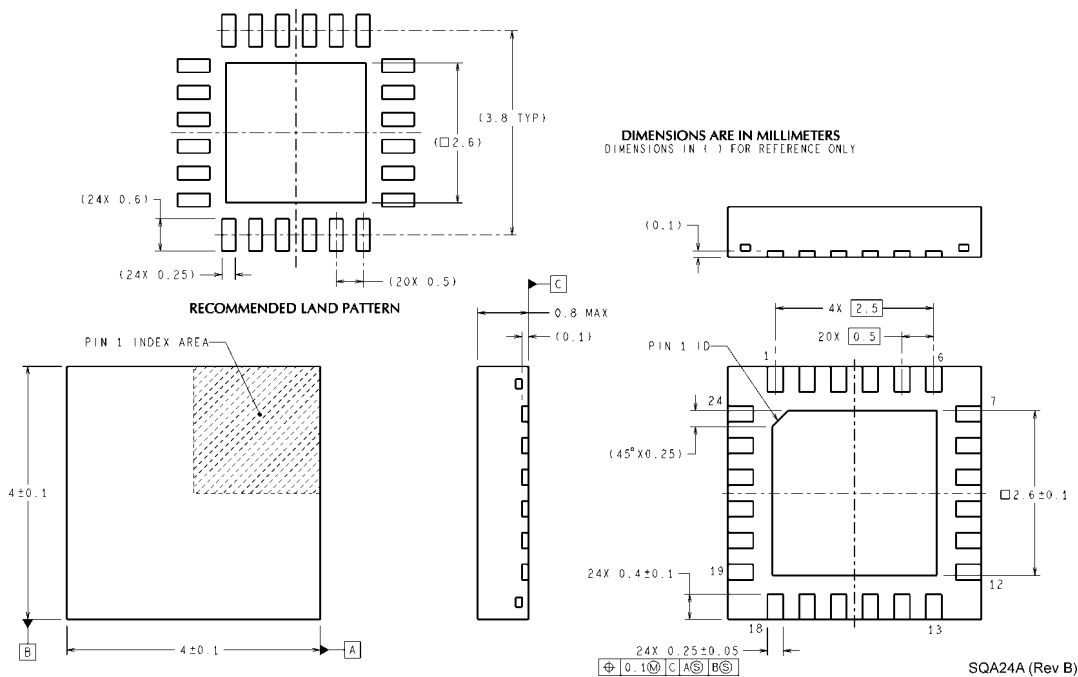
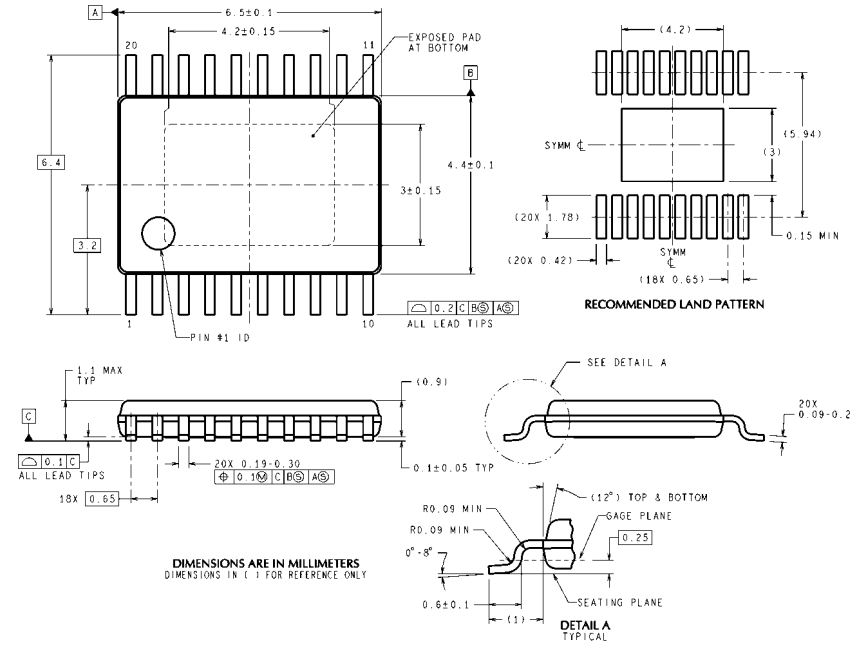

Notes

LMS117

Notes

For more National Semiconductor product information and proven design tools, visit the following Web sites at:
www.national.com

Products		Design Support	
Amplifiers	www.national.com/amplifiers	WEBENCH® Tools	www.national.com/webench
Audio	www.national.com/audio	App Notes	www.national.com/appnotes
Clock and Timing	www.national.com/timing	Reference Designs	www.national.com/refdesigns
Data Converters	www.national.com/adc	Samples	www.national.com/samples
Interface	www.national.com/interface	Eval Boards	www.national.com/evalboards
LVDS	www.national.com/lvds	Packaging	www.national.com/packaging
Power Management	www.national.com/power	Green Compliance	www.national.com/quality/green
Switching Regulators	www.national.com/switchers	Distributors	www.national.com/contacts
LDOs	www.national.com/lido	Quality and Reliability	www.national.com/quality
LED Lighting	www.national.com/led	Feedback/Support	www.national.com/feedback
Voltage References	www.national.com/vref	Design Made Easy	www.national.com/easy
PowerWise® Solutions	www.national.com/powerwise	Applications & Markets	www.national.com/solutions
Serial Digital Interface (SDI)	www.national.com/sdi	Mil/Aero	www.national.com/milaero
Temperature Sensors	www.national.com/tempensors	SolarMagic™	www.national.com/solarmagic
PLL/VCO	www.national.com/wireless	PowerWise® Design University	www.national.com/training

THE CONTENTS OF THIS DOCUMENT ARE PROVIDED IN CONNECTION WITH NATIONAL SEMICONDUCTOR CORPORATION ("NATIONAL") PRODUCTS. NATIONAL MAKES NO REPRESENTATIONS OR WARRANTIES WITH RESPECT TO THE ACCURACY OR COMPLETENESS OF THE CONTENTS OF THIS PUBLICATION AND RESERVES THE RIGHT TO MAKE CHANGES TO SPECIFICATIONS AND PRODUCT DESCRIPTIONS AT ANY TIME WITHOUT NOTICE. NO LICENSE, WHETHER EXPRESS, IMPLIED, ARISING BY ESTOPPEL OR OTHERWISE, TO ANY INTELLECTUAL PROPERTY RIGHTS IS GRANTED BY THIS DOCUMENT.

TESTING AND OTHER QUALITY CONTROLS ARE USED TO THE EXTENT NATIONAL DEEMS NECESSARY TO SUPPORT NATIONAL'S PRODUCT WARRANTY. EXCEPT WHERE MANDATED BY GOVERNMENT REQUIREMENTS, TESTING OF ALL PARAMETERS OF EACH PRODUCT IS NOT NECESSARILY PERFORMED. NATIONAL ASSUMES NO LIABILITY FOR APPLICATIONS ASSISTANCE OR BUYER PRODUCT DESIGN. BUYERS ARE RESPONSIBLE FOR THEIR PRODUCTS AND APPLICATIONS USING NATIONAL COMPONENTS. PRIOR TO USING OR DISTRIBUTING ANY PRODUCTS THAT INCLUDE NATIONAL COMPONENTS, BUYERS SHOULD PROVIDE ADEQUATE DESIGN, TESTING AND OPERATING SAFEGUARDS.

EXCEPT AS PROVIDED IN NATIONAL'S TERMS AND CONDITIONS OF SALE FOR SUCH PRODUCTS, NATIONAL ASSUMES NO LIABILITY WHATSOEVER, AND NATIONAL DISCLAIMS ANY EXPRESS OR IMPLIED WARRANTY RELATING TO THE SALE AND/OR USE OF NATIONAL PRODUCTS INCLUDING LIABILITY OR WARRANTIES RELATING TO FITNESS FOR A PARTICULAR PURPOSE, MERCHANTABILITY, OR INFRINGEMENT OF ANY PATENT, COPYRIGHT OR OTHER INTELLECTUAL PROPERTY RIGHT.

LIFE SUPPORT POLICY

NATIONAL'S PRODUCTS ARE NOT AUTHORIZED FOR USE AS CRITICAL COMPONENTS IN LIFE SUPPORT DEVICES OR SYSTEMS WITHOUT THE EXPRESS PRIOR WRITTEN APPROVAL OF THE CHIEF EXECUTIVE OFFICER AND GENERAL COUNSEL OF NATIONAL SEMICONDUCTOR CORPORATION. As used herein:

Life support devices or systems are devices which (a) are intended for surgical implant into the body, or (b) support or sustain life and whose failure to perform when properly used in accordance with instructions for use provided in the labeling can be reasonably expected to result in a significant injury to the user. A critical component is any component in a life support device or system whose failure to perform can be reasonably expected to cause the failure of the life support device or system or to affect its safety or effectiveness.

National Semiconductor and the National Semiconductor logo are registered trademarks of National Semiconductor Corporation. All other brand or product names may be trademarks or registered trademarks of their respective holders.

Copyright© 2011 National Semiconductor Corporation

For the most current product information visit us at www.national.com



**National Semiconductor
Americas Technical
Support Center**
Email: support@nsc.com
Tel: 1-800-272-9959

**National Semiconductor Europe
Technical Support Center**
Email: europe.support@nsc.com

**National Semiconductor Asia
Pacific Technical Support Center**
Email: ap.support@nsc.com

**National Semiconductor Japan
Technical Support Center**
Email: jpn.feedback@nsc.com