

General Description

The AOZ8040 is an 8-line device integrating EMI filtering with ESD protection for each line. It is designed to suppress unwanted EMI/RFI signals and provide electrostatic discharge (ESD) protection in portable electronic equipment. This state-of-the-art device utilizes AOS leading edge Trench Vertical Structure [TVS]²™ technology for superior clamping performance and filter attenuation over the full operating display range. The AOZ8040 has been optimized for protection of color LCD displays and CCD camera lines in cellular phones and other portable consumer electronic devices.

The AOZ8040 consists of eight identical circuits comprised of TVS diodes for ESD protection, and a resistor–capacitor network for EMI/RFI filtering. A series resistor value of 100Ω and a capacitance value of 9pF are used to achieve -20dB minimum attenuation from 1.0GHz to 3.0GHz. The TVS diodes provide effective suppression of ESD voltages in excess of ±20kV (air discharge) and ±20kV (contact discharge). This exceeds IEC 61000-4-2, level 4 ESD immunity test.

The AOZ8040 comes in an RoHS compliant, 1.2mm x 3.5mm, 0.4mm pitch DFN package and is rated over a -40°C to +85°C ambient temperature range.

Features

- 8 lines for EMI filtering and ESD protection:
 - Exceeds IEC 61000-4-2, level 4 (ESD) immunity test
 - ±20kV (air discharge) and ±20kV (contact discharge)
- Trench Vertical Structure [TVS]²™ based technology used to achieve excellent ESD clamping & filter performance over the full operating display range
- Filter performance: -20db attenuation from 1.0GHz to 3.0GHz
- Low operating voltage: 5.0V
- Capacitance stability over wide range of voltages and temperatures
- DFN package: 1.2mm x 3.5mm, 0.4mm pitch
- Pb-Free device
- Green product

Applications

- EMI filtering and ESD protection for data lines
- LCD displays, camera interface, I/O interface
- Portable handheld devices, cell phones, PDA phones



Typical Application

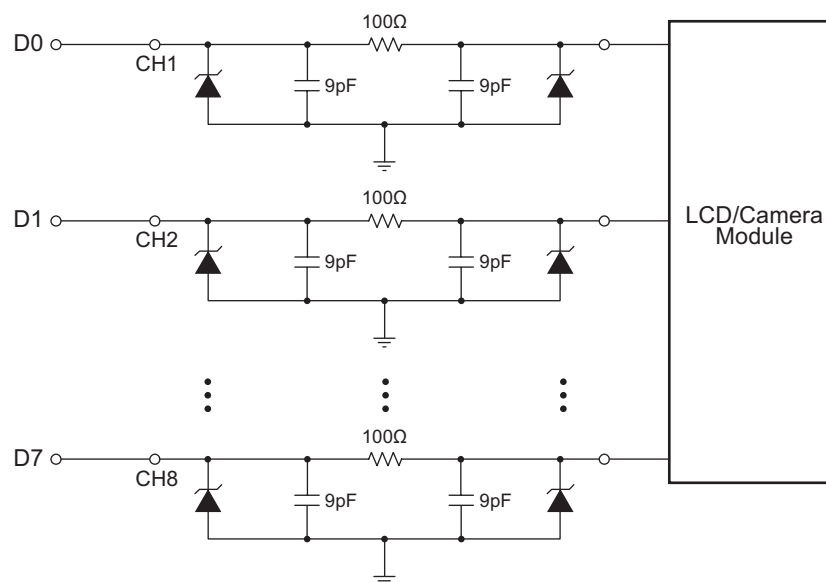

Figure 1.

Ordering Information

| Part Number | Ambient Temperature Range | Package | Environmental |
|-------------|---------------------------|---------|---------------------------------|
| AOZ8040DI | -40°C to +85°C | DFN-16 | RoHS Compliant Green Product |



AOS Green Products use reduced levels of Halogens, and are also RoHS compliant.

Please visit www.aosmd.com/web/quality/rohs_compliant.jsp for additional information.

Pin Configuration

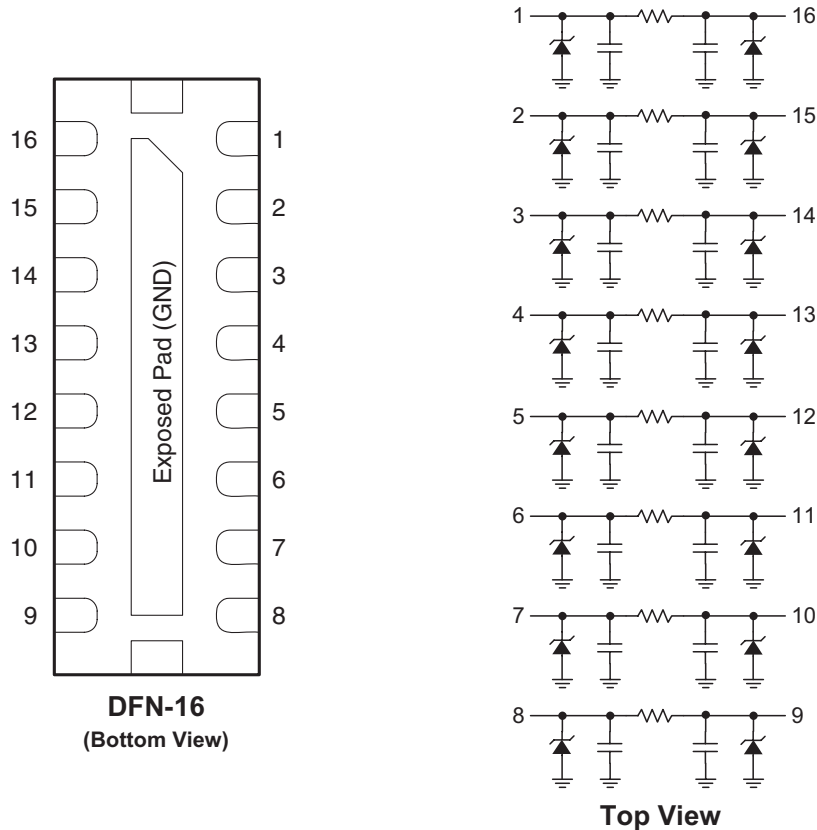

Pin Description

| Pin Number | Pin Name | Pin Function |
|-------------|----------|--------------------------|
| 1,16 | CH 1 | Channel 1 Connections |
| 2, 15 | CH 2 | Channel 2 Connections |
| 3, 14 | CH 3 | Channel 3 Connections |
| 4, 13 | CH 4 | Channel 4 Connections |
| 5, 12 | CH 5 | Channel 5 Connections |
| 6, 11 | CH 6 | Channel 6 Connections |
| 7, 10 | CH 7 | Channel 7 Connections |
| 8, 9 | CH 8 | Channel 8 Connections |
| Exposed Pad | GND | Common Ground Connection |

Absolute Maximum Ratings

Exceeding the Absolute Maximum ratings may damage the device.

| Parameter | Rating |
|---|-----------------|
| Storage Temperature (T _S) | -65°C to +150°C |
| ESD Rating per IEC61000-4-2, contact ⁽¹⁾ | ±20kV |
| ESD Rating per IEC61000-4-2, air ⁽¹⁾ | ±20kV |
| ESD Rating per Human Body Model ⁽²⁾ | ±30kV |

Notes:

- IEC 61000-4-2 discharge with C_{Discharge} = 150pF, R_{Discharge} = 330Ω.
- Human Body Discharge per MIL-STD-883, Method 3015 C_{Discharge} = 100pF, R_{Discharge} = 1.5kΩ.

Electrical Characteristics

T_A = 25°C unless otherwise specified.

| Symbol | Parameter | Conditions | Min. | Typ. | Max. | Units |
|------------------|-----------------------------------|---|------|------|-------|-------|
| V _{RWM} | Reverse Working Voltage | (3) | | | 5.0 | V |
| V _{BR} | Reverse Breakdown Voltage | I _T = 1mA ⁽⁴⁾ | 6 | 7 | 8 | V |
| I _R | Reverse Leakage Current | V _{RWM} = 3.3V | | | 0.1 | μA |
| V _{CL} | Signal Clamp Voltage | I _{LOAD} = 1A, positive clamp ⁽⁵⁾⁽⁸⁾ | | | 7.0 | V |
| | | I _{LOAD} = 1A, negative clamp ⁽⁵⁾⁽⁸⁾ | | | -3.0 | |
| | | I _{LOAD} = 5A, positive clamp ⁽⁵⁾⁽⁸⁾ | | | 8.0 | |
| | | I _{LOAD} = 5A, negative clamp ⁽⁵⁾⁽⁸⁾ | | | -5.0 | |
| | | I _{LOAD} = 12A, positive clamp ⁽⁵⁾⁽⁸⁾ | | | 10.0 | |
| | | I _{LOAD} = 12A, negative clamp ⁽⁵⁾⁽⁸⁾ | | | -10.0 | |
| R _{CH} | Total Series Resistance | I _R = 20mA | 90 | 100 | 110 | Ω |
| C _{CH} | Channel Capacitance | Input to Ground ⁽⁶⁾⁽⁷⁾⁽⁸⁾ | 8 | 9 | 10 | pF |
| f _C | Cut-off Frequency | Measured with 50Ω source and 50Ω load termination | | 250 | | MHz |
| | Attenuation from 1.0GHz to 3.0GHz | V _R = 0V Measured with 50Ω source and 50Ω load termination | | -20 | | dB |

Notes:

- The working peak reverse voltage, V_{RWM}, should be equal to or greater than the DC or continuous peak operating voltage level.
- V_{BR} is measured at the pulse test current I_T.
- Measurements performed using a 100ns Transmission Line Pulse (TLP) system.
- Total capacitance is equal to 2 x C_{CH}.
- Measured at 25°C, V_R = 2.5V, f = 1.0MHz.
- Guaranteed by design.

Typical Performance Characteristics

Insertion Loss Characteristics

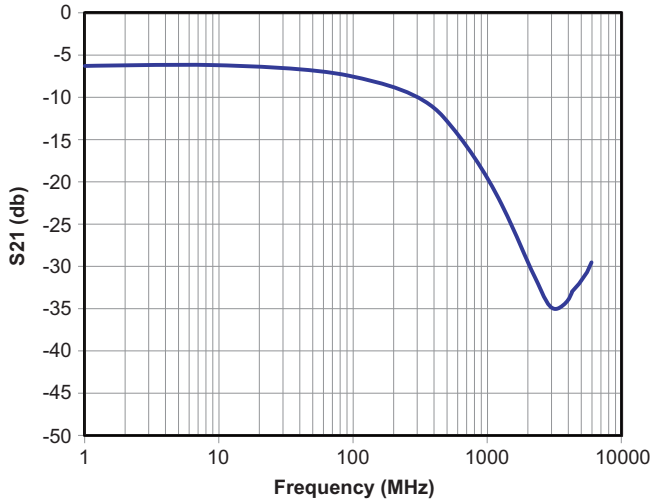

Crosstalk (I/O-I/O) vs. Frequency

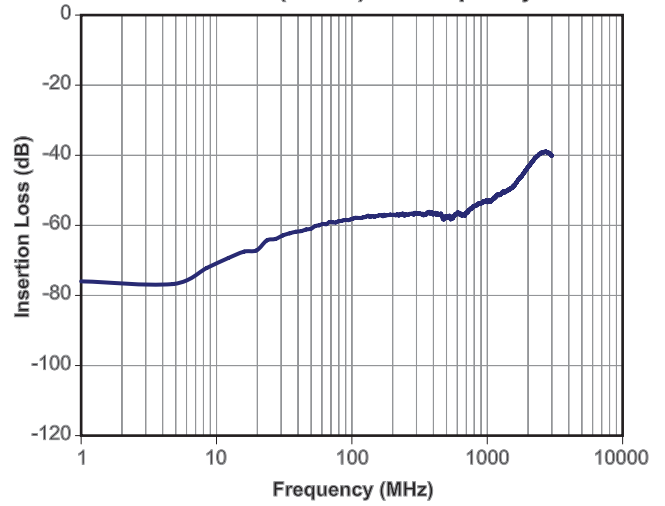

Clamping Voltage vs. Peak Pulse Current

($t_{\text{period}} = 100\text{ns}$, $t_r = 1\text{ns}$)

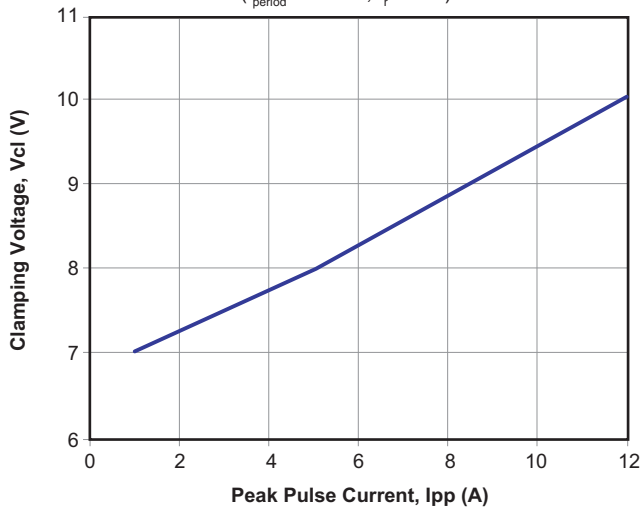

Forward Voltage vs. Forward Current

($t_{\text{period}} = 100\text{ns}$, $t_r = 1\text{ns}$)

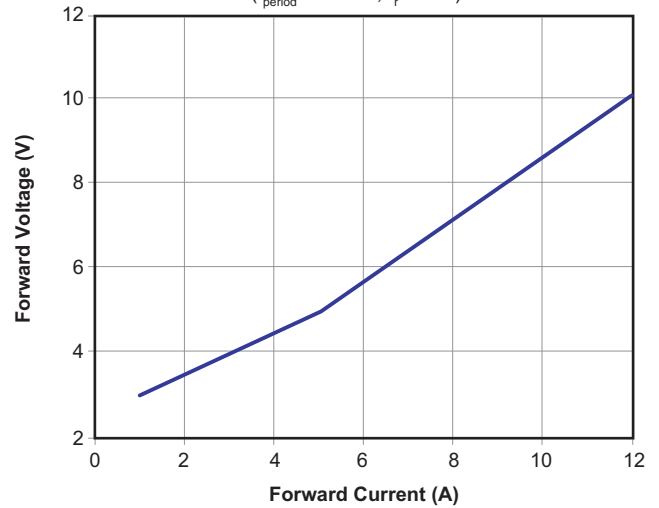

Typical Resistance vs. Temperature

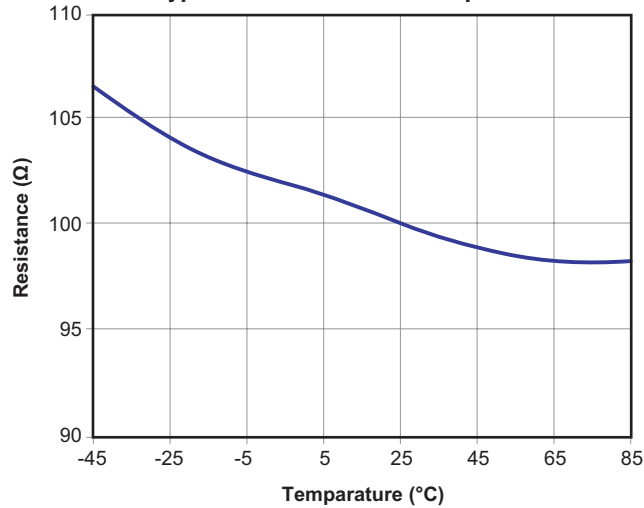

Package Dimensions, DFN 3.5 x 1.2, 16L

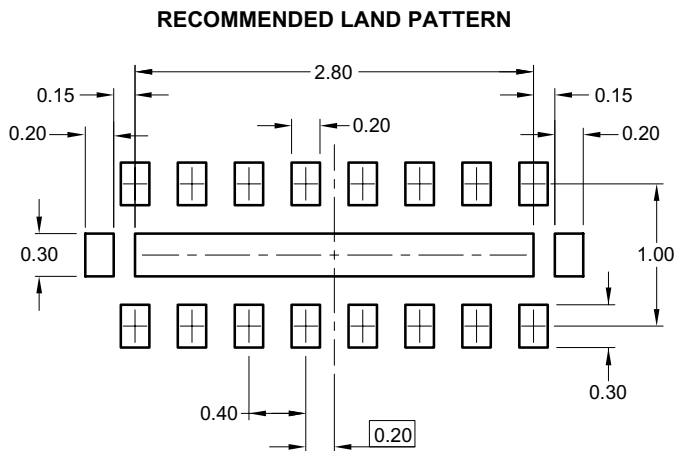
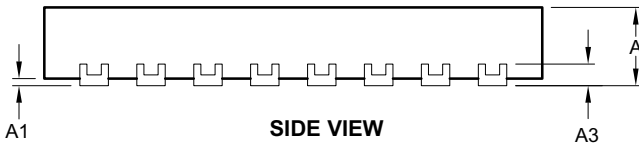
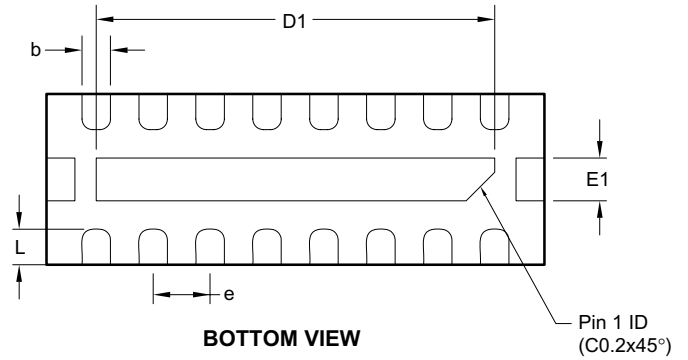
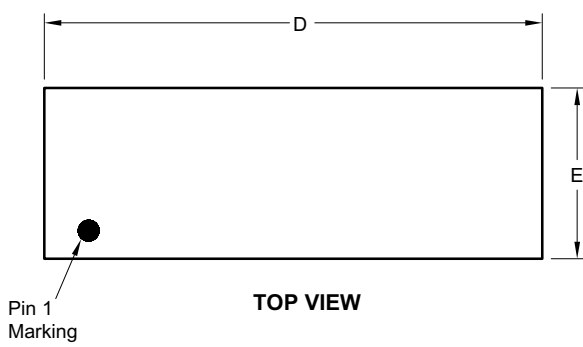

Dimensions in millimeters

| Symbols | Min. | Nom. | Max. |
|---------|------------|------|------|
| A | 0.50 | 0.55 | 0.60 |
| A1 | 0.00 | — | 0.05 |
| A3 | 0.152 Ref. | | |
| b | 0.15 | 0.20 | 0.25 |
| D | 3.45 | 3.50 | 3.55 |
| D1 | 2.75 | 2.80 | 2.85 |
| E | 1.15 | 1.20 | 1.25 |
| E1 | 0.25 | 0.30 | 0.35 |
| e | 0.40 BSC | | |
| L | 0.20 | 0.25 | 0.30 |

Dimensions in inches

| Symbols | Min. | Nom. | Max. |
|---------|------------|-------|-------|
| A | 0.020 | 0.022 | 0.024 |
| A1 | 0.000 | — | 0.002 |
| A3 | 0.006 Ref. | | |
| b | 0.006 | 0.008 | 0.010 |
| D | 0.136 | 0.138 | 0.140 |
| D1 | 0.108 | 0.110 | 0.112 |
| E | 0.045 | 0.047 | 0.049 |
| E1 | 0.010 | 0.012 | 0.014 |
| e | 0.016 BSC | | |
| L | 0.008 | 0.010 | 0.012 |

Notes:

1. All dimensions are in millimeters. Angles is degree.
2. Warpage shall not exceed 0.10mm.
3. Marking is for package orientation reference only.

Tape & Reel Dimensions, DFN 3.5 x 1.2, 16L

Carrier Tape

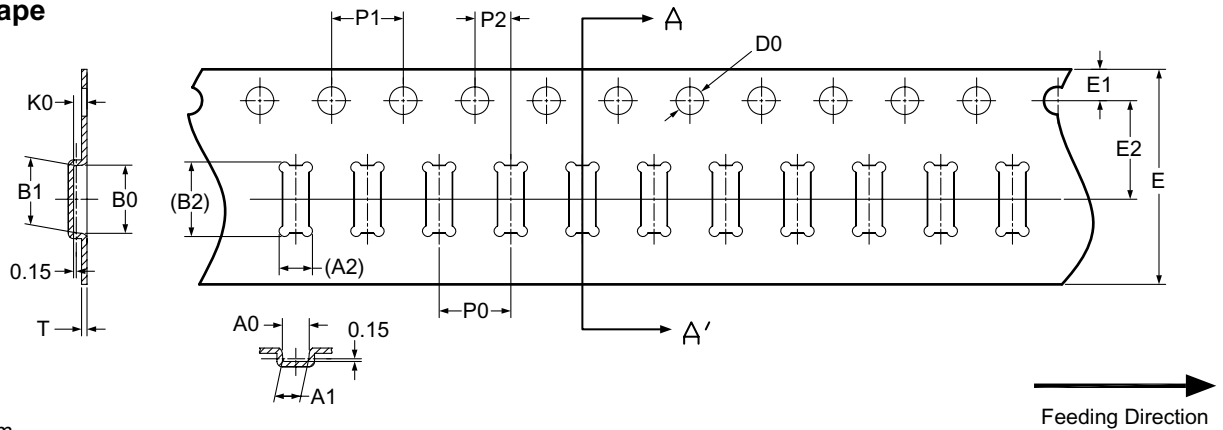

UNIT: mm

| Package | T | B0 | B1 | B2 | A0 | A1 | A2 | K0 | D0 | E | E1 | E2 | P0 | P1 | P2 |
|----------------|---------------|--------------|--------------|------|--------------|--------------|------|--------------|----------------|---------------|--------------|---------------|---------------|-------------|---------------|
| DFN 3.5x1.2 | 0.30 ±0.05 | 3.80 ±0.1 | 3.75 ±0.1 | 4.16 | 1.50 ±0.1 | 1.45 ±0.1 | 1.86 | 0.75 ±0.1 | ∅1.55 ±0.05 | 12.00 ±0.3 | 1.75 ±0.1 | 5.50 ±0.05 | 4.00 ±0.10 | 4.0 ±0.1 | 2.00 ±0.05 |

Reel

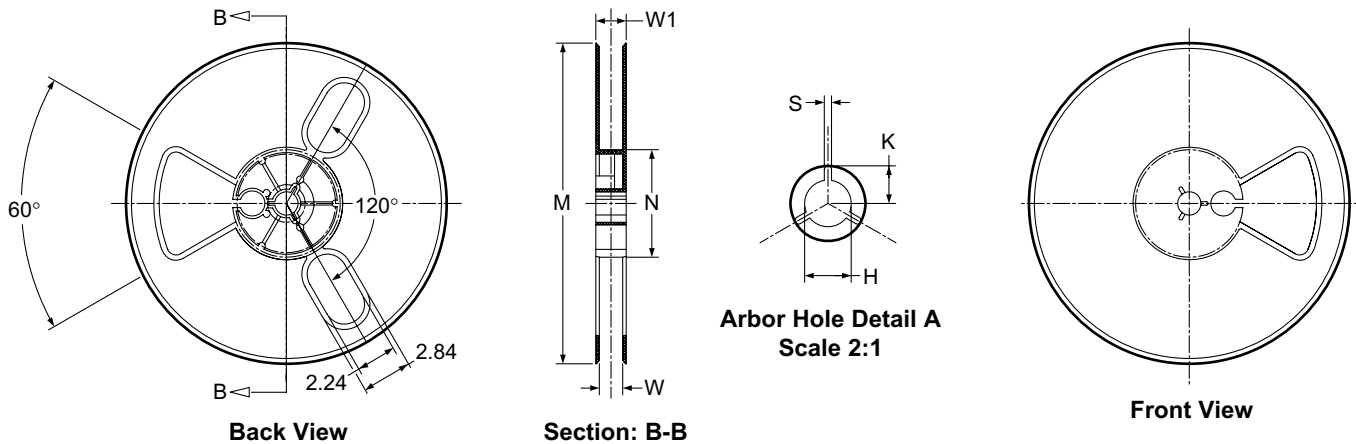

Unit: mm

| Tape Size | Reel Size | M | N | W | W1 | H | K | S |
|-----------|-----------|----------------|---------------|--------------|------|---------------|---------------|-----------------|
| 12mm | ∅1800 | ∅179.0 +1.0 | ∅60.0 ±0.5 | 13.0 ±0.5 | 17.0 | ∅13.0 ±0.2 | 10.5 ±0.25 | 1.8 (Bottom) |

Leader/Trailer & Orientation

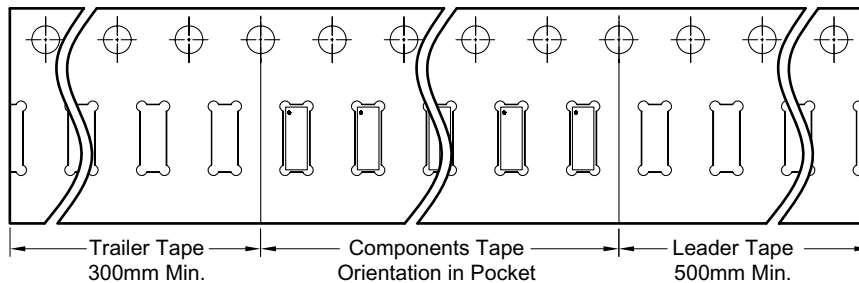

Package Marking

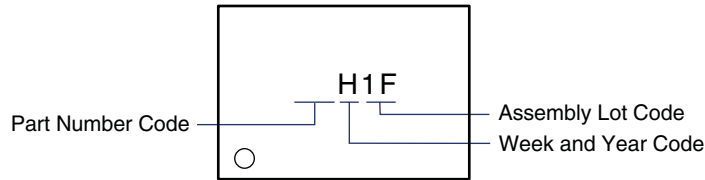

Alpha & Omega Semiconductor reserves the right to make changes to this data sheet at any time without notice.

LIFE SUPPORT POLICY

ALPHA & OMEGA SEMICONDUCTOR PRODUCTS ARE NOT AUTHORIZED FOR USE AS CRITICAL COMPONENTS IN LIFE SUPPORT DEVICES OR SYSTEMS.

As used herein:

1. Life support devices or systems are devices or systems which, (a) are intended for surgical implant into the body or (b) support or sustain life, and (c) whose failure to perform when properly used in accordance with instructions for use provided in the labeling, can be reasonably expected to result in a significant injury of the user.
2. A critical component in any component of a life support, device, or system whose failure to perform can be reasonably expected to cause the failure of the life support device or system, or to affect its safety or effectiveness.