

# R7 Series Servos

Advanced functionality in an ultra compact design



» Solve equipment problems

» Maximize performance

» Improve accuracy and increase productivity

# Ideal for a Wide Range of Applications: Ball Screws, Conveyor belts, X-Y Tables and more...

## Compact!

A super-compact, high-performance servo system that's easy to use.



### Smaller servo drives for multi-axis applications

The super-compact R7-Series is now even smaller. The footprint has been reduced by 52% from previous models minimizing control panel size.

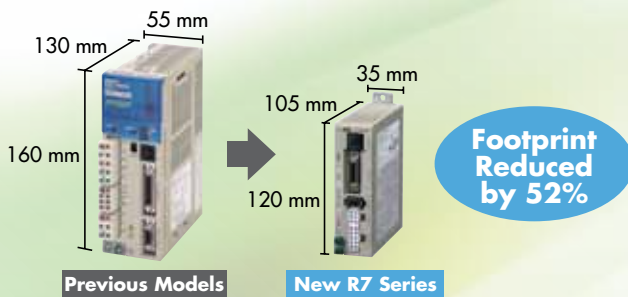

## Easy!

### Real time autotuning sets the optimum gain.

An auto-tuning function calculates the device load in real time and automatically sets the optimum gain to simplify the adjustment procedure.

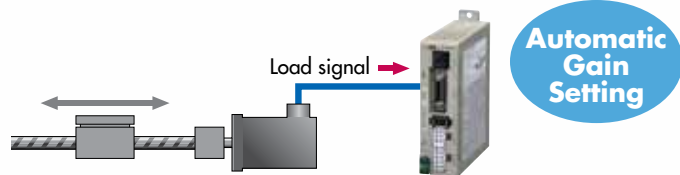

### Installation

The Servo Drive can be mounted onto a DIN Rail by using the DIN Rail Mounting Unit (sold separately) for easier assembly and easier maintenance.

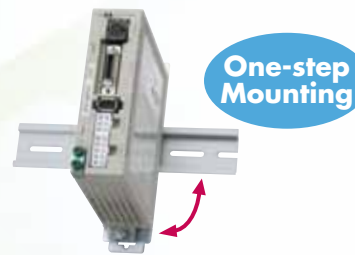

### Integrated development environment reduces your total cost of ownership.

The Servo system can be managed from design to maintenance with the CX-One Automation Suite.



#### Setting & Programming

Easy programming with the Smart FB Library



#### Parameter Editing & Monitoring

The Servomotor parameters can be edited, monitored, and saved with the CX-Drive.

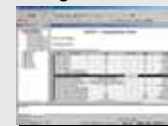

#### Alarm & Maintenance

Easy monitoring of the Drive errors

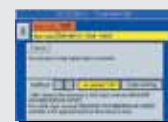

# Advanced functionality!

## Adaptive vibration suppression

The resonant frequency is automatically monitored to remove vibration using the adaptive filter. Even if the resonant frequency changes due to low mechanical rigidity, real time evaluation automatically follows the changes to reduce the effect of vibration.

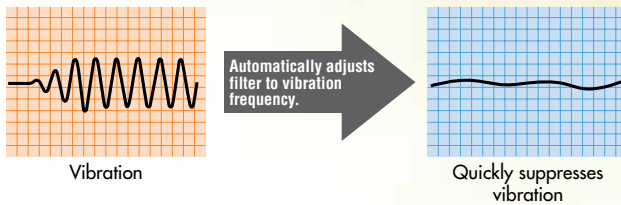

Reducing the amount of vibration improves positioning time and accuracy.

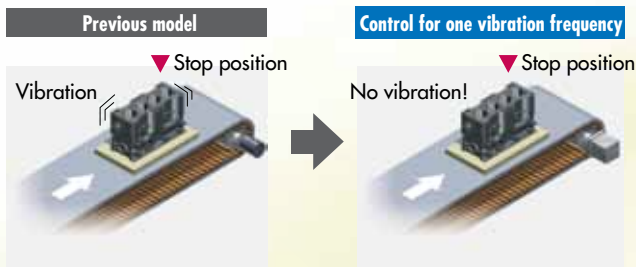

## Reduced process cycle time

The R7- Series accepts command pulse frequencies up to 500 kpps enabling high-speed positioning and high-precision control.

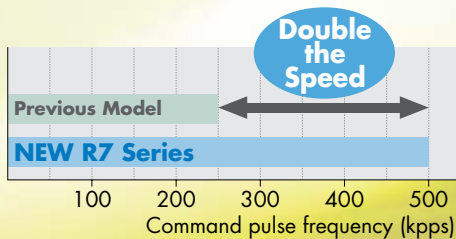

## Closed loop system

The present position can be checked using the feedback pulse sent from the Servo Drive to the Controller, allowing positioning errors due to mechanical problems to be monitored and eliminated in the Controller.

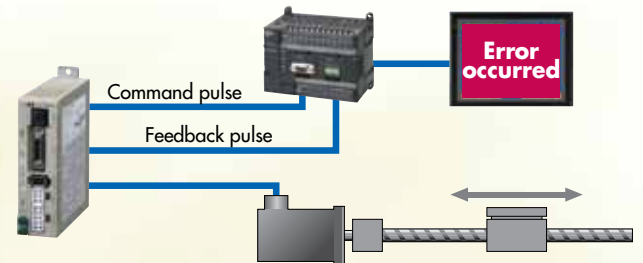

Simplified Synchronization: It is also possible to input encoder output signals directly into the servo drive.

## Torque limiting function

Set two torque limits, and switch between them. Great for application, such as pressing or part insertion.

Torque limiting reduces machine or work piece breakdown occurrence.

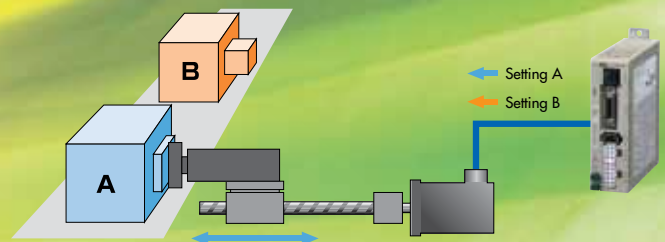

## Servo Drive Model Numbers

The model number provides information such as the Servo Drive type, the applicable Servomotor capacity, and the power supply voltage.

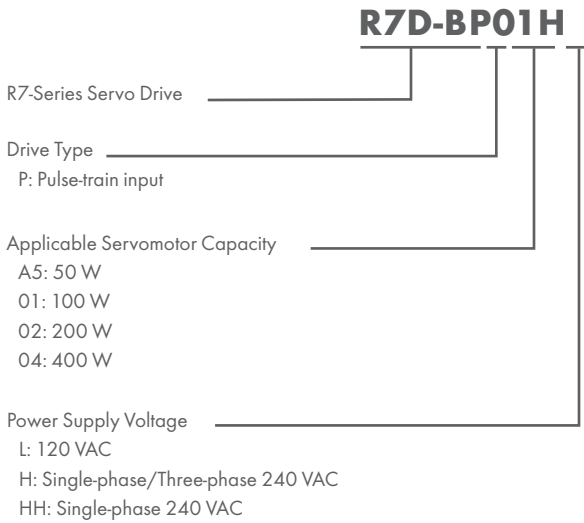

## Servomotor Model Numbers

The model number provides information such as the Servomotor type, Servomotor capacity, rated speed and options.

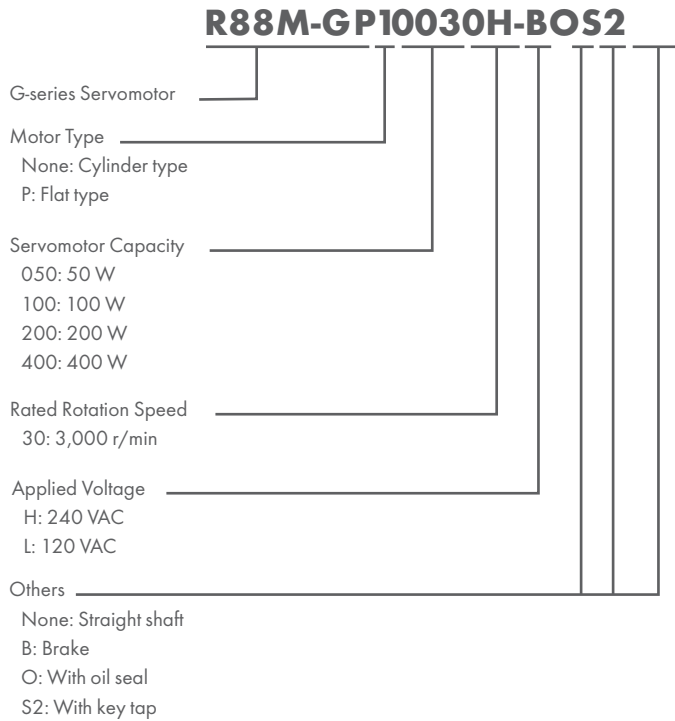

## Servo Drive-Servomotor Combinations

Only the Servomotor and Servo Drive combinations listed here can be used. Do not use other combinations.

### Cylindrical Servomotor

#### Servomotors Combinations

Voltage	Servo Drive	Rated output	Servomotor	
	Pulse-train input		Without brake	With brake
Single-phase 120VAC	R7D-BPA5L	50 W	R88M-G05030H-S2	R88M-G05030H-B52
	R7D-BP01L	100 W	R88M-G10030L-S2	R88M-G10030L-B52
	R7D-BP02L	200 W	R88M-G20030L-S2	R88M-G20030L-B52
Single-phase 240 VAC	R7D-BP01H	50 W	R88M-G05030H-S2	R88M-G05030H-B52
		100 W	R88M-G10030H-S2	R88M-G10030H-B52
	R7D-BP02HH	200 W	R88M-G20030H-S2	R88M-G20030H-B52
	R7D-BP04H	400 W	R88M-G40030H-S2	R88M-G40030H-B52
Three-phase 240 VAC	R7D-BP01H	50 W	R88M-G05030H-S2	R88M-G05030H-B52
		100 W	R88M-G10030H-S2	R88M-G10030H-B52
	R7D-BP02H	200 W	R88M-G20030H-S2	R88M-G20030H-B52
	R7D-BP04H	400 W	R88M-G40030H-S2	R88M-G40030H-B52

### Flat Servomotor

#### Servomotors Combinations

Voltage	Servo Drive	Rated output	Servomotor	
	Pulse-train input		Without brake	With brake
Single-phase 120VAC	R7D-BP01L	100 W	R88M-GP10030L-S2	R88M-GP10030L-B52
	R7D-BP02L	200 W	R88M-GP20030L-S2	R88M-GP20030L-B52
Single-phase 240 VAC	R7D-BP01H	100 W	R88M-GP10030H-S2	R88M-GP10030H-B52
	R7D-BP02HH	200 W	R88M-GP20030H-S2	R88M-GP20030H-B52
	R7D-BP04H	400 W	R88M-GP40030H-S2	R88M-GP40030H-B52
Three-phase 240 VAC	R7D-BP01H	100 W	R88M-GP10030H-S2	R88M-GP10030H-B52
	R7D-BP02H	200 W	R88M-GP20030H-S2	R88M-GP20030H-B52
	R7D-BP04H	400 W	R88M-GP40030H-S2	R88M-GP40030H-B52



## Accessories and Cables

### CN1 Control Cables for CP1H/CP1L or general purpose controllers

Specifications	Model	
Connector-Terminal Block Cables	1 m	XW2Z-100J-B28
	2 m	XW2Z-200J-B28
General-purpose Control Cables	1 m	R7A-CPB001S
	2 m	R7A-CPB002S

### Encoder Cables (for CN2) \*1

Specifications	Model	
Standard Cables (connectors attached)	3 m	R88A-CRGB003C
	5 m	R88A-CRGB005C
	10 m	R88A-CRGB010C
	15 m	R88A-CRGB015C
	20 m	R88A-CRGB020C

### Servomotor Power Cables (for CNB) \*1

Specifications	Model	
Standard Cables (connectors attached)	3 m	R7A-CAB003S
	5 m	R7A-CAB005S
	10 m	R7A-CAB010S
	15 m	R7A-CAB015S
	20 m	R7A-CAB020S

### Brake Cables

Specifications	Model	
Standard Cables	3 m	R88A-CAGA003B
	5 m	R88A-CAGA005B
	10 m	R88A-CAGA010B
	15 m	R88A-CAGA015B
	20 m	R88A-CAGA020B

### Connectors

Specifications	Model
Main Circuit Connector (CNA)	R7A-CNB01P
Servomotor Connector (CNB)	R7A-CNB01A
Control Input Connector (CN1)	R88A-CNW01C
Encoder Input Connector (CN2)	R88A-CNW01R
Servomotor Connector for Encoder Cable	R88A-CNG02R
Servomotor Connector for Servomotor Power Cable	R88A-CNG01A

### Power Supply Cables (For CNA)

Specifications	Model	
Power Supply Input Cable for Single-Phase Power (connectors attached)	2 m	R7A-CLB002S2
Power Supply Input Cable for Three-Phase Power (connectors attached)	2 m	R7A-CLB002S3
External Regenerative Resistor Connection Cable	2 m	R7A-CLB002RG

### Personal Computer Monitor Cable

Specifications	Model	
Personal Computer Monitor Cable	2 m	R88A-CCG002P2

\*1: For high flex cables add an "R" at the end of the part number.

### Terminal Blocks for CP1H/CP1L or general purpose controllers

Specifications	Model
With M3 screws	XW2B-34G4
With M3.5 screws	XW2B-34G5
With M3 screws	XW2D-34G6

### External Regeneration Resistors

Specifications	Model
220 W, 47 Ω	R88A-RR22047S
80 W, 100 Ω	R88A-RR080100S
80 W, 50 Ω	R88A-RR08050S

### Reactors

Specifications	Applicable Servo Drive	Model
Single-phase 120 V	R7D-BPA5L	3G3AX-DL2002
	R7D-BP01L	3G3AX-DL2004
	R7D-BP02L	3G3AX-DL2007
Single-phase 240 V	R7D-BP01H	3G3AX-DL2004
	R7D-BP02HH	3G3AX-DL2004
	R7D-BP04H	3G3AX-DL2007
	Three-phase 240 V	R7D-BP01H
R7D-BP02H		3G3AX-AL2025
R7D-BP04H		3G3AX-AL2025

### DIN Rail Mounting Unit

Specifications	Model
DIN Rail Mounting Unit	R7A-DIN01B

### Parameter Unit

Specifications	Model
Parameter Unit	R88A-PR02G

### Servo Drive Nomenclature

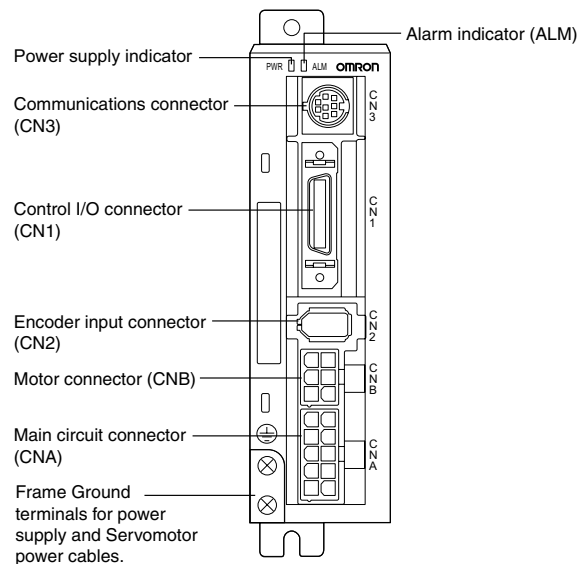

Select the Servo Terminal block and Cable according to the model number of the Position Control Unit being used.

Position Control Unit	Position Control Unit Cable	Servo Terminal block (Relay Unit)	Servo Drive Cable <sup>1</sup>
CJ1W-NC133	XW2Z-050J-A18 XW2Z-100J-A18	XW2B-20J6-1B	XW2Z-100J-B29 XW2Z-200J-B29
CJ1W-NC233	XW2Z-050J-A19 XW2Z-100J-A19	XW2B-40J6-2B	
CJ1W-NC433			
CS1W-NC133	XW2Z-050J-A10 XW2Z-100J-A10	XW2B-20J6-1B	
CS1W-NC233	XW2Z-050J-A11 XW2Z-100J-A11	XW2B-40J6-2B	
CS1W-NC433			
CJ1W-NC113	XW2Z-050J-A14 XW2Z-100J-A14	XW2B-20J6-1B	
CJ1W-NC213	XW2Z-050J-A15 XW2Z-100J-A15	XW2B-40J6-2B	
CJ1W-NC413			
CS1W-NC113	XW2Z-050J-A6 XW2Z-100J-A6	XW2B-20J6-1B	
C200HW-NC113			
CS1W-NC213	XW2Z-050J-A7 XW2Z-100J-A7	XW2B-40J6-2B	
CS1W-NC413			
C200HW-NC213			
C200HW-NC413			
CJ1M-CPU21	XW2Z-050J-A33 XW2Z-100J-A33	XW2B-20J6-8A XW2B-40J6-9A (for 2 axes)	XW2Z-100J-B32 XW2Z-200J-B32
CJ1M-CPU22			
CJ1M-CPU23			
CQM1H-PLB21	XW2Z-050J-A3 XW2Z-100J-A3	XW2B-20J6-3B	XW2Z-100J-B29 XW2Z-200J-B29

Note: 1. Two Servo Drive Cables are required if 2-axis control is performed.

Note: Cable Length

050 = 0.5 m  
100 = 1 m  
200 = 2 m

## Characteristics

### 120 VAC specification

Item	Servo Drive model		
	R7D-BPA5L	R7D-BP01L	R7D-BP02L
Continuous output current (rms)	1.0 A	1.6 A	2.5 A
Momentary maximum output current (rms)	3.3 A	5.1 A	7.5 A
Power supply capacity	0.16 KVA	0.25 KVA	0.42 KVA
Input power supply voltage (main circuit)	Single-phase 120 VAC (85 to 127 V), 50/60 Hz		
Input power supply current (rms) (main circuit)	1.4 A	2.2 A	3.7 A
Heat generated (main circuit)	12 W	16 W	22 W
Control method	All-digital servo		
Inverter method	IGBT-driven PWM method		
PWM frequency	12 kHz		6 kHz
Maximum response frequency (command pulses)	Line drive: 500 kpps, Open collector: 200 kpps		
Weight	0.35 kg		0.42 kg
Applicable motor capacity	50 W	100 W	200 W

### 240 VAC specification

Item	Servo Drive model			
	R7D-BP01H	R7D-BP02HH	R7D-BP02H	R7D-BP04H
Continuous output current (rms)	1.0 A	1.6 A	1.6 A	2.5 A
Momentary maximum output current (rms)	3.3 A	4.9 A	4.9 A	7.8 A
Power supply capacity	0.27 KVA (0.30 KVA) See note	(0.35 KVA) See note	0.42 KVA	0.69 KVA (0.77 KVA) See note
Input power supply voltage (main circuit)	Both single-phase and three-phase 200 to 240 VAC (170 to 264 V), 50/60 Hz			
Input power supply current (rms) (main circuit)	0.7 A (1.5 A) See note	(1.6 A) See note	1.1 A	1.8 A (3.5 A) See note
Heat generated (main circuit)	14 W	16 W	20 W	26W
Control method	All-digital servo			
Inverter method	IGBT-driven PWM method			
PWM frequency	12 kHz		6 kHz	
Maximum response frequency (command pulses)	Line drive: 500 kpps, Open collector: 200 kpps			
Weight	0.35 kg		0.42 kg	
Applicable motor capacity	100 W	200 W	200 W	400 W

Note: Values inside parentheses ( ) are for single-phase 240-V use.

## 3,000-r/min Cylindrical Servomotors

### 120 VAC specification

Item	Unit	R88M-G05030H-S2	R88M-G10030L-S2	R88M-G20030L-S2
Rated output <sup>*1</sup>	W	50	100	200
Rated torque <sup>*1</sup>	N·m	0.16	0.32	0.64
Rated rotation speed	r/min	3000		
Max. rotation speed	r/min	5000		
Max. momentary torque <sup>*1</sup>	N·m	0.48	0.95	1.78
Rated current <sup>*1</sup>	A (rms)	1.1	1.7	2.5
Max. momentary current <sup>*1</sup>	A (rms)	3.4	5.1	7.6
Rotor inertia	kg·m <sup>2</sup>	2.5 × 10 <sup>-6</sup>	5.1 × 10 <sup>-6</sup>	1.4 × 10 <sup>-5</sup>
Applicable load inertia	---	30 times rotor inertia max.		

\*1. These are the values when the Servomotor is combined with a Servo Drive at room temperature.  
The momentary maximum torque shown above indicates the standard value.

## 3,000-r/min Cylindrical Servomotors

### 240 VAC specification

Item	Unit	R88M-G05030H-S2	R88M-G10030H-S2	R88M-G20030H-S2	R88M-G40030H-S2
Rated output <sup>*1</sup>	W	50	100	200	400
Rated torque <sup>*1</sup>	N·m	0.16	0.32	0.64	1.3
Rated rotation speed	r/min	3000			
Max. rotation speed	r/min	5000			
Max. momentary torque <sup>*1</sup>	N·m	0.48	0.95	1.78	3.60
Rated current <sup>*1</sup>	A (rms)	1.1	1.1	1.6	2.6
Max. momentary current <sup>*1</sup>	A (rms)	3.4	3.4	4.9	7.9
Rotor inertia	kg·m <sup>2</sup>	2.5 × 10 <sup>-6</sup>	5.1 × 10 <sup>-6</sup>	1.4 × 10 <sup>-5</sup>	2.6 × 10 <sup>-5</sup>
Applicable load inertia	---	30 times rotor inertia max.			

\*1. These are the values when the Servomotor is combined with a Servo Drive at room temperature.  
The momentary maximum torque shown above indicates the standard value.

## 3,000-r/min Flat Servomotors

### 120 VAC specification

Item	Unit	R88M-GP10030L-S2	R88M-GP20030L-S2
Rated output <sup>*1</sup>	W	100	200
Rated torque <sup>*1</sup>	N·m	0.32	0.64
Rated rotation speed	r/min	3000	
Max. rotation speed	r/min	5000	
Max. momentary torque <sup>*1</sup>	N·m	0.85	1.86
Rated current <sup>*1</sup>	A (rms)	1.6	2.5
Max. momentary current <sup>*1</sup>	A (0-p)	6.9	10.5
Rotor inertia	kg·m <sup>2</sup>	9.0 × 10 <sup>-6</sup>	3.4 × 10 <sup>-5</sup>
Applicable load inertia	---	20 times rotor inertia max.	

\*1. These are the values when the Servomotor is combined with a Servo Drive at room temperature.  
The momentary maximum torque shown above indicates the standard value.

## 3,000-r/min Flat Servomotors

### 240 VAC specification

Item	Unit	R88M-GP10030H-S2	R88M-GP20030H-S2	R88M-GP40030H-S2
Rated output <sup>*1</sup>	W	100	200	400
Rated torque <sup>*1</sup>	N·m	0.32	0.64	1.3
Rated rotation speed	r/min	3000		
Max. rotation speed	r/min	5000		
Max. momentary torque <sup>*1</sup>	N·m	0.90	1.82	3.60
Rated current <sup>*1</sup>	A (rms)	1.0	1.6	4.4
Max. momentary current <sup>*1</sup>	A (0-p)	4.3	6.8	18.6
Rotor inertia	kg·m <sup>2</sup>	9.0 × 10 <sup>-6</sup>	3.4 × 10 <sup>-5</sup>	6.4 × 10 <sup>-5</sup>
Applicable load inertia	---	20 times rotor inertia max.		

\*1. These are the values when the Servomotor is combined with a Servo Drive at room temperature.  
The momentary maximum torque shown above indicates the standard value.

**OMRON ELECTRONICS LLC • THE AMERICAS HEADQUARTERS** • Schaumburg, IL USA • 847.843.7900 • 800.556.6766 • [www.omron247.com](http://www.omron247.com)

**OMRON CANADA, INC. • HEAD OFFICE**

Toronto, ON, Canada • 416.286.6465 • 866.986.6766  
[www.omron247.com](http://www.omron247.com)

**OMRON ELETRÔNICA DO BRASIL LTDA • HEAD OFFICE**

São Paulo, SP, Brasil • 55.11.2101.6300 • [www.omron.com.br](http://www.omron.com.br)

**OMRON ELECTRONICS MEXICO SA DE CV • HEAD OFFICE**

Apodaca, N.L. • 52.811.156.99.10 • 001.800.556.6766 • [mela@omron.com](mailto:mela@omron.com)

**OMRON ARGENTINA • SALES OFFICE**

Cono Sur • 54.11.4783.5300

**OMRON CHILE • SALES OFFICE**

Santiago • 56.9.9917.3920

**OTHER OMRON LATIN AMERICA SALES**

54.11.4783.5300

**OMRON EUROPE B.V.** Wegalaan 67-69, NL-2132 JD, Hoofddorp, The Netherlands. Tel: +31 (0) 23 568 13 00 Fax: +31 (0) 23 568 13 88 [www.industrial.omron.eu](http://www.industrial.omron.eu)

*Authorized Distributor:*

**Automation Systems**

- Programmable logic controllers (PLC) • Human machine interfaces (HMI) • Remote I/O
- Industrial PC's • Software

**Motion & Drives**

- Motion controllers • Servo systems • AC drives

**Control Components**

- Temperature controllers • Power supplies • Timers • Counters • Programmable relays
- Digital panel indicators • Electromechanical relays • Monitoring products • Solid-state relays
- Limit switches • Pushbutton switches • Low voltage switch gear

**Sensing & Safety**

- Photoelectric sensors • Inductive sensors • Capacitive & pressure sensors
- Cable connectors • Displacement & width-measuring sensors • Vision systems
- Safety networks • Safety sensors • Safety units/relay units • Safety door/guard lock switches