

TAPE AND REEL SPECIFICATIONS FOR ALL RIGHT ANGLE SURFACE MOUNT MICRO-FIT(3.0)

PACKAGING ITEM NO.	ASSEMBLY ITEM NO.	EMBOSSSED TAPE ITEM NO.	CKT. SIZE	PARTS PER REEL	REELS/ CARTON	SPQ PARTS PER CARTON	COVER TAPE ITEM NO.	CARRIER REEL/HALF ITEM NO.	CARRIER REEL/HALF ITEM NO.	DIM A	DIM B	DIM C
70873-0502	43045-02**	70180-2702	2	200	9	1800	43655-0001	70180-6501	70180-6501	1.260/(32.00)	1.118/(28.40)	1.276/(32.40)
70873-0504	43045-04**	70180-2704	4	200	9	1800	43655-0001	70180-6501	70180-6501	1.260/(32.00)	1.118/(28.40)	1.276/(32.40)
70873-0506	43045-06**	70180-2706	6	200	9	1800	43655-0001	70180-6501	70180-6501	1.260/(32.00)	1.118/(28.40)	1.276/(32.40)
70873-0508	43045-08**	70180-2708	8	200	7	1400	43655-0002	70180-6501	70180-6502	1.732/(44.00)	1.591/(40.40)	1.748/(44.40)
70873-0510	43045-10**	70180-2710	10	200	7	1400	43655-0002	70180-6501	70180-6502	1.732/(44.00)	1.591/(40.40)	1.748/(44.40)
70873-0512	43045-12**	70180-2712	12	200	7	1400	43655-0002	70180-6501	70180-6502	1.732/(44.00)	1.591/(40.40)	1.748/(44.40)
70873-0514	43045-14**	70180-2714	14	200	7	1400	43655-0002	70180-6501	70180-6502	1.732/(44.00)	1.591/(40.40)	1.748/(44.40)
70873-0516	43045-16**	70180-2716	16	200	5	1000	43655-0003	70180-6502	70180-6502	2.205/(56.00)	2.063/(52.40)	2.220/(56.40)
70873-0518	43045-18**	70180-2718	18	200	5	1000	43655-0003	70180-6502	70180-6502	2.205/(56.00)	2.063/(52.40)	2.220/(56.40)
70873-0520	43045-20**	70180-2720	20	200	5	1000	43655-0003	70180-6502	70180-6502	2.205/(56.00)	2.063/(52.40)	2.220/(56.40)
70873-0522	43045-22**	70180-2722	22	200	5	1000	43655-0003	70180-6502	70180-6502	2.205/(56.00)	2.063/(52.40)	2.220/(56.40)
70873-0524	43045-24**	70180-2724	24	200	5	1000	43655-0003	70180-6502	70180-6502	2.205/(56.00)	2.063/(52.40)	2.220/(56.40)

- NOTES:
- 1) PACKAGING MATERIALS: EMBOSSSED CARRIER TAPE IS POLYSTYRENE (PS), TOP COVER TAPE IS A COMPOSITE OF POLYETHYLENE TEREPHTHALATE (PET), POLYETHYLENE (PE), AND POLYFILM (PEF), CARRIER REEL IS POLYSTYRENE (PS).
  - 2) THIS CONNECTOR COMPLIES WITH MOLEX PRODUCT SPECIFICATION PS-43045.
  - 3) EACH REEL MUST BE LOADED WITH 200 CONNECTORS (SEE NOTE 5).
  - 4) THE FOLLOWING NOTES HAVE BEEN DERIVED FROM THE E.I.A. STANDARDS 481.
  - 5) CONNECTOR MINIMUMS/REEL ARE SHOWN ABOVE, IN NO CASE SHALL THERE BE TWO CONSECUTIVE COMPONENTS MISSING BETWEEN THE FIRST AND LAST PART OF ANY REEL.
  - 6) THE TOP COVER TAPE SHALL BE CLEAR ONLY, NOT EXTEND OVER THE EDGES OF THE CARRIER TAPE OR COVER ANY PART OF THE SPROCKET HOLES.
  - 7) ADJACENT LAYERS OF TAPE SHALL NOT STICK TOGETHER WHEN WOUND ON THE CARRIER REEL.
  - 8) THE TOP COVER TAPE MUST BE SECURELY ATTACHED TO THE EMBOSSSED CARRIER TAPE BY USE OF HEAT.
  - 9) EACH REEL SHALL HAVE A LABEL AFFIXED TO IT WITH THE FOLLOWING INFORMATION: PART NO., QUANTITY=200, AND DATE CODE. LABELS SHOWN FOR ILLUSTRATION ONLY. LABELS TO BE LOCATED ON SIDE OF REEL OPPOSITE THE ROUND SPROCKET HOLES.
  - 10) TAPE SPLICES ARE NOT PERMITTED.
  - 11) THE TOP COVER TAPE SHALL HAVE A TOTAL PEEL STRENGTH OF 0.1-0.7 NEWTONS WHEN PULLED OPPOSITE THE DIRECTION OF CARRIER TAPE TRAVEL. THE CARRIER AND/OR COVER TAPE SHALL BE PULLED WITH A VELOCITY OF 120±mm PER MINUTE.
  - 12) ALL DIMENSIONS ARE SHOWN FOR REFERENCE ONLY.

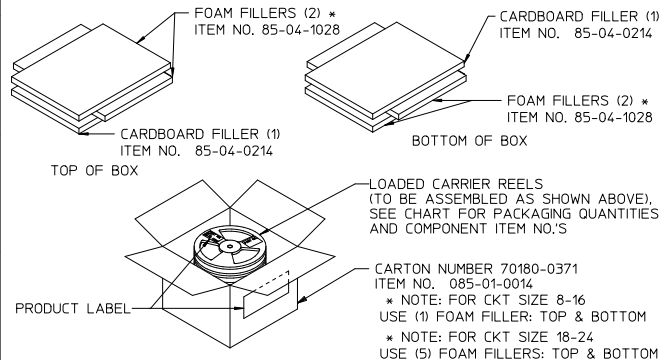
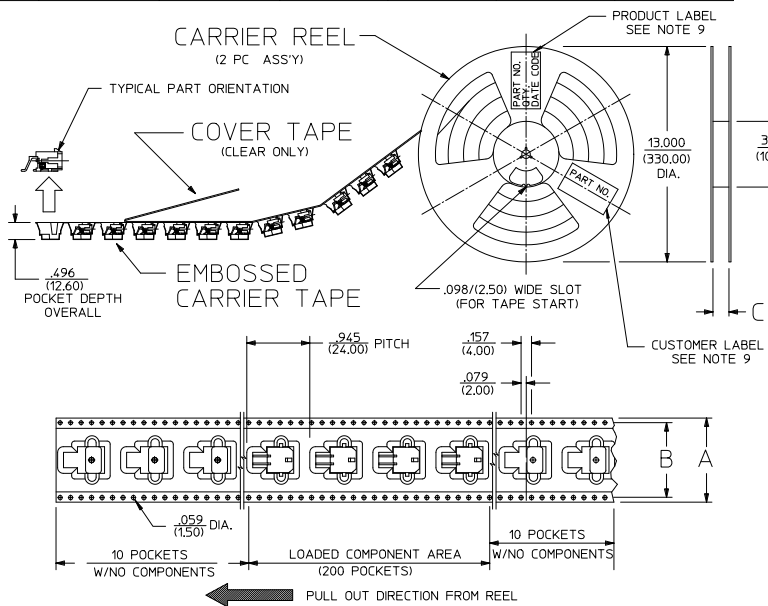

UPDATE BORDER EC NO. UEP2011-0440 DRWINGIRAVANI 2010/08/17 CHKD:SSUSEK 2010/08/17 APPRO:SMITH 2010/10/04	QUALITY SYMBOLS ▽=0 ▽=0 ▽=3	GENERAL TOLERANCES (UNLESS SPECIFIED)		DIMENSION STYLE IN/MM		SCALE ---	DESIGN UNITS INCH	THIRD ANGLE PROJECTION
		mm	INCH	DRAWN BY BAP	DATE 1996/02/08	TITLE MICRO-FIT (3.0) TAPE AND REEL SPEC. FOR R.A. SURFACE MOUNT ASSY		
		4 PLACES ±---	±---	CHECKED BY BAP	DATE 1995/02/08	MOLEX INCORPORATED		
		3 PLACES ±---	±---	APPROVED BY R.J.F.	DATE 1995/02/08	MATERIAL NO. PK-70873-05**	DOCUMENT NO.	
		2 PLACES ±---	±---	DRAFT WHERE APPLICABLE MUST REMAIN WITHIN DIMENSIONS		SEE CHART	SHEET NO. 1 OF 4	
		1 PLACE ±---	±---	THIS DRAWING CONTAINS INFORMATION THAT IS PROPRIETARY TO MOLEX INCORPORATED AND SHOULD NOT BE USED WITHOUT WRITTEN PERMISSION				