

THIS COPY IS PROVIDED ON A RESTRICTED BASIS AND IS NOT TO BE USED IN ANY WAY DETRIMENTAL TO THE INTERESTS OF PANDUIT CORP.

PANDUIT P/N	WEIGHT
NK1FN**	.62 LB/10 PCS (279.2 g/10 PCS)

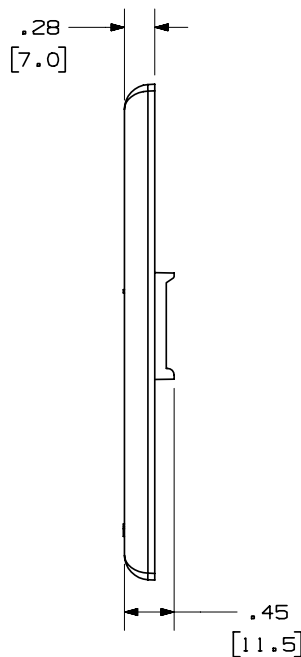
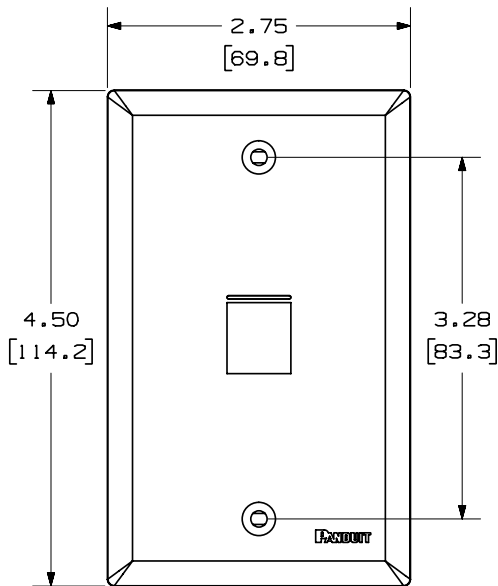

NOTES:

- SEE CURRENT CATALOG FOR ADDITIONAL PART NUMBER SUFFIXES TO INDICATE COLOR AND OR PACKAGE QUANTITY.
- SEE CATALOG FOR COMPLETE LIST OF PARTS APPLICABLE FOR USE WITH THIS PART.
- DIMENSIONS IN PARENTHESES ARE IN METRIC.
- PART INCLUDES:
  - 1- FACEPLATE
  - 2- COLOR COORDINATED MOUNTING SCREW (#6-32X 1.00")

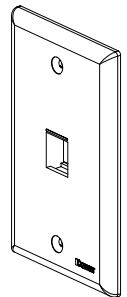

MODEL FILENAME	M02062BA_NKFP1_02.PRT	SIZE <b>A</b>
DRAWING FILENAME	M02062BA_DC_02A.PRT	

NETKEY™ 1 POSITION  
VERTICAL CLASSIC SERIES  
FACEPLATE CUSTOMER DRAWING



ALL DIMENSIONS ARE GIVEN IN INCHES, UNLESS OTHERWISE SPECIFIED.  
DIMENSIONAL TOLERANCES ARE:  
(.X) ± (.XXX) ± .010(.3)  
(.XX) ± .031(.8) ANGLES ±

THIRD ANGLE PROJECTION

DRAWN BY  
JsP

DATE  
8-16-04

REVIEW DRAWING NUMBERS  
MATERIAL: ABS

I.I. NUMBER	N/A
PRODUCT SPEC	N/A
WORK INSTRUCTION	N/A
SCALE	NONE
PART NO.	NK1FN**
DRAWING NO.	02062-04

REV	DATE	BY	CHK	DESCRIPTION	ECN	R	CUST	SUP	OTH	CHK'D
R	8-16-04	JsP		RELEASED TO PRODUCTION	02062-04					