

Smart choice for power

xantrex

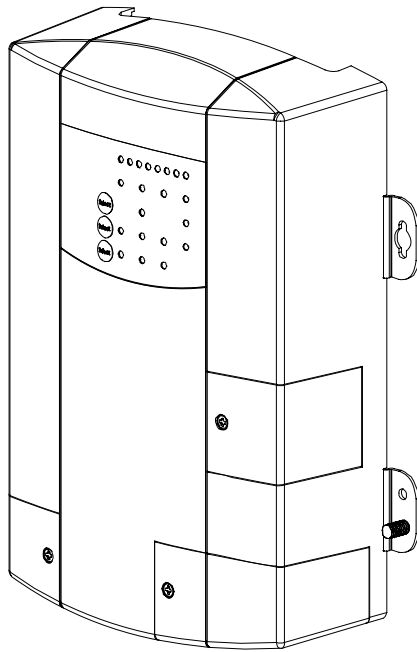

TC1012	10A-12V
TC1512	15A-12V
TC2012	20A-12V
TC3012	30A-12V
TC4012	40A-12V
TC5012	50A-12V
TC6012	60A-12V
TC1524	15A-24V
TC2024	20A-24V
TC3024	30A-24V
TC5024	50A-24V

Installation Guide

TRUECHARGE™²

Series Battery Charger

This guide for use by qualified installers only

www.xantrex.com

Truecharge™ 2 Series Battery Chargers

Installation Guide

This guide for use by qualified installers only

About Xantrex

Xantrex Technology Inc. is a world-leading supplier of advanced power electronics and controls with products ranging from small mobile units to utility-scale systems for wind, solar, batteries, fuel cells, microturbines, and backup power applications in both grid-connected and stand-alone systems. Xantrex products include inverters, battery chargers, programmable power supplies, and variable speed drives that convert, supply, control, clean, and distribute electrical power.

Trademarks

Truecharge™ 2 Series Battery Charger is a trademark of Xantrex International. Xantrex is a registered trademark of Xantrex International.

Other trademarks, registered trademarks, and product names are the property of their respective owners and are used herein for identification purposes only.

Notice of Copyright

Truecharge™ 2 Series Battery Charger Installation Guide © September 2008 Xantrex International. No part of this document may be reproduced in any form or disclosed to third parties without the express written consent of:

Xantrex International
Suite #3, Stafford House, The Garrison,
St. Michael, Barbados

Xantrex International reserves the right to revise this document and to periodically make changes to the content hereof without obligation or organization of such revisions or changes unless required to do so by prior arrangement.

Exclusion for Documentation

UNLESS SPECIFICALLY AGREED TO IN WRITING, XANTREX TECHNOLOGY INC. ("XANTREX™")

(A) MAKES NO WARRANTY AS TO THE ACCURACY, SUFFICIENCY OR SUITABILITY OF ANY TECHNICAL OR OTHER INFORMATION PROVIDED IN ITS MANUALS OR OTHER DOCUMENTATION.

(B) ASSUMES NO RESPONSIBILITY OR LIABILITY FOR LOSSES, DAMAGES, COSTS OR EXPENSES, WHETHER SPECIAL, DIRECT, INDIRECT, CONSEQUENTIAL OR INCIDENTAL, WHICH MIGHT ARISE OUT OF THE USE OF SUCH INFORMATION. THE USE OF ANY SUCH INFORMATION WILL BE ENTIRELY AT THE USER'S RISK; AND

(C) REMINDS YOU THAT IF THIS MANUAL IS IN ANY LANGUAGE OTHER THAN ENGLISH, ALTHOUGH STEPS HAVE BEEN TAKEN TO MAINTAIN THE ACCURACY OF THE TRANSLATION, THE ACCURACY CANNOT BE GUARANTEED. APPROVED XANTREX CONTENT IS CONTAINED WITH THE ENGLISH LANGUAGE VERSION WHICH IS POSTED AT WWW.XANTREX.COM.

Date and Revision

September 2008 Rev B

Document Part Number

975-0402-01-01

Product Numbers

804-1210, 804-1215, 804-1220, 804-1230, 804-1240, 804-1250, 804-1260, 804-2415, 804-2420, 804-2430, 804-2450

Contact Information

Telephone: 1 800 670 0707 (toll free North America)
1 408 987 6030 (direct)
+34 93 470 5330 (Europe)

Fax: 1 800 994 7828 (toll free North America)
+34 93 473 6093 (Europe)

Email: customerservice@xantrex.com

Web: www.xantrex.com

This guide for use by qualified installers only

About This Guide

Purpose

The purpose of this Installation Guide is to provide explanations and procedures for installing and configuring the Truecharge™ 2 Series Battery Charger.

Scope

The Guide provides safety guidelines, procedures for installing the battery charger, as well as information on configuring the battery charger. It does not provide details about particular brands of batteries. You need to consult individual battery manufacturers for this information.

Refer to Truecharge™ 2 Battery Charger Owner's Guide (doc. part number: 975-0401-01-01) for operational instructions.

Audience

The Guide is intended for qualified installers who need to install and configure any unit model of the Truecharge™ 2 Series Battery Charger. The installer should be a qualified technician or electrician with knowledge and experience in installing electrical equipment, knowledge of the applicable installation codes, and awareness of the hazards involved in performing electrical work and how to reduce those hazards.

Organization

This Guide is organized into two chapters and one appendix. Chapter 1 describes the standard features of a Truecharge™ 2 Battery Charger, as well as its protection features. It also provides information on the different parts of the Truecharge™ 2 Battery Charger including information on the optional remote panel.

Chapter 2 provides procedures for installing, testing and configuring the Truecharge™ 2 Battery Charger.

Appendix A contains physical, electrical performance, and regulatory approval specifications for the Truecharge™ 2 Battery Charger.

Conventions Used

The following conventions are used in this guide.



WARNING

Warnings identify conditions or practices that could result in personal injury or loss of life.



CAUTION

Cautions identify conditions or practices that could result in damage to the unit or other equipment.

Important: These notes describe things which are important for you to know, but not as serious as a caution or warning.

This Guide contains information for 11 product models of the Truecharge™ 2 Series Battery Charger.

The 12 Vdc models are: TC1012, TC1512, TC2012, TC3012, TC4012, TC5012, and TC6012. When being referred to individually, the product will be referred to by its model name.

The 24 Vdc models are: TC1524, TC2024, TC3024, and TC5024. When being referred to individually, the product will be referred to by its model name.

When all models are being referred to, they will be referred to as Truecharge™ 2 Battery Chargers.

Related Information

You can find more information about Xantrex Technology Inc. as well as its products and services at www.xantrex.com

Important Safety Instructions

READ AND SAVE THIS INSTALLATION GUIDE FOR FUTURE REFERENCE.

This chapter contains important safety, installation, and operating instructions for the Truecharge™ 2 Series Battery Chargers.

1. Before installing and using a Truecharge™ 2 Battery Charger, read all instructions and cautionary markings on a Truecharge™ 2 Battery Charger unit, the batteries, and all appropriate sections of this guide.



WARNING: Risk of injury

To reduce the risk of injury, charge only properly rated (such as 12 V and 24 V) lead-acid (GEL, AGM, Flooded, or lead-calcium) rechargeable batteries. Other battery types may burst, causing personal injury and damage.

-
2. Do not expose the Truecharge™ 2 Battery Charger to rain, snow, spray, or bilge water. To reduce risk of fire hazard, do not cover or obstruct the air intake vent openings. Do not install the Truecharge™ 2 Battery Charger in a zero-clearance compartment. Overheating may result.
 3. This appliance is not intended for use by persons (including children) with reduced physical, sensory, or mental capabilities or lack of experience and knowledge, unless they have been given supervision or instruction concerning use of the appliance by a person responsible for their safety. Children should be supervised to ensure that they do not play with the appliance.

4. To avoid a risk of fire and electric shock, make sure that all wiring is in good condition and is not undersized. Do not operate the Truecharge™ 2 Battery Charger with damaged or substandard wiring.
5. Do not operate the Truecharge™ 2 Battery Charger if it has received a sharp blow, been dropped, has cracks or openings in the enclosure including if the fuse cover has been lost, damaged, or will not close, or otherwise damaged in any other way. If the Truecharge™ 2 Battery Charger is damaged, see the Warranty section under Truecharge™ 2 Battery Charger Owner's Guide (doc. part number: 975-0401-01-01).
6. Do not disassemble the Truecharge™ 2 Battery Charger—there are hazardous voltages within. It contains no user-serviceable parts. See the Warranty section under Truecharge™ 2 Battery Charger Owner's Guide (doc. part number: 975-0401-01-01) for instructions on obtaining service. Attempting to service the Truecharge™ 2 Battery Charger yourself may result in a risk of electrical shock or fire and will void the warranty. Internal capacitors remain charged after all power is disconnected.
7. To reduce the risk of electrical shock, disconnect both AC and DC power from the Truecharge™ 2 Battery Charger before attempting any maintenance or cleaning or working on any circuits connected to the Truecharge™ 2 Battery Charger. Turning off using the on/standby button on the remote panel will not reduce this risk.
8. The Truecharge™ 2 Battery Charger must be provided with equipment-grounding conductors connected to the AC input ground and to the DC chassis ground.

**WARNING: Explosion hazard**

9. Working in the vicinity of lead-acid batteries is dangerous. Batteries generate explosive gases during normal operation. Therefore, it is of utmost importance that you read this manual and follow the instructions exactly each time you use the charger.
10. To reduce the risk of battery explosion, follow these instructions and those published by the battery manufacturer and the manufacturer of any equipment you intend to use in the vicinity of the battery. Review cautionary markings on these products and on the engine.

Personal Precautions When Working With Batteries

**WARNING: BATTERIES PRESENT RISK OF ELECTRICAL SHOCK, BURN FROM HIGH SHORT-CIRCUIT CURRENT, FIRE OR EXPLOSION FROM VENTED GASES. OBSERVE PROPER PRECAUTIONS.**

1. Have someone within range of your voice or close enough to come to your aid when you work near a lead-acid battery.
2. Have plenty of fresh water and soap nearby in case battery acid contacts skin, clothing, or eyes.
3. Wear proper, non-absorbent gloves, complete eye protection, and clothing protection. Avoid touching your eyes and wiping your forehead while working near batteries.

4. If battery acid contacts skin or clothing, wash immediately with soap and water. If acid enters your eye, immediately flood it with running cold water for at least twenty minutes and get medical attention immediately.
5. Never smoke or allow a spark or flame near the engine or batteries.
6. Use extra caution to reduce the risk of dropping a metal tool on the battery. It could spark or short circuit the battery or other electrical parts and could cause an explosion.
7. Remove all personal metal items, like rings, bracelets, and watches when working with batteries. Batteries can produce a short circuit current high enough to weld a ring or metal bracelet or the like to the battery terminal, causing a severe burn.
8. If you need to remove a battery, always remove the negative terminal from the battery first for systems with grounded negative. If it is grounded positive, remove the positive terminal first. Make sure all loads connected to the battery and all accessories are off so you don't cause an arc.
9. Never charge a frozen battery.

PREPARING TO CHARGE

10. Make sure the area around the battery is well ventilated.
11. Make sure the voltage of the batteries matches the output voltage of the battery charger.
12. Clean battery terminals. Be careful to keep corrosion from coming into contact with your eyes and skin.
13. Study and follow all of the battery manufacturer's specific precautions, such as removing or not removing cell caps while charging, whether equalization is acceptable for your battery, and recommended rates of charge.

14. For flooded non-sealed batteries, add distilled water in each cell until battery acid reaches the level specified by the battery manufacturer. This helps to purge excessive gas from cells. Do not overfill. For a battery without removable cell caps, carefully follow manufacturer's instructions.

BATTERY CHARGER LOCATION

15. Locate the Truecharge™ 2 Battery Charger unit away from batteries in a well ventilated compartment.
16. Never place the Truecharge™ 2 Battery Charger unit directly above batteries; gases from a battery will corrode and damage the charger
17. Never allow battery acid to drip on the charger when reading gravity, or filling battery.
18. Do not operate the charger in a closed in area, or restrict the ventilation in any way.
19. Do not place a battery on top of the charger.
20. For North American marine installations, external connections to the charger shall comply with the United States Coast Guard Electrical Regulations (33CFR183, Sub Part I).

FCC Information to the User

This equipment has been tested and found to comply with the limits for a Class B digital device, pursuant to part 15 of the FCC Rules. These limits are designed to provide reasonable protection against harmful interference in a residential installation. This equipment generates, uses, and can radiate radio frequency energy and, if not installed and used in accordance with the instructions, may cause harmful interference to radio communications.

However, there is no guarantee that interference will not occur in a particular installation. If this equipment does cause harmful interference to radio or television reception, which can be determined by turning the equipment off and on, the user is encouraged to try to correct the interference by one or more of the following measures:

- Reorient or relocate the receiving antenna.
- Increase the separation between the equipment and receiver.
- Connect the equipment into an outlet on a circuit different from that to which the receiver is connected.

Consult the dealer or an experienced radio/TV technician for help.

Contents

Important Safety Instructions	vii
-------------------------------	-----

1 Introduction

Truecharge™ 2 Battery Charger	1-1
Standard and Protection Features	1-2
Truecharge™ 2 Battery Charger	1-4
Rear Panel	1-6

2 Installation

Preparing for Installation	2-2
Tools and Materials	2-4
Location	2-5
Wiring Requirements	2-8
DC Wiring	2-8
AC Wiring	2-10
Battery Bank Size Requirements	2-12
Installing the Truecharge™ 2 Battery Charger	2-13
Installation Sequence	2-13
Mounting the Truecharge™ 2 Battery Charger	2-14
Connecting the DC Chassis Ground (Earth)	2-15
Installing DC Wiring	2-16
Installing AC Wiring	2-20
Powering Up	2-24
Installing Optional Accessories	2-25
Installing the Optional Battery Temperature Sensor (BTS)	2-25
Mounting the Optional Remote Panel	2-26

Contents

Configuring the Truecharge™ 2 Battery Charger- - - - -	2-27
Configuring the Charger Mode - - - - -	2-27
Configuring the Battery Bank Type - - - - -	2-29
Configuring the Maximum Output Current Percentage - - - - -	2-30
Installing Batteries - - - - -	2-31

A Specifications

Physical Specifications - - - - -	A-2
Electrical Specifications - - - - -	A-3
AC Input Specifications - - - - -	A-3
DC Output Specifications - - - - -	A-4
Environmental Specifications - - - - -	A-5
Protection Features - - - - -	A-6
Approvals - - - - -	A-7

1

Introduction

Chapter 1 describes the standard features of a Truecharge™ 2 Battery Charger, as well as its protection features. It also provides information on the different parts of the Truecharge™ 2 Battery Charger.

Truecharge™ 2 Battery Charger

The Truecharge™ 2 Battery Charger ships with the following items.

- one Truecharge™ 2 Battery Charger unit
- installation and operation guides
- rubber boots for DC terminals
- nuts and washers
- strain relief clamp for AC input cables
- three crimp connectors for AC wiring

Note: Keep the carton and packing material in case you need to return the Truecharge™ 2 Battery Charger for servicing.

This guide for use by qualified installers only

Standard and Protection Features

The Truecharge™ 2 Battery Charger provides the following standard features:

- three¹ full current rated outputs
- battery monitoring functions while in float mode or rest mode
- correct charging voltage for batteries when connected to almost any single phase AC power outlet in the world
- low electromagnetic interference (EMI)
- automatic charge resumption, if required, after AC power interruption
- programmable custom charge settings²
- fully discharged battery charging³

The Truecharge™ 2 Battery Charger provides the following protection features:

- battery reverse polarity protection via a replaceable output fuse
- AC input out-of-range derating and shutdown
- ambient over temperature derating and shutdown
- battery over-charging protection
- electronic current limiting provides protection against short circuit conditions on the charger's output
- ignition protected rating, enabling installation in engine spaces
- isolated design

1. Model TC1012 has one output and model TC1512 has two outputs. All other models have three outputs. Each output (for models with 2 or 3 outputs) can charge different batteries that either have the same chemistry or can tolerate the same charge sequence.

2. The charger can be programmed with custom charge setpoints using PC interface. This programming can only be done using a special configuration tool operated by Xantrex or a designated OEM.

3. The charger can initiate charging a non-damaged but zero voltage battery.

- short circuit protection for the BTS and communication connector ports including protection from incorrectly inserting the remote panel communication cable plug into the BTS port and vice versa
- drip-proof rubber boots for DC terminals for added moisture protection
- IP-32 drip protection rating¹
- locked fan² protection

The Truecharge™ 2 Battery Charger provides the following optional features:

- an optional remote panel³ which can be mounted up to 15 m (50 ft) away for remote control and monitoring.
- an optional battery temperature sensor⁴ (BTS) provides battery temperature voltage compensation from 0 to 70 °C (-13 to 158 °F)

The optional Battery Temperature Sensor (BTS) provides these protection features:

- battery under temperature charging protection preventing battery charging at -25 °C or below
- battery over temperature charging protection preventing battery charging at 70 °C or higher
- charging voltage compensation based on the temperature of the battery the optional BTS is connected to

1. In two specific installation orientations—see Figure 2-2, “Truecharge™ 2 Battery Charger Mounting Orientations” on page 2–7.

2. A locked fan occurs when the fan’s blades are hindered from turning by objects such as insects or accumulated debris that can obstruct the fan’s operation. The Truecharge™ 2 Battery Charger sounds an alarm if the fan suddenly stops turning. If the fan does not resume turning after a minute, the charger reports a fault and immediately stops charging.

3. Part number: 808-8040-00

4. Part number: 808-0232-01

Truecharge™ 2 Battery Charger

This section describes the different parts of the Truecharge™ 2 Battery Charger.

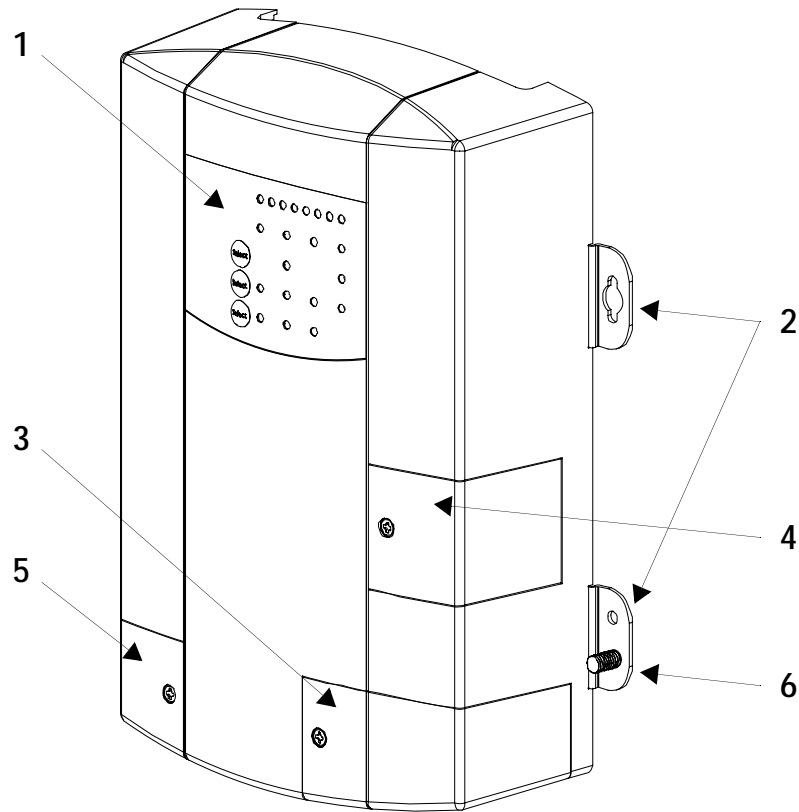



Figure 1-1 Truecharge™ 2 Battery Charger

Item	Description
1	Onboard control and status display panel or simply onboard display (see “Rear Panel” on page 1–6 for more information) for controlling the Truecharge™ 2 Battery Charger settings and for monitoring charger status and charging current.
2	Mounting flanges are used to permanently install the product.
3	DC wiring compartment cover protects the DC terminals, as well as the communication and BTS ports. Remove and replace when installing cables.

Item	Description
4	<p data-bbox="553 268 1321 384">Fuse access panel cover provides access to the DC fuse in the event of an accidental reverse battery polarity installation.</p> <p data-bbox="565 443 1187 520"> WARNING: Shock hazard</p> <p data-bbox="553 552 1308 625">Disconnect the batteries and AC power before opening the fuse access panel.</p>
5	<p data-bbox="553 657 1321 814">AC wiring compartment cover provides the installer with easy access to the AC wiring compartment, to allow for a trouble free installation. Remove and replace when installing the product.</p>
6	<p data-bbox="553 846 1321 919">DC ground stud for connecting the charger's chassis to ground.</p>

Rear Panel

This section describes the parts of the rear panel of the Truecharge™ 2 Battery Charger.

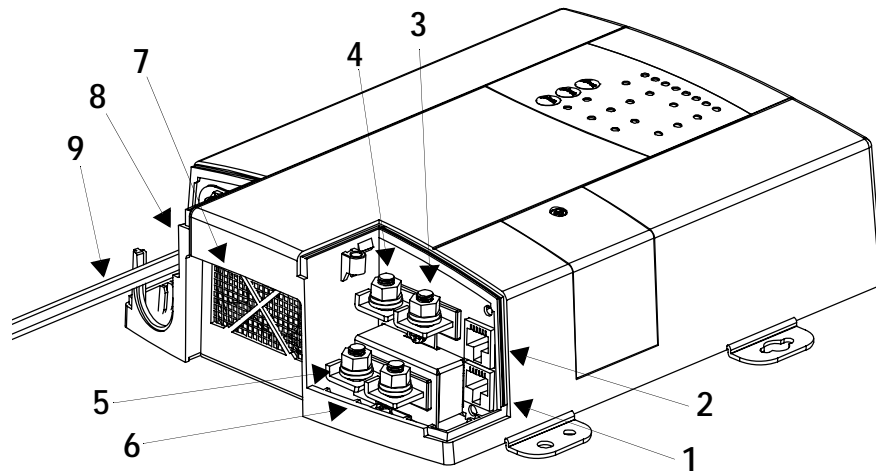

40 A model (TC4012) shown. Other models may vary.

Figure 1-2 Truecharge™ 2 Battery Charger Rear Panel

Item	Description
1	BTS port - battery temperature sensor port
2	Communication port - remote panel port
3	Battery positive (+) for bank 3 (6 mm stud)
4	Battery positive (+) for bank 2 (6 mm stud)
5	Battery positive (+) for bank 1 (6 mm stud)
6	Battery negative (-) , common for all three banks (6 mm stud) (common for both banks in model TC1512) (model TC1012 has a single bank only—one positive terminal and one negative terminal)
7	Air intake vent - located inside is the fan assembly
8	AC wiring compartment
9	AC pigtail wiring - line, neutral, and ground input wires

Please see the Truecharge™ 2 Battery Charger Owner's Guide (doc. part number: 975-0401-01-01) for information on the following:

1. Onboard Control and Status Display Panel
2. Fault and Warning Indicators
3. Remote Panel

2 Installation

Chapter 2 provides procedures for installing, testing and configuring the Truecharge™ 2 Battery Charger.

It covers the following major topics:

- “Preparing for Installation” on page 2–2.
- “Installing the Truecharge™ 2 Battery Charger” on page 2–13
- “Installing Optional Accessories” on page 2–25
- “Configuring the Truecharge™ 2 Battery Charger” on page 2–27
- “Installing Batteries” on page 2–31

This guide for use by qualified installers only

Preparing for Installation



WARNING

The battery charger must be installed by a qualified installer in accordance with all applicable local or national installation codes. Examples of such codes are the US National Electrical Code (NFPA 70), the American Boat and Yacht Council standards E-11 and A-31, and the US Coast Guard Electrical Regulations (33CFR183).

The Truecharge™ 2 Battery Charger is designed to be permanently mounted. Figure 2-1 shows a typical installation with three batteries, a battery temperature sensor (BTS) and a remote panel (both optional). It also shows the AC and DC wiring and protection devices required for a typical installation. Means of over-current protection and disconnection must be incorporated into the fixed wiring, in accordance with the electrical code that governs each installation.

NOTE: Not to scale. For illustration purposes only.

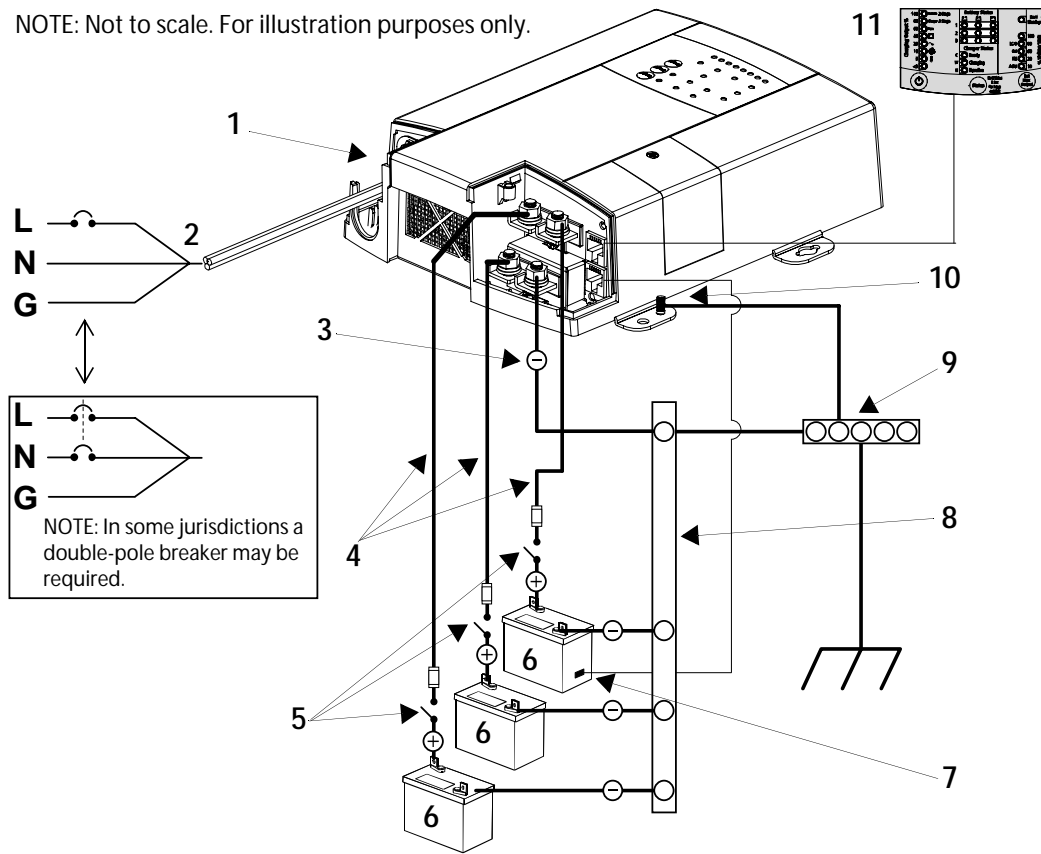

Figure 2-1 Typical Truecharge™ 2 Battery Charger System Installation

1	AC mains source protected by correct size and type of branch rated circuit breaker
2	AC input wiring compartment
3	DC negative cable
4	DC positive cables
5	DC circuit breakers or DC fused disconnects
6	Battery or battery bank
7	Battery Temp. Sensor (optional accessory part number: 808-0232-01)
8	Engine ground bus or DC negative bus
9	Ground bus
10	DC chassis ground (earth)
11	Remote panel (optional accessory part number: 808-8040-00)

Tools and Materials

To mount and connect the Truecharge™ 2 Battery Charger you need the following tools:

- 10 mm socket wrench and extension for the DC terminals and ground stud
- Phillips screwdriver for removing and re-securing the AC and DC wiring compartment covers
- power drill/screwdriver
- drill bit for pilot holes for mounting screws (if using #6 mounting screws, use 1/16 drill)
- wire stripper
- manufacturer's recommended crimp tool for any crimp terminals that are being used

You need the following materials:

- 3 conductor AC input wiring
Use the information in “Installing AC Wiring” on page 2–20 and your local electrical codes to determine the correct wire and breaker or fuse.
- AC cable strain relief (if the one included is not compliant with your local electrical code requirements)
- appropriately sized DC cables for each battery, with suitable connectors at the battery end
Use the information in “DC Wiring” on page 2–8 and your local electrical codes to determine the correct wire and breaker or fuse.
- appropriately sized DC chassis ground (earth) with suitable connectors
- ring terminals to fit 6 mm (1/4 in.) studs at the charger end (Marine grade hardware is recommended).
- DC fused disconnect or properly rated circuit breaker for each battery bank
- mounting screws, M3 or #6 marine grade, corrosion resistant (4 pieces) (Length dependent on mounting surface).

Location

Install the Truecharge™ 2 Battery Charger in a location that meets the following requirements:

Condition	Requirement
Dry	The Truecharge™ 2 Battery Charger must be installed in a dry location not subject to moisture especially rain, spray, or splashing bilge water.
Clean	The Truecharge™ 2 Battery Charger should not be exposed to metal filings or any other form of contamination.
Cool	The ambient air temperature should be between 0 °C - 50 °C (32 °F - 122 °F) for best performance.
Ventilated	There must be at least 10 cm (4 in.) of clearance on the top and bottom ends of the Truecharge™ 2 Battery Charger for air flow and at least 6 cm (2.5 in.) of clearance on either side (see Figure 2-3). Ventilation openings on the charger must not be obstructed. If the charger is mounted in a tight fitting compartment, the compartment must be ventilated with cut-outs to prevent the charger overheating.
Safe	This battery charger is ignition protected, so it can be installed in areas containing gasoline tanks or fittings which require ignition protected equipment. Xantrex recommends, however, that it is safest not to install electrical equipment in these areas.
Close to batteries	The Truecharge™ 2 Battery Charger should be installed as close as possible to the batteries, but not in the same compartment to prevent corrosion. Avoid excessive cable lengths and use the recommended wire sizes. Xantrex recommends installing with cables sized to achieve less than 3% voltage drop on battery cables under full load. This will maximize the performance of the charger.

When planning to install the Truecharge™ 2 Battery Charger, be sure that you consider the location and orientation carefully. The Truecharge™ 2 Battery Charger is considered to have an IP rating of IP-32, if installed in either of two specific orientations [shown in Figure 2-2 a) and b)]. This rating means that it meets standards to prevent dripping water from entering the enclosure, and causing shock hazard and damage to equipment.

The other possible mounting orientations will not prevent the entry of dripping water, and are not suitable for marine or other moist environments without the installation of additional drip protection. They are only acceptable for use in locations that are always dry [shown in Figure 2-2 c) and d)].

The environment, therefore, will determine the mounting orientations that are suitable for each installation. Is the installation environment one that will always be dry or will moisture or condensation sometimes enter the area?



WARNING: Shock hazard

In marine environments, there is a likelihood that condensation will be present, and may drip on to the charger. Use the appropriate mounting orientations as shown in Figure 2-2.

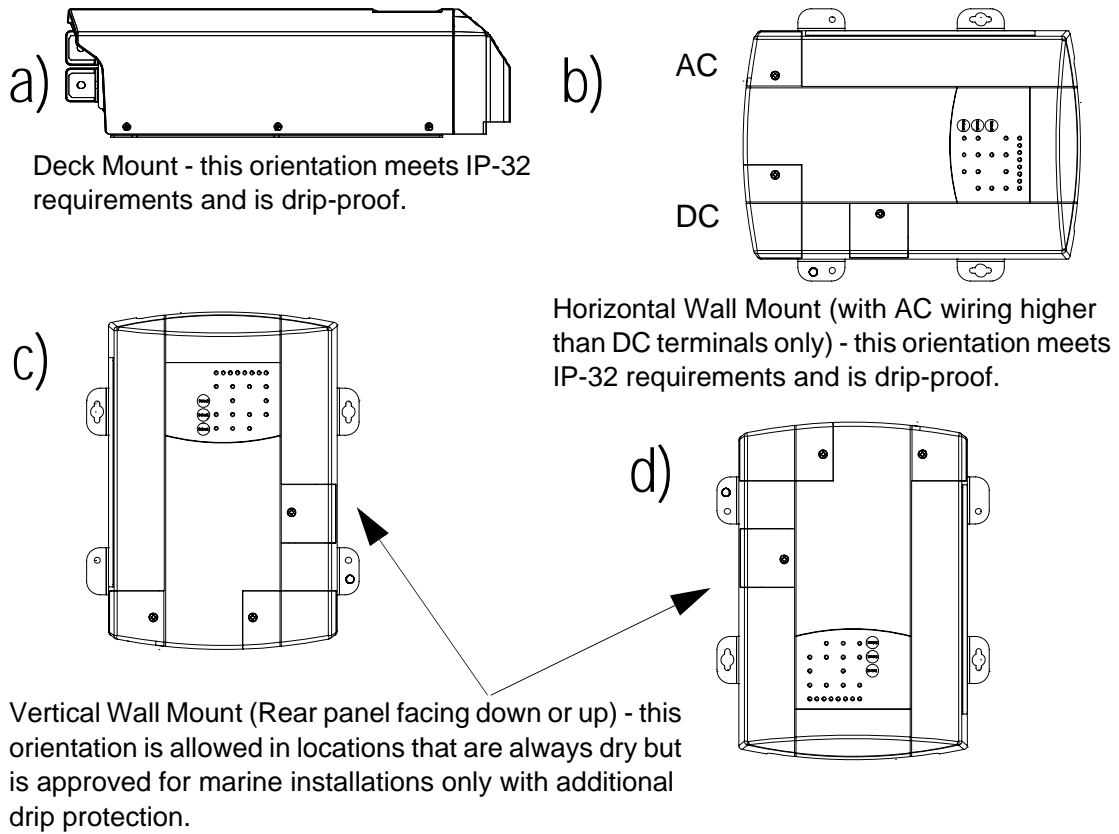

Figure 2-2 Truecharge™ 2 Battery Charger Mounting Orientations

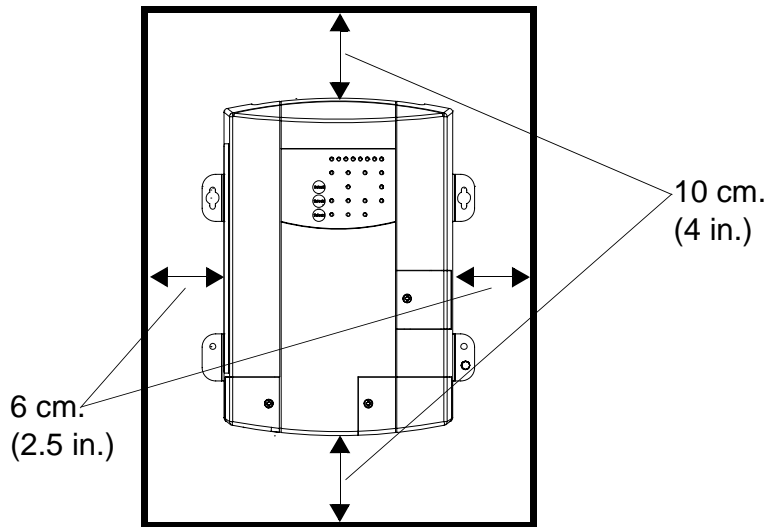

Figure 2-3 Ventilation Clearance

Wiring Requirements



WARNING: Shock and fire hazard

Wiring and fuse sizes are governed by electrical codes and standards. Different requirements apply in different countries and to different types of installations, for example, boat, home or RV. It is the responsibility of the installer to ensure that each installation complies with all applicable codes and standards.



WARNING: Shock and fire hazard

Ensure that wires and fuses or breakered disconnects are correctly sized.

Maximum continuous current available from the charger may be an additional 6–10% above the nominal current rating of the charger.

DC Wiring

The following two tables show some typical wire sizes for various cable length runs, based on 3% voltage drop on DC cables, 75 °C (167 °F) rated wire with wiring being inside the engine compartment – assumed ambient of 50 °C (122 °F).

Table 2-1 DC Wiring Examples for 12 V chargers^a

Wire Length (max length one way)		Wire Size (AWG and mm ²)						
		TC1012	TC1512	TC2012	TC3012	TC4012	TC5012	TC6012
feet	meters							
5	1.5	No. 14 2 mm ²	No. 12 3.3 mm ²	No. 10 5.3 mm ²	No. 10 5.3 mm ²	No. 8 8.4 mm ²	No. 6 13.3 mm ²	No. 6 13.3 mm ²
7.5	2.25	No. 12 3.3 mm ²	No. 10 5.3 mm ²	No. 10 5.3 mm ²	No. 8 8.4 mm ²	No. 6 13.3 mm ²	No. 6 13.3 mm ²	No. 4 21.2 mm ²
20	6	No. 8 8.4 mm ²	No. 6 13.3 mm ²	No. 6 13.3 mm ²	No. 4 21.2 mm ²	No. 2 33.6 mm ²	No. 2 33.6 mm ²	No. 1 42.4 mm ²

a. Values based on American Boating and Yachting Council E-11 2008 Table VI-A and Table IX.

Table 2-2 DC Wiring Examples for 24 V chargers^a

Wire Length (max length one way)		Wire Size (AWG and mm ²)			
		TC1524	TC2024	TC3024	TC5024
feet	meters				
5	1.5	No. 14 2 mm ²	No. 10 5.3 mm ²	No. 10 5.3 mm ²	No. 6 13.3 mm ²
7.5	2.25	No. 14 2 mm ²	No. 10 5.3 mm ²	No. 10 5.3 mm ²	No. 6 13.3 mm ²
20	6	No. 10 5.3 mm ²	No. 8 8.4 mm ²	No. 6 13.3 mm ²	No. 4 21.2 mm ²

a. Values based on American Boating and Yachting Council E-11 2008 Table VI-A and Table IX.

Over-current protection disconnect

Electrical codes require the DC circuit from each battery to the charger to be equipped with a disconnect and an over-current protection device, usually within 7 inches (17.8 cm) of each battery¹. The devices are usually DC-rated circuit breakers, fused disconnects, or a separate fuse and disconnect for each circuit. These devices must be rated for DC voltage and current and be rated to withstand the short circuit current available from the connected battery bank. Do not substitute devices rated only for AC voltage; they may not operate properly.

The current rating of the DC fuses must be correctly matched to the size of the DC wiring used, in accordance with the applicable codes. This helps to protect the installation against fire in case of any overcurrent or short circuit fault.

1. Per American Boating and Yachting Council E-11.

Table 2-3 Fuse Sizes versus Wire Sizes Based on ABYC Regulations

AWG	Max. Fuse/Breaker
14	15 A
12	20 A
10	30 A
8	50 A
6	80 A
4	100 A
2	125 A
1	150 A

The DC chassis ground (earth) wire should also be sized correctly to provide proper protection. Refer to the local electrical codes for your specific installation to determine the correct gauge. The ABYC standards require this DC chassis ground wire to be the same size as the largest DC + and – conductors connected to the charger, or no more than one wire size smaller.

AC Wiring



WARNING: Risk of fire

Use only on circuits provided with 20A maximum branch circuit protection in accordance with National Electrical Code, NFPA 70.

The AC wiring must be of sufficient size, and it must be protected by the appropriate size and type of input breaker, based on the jurisdiction and application. Some basic examples are given below.

The AC input wiring for the Truecharge™ 2 Battery Charger should be three-conductor cable, providing a line, neutral, and ground conductor (or L, N, GND) in an outer jacket, rated

a minimum of 75C, and sized based on the AC input current to the charger (see Appendix A) and on the value of overcurrent protection provided.

For example, in US NEC, you may use a 14 AWG wire with a 15 A breaker for up to 12 A continuous current (or 12 AWG for a 20 A breaker for up to 16 A continuous current) or for 230 Vac application, you may be able to use either a 2.5mm² wire with a 16 A breaker or use 1.5 mm² wire with a 10 A breaker. Note that every jurisdiction will have different requirements as will each application, so research the regulations for your local jurisdiction to determine which wire size and type is correct based on the maximum AC input current marked on the chargers and given in Appendix A.

Wire Types:

- for marine applications, the United States American Yachting and Boating Council (ABYC) requires stranded wire, which is more robust than solid wire when exposed to vibration
- for RV applications, the United States National Electrical Code (NEC) allows solid wire in multi-conductor cable, however, stranded wire is also acceptable which will withstand vibration better.

The AC wiring supplying the Truecharge™ 2 Battery Charger must be protected by the correct size and type of branch-circuit rated fuse or breaker to meet the applicable installation codes. If a fuse is used instead of a breaker, a correctly rated disconnect switch is required ahead of the fuse so that power can be turned off, allowing fuse replacement and safe maintenance of other equipment on the mains circuit.

Battery Bank Size Requirements

The Truecharge™ 2 Battery Charger is designed to work with a minimum battery bank size. Each bank should meet the minimum Ah rating shown in Table 2-4.

Note: If the battery manufacturer has specified the maximum charge current, please follow their recommendation.

Table 2-4 Minimum Battery Bank Size

12 Vdc Models	Minimum Battery Bank Size (Ah)
TC1012	30
TC1512	30
TC2012	80
TC3012	80
TC4012	80
TC5012	100
TC6012	100
24 Vdc Models	Minimum Battery Bank Size (Ah)
TC1524	30
TC2024	50
TC3024	60
TC5024	100

Installing the Truecharge™ 2 Battery Charger



WARNING: Shock and Energy Hazards

Be sure to read the safety guidelines and pay attention to all cautions and warnings throughout the installation procedure. The installer is responsible for ensuring compliance with the installation codes for your particular application.

Disconnect all sources of AC and DC power before proceeding.

Installation Sequence

To make charger installation quick and easy, Xantrex recommends that the installation tasks be performed in the following sequence:

1. Mount the charger in position.
2. Connect the DC ground.
3. Install DC wiring including installing required disconnects, fuses, or breakers.
4. Install AC wiring including earth grounds.
5. Power up the charger.

Mounting the Truecharge™ 2 Battery Charger

Mount the Truecharge™ 2 Battery Charger using all four mounting slots and holes which are provided. Mounting orientations a) and b) in Figure 2-2 meet IP-32 and drip-proof requirements that are needed to ensure safety in the presence of condensation. The other possible mounting orientations c) and d) also shown in Figure 2-2 will not prevent the entry of dripping water, and are not suitable for use in marine installations or other moist environments without the installation of additional drip protection. They are only acceptable for use in locations that are always dry.

To mount the Truecharge™ 2 Battery Charger:

1. Select a mounting surface that is flat and allows for a minimum of 10 cm (4 in.) of clearance on the top and bottom ends for air flow and at least 6 cm (2.5 in.) of clearance on either sides (see Figure 2-3, “Ventilation Clearance” on page 2–7).
2. Drill the four pilot holes for the mounting screws, taking care that there is nothing behind the surface that can be damaged by the drill.
3. Mount the Truecharge™ 2 Battery Charger using corrosion resistant, #6 (3 mm) round, pan head (or similar) screws.

The top two keyhole-style mounting holes can be used to hold the Truecharge™ 2 Battery Charger in place while fastening the bottom two screws. For secure, permanent mounting, use the holes in all four mounting flanges and fasten all four screws. Do not rely on screws only in the keyhole slots for the installation of the charger.

Connecting the DC Chassis Ground (Earth)



WARNING: Electric shock hazard

Have an electrician install a properly grounded circuit if one is not available. Improper connection can result in risk of electric shock.

The Truecharge™ 2 Battery Charger Battery Charger must be connected to a grounded, metal, permanent wiring system, or an equipment-grounding conductor should be run with the circuit conductors and connected to the equipment-grounding lead on the charger. Connections to the battery charger must comply with all local and application-specific codes and ordinances.

Xantrex recommends that you install a DC chassis ground (earth) wire from the ground stud on the Truecharge™ 2 Battery Charger to the engine bus or DC ground bus. The DC chassis ground (earth) wire should be sized correctly with the power conductors, and both must be sized for the battery fuses that are used to protect the DC wiring. Refer to your local electrical codes to verify the requirements in your jurisdiction for your application.

To connect the DC chassis ground (earth):

1. Locate the ground stud on the Truecharge™ 2 Battery Charger.
2. Connect the DC chassis ground (earth) from the ground stud to the ground bus. See Figure 2-1, “Typical Truecharge™ 2 Battery Charger System Installation” on page 2–3.
Use a flat washer, a lock washer and a nut (included in the installation kit) to secure the connection.
3. Tighten the nuts to 2.3 N-m (20 lb-in.) torque and test that the wire is secure. Do not over-tighten as this may result in damage to the charger.

Installing DC Wiring

The procedure for installing the DC wiring applies to a single battery, as well as multiple batteries or battery banks.



WARNING: Energy and explosion hazard

To help prevent accidental shorts or sparks, leave the DC disconnects or breakers in the Off position or DC fuses removed from their fuse holders until installation is complete.

1. Plan the route that the DC wires will follow, keeping it as short as possible. Measure and cut the required wire length, after allowing some extra length for connections and to provide slack in the wires for strain relief.
2. Identify the positive wires, by using color-coded wire, or by marking both ends of the wire with colored tape, or similar kind of marking. Repeat with a different color for the negative. Most installation codes recommend coloring the positive red and the negative black.

Important: You may find it helpful to label each cable, associating it with the battery bank it is connected to. For example, bank 1 (-), bank 1 (+), bank 2 (-), and so on.

3. Install a DC circuit breaker or fused disconnect in each positive cable that is as close to the battery positive terminal as possible.
Consult your local electrical codes regarding the distance allowed between the battery and the fuse or breaker. For example, for most situations ABYC standard E-11 requires no more than 7 inches (17.8 cm). Be sure the breaker or fused disconnect is open.
4. Route the wiring to the batteries and to the Truecharge™ 2 Battery Charger. Avoid routing wiring through an electrical distribution panel, battery isolator, or other device that will add voltage drops.



WARNING: Shock hazard

The rubber boots must be installed over the Truecharge™ 2 Battery Charger DC terminals to keep water off of live parts and to maintain the chargers' IP-32 and drip-proof ratings.

5. Insert and slide the rubber boot(s) over the charger end of the DC battery cables.

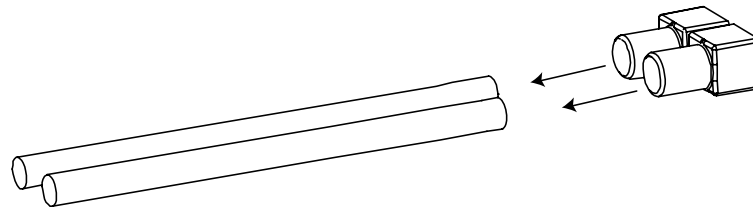

6. Install crimp lugs on the charger end of the DC battery cables using the crimp manufacturer's instructions and tool.

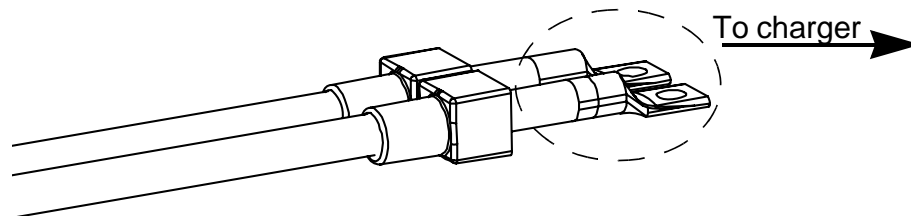

CAUTION: Reverse polarity damage

Before proceeding to the next step, carefully check the wiring polarity – make sure the positive terminals of the Truecharge™ 2 Battery Charger will be connected to the correct terminals of the battery (fuses or breakers) and from there to the positive terminals of the battery. Make sure the negative terminal of the Truecharge™ 2 Battery Charger will be connected to the battery negative terminal (or DC negative bus). Do not reverse the connections.



WARNING: Fire and burn hazard

Make sure that the DC fuse and circuit breaker are open.

7. Connect the negative cable to the negative DC terminal. See Figure 2-1, “Typical Truecharge™ 2 Battery Charger System Installation” on page 2–3.

For one battery or bank

- ◆ Connect the negative cable from the negative terminal on the battery to the negative DC terminal on the Truecharge™ 2 Battery Charger.
Use a flat washer, a lock washer and a nut (five included in the installation kit) to secure the connection.

For more than one battery or bank

- ◆ Connect the negative cable from the negative terminal on the negative ground bar or bus to the negative DC terminal on the Truecharge™ 2 Battery Charger.
Use a flat washer, a lock washer and a nut (five included in the installation kit) to secure the connection.
8. Tighten the nuts to 2.3 N-m (20 lb-in.) torque and test that the wire is secure. Do not over-tighten as this may result in damage to the charger.
 9. Connect each positive cable to the correct positive DC terminal on the Truecharge™ 2 Battery Charger.
Use a flat washer, a lock washer and a nut (5 included in the installation kit) to secure the connection.
 10. Tighten the nuts to 2.3 N-m (20 lb-in.) torque and test that the wire is secure.
 11. Connect the free end of each positive cable assembly to the correct positive terminal of the battery, using sufficient torque as recommended by your battery manufacturer.
 12. Connect the free end of the negative cable to the negative terminal on the battery, using sufficient torque as recommended by your battery manufacturer.
- NOTE:** If you are using more than one battery, you will need to connect the negative cable from each of the batteries to the negative ground bar or bus. The negative ground bar or bus will then have a single negative cable connecting to the negative charger terminal.

13. Secure cables in place using tie-wraps or cable straps according to electrical codes.
14. Slide the rubber boots to cover the DC terminals.

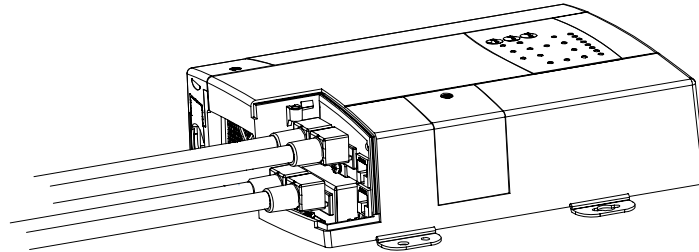

15. If available, route the optional battery temperature sensor (BTS) from the battery (one which is located in the warmest ambient temperature) to the charger location. See “Installing Optional Accessories” on page 2–25.
16. Proceed to “Installing AC Wiring”.

Installing AC Wiring

Before connecting AC wiring, make sure the AC source circuit is protected by a breaker switch of the correct size and type, to comply with the electrical code for your location and application. The current rating of the input breaker should not be larger than 20 A for 120 Vac applications and 16 A for 230 Vac applications, but may be required to be lower depending on the wire size used.



WARNING: Shock hazard

Disconnect the AC source by turning off the breaker feeding the circuit, unplugging from shore power and disconnecting any other power sources (such as a generator).

-
1. Plan the route that the AC supply wiring will follow from the source (usually an AC distribution panel) to the Truecharge™ 2 Battery Charger.
 2. Measure and cut the required length of three-conductor (L, N, GND) cable allowing some extra length for connections and providing some slack.
 3. Route the AC supply wiring from the charger (in its mounted position) to the source.
 4. Unscrew the wiring compartment cover from the left rear of the Truecharge™ 2 Battery Charger to expose the AC wiring access hole and charger's AC pigtail leads.

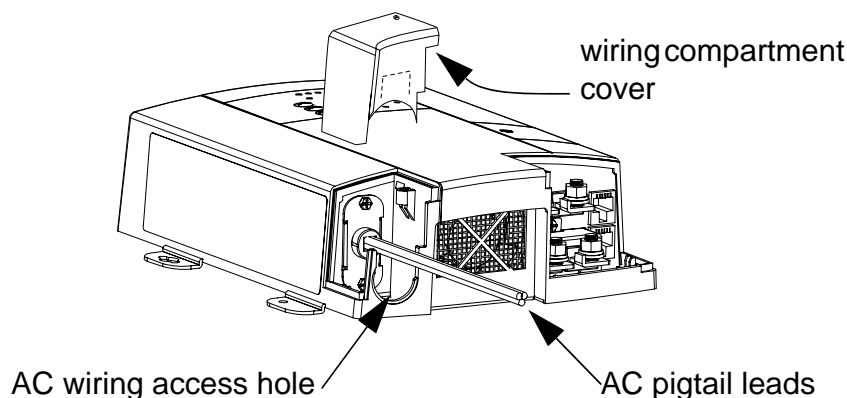

5. Carefully remove 50 – 75 mm (2 – 3 in.) of the outer jacket from the AC supply wiring, being careful not to cut or nick the insulation on the individual conductors.
6. Extend the charger's AC (L, N, GND) pigtail leads (wires) from the AC wiring compartment of the charger.
7. Feed the AC supply wiring through the wider end of strain relief and out the tapered end.

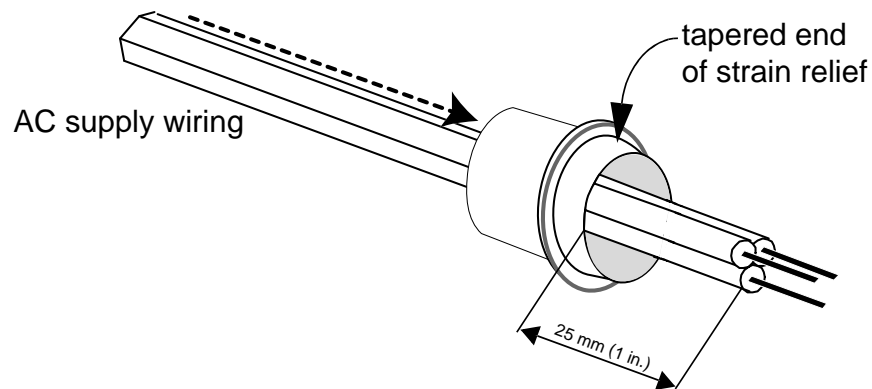

8. Slide the strain relief on the jacket of the wiring (not on the individual conductors) approximately 25 mm (1 in.) from the end of the jacket.
9. Connect the AC supply wires to the Truecharge™ 2 Battery Charger pigtail wires.

NOTE: Connect the line conductor to the AC line, the neutral to the AC neutral, and the ground to the AC ground. The wires are color coded as follows:

Conductor	Charger Pigtail Color Code	AC Supply Wire Color Code
Line	Black	Black (or brown)
Neutral	White	White (or blue)
Ground	Green with yellow stripe	Green with yellow stripe

To connect AC wires with the provided crimp-on butt-splice connector:

- a) Make the connections using the provided crimp-on connectors¹ or with other approved connectors required by your code, and suitable for your installation.

For example, the ABYC Standards and Recommended Practices for Small Craft prohibit twist-on connectors for AC connections on a boat. For other types of installation, refer to your applicable code.



WARNING: Fire hazard

Improper connections may overheat. Exercise care when using any crimp connector, use the tool specified by the crimp connector manufacturer, and follow all instructions.

-
- b) Using a wire stripper, carefully strip 8 mm (5/16 in.) from the ends of the two wires being connected.
 - c) Insert one wire into one end of the butt-splice, until the insulation hits the internal metal crimp section, insert the butt-splice into the crimper², and crimp firmly. The proper location for the crimp is approximately 1.6 mm (1/16 in.) past where the butt-splice insulation tapers down as shown.

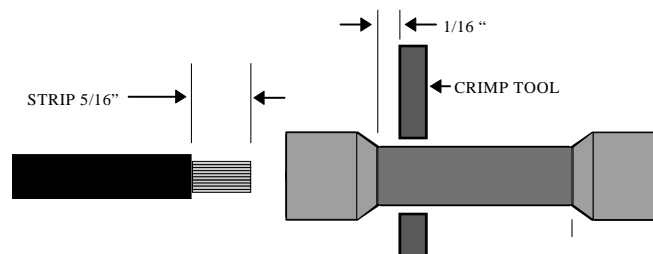

- d) Repeat Step c for the other end of the butt-splice.

1. Provided butt-splice connector (catalog number BNYF2) is available from www.ksterminals.com.

2. Use crimper (product number CT-160) from www.panduit.com.

10. When all connections are completed, push the wiring and connectors inside the AC wiring compartment.
11. Place the strain relief on the AC wiring access hole.
12. Install the wiring compartment cover to fasten the strain relief and tighten the screw on top to secure the cover. Do not over-tighten.

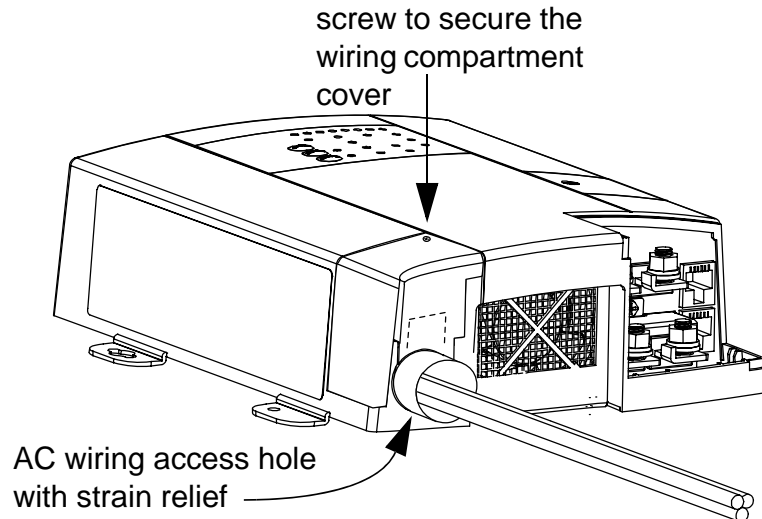

13. Proceed to “Mounting the Optional Remote Panel” on page 2–26, if you have the optional remote panel.
14. Connect the AC supply wiring from the charger to the AC panel feeding the charger.
15. Connect the line conductor to the breaker, the neutral to the neutral bus, and the ground to the ground bus.
16. Secure cables in place using tie-wraps or cable straps according to electrical codes.

Powering Up

Make one last check that all connections are correct and connectors are secure.

The Truecharge™ 2 Battery Charger charger may now be powered up.

1. Close the DC disconnect switch or breaker.



WARNING: Fire hazard

The final connection of the DC battery circuit will generate an arc. Ensure all areas of the system, including batteries and engine compartments, are well ventilated prior to making this connection.

2. Switch the AC power on at the source breaker. It is normal to see a 7 to 10 second delay while the charger powers up. During this time, the indicator LEDs on the onboard display and the remote panel will illuminate for a second (power on test) before reporting charging and battery status information.

Note: The indicator LEDs will also illuminate with DC power alone when DC power is applied and the minimum battery voltage (i.e., the connected batteries) is above 9 V.

Installing Optional Accessories

Optional accessories are available for purchase at Xantrex. Call Customer Service to order the accessories below:

- Battery Temperature Sensor (Part number: 808-0232-01)
- Remote Panel (Part number: 808-8040-00)

Installing the Optional Battery Temperature Sensor (BTS)

Xantrex strongly recommends that you install the optional Battery Temperature Sensor (BTS) to protect your battery and improve charging accuracy. If no BTS is connected, the charger can be set to one of three charging temperature settings (Cold, Warm, or Hot). See “Installing Optional Accessories” on page 2–25 for directions on how to use the charger without a BTS. Regardless of its previous setting, if the BTS connection is lost, the charger will default to Warm in the next charging cycle.

To install a BTS:

Note: If there are multiple batteries, attach the BTS to the battery that is located in the warmest ambient temperature.

1. Switch off all devices operating from the battery.
2. Connect the ring terminal on the sensor directly on to the negative battery stud, or affix the double-sided adhesive backing to the sensor back and attach the sensor to the side of the battery to be monitored.
3. Route the sensor cable to the charger and plug it to the BTS port on the rear panel.

Important: To minimize noise interference, the remote and BTS cables should be routed away from the AC mains line and DC battery cables.

Also, if the BTS is unplugged after a battery over temperature fault, the charger will stop charging. Use the onboard display to set the appropriate temperature setting to restart charging.

Mounting the Optional Remote Panel

To mount the remote panel:

1. Choose a location for the remote panel that is within 15 m (50 ft.) from the charger. Use only the six-conductor communications cable (RJ-12) that came with the remote panel.
2. Use the mounting template provided with the Remote Panel to predrill mounting holes.
Take care that there is nothing behind the surface for you to damage such as other cables or pipes.
3. Connect the RJ-12 connector to the remote panel and route it to the charger. Be careful not to damage the connector locking tab when routing the cable. You can use some tape to protect the locking tab from catching on something and breaking off when routing the cable.
4. Once the Truecharge™ 2 Battery Charger is mounted, plug the other RJ-12 connector into the Remote port on the rear panel of the Truecharge™ 2 Battery Charger.

Note: The RJ-12 communications cable used for the remote panel uses six conductors. The sensor cable for the BTS on the other hand, uses four conductors – an RJ-11 cable.

Configuring the Truecharge™ 2 Battery Charger

Once the charger is connected to a battery on bank 1 or to AC, it is live and it may be configured. The indicator LEDs on the onboard display will illuminate for a second (power on test) before reporting charging and battery status information.

When the remote panel is connected, there will be a short delay of about 15 seconds before reporting charging and battery status information. The remote panel will use this time to query the charger for the current operating conditions.

Configuring the Charger Mode

Using the Onboard Display Panel

To configure the charger mode:

Note: By default, the Charger Mode is set to three-stage.

1. Press and hold the Charger Mode Select button for three seconds to advance to the next setting.
2. Select the proper charger mode.
The LEDs will indicate which of the two modes is being selected: three-stage (default) or two-stage.

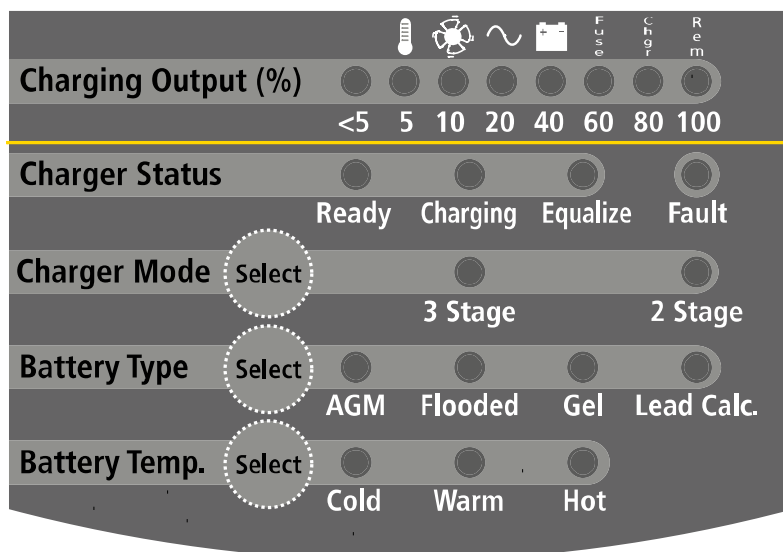

Figure 2-4 Onboard Display Panel

Using the Remote Panel

To configure the charger mode:

Note: By default, the Charger Mode is set to three-stage.

1. Press and hold the Status button for five seconds to enter the Setup mode.
Entering the Setup mode will enable you to select the charger mode.
2. Press ON/STANDBY button to select the desired charger mode.
The LEDs will indicate which of the two types is being selected: three-stage (default) or two-stage.
3. Press and hold the Status button for five seconds to exit the Setup mode.

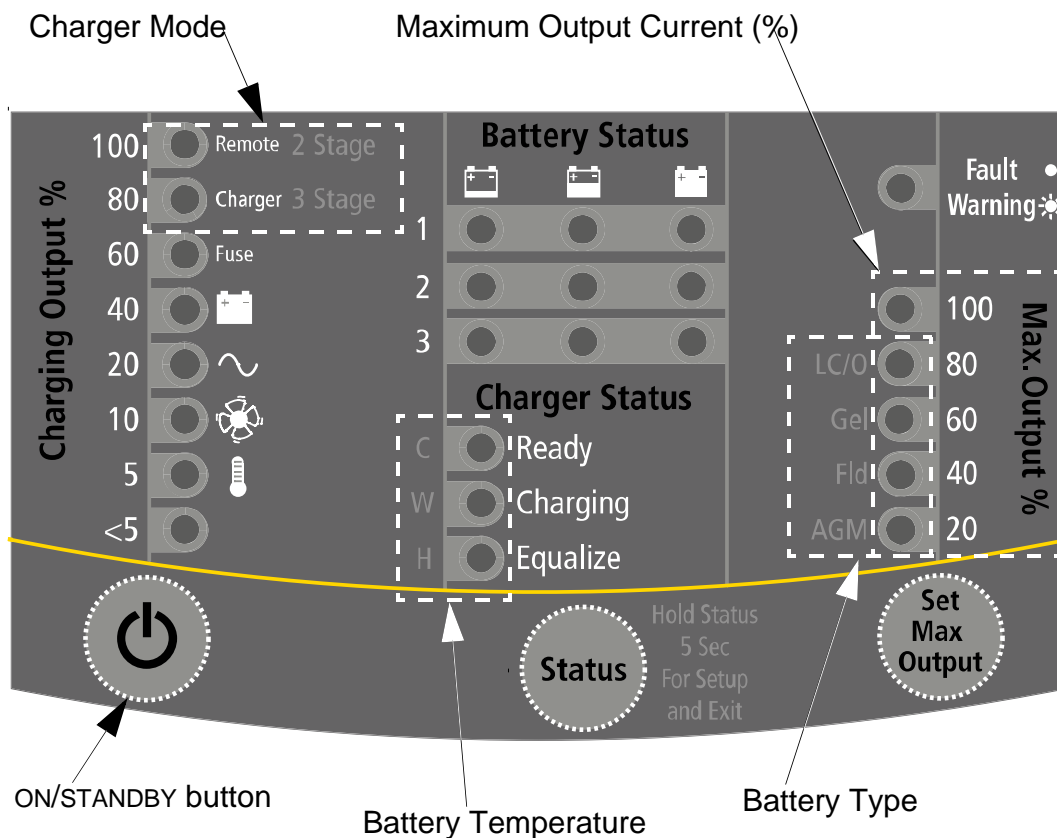

Figure 2-5 Remote Panel

Configuring the Battery Bank Type

Using the Onboard Display Panel

To configure the battery bank type:

Note: By default, the battery type is set to Flooded.

1. Press and hold the Battery Type Select button for three seconds to advance to the next setting.
2. Select the proper battery type.
The LEDs will indicate which of the four types is being selected: Flooded (default), GEL, Lead Calc., AGM.
However, if a custom battery type has been programmed by the OEM, all four LEDs will light up to indicate a fifth type.

Using the Remote Panel

To configure the battery bank type:

Note: By default, the battery type is set to Flooded.

1. Press and hold the Status button for five seconds to enter the Setup mode.
Entering the Setup mode will enable you to select the battery type.
2. Press Set Max Output button to select the proper battery type.
The LEDs will indicate which of the four types is being selected: Flooded (default), GEL, Lead Calc., or AGM.
However, if a custom battery type has been programmed by the OEM, all four LEDs will light up to indicate a fifth type.
3. Press and hold the Status button for five seconds to exit the Setup mode.

Configuring the Maximum Output Current Percentage

Advantages of Current Limiting Feature:

- Gives the user flexibility to custom charge according to the battery manufacturer's instructions.
- Allows batteries with a lower current rating to be charged safely without the need of a new charger.
- Allows drawing less current from an AC source such as a generator which can prevent an overload of the generator.

To configure the maximum output current using the Remote Panel:

NOTE: By default, the Max. Output % is set to 100.

- ◆ Press the Set Max Output button to select the appropriate maximum output setting.

The LEDs will indicate which of the five values is being selected: 100, 80, 60, 40, or 20.

Note: The maximum rated charge current is the only output current rating affected as a result of pressing the Set Max Output button. All other output current ratings, such as the absorption exit current, will not be affected. However, if a setting of 40 or 20 is selected, the equalization charge current will be reduced to a default of 50% capacity.

Installing Batteries

Replacing old or defective batteries (even installing new batteries) requires that you disconnect all AC and DC sources prior to installation.



WARNING

Battery installation should always be treated like a brand new installation. This means, that all safety and precautionary guidelines that were followed prior and during the installation of the charger, must again be followed in order to avoid risks of electrical shock, injury, or death.

To replace an old battery:

1. Turn off the AC source by disconnecting the AC line and/or opening the AC source disconnect.
2. Switch off all devices operating from currently installed batteries.
3. Disconnect the battery cables from the old battery.
NOTE: For Negative chassis systems, disconnect the negative cable first, then the positive cable.
For Positive chassis systems, disconnect the positive cable first, then the negative cable.
Inspect all AC and DC cables for damage and repair, if necessary.
4. Replace the old battery with the new battery.
5. Reconnect the battery cables to the new battery.
NOTE: For Negative chassis systems, reconnect the positive cable first, then the negative cable.
For Positive chassis systems, reconnect the negative cable first, then the positive cable.

Important: If the new battery is different from the old one in chemistry, temperature, or size, remember to re-configure the battery settings accordingly.

A Specifications

Appendix A contains physical, electrical performance, and regulatory approval specifications for the Truecharge™ 2 Battery Charger.

Note: Specifications are subject to change without notice.

This guide for use by qualified installers only

Physical Specifications

Base Unit Dimensions: L × W × H	TC1012, TC1512: 200 × 170 × 70mm (7.87 × 6.70 × 2.76 in.) TC2012, TC3012, TC4012: 250 × 170 × 70mm (9.84 × 6.70 × 2.76 in.) TC5012, TC6012: 350 × 170 × 70mm (13.78 × 6.70 × 2.76 in.) TC1524, TC2024: 250 × 170 × 70mm (9.84 × 6.70 × 2.76 in.) TC3024, TC5024: 300 × 210 × 125mm (11.81 × 8.27 × 4.92 in.)
Weight	TC1012, TC1512: 2.0 kg (4.4 lbs) TC2012, TC3012, TC4012: 2.2 kg (4.8 lbs) TC5012, TC6012: 4.5 kg (9.9 lbs) TC1524, TC2024: 2.2 kg (4.8 lbs) TC3024, TC5024: 5.0 kg (11.0 lbs)
AC input connections	Three color-coded No. 14 AWG wires (L, N, GND) minimum 152 mm (6 in.) long in a separate AC wiring enclosure with 21.3 mm (0.84 in.) hole provision for connection of a ½ inch North American "trade size" strain relief (included).
DC output connections	TC1012: Two M6 studs (1 positive and 1 negative) for battery cable ring terminals and one M6 mm DC equipment ground TC1512: Three M6 studs (2 positives and 1 common negative) for battery cable ring terminals and one M6 mm DC equipment ground TC2012, TC3012, TC4012, TC5012, TC6012, TC1524, TC2024, TC3024, TC5024: Four M6 studs (3 positives and 1 common negative) for battery cable ring terminals and one M6 mm DC equipment ground

Electrical Specifications

AC Input Specifications

AC input voltage range	Nominal: 120 Vac, 230 Vac, 240 Vac Full Performance: 104 – 265 Vac \pm 4 Vac Automatic derating to 80% output: 90 – 108 \pm 4 Vac																								
Maximum AC input current	<table> <tr> <td>at 104 Vac</td> <td>at 230 Vac – 20%</td> </tr> <tr> <td>TC1012: 2.5 A</td> <td>TC1012: 1.25 A</td> </tr> <tr> <td>TC1512: 3.5 A</td> <td>TC1512: 1.9 A</td> </tr> <tr> <td>TC2012: 4.5 A</td> <td>TC2012: 2.5 A</td> </tr> <tr> <td>TC3012: 7.0 A</td> <td>TC3012: 3.7 A</td> </tr> <tr> <td>TC4012: 9.0 A</td> <td>TC4012: 5 A</td> </tr> <tr> <td>TC5012: 11.5 A</td> <td>TC5012: 6.2 A</td> </tr> <tr> <td>TC6012: 13.5 A</td> <td>TC6012: 7.8 A</td> </tr> <tr> <td>TC1524: 7.0 A</td> <td>TC1524: 3.8 A</td> </tr> <tr> <td>TC2024: 9.0 A</td> <td>TC2024: 5 A</td> </tr> <tr> <td>TC3024: 13.5 A</td> <td>TC3024: 7.5 A</td> </tr> <tr> <td>TC5024: 22.5 A</td> <td>TC5024: 12.5 A</td> </tr> </table>	at 104 Vac	at 230 Vac – 20%	TC1012: 2.5 A	TC1012: 1.25 A	TC1512: 3.5 A	TC1512: 1.9 A	TC2012: 4.5 A	TC2012: 2.5 A	TC3012: 7.0 A	TC3012: 3.7 A	TC4012: 9.0 A	TC4012: 5 A	TC5012: 11.5 A	TC5012: 6.2 A	TC6012: 13.5 A	TC6012: 7.8 A	TC1524: 7.0 A	TC1524: 3.8 A	TC2024: 9.0 A	TC2024: 5 A	TC3024: 13.5 A	TC3024: 7.5 A	TC5024: 22.5 A	TC5024: 12.5 A
at 104 Vac	at 230 Vac – 20%																								
TC1012: 2.5 A	TC1012: 1.25 A																								
TC1512: 3.5 A	TC1512: 1.9 A																								
TC2012: 4.5 A	TC2012: 2.5 A																								
TC3012: 7.0 A	TC3012: 3.7 A																								
TC4012: 9.0 A	TC4012: 5 A																								
TC5012: 11.5 A	TC5012: 6.2 A																								
TC6012: 13.5 A	TC6012: 7.8 A																								
TC1524: 7.0 A	TC1524: 3.8 A																								
TC2024: 9.0 A	TC2024: 5 A																								
TC3024: 13.5 A	TC3024: 7.5 A																								
TC5024: 22.5 A	TC5024: 12.5 A																								
Power factor at rated load	\geq 0.95																								
Frequency	47 – 63 Hz																								
Efficiency – peak	12 Vdc units: 77% @ 120 Vac, 80% @ 230 Vac 24 Vdc units: 85% @ 120 Vac, 87% @ 230 Vac																								
Surge protection	Line-to-neutral surge protector rated at 275 Vac																								

DC Output Specifications

Number of isolated battery bank outputs	<p>TC1012: 1 output</p> <p>TC1512: 2 separated outputs</p> <p>TC2012, TC3012, TC4012, TC5012, TC6012, TC1524, TC2024, TC3024, TC5024: 3 separated outputs</p>
DC output voltage range including dead battery charging voltage	<p>12 Vdc units: 0 – 15.5 Vdc</p> <p>24 Vdc units: 0 – 31 Vdc</p>
Maximum equalization voltage	<p>12 Vdc units: 16 Vdc</p> <p>24 Vdc units: 32 Vdc</p>
Voltage accuracy (no load)	<p>12 Vdc units: ±0.1 Vdc at 14.4 Vdc @ 25 °C (77 °F)</p> <p>24 Vdc units: ±0.2 Vdc at 28.8 Vdc @ 25 °C (77 °F)</p>
Nominal battery voltage	<p>12 Vdc units: 12 Vdc</p> <p>24 Vdc units: 24 Vdc</p>
Normal operating output range	<p>12 Vdc units: 0 – 16 Vdc</p> <p>24 Vdc units: 0 – 32 Vdc</p>
Maximum DC output current (total)	<p>TC1012: 10 +10% A</p> <p>TC1512: 15 +10% A</p> <p>TC2012: 20 +10% A</p> <p>TC3012: 30 +10% A</p> <p>TC4012: 40 +10% A</p> <p>TC5012: 50 +10% A</p> <p>TC6012: 60 +10% A</p> <p>TC1524: 15 +10% A</p> <p>TC2024: 20 +10% A</p> <p>TC3024: 30 +10% A</p> <p>TC5024: 50 +10% A</p>

Environmental Specifications

Absorption voltage: ±0.1 V for 12 Vdc units ±0.2 V for 24 Vdc units		12 Vdc units	24 Vdc units
		25 °C (77 °F)	25 °C (77 °F)
	Flooded	14.4	28.8
	GEL	14.2	28.4
	AGM	14.3	28.6
	Lead-calcium	15.5	31.0
Float voltage: ±0.1 V for 12 Vdc units ±0.2 V for 24 Vdc units		12 Vdc units	24 Vdc units
		25 °C (77 °F)	25 °C (77 °F)
	Flooded	13.5	27.0
	GEL	13.8	27.6
	AGM	13.4	26.8
	Lead-calcium	13.5	27.0
Equalize mode current	50% rated output ±6%		
Equalize mode—maximum output voltage	12 V units: 16 ±0.1 Vdc 24 V units: 32 ±0.2 Vdc		
Off-state current draw (without remote installed)	12 V units: <35 mA dc 24 V units: <20 mA dc		
Voltage regulation	Uncompensated load voltage regulation < 0.1Vdc drop from 0 Amps to rated current output at charger output terminals (adds in series with recommended 3% limit for user's battery cable voltage drop).		

Environmental Specifications

Operating range (full performance)	0 – 50 °C (32 – 122 °F)
Current de-rating (above 50 °C ambient temperature)	up to 80% derating I _{max} 50 – 65 °C (122 – 149 °F)
Storage	–40 to 80 °C (–40 to 176 °F)
Humidity	5 – 95%, RH non-condensing

Protection Features

Battery reverse polarity	Protected by replaceable DC output fuses
Over-voltage limits	The Truecharge™ 2 Battery Charger will stop charging if the output voltage is above 16.6 ± 0.5 Vdc.
Output current limit	TC1012: 10 +10% A TC1512: 15 +10% A TC2012: 20 +10% A TC3012: 30 +10% A TC4012: 40 +10% A TC5012: 50 +10% A TC6012: 60 +10% A TC1524: 15 +10% A TC2024: 20 +10% A TC3024: 30 +10% A TC5024: 50 +10% A
Over-temperature	Internal charger temperature is measured. Charger shuts down and restarts as follows: <ul style="list-style-type: none"> • Shutdown at 70 °C (158 °F) • Restart at 60 °C (140 °F)
Current derating in ambient temperatures	See “Environmental Specifications” on page A-5.
Battery over-temperature protection	Charger shuts down if battery temperature above 70 °C (158 °F) is sensed by the battery temperature sensor.
Battery under-temperature protection	Charger shuts down if battery temperature below -25 °C (-13 °F) is sensed by the battery temperature sensor.

Approvals

Safety	<p>NRTL approved to CSA E60335-2-29, UL1236, including the marine supplement, ignition protection, and UL1564</p> <p>CE marked for the Low Voltage Directive 2006-95-EC, (complying with EN60335-2-29 Battery Chargers)</p> <p>Designed to IEC60335-2-29 including Australian deviations, ISO 8846: Ignition Protection for Small Craft, ABYC E11 - Alternating Current and Direct Current Electrical Systems on Boats, and ABYC A31 - Battery Chargers and Inverters</p>
EMC	<p>Class B according to FCC Part 15B and Industry Canada ICES-003</p> <p>CE marked for the EMC Directive 2004-108-EC (complying with EN55014-1, EN55014-2, EN61000-3-2, and EN61000-3-3)</p>

Xantrex Technology Inc.

1 800 670 0707 Tel toll free NA

1 408 987 6030 Tel direct

+34 93 470 5330 Europe

1 800 994 7828 Fax toll free NA

+34 93 473 6093 Europe

customerservice@xantrex.com

www.xantrex.com

975-0402-01-01

Printed in China