

## AVR-P28B PROTOTYPE BOARD WITH 10 PIN ICSP CONNECTOR FOR 28 PIN AVR MICROCONTROLLERS

### **Features:**

AVR-P28B is prototype board for 28 pin AVR microcontrollers with following features:

- RS232 Tx, Rx interface with MAX232 IC
- ICSP 10 pin connector (STK compatible)
- RESET IC ZM33064C
- Status LED connected to PC5 via removable jumper
- 4MHz or 8MHz quartz oscillator
- extension slot on each microcontroller pin
- DIL28 microcontroller socket
- AGND-GND and AVCC-VCC jumpers
- power supply plug in jack connector
- +5V power supply voltage regulator
- 0.1" (2.54 mm) grid
- dimensions: 100x80 mm
- four mounting holes

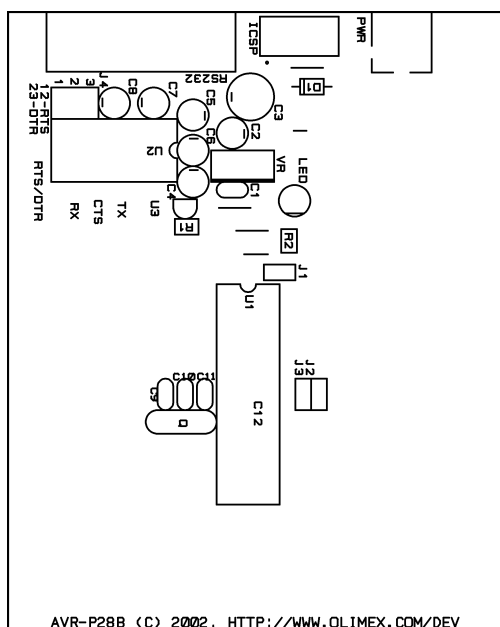

### **Programming:**

To program AVR-P28B you need serial port or parallel port AVR-ICSP programmer dongle (Olimex part # AVR-PG1B or AVR-PG2B).

The serial port ICSP programmer (AVR-PG1B) works with PonyProg software by from Claudio Lanconelli and the latest release may be download for free from <http://www.lancos.com>

The parallel port ICSP programmer (AVR-PG2B) works with AVR ISP from Atmel and may be download for free from Atmel's web site.

### **ICSP interface:**

The ICSP connector is 2x5 pin with 0,1" step and Atmel STKxxx compatible layout. The PIN.1 is marked with square pad on bottom and arrow on top. ICSP signals are: 1- MOSI, 2- VCC, 3- NC, 4- GND, 5- RST, 6- GND, 7- SCK, 8- GND, 9- MISO, 10- GND

TOP view PCB board layout:

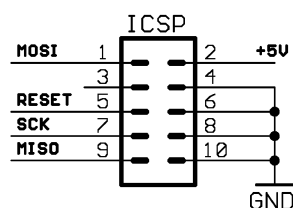

### **RS232 interface:**

J4 removable jumper selects where RTS/DTR line to be connected. In position 12 the line is connected to RTS, in position 23 is connected to DTR.

### **Status LED:**

Connected to PC5 via removable jumper J1.

### **Oscillator circuit:**

Crystal resonator connected to XTAL1 and XTAL2.

### **RESET supervisor circuit:**

IC ZM33064C with 4.6V threshold.

### **Analog Vcc and GND:**

J2 connects AVCC to VCC.

J3 connects AGND to GND.

### **Supported devices:**

AT90S2333, AT90LS2333, AT90S4433,  
AT90LS4433, ATtiny28L, ATtiny28V  
microcontrollers.

### **Ordering codes:**

AVR-P28B-4MHz - assembled and tested  
AVR-P28B-8MHz - assembled and tested  
AVR-P28B/PCB - only PCB

Copyright(c) 2002, OLIMEX Ltd, All right reserved.

Development boards for PIC, AVR and MSP430 microcontrollers <http://www.olimex.com/dev>

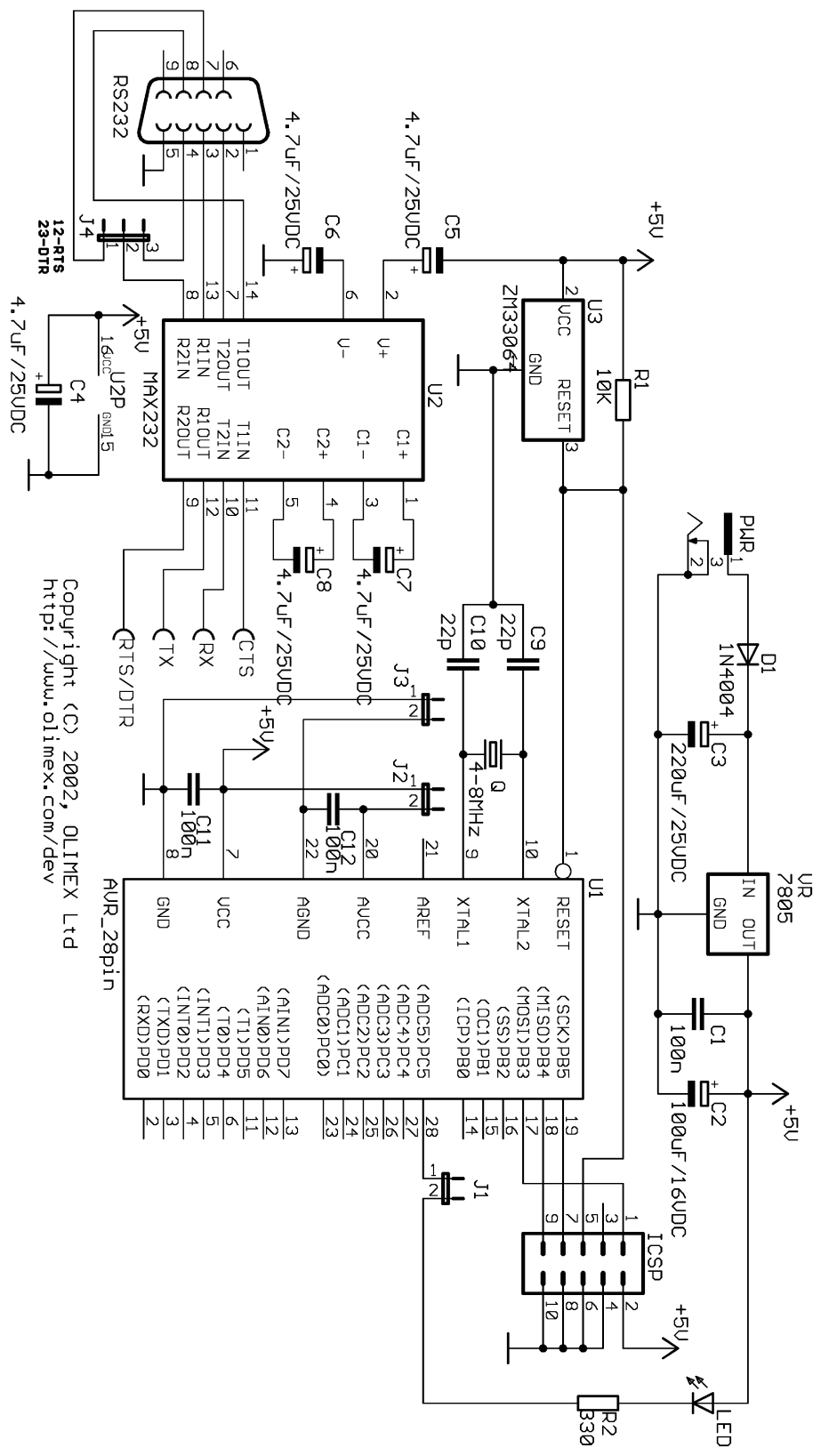

Copyright (C) 2002, OLIMEX Ltd  
<http://www.olimex.com/dev>