



Features

- Lead free as standard
- RoHS compliant*
- Protects 1 or 2 lines
- Unidirectional & bidirectional configurations
- ESD protection > 40 KV

Applications

- RS-232, RS-422 & RS-423 data lines
- Portable electronics
- Wireless bus protection
- Control & monitoring systems

CDSOT23-T03~T36C – TVS Diode Array Series

General Information

The markets of portable communications, computing and video equipment are challenging the semiconductor industry to develop increasingly smaller electronic components.

Bourns offers Transient Voltage Suppressor Array diodes for surge and ESD protection applications, in compact chip package SOT23 size format. The Transient Voltage Suppressor Array series offers a choice of voltage types ranging from 3 V to 36 V. Bourns® Chip Diodes conform to JEDEC standards, are easy to handle on standard pick and place equipment and their flat configuration minimizes roll away.

The Bourns device will meet IEC 61000-4-2 (ESD), IEC 61000-4-4 (EFT) and IEC 61000-4-5 (Surge) requirements.

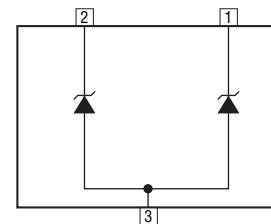
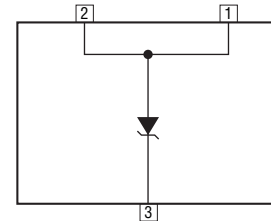

Thermal Characteristics (@ T_A = 25 °C Unless Otherwise Noted)

Parameter	Symbol	Value	Unit
Operating Temperature	T _J	-55 to +150	°C
Storage Temperature	T _{STG}	-55 to +150	°C

Electrical Characteristics (@ T_A = 25 °C Unless Otherwise Noted)

Parameter	Symbol	CDSOT23-														Unit
		Uni-	Bi-	Uni-	Bi-	Uni-	Bi-	Uni-	Bi-	Uni-	Bi-	Uni-	Bi-	Uni-	Bi-	
		T03	T03C	T05	T05C	T08	T08C	T12	T12C	T15	T15C	T24	T24C	T36	T36C	
Breakdown Voltage @ 1 mA	V _{BR}	4.0		6.0		8.5		13.3		16.7		26.7		40.0		V
Working Peak Voltage	V _{WM}	3.3		5.0		8.0		12.0		15.0		24.0		36.0		V
Maximum Clamping Voltage V _C @ I _P = 1 A ¹	V _F	7.0		9.8		13.4		19.0		24.0		43.0		51.0		V
Maximum Clamping Voltage @ 8/20 μs V _C @ I _{PP} ¹	V _F	10.9 V @ 43 A		13.5 V @ 42 A		16.9 V @ 34 A		25.9 V @ 21 A		30.0 V @ 17 A		49.0 V @ 12 A		76.8 V @ 9 A		V
Maximum Leakage Current @ V _{WM}	I _D	125		20		10		2		1		1		1		μA
Typical Cap Unidirectional @ 0 V, 1 MHz	C _{j(SD)}	500		350		250		150		100		88		80		pF
Typical Cap Bidirectional @ 0 V, 1 MHz	C _{j(SD)}	300		210		150		90		60		63		60		pF
Peak Pulse Power (t _p = 8/20 μs) ²	P _{PP}	500														W
Forward Voltage @ 100 mA, 300 μs – Square Wave ³	V _F	1.5														V

Notes:

1. See Pulse Wave Form.
2. See Peak Pulse Power vs. Pulse Time.
3. Only applies to unidirectional devices.
4. Part numbers with a "C" suffix are bidirectional devices, i.e., CDSOT23-T03C.

*RoHS Directive 2002/95/EC Jan 27 2003 including Annex
Specifications are subject to change without notice.
Customers should verify actual device performance in their specific applications.

CDSOT23-T03~T36C – TVS Diode Array Series



Product Dimensions

This is a molded JEDEC SOT-23 package with lead free 100 % Sn plating on the lead frame. It weighs approximately 0.6 g and has a flammability rating of UL 94V-0.

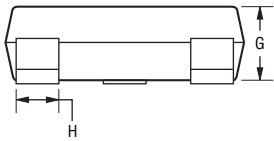
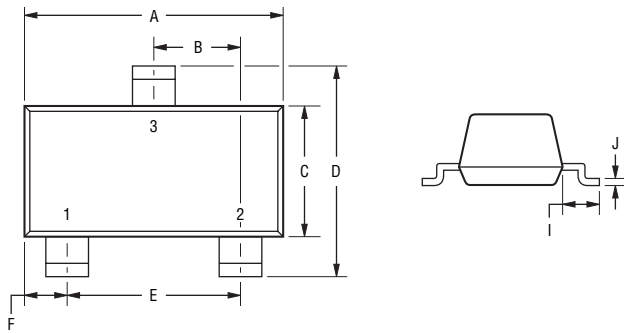

DIMENSIONS = $\frac{\text{MILLIMETERS}}{\text{(INCHES)}}$

Dimensions	
A	$\frac{2.80 - 3.04}{(0.1102 - 0.1197)}$
B	$\frac{0.89 - 1.02}{(0.0350 - 0.0401)}$
C	$\frac{1.20 - 1.40}{(0.0472 - 0.0551)}$
D	$\frac{2.10 - 2.50}{(0.0830 - 0.0984)}$
E	$\frac{1.78 - 2.04}{(0.0701 - 0.0807)}$
F	$\frac{0.45 - 0.60}{(0.0177 - 0.0236)}$
G	$\frac{0.89 - 1.11}{(0.035 - 0.044)}$
H	$\frac{0.34 - 0.50}{(0.0150 - 0.0200)}$
I	$\frac{0.45 - 0.60}{(0.0180 - 0.0236)}$
J	$\frac{0.085 - 0.177}{(0.0034 - 0.0070)}$

Recommended Footprint

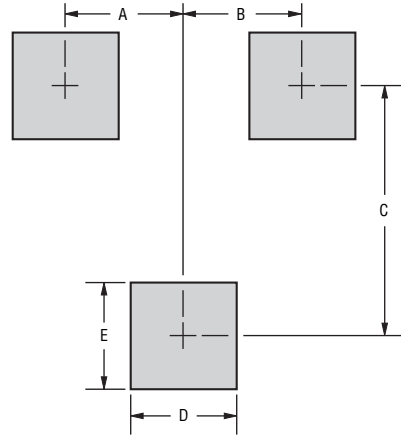

DIMENSIONS = $\frac{\text{MILLIMETERS}}{\text{(INCHES)}}$

Dimensions	
A	$\frac{0.95}{(0.037)}$
B	$\frac{0.95}{(0.037)}$
C	$\frac{2.00}{(0.079)}$
D	$\frac{0.85}{(0.033)}$
E	$\frac{0.85}{(0.033)}$

How To Order

Common Code _____ **CD S0T23 - T 03 C**
 Chip Diode
 Package _____
 • S0T23 = S0T23 Package
 Model _____
 T = Transient Voltage Suppressor
 Working Peak Voltage _____
 3 = 3 V_{RWM} (Volts)
 Suffix _____
 C = Bidirectional Diode

Specifications are subject to change without notice. Customers should verify actual device performance in their specific applications.

Performance Graphs

Peak Pulse Power vs Pulse Time

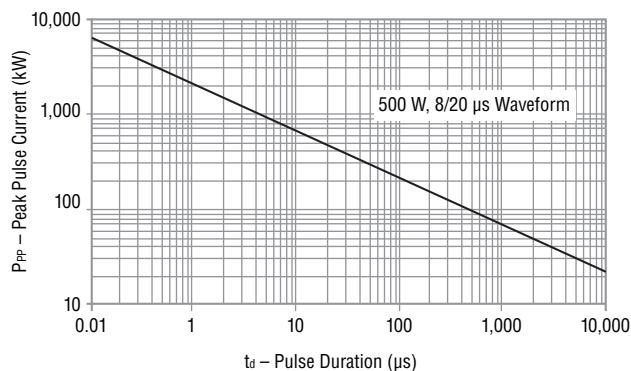

Pulse Wave Form

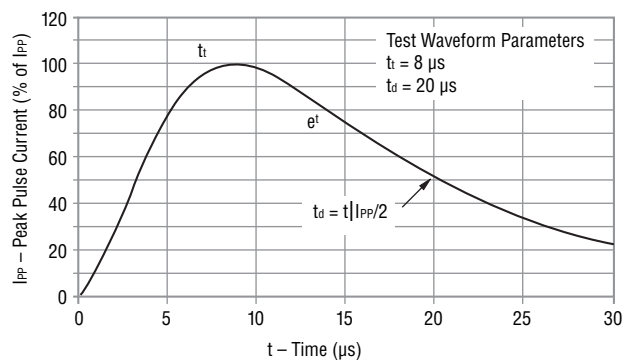

Block Diagram

The device block diagrams below include the pin names and basic electrical connections associated with each channel.

Unidirectional

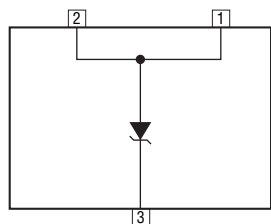

Bidirectional

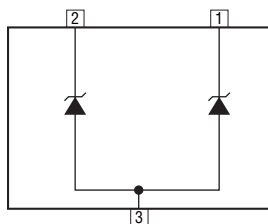

Power Derating Curve

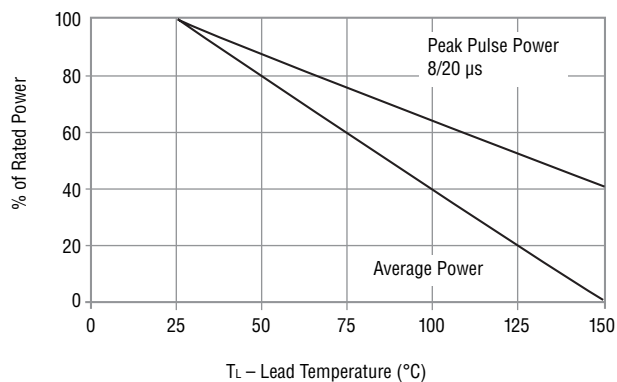

CDSOT23-T03~T36C – TVS Diode Array Series

BOURNS®

Packaging

The surface mount product is packaged in a 12 mm x 8 mm Tape and Reel format per EIA-481 standard.

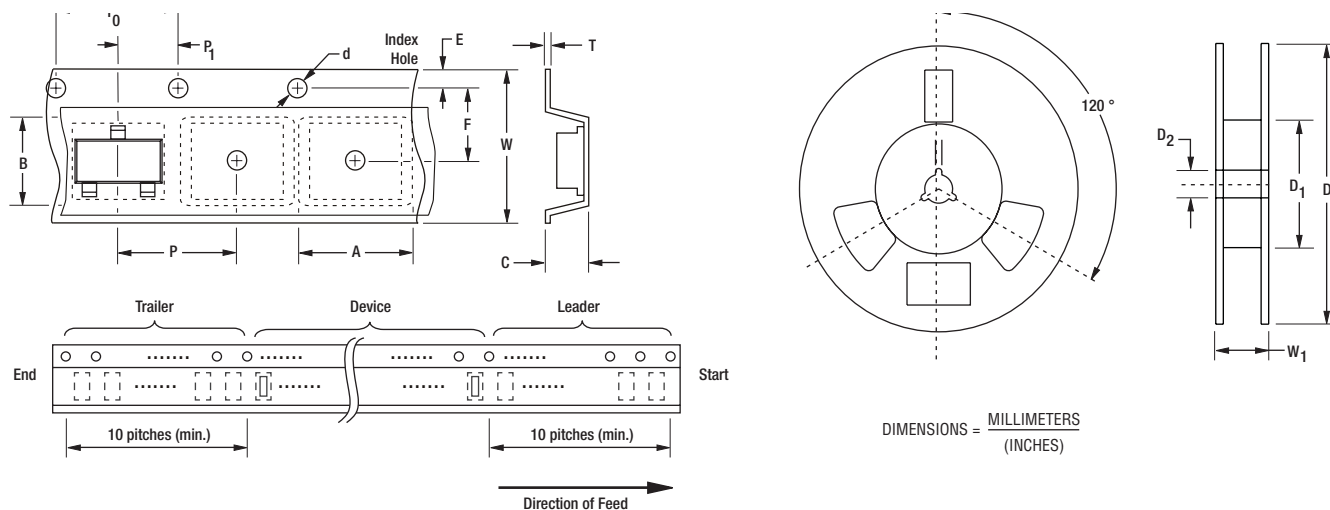

Item	Symbol	SOT23
Carrier Width	A	$\frac{2.25 \pm 0.10}{(0.088 - 0.004)}$
Carrier Length	B	$\frac{2.34 \pm 0.10}{(0.092 - 0.004)}$
Carrier Depth	C	$\frac{1.22 \pm 0.10}{(0.048 - 0.004)}$
Sprocket Hole	d	$\frac{1.55 \pm 0.05}{(0.061 - 0.002)}$
Reel Outside Diameter	D	$\frac{178}{(7.008)}$
Reel Inner Diameter	D ₁	$\frac{50.0}{(1.969)}$ Min.
Feed Hole Diameter	D ₂	$\frac{13.0 \pm 0.20}{(0.512 - 0.008)}$
Sprocket Hole Position	E	$\frac{1.75 \pm 0.10}{(0.069 - 0.004)}$
Punch Hole Position	F	$\frac{3.50 \pm 0.05}{(0.138 - 0.002)}$
Punch Hole Pitch	P	$\frac{4.00 \pm 0.10}{(0.157 - 0.004)}$
Sprocket Hole Pitch	P ₀	$\frac{4.00 \pm 0.10}{(0.157 - 0.004)}$
Embossment Center	P ₁	$\frac{2.00 \pm 0.05}{(0.079 - 0.002)}$
Overall Tape Thickness	T	$\frac{0.20 \pm 0.10}{(0.008 - 0.004)}$
Tape Width	W	$\frac{8.00 \pm 0.20}{(0.315 - 0.008)}$
Reel Width	W ₁	$\frac{14.4}{(0.567)}$ Max.
Quantity per Reel	—	3,000



Asia-Pacific:

Tel: +886-2 2562-4117 • Fax: +886-2 2562-4116

Europe:

Tel: +41-41 768 5555 • Fax: +41-41 768 5510

The Americas:

Tel: +1-951 781-5500 • Fax: +1-951 781-5700

www.bourns.com

REV. 08/10

Specifications are subject to change without notice. Customers should verify actual device performance in their specific applications.