

| Product Description: P420HW02 V0 TFT-LCD PANEL |                                     |     |      |
|--|-------------------------------------|-----|------|
|  |                                     |     |      |
| AUO Model Name: P420HW02 V0                    |                                     |     |      |
| Customer Part No/Project Name:                 |                                     |     |      |
| Customer Signature                             | Date                                | AUO | Date |
|  | Reviewed by : PM Head / Louis Cheng |     |      |
|  | -----                               |     |      |
|  | Reviewed by : RD Head / Kelvin Chou |     |      |
|  | -----                               |     |      |
| Reviewed by : Project Leader / Steven Kuo      |                                     |     |      |
| -----  |                                     |     |      |
| Prepared By : PM / Eddie Peng                  |                                     |     |      |
| -----  |                                     |     |      |

*Document Version: 0.1*

*Date:2009/7/17*

## **Product Functional Specification**

**42" Full-HD Color TFT-LCD Module**  
**Model Name: P420HW02 V0**

**(\*) Preliminary Specification**  
**( ) Final Specification**

Note : This specification is subject to change without notice.

## Contents

| No  | ITEM                         |
|-----|------------------------------|
|     | COVER                        |
|     | CONTENTS                     |
|     | RECORD OF REVISIONS          |
| 1   | GENERAL DESCRIPTION          |
| 2   | ABSOLUTE MAXIMUM RATINGS     |
| 3   | ELECTRICAL SPECIFICATIONS    |
| 3-1 | ELECTRICAL CHARACTERISTICS   |
| 3-2 | INTERFACE CONNECTIONS        |
| 3-3 | SIGNAL TIMING SPECIFICATIONS |
| 3-4 | SIGNAL TIMING WAVEFORMS      |
| 3-5 | COLOR INPUT DATA REFERENCE   |
| 3-6 | POWER SEQUENCE               |
| 4   | OPTICAL SPECIFICATIONS       |
| 5   | MECHANICAL CHARACTERISTICS   |
| 6   | RELIABILITY                  |
| 7   | INTERNATIONAL STANDARDS      |
| 7-1 | SAFETY                       |
| 7-2 | EMC                          |
| 8   | PACKING                      |
| 9   | PRECAUTIONS                  |

### Record of Revision

| Version | Date      | Page | Old Description                | New Description | Remark |
|---------|-----------|------|--------------------------------|-----------------|--------|
| 0.1     | 2009/7/17 |      | Preliminary spec first release |                 |        |
|         |           |      |                                |                 |        |
|         |           |      |                                |                 |        |
|         |           |      |                                |                 |        |
|         |           |      |                                |                 |        |
|         |           |      |                                |                 |        |
|         |           |      |                                |                 |        |
|         |           |      |                                |                 |        |
|         |           |      |                                |                 |        |
|         |           |      |                                |                 |        |
|         |           |      |                                |                 |        |
|         |           |      |                                |                 |        |
|         |           |      |                                |                 |        |
|         |           |      |                                |                 |        |
|         |           |      |                                |                 |        |
|         |           |      |                                |                 |        |
|         |           |      |                                |                 |        |
|         |           |      |                                |                 |        |
|         |           |      |                                |                 |        |
|         |           |      |                                |                 |        |
|         |           |      |                                |                 |        |
|         |           |      |                                |                 |        |
|         |           |      |                                |                 |        |
|         |           |      |                                |                 |        |
|         |           |      |                                |                 |        |
|         |           |      |                                |                 |        |
|         |           |      |                                |                 |        |
|         |           |      |                                |                 |        |

# 1. General Description

This specification applies to the 42 inch Color TFT-LCD Module P420HW02 V0. This LCD module has a TFT active matrix type liquid crystal panel 1920x1080 pixels, and diagonal size of 42 inch. This module supports 1920x1080 Full-HD mode (Non-interlace).

Each pixel is divided into Red, Green and Blue sub-pixels or dots which are arranged in vertical stripes. Gray scale or the brightness of the sub-pixel color is determined with a 8-bit gray scale signal for each dot.

The P420HW02 V0 has been designed to apply the 8/10-bit selectable 2 channel LVDS interface method. It is intended to support displays where narrow bezel width, high brightness, wide viewing angle, high color saturation, and high color depth.

## \* General Information

| Items               | Specification                                      | Unit   | Note          |
|---------------------|--|--------|---------------|
| Active Screen Size  | 42.02  | inches |               |
| Display Area        | 930.24(H) x 523.26(V)                              | mm     |               |
| Outline Dimension   | 957.45(H) x 550.2(V) x 52.7(D)                     | mm     | With inverter |
| Driver Element      | a-Si TFT active matrix                             |        |               |
| Display Colors      | 1073 M   | Colors |               |
| Number of Pixels    | 1920 x 1080  | Pixel  |               |
| Pixel Pitch         | 0.4845   | mm     |               |
| Pixel Arrangement   | RGB vertical stripe                                |        |               |
| Display Mode        | Normally Black                                     |        |               |
| Lamp quantity, type | 16pcs, Straight type                               | pcs    |               |
| Surface Treatment   | Anti-Glare coating (Haze 11%)<br>Hard coating (3H) |        |               |
| Display Orientation | Portrait/Landscape enable                          |        |               |
| Front Chassis Color | Black  |        |               |

## 2. Absolute Maximum Ratings

The following are maximum values which, if exceeded, may cause faulty operation or damage to the unit.

| Item                           | Symbol           | Min  | Max  | Unit   | Note |
|--------------------------------|------------------|------|------|--------|------|
| Power Supply Input Voltage     | V <sub>DD</sub>  | -0.3 | 14   | [Volt] | 1    |
| Logic Input Voltage            | V <sub>in</sub>  | -0.3 | 3.6  | [Volt] | 1    |
| BLU Input Voltage              | V <sub>DDB</sub> | -0.3 | 26.4 | [Volt] | 1    |
| BLU Brightness Control Voltage | BL <sub>ON</sub> | -0.3 | 3.6  | [Volt] | 1    |
| Ambient Operating Temperature  | T <sub>OP</sub>  | 0    | +50  | [°C]   | 2    |
| Ambient Operating Humidity     | H <sub>OP</sub>  | 10   | 80   | [%RH]  | 2    |
| Storage Temperature            | T <sub>ST</sub>  | -10  | +60  | [°C]   | 2    |
| Storage Humidity               | H <sub>ST</sub>  | 10   | 80   | [%RH]  | 2    |
| Shock (non-operation)          |                  | -    | 40   | G      | 3    |
| Vibration (non-operation)      |                  | -    | 1.5  | G      | 4    |
| Thermal shock                  |                  | -20  | 60   | C      | 5    |

Note 1 : Duration = 50msec

Note 2 : Maximum Wet-Bulb should be 39°C and No condensation.

Note 3 : Half sine wave, shock level : 40G(11ms), direction : ±x, ±y, ±z (one time each direction)

Note 4 : Wave form : Random, vibration level : 1.5G RMS, Bandwidth : 10~500Hz  
Duration : X,Y,Z 30min (one time each direction)

Note 5 : -20C/1hr ~ 60C/1hr, 100 cycles

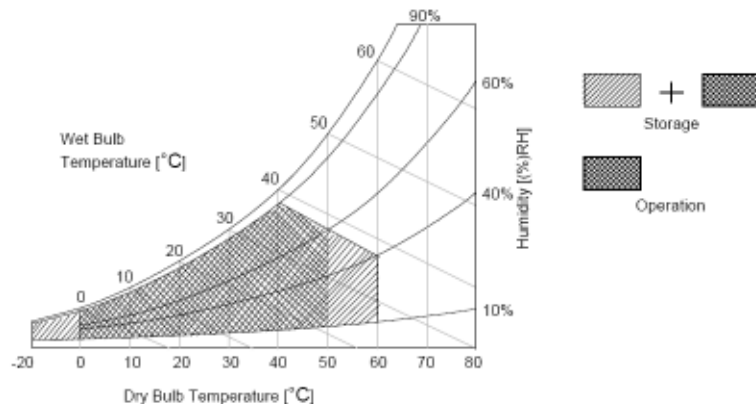

### 3. Electrical Specification

The P420HW02 requires two power inputs. One is employed to power the LCD electronics and to drive the TFT array and liquid crystal. The second input, which powers the CCFL, is typically generated by an inverter.

#### 3-1 Electrical Characteristics

| Parameter                   |   | Symbol                 | Values |        |      | Unit  | Notes |
|-----------------------------|---|------------------------|--------|--------|------|-------|-------|
|                             |   |                        | Min    | Typ    | Max  |       |       |
| LCD:                        |   |                        |        |        |      |       |       |
| Power Supply Input Voltage  |   | Vdd                    | 10.8   | 12     | 13.2 | Vdc   |       |
| Power Supply Input Current  |   | Idd                    | -      | 0.8    |      | A     | 1     |
| Power Consumption           |   | Pc                     | -      | 9.6    |      | Watt  | 1     |
| Inrush Current              |   | I <sub>RUSH</sub>      | -      | -      | 4    | A     | 5     |
| LVDS Interface              | Differential Input High Threshold Voltage | V <sub>TH</sub>        |        |        | +100 | mV    | 4     |
|                             | Differential Input Low Threshold Voltage  | V <sub>TL</sub>        | -100   |        |      | mV    | 4     |
|                             | Common Input Voltage                      | V <sub>CIM</sub>       | 0.6    | 1.2    | 1.8  | V     |       |
| CMOS Interface              | Input High Threshold Voltage              | V <sub>IH</sub> (High) | 2.0    |        | 3.3  | Vdc   |       |
|                             | Input Low Threshold Voltage               | V <sub>IL</sub> (Low)  | 0      |        | 0.8  | Vdc   |       |
| Backlight Power Consumption |   |                        |        | 175    |      | Watt  | 2     |
| Life Time                   |   |                        | 50,000 | 60,000 |      | Hours | 3     |

The performance of the Lamp in LCM, for example life time or brightness, is extremely influenced by the characteristics of the DC-AC Inverter. So all the parameters of an inverter should be carefully designed so as not to produce too much leakage current from high-voltage output of the inverter. When you design or order the inverter, please make sure unwanted lighting caused by the mismatch of the lamp and the inverter (no lighting, flicker, etc) never occurs. When you confirm it, the LCD Assembly should be operated in the same condition as installed in your instrument.

Do not attach a conducting tape to lamp connecting wire. If the lamp wire attach to conducting tape, TFT-LCD Module have a low luminance and the inverter has abnormal action because leakage current occurs between lamp wire and conducting tape.

The relative humidity must not exceed 80% non-condensing at temperatures of 40°C or less. At temperatures greater than 40°C, the wet bulb temperature must not exceed 39°C. When operate at low temperatures, the brightness of CCFL will drop and the lifetime of CCFL will be reduced.

**Note :**

1. V<sub>dd</sub>=12.0V, f<sub>v</sub>=60Hz, f<sub>CLK</sub>=80 Mhz , 25°C, V<sub>dd</sub> Duration time= 470 μs , Test pattern : white pattern
2. The Backlight power consumption shown above does include loss of external inverter at 25°C. The used lamp current is the lamp typical current
3. The life is determined as the time at which luminance of the lamp is 50% compared to that of initial value at the typical lamp current on condition of horizontally continuous operating at 25±2°C.
4. V<sub>CIM</sub> = 1.2V

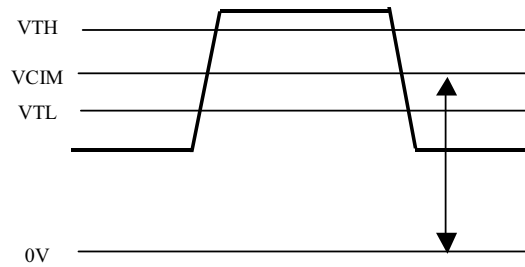

**Figure : LVDS Differential Voltage**

5. Measurement Condition: Rising time = 470 μs

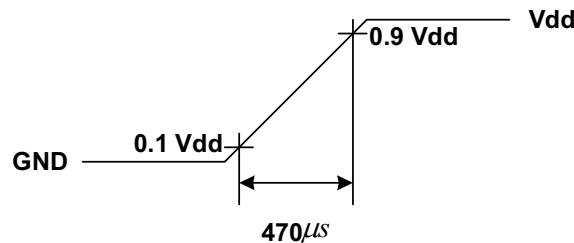



### 3-2 Interface Connections

- LCD connector: P-TWO 187059-5122 which is compatible FI-RE51S-HF (JAE)

| No | Symbol   | Description                                 | No | Symbol  | Description  |
|----|----------|---|----|---------|--|
| 1  | GND      | Ground                                      | 27 | BIT_SEL | 8/10 bit LVDS :(NC/Low:10 bits selection High : 8 bits ) |
| 2  | NC       | No connection                               | 28 | RE_0N   | SECOND CHANNEL 0-  |
| 3  | NC       | No connection                               | 29 | RE_0P   | SECOND CHANNEL 0+  |
| 4  | NC       | No connection                               | 30 | RE_1N   | SECOND CHANNEL 1-  |
| 5  | NC       | No connection                               | 31 | RE_1P   | SECOND CHANNEL 1+  |
| 6  | Reserved | AUO Internal test (open or low)             | 32 | RE_2N   | SECOND CHANNEL 2-  |
| 7  | LVDS SEL | LVDS order(NC/Low:NS mode High: JEIDA mode) | 33 | RE_2P   | SECOND CHANNEL 2+  |
| 8  | NC       | No connection                               | 34 | GND     | Ground   |
| 9  | Reserved | Open or high                                | 35 | RE_CLKN | SECOND CLOCK CHANNEL C-                                  |
| 10 | Reserved | Open or high                                | 36 | RE_CLKP | SECOND CLOCK CHANNEL C+                                  |
| 11 | GND      | Ground                                      | 37 | GND     | Ground   |
| 12 | RO_0N    | FIRST CHANNEL 0-                            | 38 | RE_3N   | SECOND CHANNEL 3-  |
| 13 | RO_0P    | FIRST CHANNEL 0+                            | 39 | RE_3P   | SECOND CHANNEL 3+  |
| 14 | RO_1N    | FIRST CHANNEL 1-                            | 40 | RE_4N   | SECOND CHANNEL 4-  |
| 15 | RO_1P    | FIRST CHANNEL 1+                            | 41 | RE_4P   | SECOND CHANNEL 4+  |
| 16 | RO_2N    | FIRST CHANNEL 2-                            | 42 | GND     | Ground   |
| 17 | RO_2P    | FIRST CHANNEL 2+                            | 43 | GND     | Ground   |
| 18 | GND      | Ground                                      | 44 | GND     | Ground   |
| 19 | RO_CLKN  | FIRST CLOCK CHANNEL C-                      | 45 | GND     | Ground   |
| 20 | RO_CLKP  | FIRST CLOCK CHANNEL C+                      | 46 | GND     | Ground   |
| 21 | GND      | Ground                                      | 47 | NC      | No connection  |
| 22 | RO_3N    | FIRST CHANNEL 3-                            | 48 | VLCD    | Power Supply +12V  |
| 23 | RO_3P    | FIRST CHANNEL 3+                            | 49 | VLCD    | Power Supply +12V  |
| 24 | RO_4N    | FIRST CHANNEL 4-                            | 50 | VLCD    | Power Supply +12V  |
| 25 | RO_4P    | FIRST CHANNEL 4+                            | 51 | VLCD    | Power Supply +12V  |
| 26 | GND      | Ground                                      | -  | -       | -  |

Note: 1. All GND (ground) pin should be connected together to the LCD module's metal frame.

2. All  $V_{LCD}$  ( power input ) pins should be connected.

**LVDS Option = High → JEIDA**

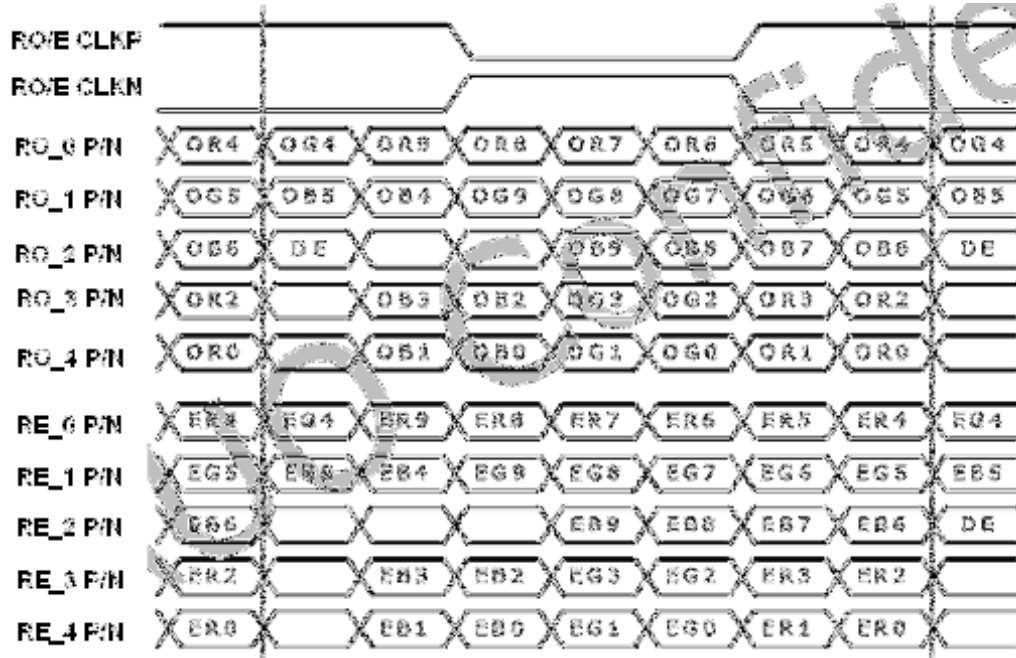

**LVDS Option = Low/Open → NS**

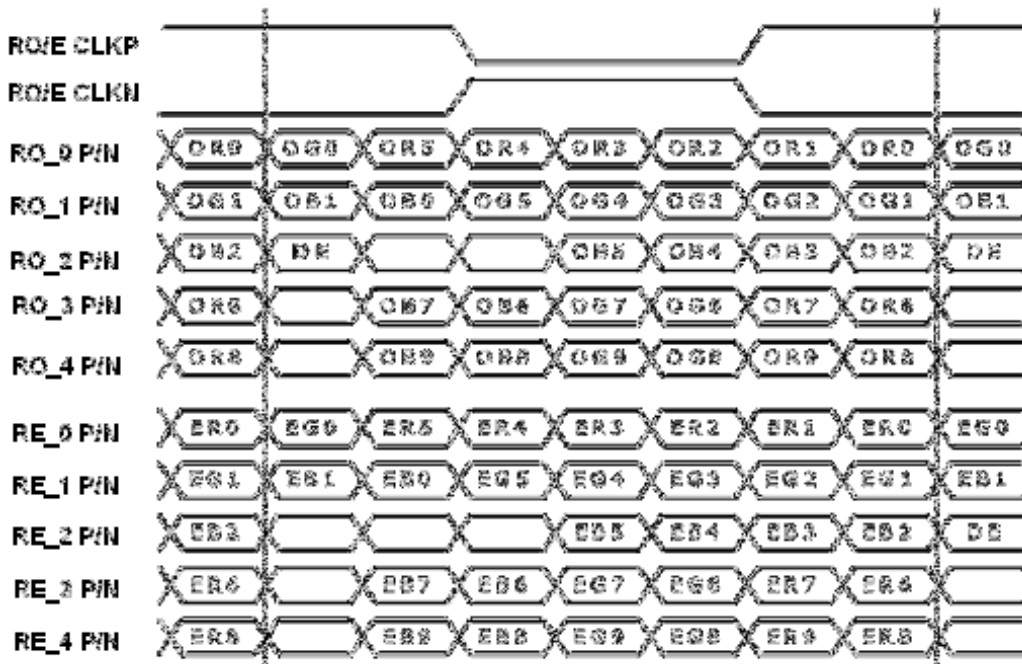

## Backlight Connector Pin Configuration

### 1. Electrical specification

| No | ITEM                         | SYMBOL        | CONDITION                        | MIN           | TYP  | MAX  | UNIT      | Note     |
|----|------------------------------|---------------|----------------------------------|---------------|------|------|-----------|----------|
| 1  | Input Voltage                | $V_{DDB}$     | ---                              | 21.6          | 24.0 | 26.4 | $V_{DC}$  |          |
| 2  | Input Current                | $I_{DDB}$     | $V_{DDB}=24V$<br>100% Brightness | 6.94          | 7.3  | 7.66 | $A_{DC}$  |          |
| 3  | Input Power                  | $P_{DDB}$     | $V_{DDB}=24V$<br>100% Brightness |               | 175  |      | W         |          |
| 4  | Input inrush current         | $I_{RUSH}$    | $V_{DDB}=24V$<br>100% Brightness |               | 8.16 |      | $A_{DC}$  |          |
| 5  | Output Frequency             | $F_{BL}$      | $V_{DDB}=24V$                    |               | 44   |      | kHz       |          |
| 6  | ON/OFF Control Voltage       | $V_{BLON}$    | ON                               | $V_{DDB}=24V$ | 2.0  | ---  | 3.3       | $V_{DC}$ |
|    |                              |               | OFF                              | $V_{DDB}=24V$ | 0.0  | ---  | 0.8       | $V_{DC}$ |
| 7  | ON/OFF Control Current       | $I_{BLON}$    | $V_{DDB}=24V$                    | 0             | ---  | 2    | $mA_{DC}$ |          |
| 8  | External PWM Control Voltage | $E_{V_{PWM}}$ | Max                              | ---           | 2.0  |      | 3.3       | V        |
|    |                              |               | Min                              | ---           | 0    |      | 0.8       | V        |
| 9  | External PWM Control Current | $E_{I_{PWM}}$ | Max                              | PWM=100%      | 0    |      | 2         | mA       |
|    |                              |               | Min                              | PWM=10%       | 0    |      | 2         | mA       |
| 10 | External PWM Duty Ratio      | $E_{D_{PWM}}$ | ---                              | 10            |      | 100  | %         |          |
| 11 | External PWM Frequency       | $E_{F_{PWM}}$ | ---                              | 120           | 180  | 300  | Hz        |          |
| 12 | Internal PWM Control Voltage | $I_{V_{PWM}}$ | $V_{DDB}$                        | 0             |      | 3.3  | V         |          |

( $T_a=25\pm 5^{\circ}C$ , Turn on for 45minutes)

\* Note : At < 20% dimming ratio, AUO would not guarantee display performance & start at High and Low Temperature condition.

## 2. Input specification

Connector : S14B-PH-SM4-TB (JST) or equivalent

| CN :S14B-PH-SM4-TB (JST) |                   |   |
|--------------------------|-------------------|---|
| No                       | Signal Name       | Feature   |
| 1                        | V <sub>DDB</sub>  | Operating Voltage Supply, +24V DC regulated   |
| 2                        | V <sub>DDB</sub>  | Operating Voltage Supply, +24V DC regulated   |
| 3                        | V <sub>DDB</sub>  | Operating Voltage Supply, +24V DC regulated   |
| 4                        | V <sub>DDB</sub>  | Operating Voltage Supply, +24V DC regulated   |
| 5                        | V <sub>DDB</sub>  | Operating Voltage Supply, +24V DC regulated   |
| 6                        | GND               | Ground and Current Return   |
| 7                        | GND               | Ground and Current Return   |
| 8                        | GND               | Ground and Current Return   |
| 9                        | GND               | Ground and Current Return   |
| 10                       | GND               | Ground and Current Return   |
| 11                       | Reserved          | Reserved  |
| 12                       | V <sub>BLOn</sub> | GND:BL Off; Open/High (3.3V):BL On  |
| 13                       | PDIM              | External PWM (AC Signal Control Duty);<br>Internal PWM (DC Power Control Duty, 0~3.3V)<br>Open/High (+3.3V, 100% Duty) for 100% |
| 14                       | PDIM Selection    | GND: External PWM dimming;<br>Open/High (3.3V):Internal PWM dimming   |

### 3-3 Signal Timing Specifications

This is the signal timing required at the input of the User connector. All of the interface signal timing should be satisfied with the following specifications for its proper operation.

Timing Table (DE only Mode)

Vertical Frequency Range A (60Hz)

| Signal               | Item      | Symbol    | Min  | Type  | Max  | Unit |
|----------------------|-----------|-----------|------|-------|------|------|
| Vertical Section     | Period    | Tv        | 1090 | 1125  | 1480 | Th   |
|                      | Active    | Tdisp (v) | 1080 |       |      | Th   |
|                      | Blanking  | Tblk (v)  | 10   | 45    | 400  | Th   |
| Horizontal Section   | Period    | Th        | 1030 | 1100  | 1300 | Tclk |
|                      | Active    | Tdisp (h) | 960  |       |      | Tclk |
|                      | Blanking  | Tblk (h)  | 70   | 140   | 340  | Tclk |
| Clock                | Period    | CLK       | 20   | 13.47 | 12.9 | ns   |
|                      | Frequency | Freq      | 50   | 74.25 | 82   | MHz  |
| Vertical Frequency   | Frequency | Vs        | 47   | 60    | 63   | Hz   |
| Horizontal Frequency | Frequency | Hs        | 60   | 67.5  | 73   | KHz  |

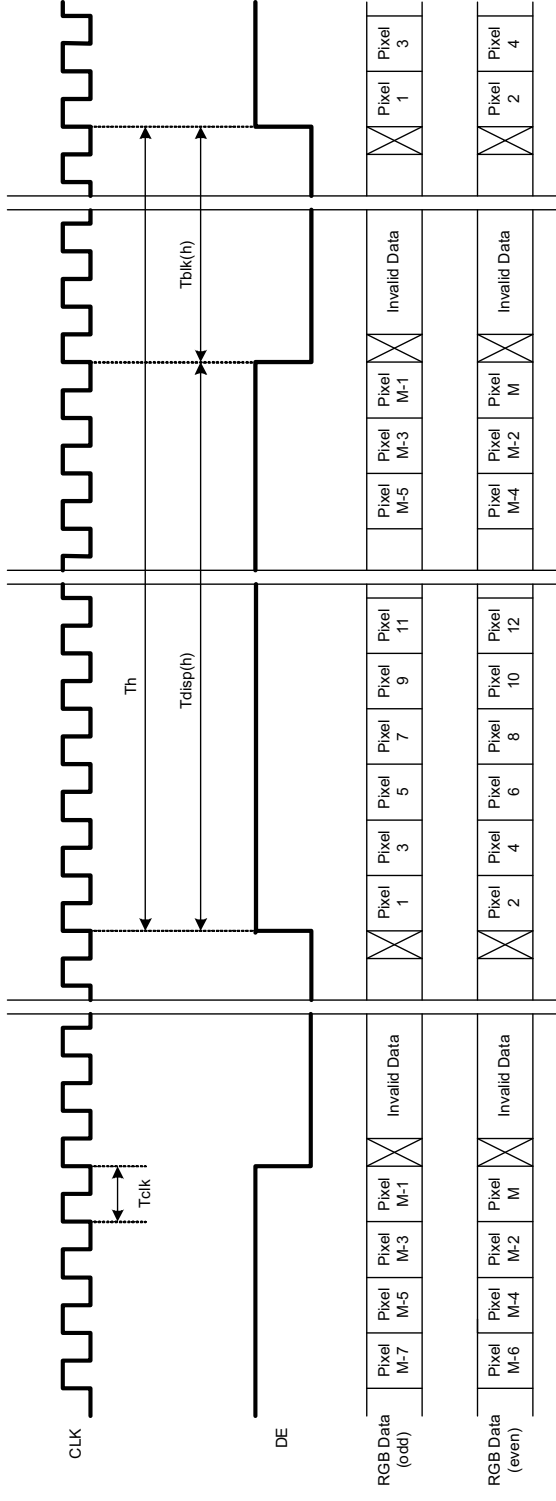
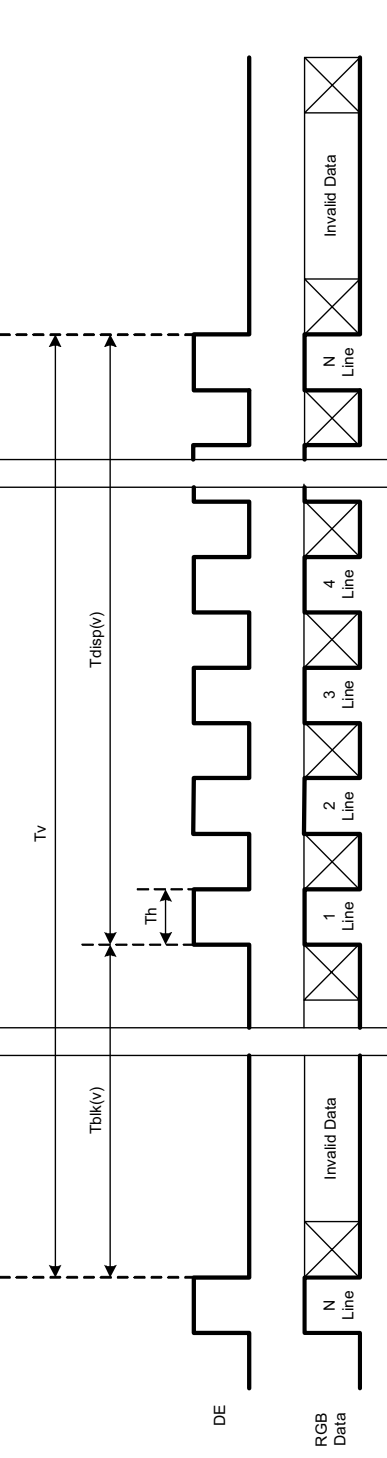

### 3-4 Signal Timing Waveforms

©Copyright AU Optonics, Inc.  
 January, 2008 All Rights Reserved.  
 No Reproduction and Redistribution Allowed

P420HW02 V0

1/3/28

### 3-5 Color Input Data Reference

The brightness of each primary color (red, green and blue) is based on the 8 bit gray scale data input for the color; the higher the binary input, the brighter the color. The table below provides a reference for color versus data input.

#### COLOR DATA REFERENCE

| Color       |            | Input Color Data |    |    |    |     |    |    |    |       |    |    |    |     |    |    |    |      |    |    |    |     |    |    |    |
|-------------|------------|------------------|----|----|----|-----|----|----|----|-------|----|----|----|-----|----|----|----|------|----|----|----|-----|----|----|----|
|             |            | RED              |    |    |    |     |    |    |    | GREEN |    |    |    |     |    |    |    | BLUE |    |    |    |     |    |    |    |
|             |            | MSB              |    |    |    | LSB |    |    |    | MSB   |    |    |    | LSB |    |    |    | MSB  |    |    |    | LSB |    |    |    |
|             |            | R7               | R6 | R5 | R4 | R3  | R2 | R1 | R0 | G7    | G6 | G5 | G4 | G3  | G2 | G1 | G0 | B7   | B6 | B5 | B4 | B3  | B2 | B1 | B0 |
| Basic Color | Black      | 0                | 0  | 0  | 0  | 0   | 0  | 0  | 0  | 0     | 0  | 0  | 0  | 0   | 0  | 0  | 0  | 0    | 0  | 0  | 0  | 0   | 0  | 0  | 0  |
|             | Red(255)   | 1                | 1  | 1  | 1  | 1   | 1  | 1  | 1  | 0     | 0  | 0  | 0  | 0   | 0  | 0  | 0  | 0    | 0  | 0  | 0  | 0   | 0  | 0  | 0  |
|             | Green(255) | 0                | 0  | 0  | 0  | 0   | 0  | 0  | 0  | 1     | 1  | 1  | 1  | 1   | 1  | 1  | 1  | 0    | 0  | 0  | 0  | 0   | 0  | 0  | 0  |
|             | Blue(255)  | 0                | 0  | 0  | 0  | 0   | 0  | 0  | 0  | 0     | 0  | 0  | 0  | 0   | 0  | 0  | 0  | 1    | 1  | 1  | 1  | 1   | 1  | 1  | 1  |
|             | Cyan       | 0                | 0  | 0  | 0  | 0   | 0  | 0  | 0  | 1     | 1  | 1  | 1  | 1   | 1  | 1  | 1  | 1    | 1  | 1  | 1  | 1   | 1  | 1  | 1  |
|             | Magenta    | 1                | 1  | 1  | 1  | 1   | 1  | 1  | 1  | 0     | 0  | 0  | 0  | 0   | 0  | 0  | 0  | 1    | 1  | 1  | 1  | 1   | 1  | 1  | 1  |
|             | Yellow     | 1                | 1  | 1  | 1  | 1   | 1  | 1  | 1  | 1     | 1  | 1  | 1  | 1   | 1  | 1  | 1  | 0    | 0  | 0  | 0  | 0   | 0  | 0  | 0  |
|             | White      | 1                | 1  | 1  | 1  | 1   | 1  | 1  | 1  | 1     | 1  | 1  | 1  | 1   | 1  | 1  | 1  | 1    | 1  | 1  | 1  | 1   | 1  | 1  | 1  |
| RED         | RED(000)   | 0                | 0  | 0  | 0  | 0   | 0  | 0  | 0  | 0     | 0  | 0  | 0  | 0   | 0  | 0  | 0  | 0    | 0  | 0  | 0  | 0   | 0  | 0  | 0  |
|             | RED(001)   | 0                | 0  | 0  | 0  | 0   | 0  | 0  | 1  | 0     | 0  | 0  | 0  | 0   | 0  | 0  | 0  | 0    | 0  | 0  | 0  | 0   | 0  | 0  | 0  |
|             | ----       |                  |    |    |    |     |    |    |    |       |    |    |    |     |    |    |    |      |    |    |    |     |    |    |    |
|             | RED(254)   | 1                | 1  | 1  | 1  | 1   | 1  | 1  | 0  | 0     | 0  | 0  | 0  | 0   | 0  | 0  | 0  | 0    | 0  | 0  | 0  | 0   | 0  | 0  | 0  |
|             | RED(255)   | 1                | 1  | 1  | 1  | 1   | 1  | 1  | 1  | 0     | 0  | 0  | 0  | 0   | 0  | 0  | 0  | 0    | 0  | 0  | 0  | 0   | 0  | 0  | 0  |
| GREEN       | GREEN(000) | 0                | 0  | 0  | 0  | 0   | 0  | 0  | 0  | 0     | 0  | 0  | 0  | 0   | 0  | 0  | 0  | 0    | 0  | 0  | 0  | 0   | 0  | 0  | 0  |
|             | GREEN(001) | 0                | 0  | 0  | 0  | 0   | 0  | 0  | 0  | 0     | 0  | 0  | 0  | 0   | 0  | 0  | 1  | 0    | 0  | 0  | 0  | 0   | 0  | 0  | 0  |
|             | ----       |                  |    |    |    |     |    |    |    |       |    |    |    |     |    |    |    |      |    |    |    |     |    |    |    |
|             | GREEN(254) | 0                | 0  | 0  | 0  | 0   | 0  | 0  | 0  | 1     | 1  | 1  | 1  | 1   | 1  | 1  | 0  | 0    | 0  | 0  | 0  | 0   | 0  | 0  | 0  |
|             | GREEN(255) | 0                | 0  | 0  | 0  | 0   | 0  | 0  | 0  | 1     | 1  | 1  | 1  | 1   | 1  | 1  | 1  | 0    | 0  | 0  | 0  | 0   | 0  | 0  | 0  |
| BLUE        | BLUE(000)  | 0                | 0  | 0  | 0  | 0   | 0  | 0  | 0  | 0     | 0  | 0  | 0  | 0   | 0  | 0  | 0  | 0    | 0  | 0  | 0  | 0   | 0  | 0  | 0  |
|             | BLUE(001)  | 0                | 0  | 0  | 0  | 0   | 0  | 0  | 0  | 0     | 0  | 0  | 0  | 0   | 0  | 0  | 0  | 0    | 0  | 0  | 0  | 0   | 0  | 0  | 1  |
|             | -----      |                  |    |    |    |     |    |    |    |       |    |    |    |     |    |    |    |      |    |    |    |     |    |    |    |
|             | BLUE(254)  | 0                | 0  | 0  | 0  | 0   | 0  | 0  | 0  | 0     | 0  | 0  | 0  | 0   | 0  | 0  | 0  | 1    | 1  | 1  | 1  | 1   | 1  | 1  | 0  |
|             | BLUE(255)  | 0                | 0  | 0  | 0  | 0   | 0  | 0  | 0  | 0     | 0  | 0  | 0  | 0   | 0  | 0  | 0  | 1    | 1  | 1  | 1  | 1   | 1  | 1  | 1  |

### 3-6 Power Sequence

#### 1. Power sequence of panel

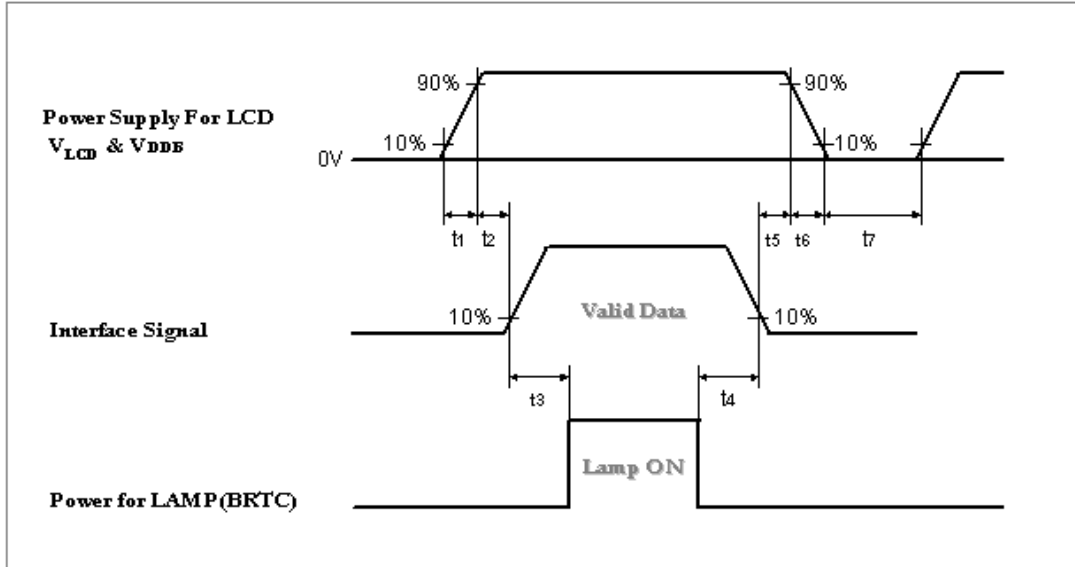

| Parameter | Values |      |      | Units |
|-----------|--------|------|------|-------|
|           | Min.   | Typ. | Max. |       |
| t1        | 0.4    | -    | 30   | ms    |
| t2        | 0.1    | -    | 50   | ms    |
| t3        | 300    | -    | -    | ms    |
| t4        | 100    | -    | -    | ms    |
| t5        | 0.1    | -    | 50   | ms    |
| t6        |        | -    | 300  | ms    |
| t7        | 500    | -    | -    | ms    |

Apply the lamp voltage within the LCD operating range. When the backlight turns on before the LCD operation or the LCD turns off before the backlight turns off, the display may momentarily become abnormal.

**Caution:** The above on/off sequence should be applied to avoid abnormal function in the display. In case of handling, make sure to turn off the power when you plug the cable into the input connector or pull the cable out of the connector.



2. Power sequence of inverter

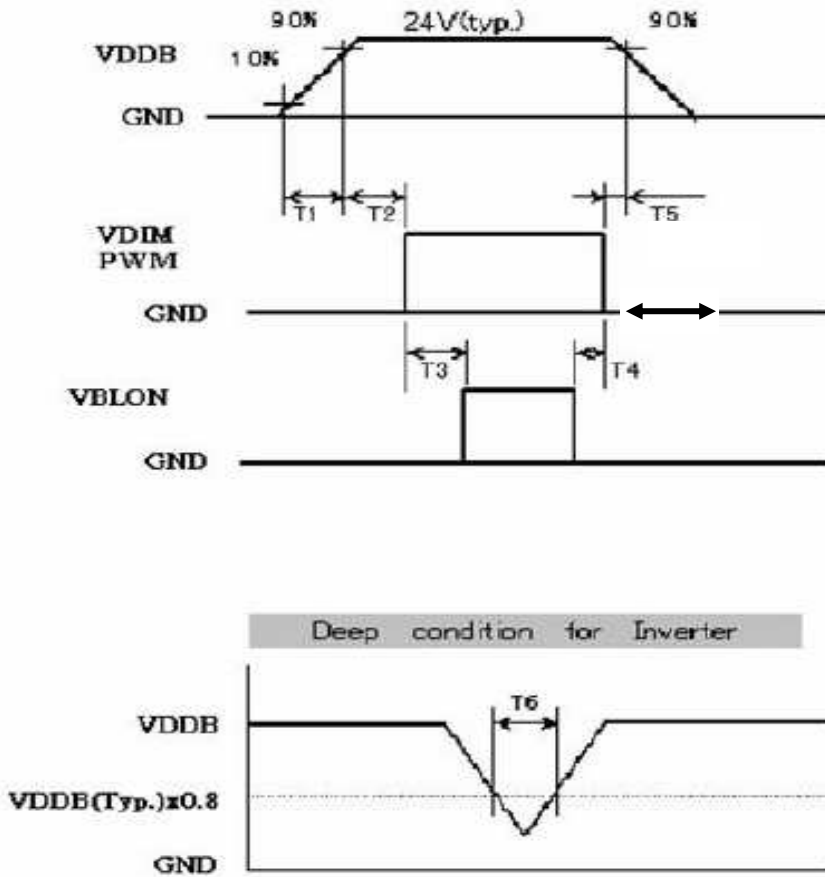

| Parameter | Values |      |      | Units |
|-----------|--------|------|------|-------|
|           | Min.   | Typ. | Max. |       |
| T1        | 20     | -    | -    | ms    |
| T2        | 500    | -    | -    | ms    |
| T3        | 250    | -    | -    | ms    |
| T4        | 0      | -    | -    | ms    |
| T5        | 1      | -    | -    | ms    |
| T6        |        |      | 10   | ms    |

## 4. Optical Specification

Optical characteristics are determined after the unit has been 'ON' and stable for approximately 60 minutes in a dark environment at 25°C. The values specified are at an approximate distance 50cm from the LCD surface at a viewing angle of  $\Phi$  and  $\theta$  equal to 0°.

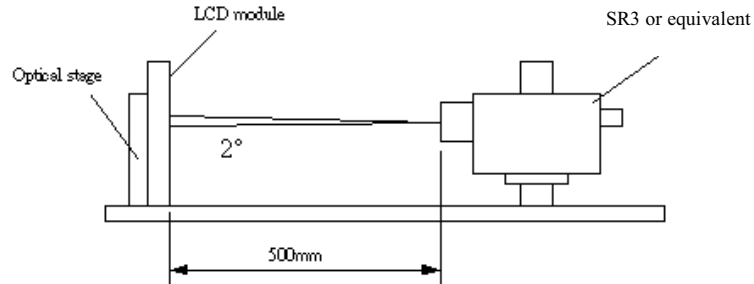

Fig.4-1 Optical measurement equipment and method

| Parameter                           | Symbol                       | Values    |       |           | Units             | Notes              |
|-------------------------------------|------------------------------|-----------|-------|-----------|-------------------|--------------------|
|                                     |                              | Min.      | Typ.  | Max.      |                   |                    |
| Contrast Ratio                      | CR                           | 2500      | 3500  |           |                   | 1                  |
| Surface Luminance, white            | LWH                          | 550       | 700   |           | cd/m <sup>2</sup> | 2                  |
| Luminance Variation                 | $\delta_{\text{WHITE}}$   5p |           |       | 1.3       |                   | 3                  |
| Response Time (Average)             | T $\gamma$                   |           | 8     |           | ms                | 4,5 (Gray to Gray) |
| Color Coordinates                   |                              |           |       |           |                   |                    |
| RED                                 | R <sub>x</sub>               | Typ.-0.03 | 0.640 | Typ.+0.03 |                   |                    |
|                                     | R <sub>y</sub>               |           | 0.330 |           |                   |                    |
| GREEN                               | G <sub>x</sub>               |           | 0.290 |           |                   |                    |
|                                     | G <sub>y</sub>               |           | 0.600 |           |                   |                    |
| BLUE                                | B <sub>x</sub>               |           | 0.150 |           |                   |                    |
|                                     | B <sub>y</sub>               |           | 0.060 |           |                   |                    |
| WHITE                               | W <sub>x</sub>               |           | 0.280 |           |                   |                    |
|                                     | W <sub>y</sub>               |           | 0.290 |           |                   |                    |
| Viewing Angle                       |                              |           |       |           |                   |                    |
| x axis, right( $\varphi=0^\circ$ )  | $\theta_r$                   |           | 89    |           | Degree            | 6                  |
| x axis, left( $\varphi=180^\circ$ ) | $\theta_l$                   |           | 89    |           |                   |                    |
| y axis, up( $\varphi=90^\circ$ )    | $\theta_u$                   |           | 89    |           |                   |                    |
| y axis, down ( $\varphi=0^\circ$ )  | $\theta_d$                   |           | 89    |           |                   |                    |

Note:

1. Contrast Ratio (CR) is defined mathematically as:

$$\text{Contrast ratio (CR)} = \frac{\text{Brightness on the "white" state}}{\text{Brightness on the "black" state}}$$

2. Surface luminance is luminance value at point 1 across the LCD surface 50cm from the surface with all pixels displaying white. From more information see Fig. 4-2. When  $V_{DDB} = 24V$ ,  $I_{DDB} = 7.3A$ .  $L_{WH} = L_{on1}$ , Where  $L_{on1}$  is the luminance with all pixels displaying white at center 1 location.

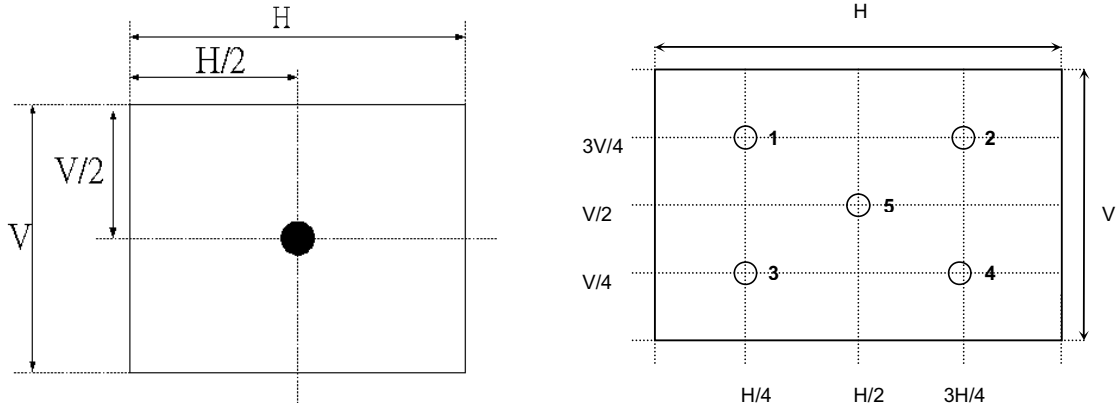

**Fig.4-2 Optical measurement point**

3. The variation in surface luminance,  $\delta_{WHITE}$  is defined under 100% brightness as:

$$\delta_{WHITE(5P)} = \frac{\text{Maximum}(L_{on1}, L_{on2}, \dots, L_{on5})}{\text{Minimum}(L_{on1}, L_{on2}, \dots, L_{on5})}$$

4. Response Time:

(a) G-to-G: average response time among brightness of 0%, 25%, 50%, 75% & 100%.

|      | 0%          | 25%          | 50%          | 75%          | 100%         |
|------|-------------|--------------|--------------|--------------|--------------|
| 0%   |             | tr: 0%→25%   | tr: 0%→50%   | tr: 0%→75%   | tr: 0%→100%  |
| 25%  | tf: 25%→0%  |              | tr: 25%→50%  | tr: 25%→75%  | tr: 25%→100% |
| 50%  | tf: 50%→0%  | tf: 50%→25%  |              | tr: 50%→75%  | tr: 50%→100% |
| 75%  | tf: 75%→0%  | tf: 75%→25%  | tf: 75%→50%  |              | tr: 75%→100% |
| 100% | tf: 100%→0% | tf: 100%→25% | tf: 100%→50% | tf: 100%→75% |              |

5. Viewing angle is the angle at which the contrast ratio is greater than 10. The angles are determined for the horizontal or x axis and the vertical or y axis with respect to the z axis which is normal to the LCD surface. For more information see Fig. 4-3. (Optical measurement by SR3)

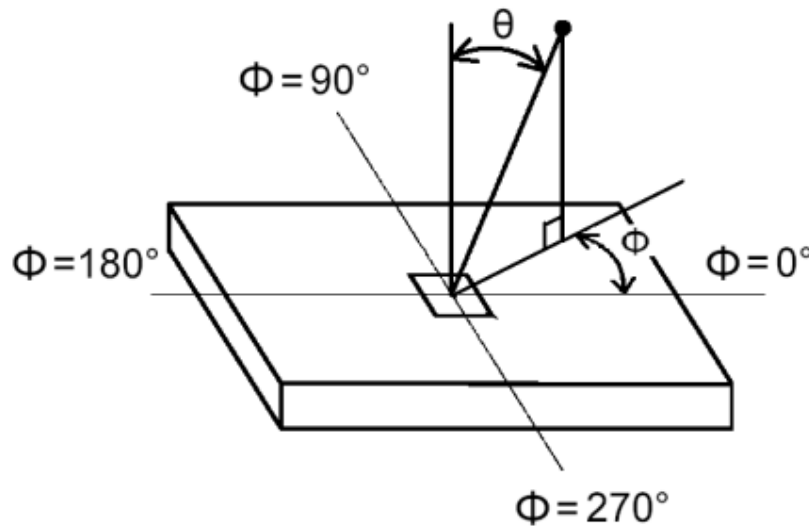

**Fig.4-3 Viewing Angle Definition**

## 5. Mechanical Characteristics

The contents provide general mechanical characteristics for the model P420HW02. In addition the figures in the next page are detailed mechanical drawing of the LCD.

|                     |  |                        |
|---------------------|--|------------------------|
| Outline Dimension   | Horizontal (typ.)                                  | 957.45mm               |
|                     | Vertical (typ.)                                    | 550.2mm                |
|                     | Depth (typ.)                                       | 52.7mm (with inverter) |
| Bezel Area          | Horizontal (typ.)                                  | 938.95mm               |
|                     | Vertical (typ.)                                    | 531.01mm               |
| Active Display Area | Horizontal   | 930.24mm               |
|                     | Vertical   | 523.26mm               |
| Weight              | 11100 (typ),                                       |                        |
| Surface Treatment   | Anti-Glare coating (Haze 11%)<br>Hard coating (3H) |                        |

# 2D drawing

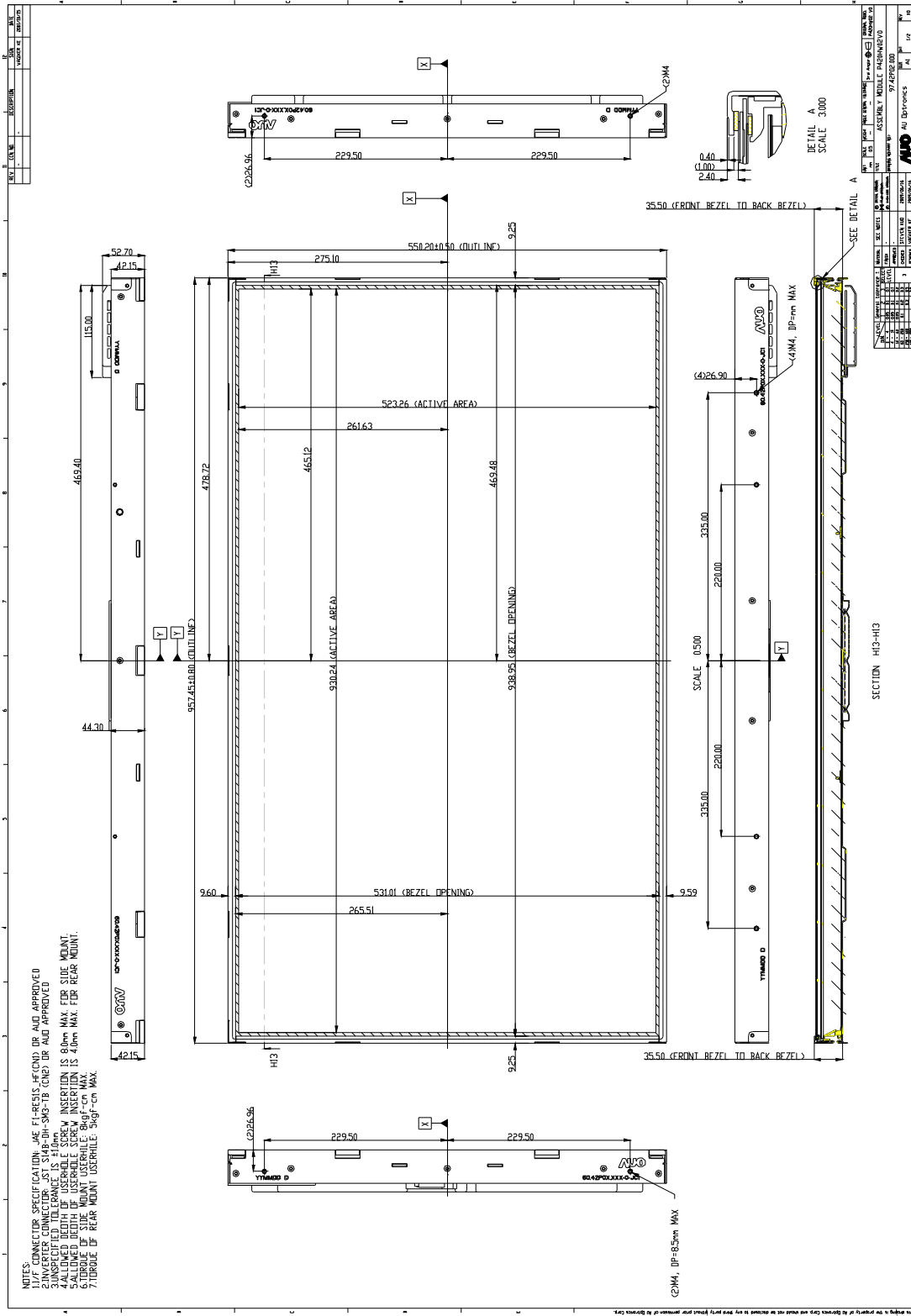

©Copyright AU Optronics, Inc.  
 January, 2008 All Rights Reserved.  
 No Reproduction and Redistribution Allowed

P420HW02 V0

21/28

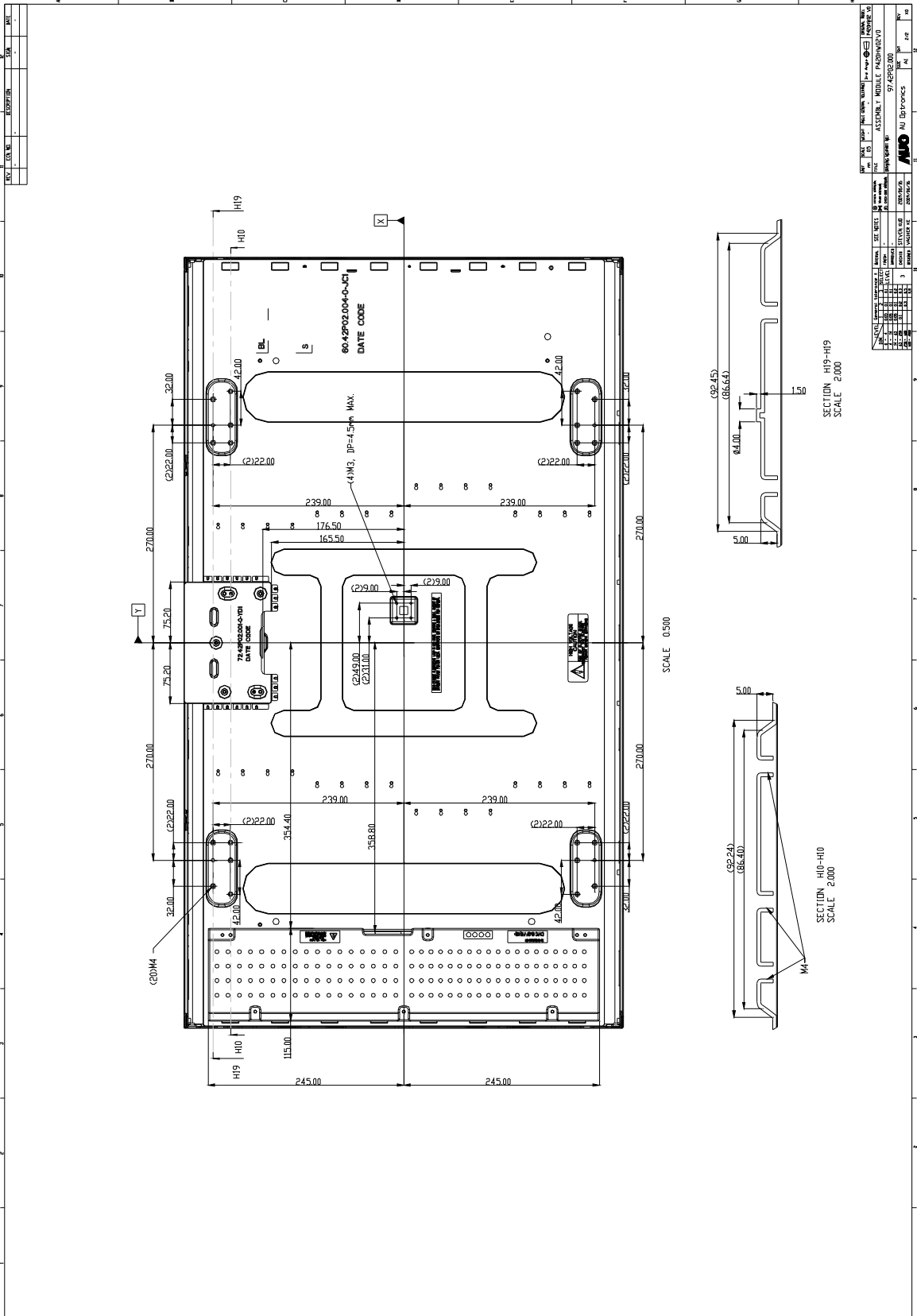

|      |          |                              |    |     |
|------|----------|------------------------------|----|-----|
| REV. | DATE     | DESCRIPTION                  | BY | CHK |
| 1    | 08/16/08 | ASSSEMBLY MODULE P420HW02 V0 |    |     |
| 2    | 08/16/08 | REVISED                      |    |     |
| 3    | 08/16/08 | REVISED                      |    |     |
| 4    | 08/16/08 | REVISED                      |    |     |
| 5    | 08/16/08 | REVISED                      |    |     |

97-A-0P02.000  
 AUO AU Optronics

©Copyright AU Optronics, Inc.  
 January, 2008 All Rights Reserved.  
 No Reproduction and Redistribution Allowed

P420HW02 V0

22/28

## 6. Reliability

Panel condition in RA test

Brightness: 700nits

| No | Test Item                         | Condition  |
|----|-----------------------------------|--|
| 1  | High temperature storage test     | Ta=60°C 500h   |
| 2  | Low temperature storage test      | Ta= -20°C 500h   |
| 3  | High temperature operation test   | Ta=50°C 500h   |
| 4  | Low temperature operation test    | Ta=-5°C 500h   |
| 5  | Vibration test<br>(non-operating) | Wave form: random<br>Vibration level: 1.5G RMS<br>Bandwidth: 10-300Hz,<br>Duration: X, Y, Z 30min<br>One time each direction |
| 6  | Shock test<br>(non-operating)     | Shock level: 40G<br>Waveform: half sine wave, 11ms<br>Direction: ±X, ±Y, ±Z<br>One time each direction                       |
| 7  | Vibration test<br>(with carton)   | Wave form: random<br>Vibration level: 1.5G RMS<br>Bandwidth: 10-200Hz,<br>Duration: X, Y, Z 30min<br>One time each direction |
| 8  | Drop test<br>(with carton)        | Height: 30.5cm<br>1 corner, 3 edges, 6 surfaces<br>(ASTMD4169-I)   |

### Result Evaluation Criteria

There should be no change which might affect the practical display function when the display quality test is conducted under normal operating condition.



## 7. International Standard

### 7-1. Safety

- (1) UL60065, Underwriters Laboratories, Inc. (AUO file number : E204356)  
Standard for Safety of Information Technology Equipment Including electrical Business Equipment.
- (2) CSA E60065, Canadian Standards Association  
Standard for Safety of Information Technology Equipment Including Electrical Business Equipment.
- (3) IEC 60065 ver. 7<sup>th</sup>, European Committee for Electro technical Standardization (CENELEC)  
EUROPEAN STANDARD for Safety of Information Technology Equipment Including Electrical Business Equipment.

### 7-2. EMC

- (1) ANSI C63.4 "Methods of Measurement of Radio-Noise Emissions from Low-Voltage Electrical and Electrical Equipment in the Range of 9kHz to 40GHz. "American National standards Institute(ANSI), 1992
- (2) C.I.S.P.R "Limits and Methods of Measurement of Radio Interface Characteristics of Information Technology Equipment." International Special committee on Radio Interference.
- (3) EN 55022 "Limits and Methods of Measurement of Radio Interface Characteristics of Information Technology Equipment." European Committee for Electrotechnical Standardization. (CENELEC), 1998

**8. Packing :** Packing Instruction

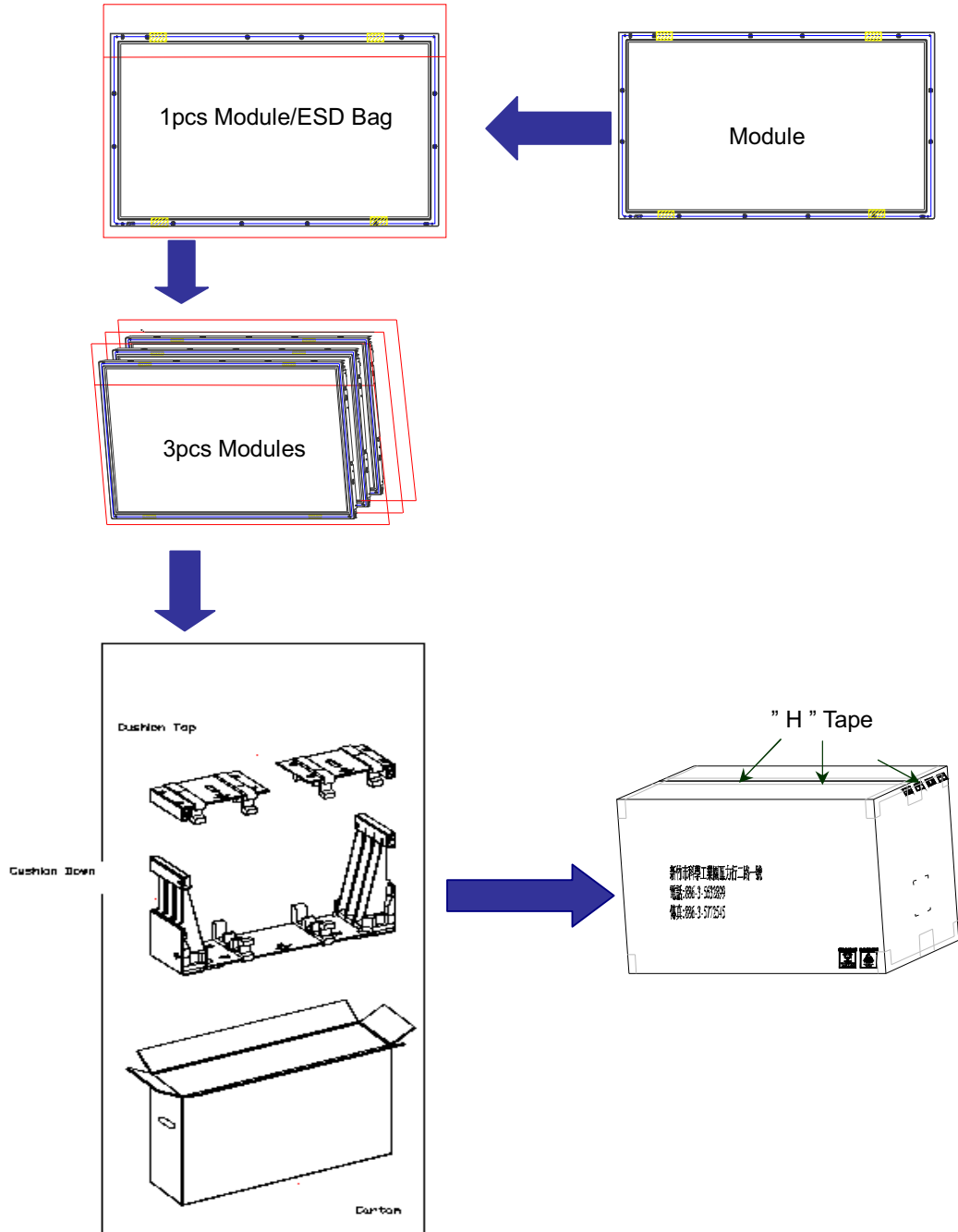

**Package Information:**

Carton outside dimension: 1050(L)mm× 277(W)mm× 650(H)mm

Carton/Package weight: 5kg

©Copyright AU Optronics, Inc.  
 January, 2008 All Rights Reserved.  
 No Reproduction and Redistribution Allowed

P420HW02 V0

25/28

Gross weight (per Box): 41kg

**Shipping label**

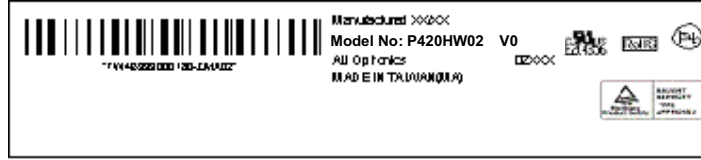

**Green Mark Description:**

For Pb Free products, AUO will add  for identification.

For RoHS compatible products, AUO will add  for identification.

**Note:** The Green Mark will be present only when the green documents have been ready by AUO Internal Green Team. (The definition of green design follows the AUO green design checklist.)

**Carton label**

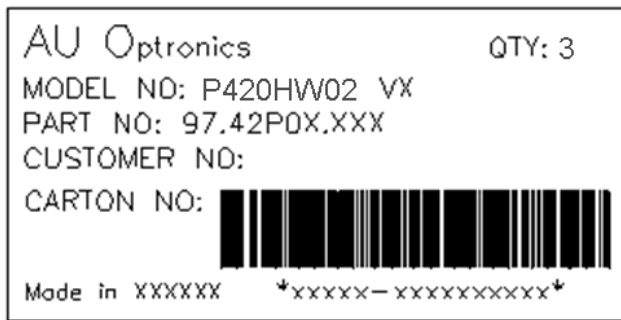

**Pallet information**

By air cargo : (4x1) x2 layers, one pallet put 8 boxes, total 24 pcs module.

By sea: (4x1) x3 layers, one pallet put 12 boxes, total 36 pcs module.

Pallet dimension : 1140mm× 1060mm× 132mm

Pallet weight: 15.5kg

By air total weight: 41 kg/box X 8 boxes=328 kg (with pallet weight 343.5 kg)

By sea total weight: 41 kg/box X 12 boxes=492 kg (with pallet weight 507.5 kg)

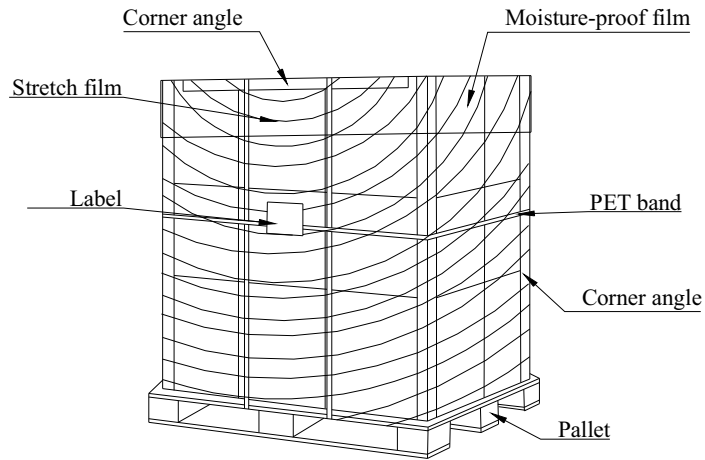

## 9. PRECAUTIONS

Please pay attention to the followings when you use this TFT LCD module.

### 9-1 MOUNTING PRECAUTIONS

- (1) You must mount a module using holes arranged on back side of panel.
- (2) Please attach the surface transparent protective plate to the surface in order to protect the polarizer. Transparent protective plate should have sufficient strength in order to resist external force.
- (3) You should adopt radiation structure to satisfy the temperature specification.
- (4) Acetic acid type and chlorine type materials for the cover case are not desirable because the former generates corrosive gas of attacking the polarizer at high temperature and the latter causes circuit break by electro-chemical reaction.
- (5) Do not touch, push or rub the exposed polarizers with glass, tweezers or anything harder than HB pencil lead. And please do not rub with dust clothes with chemical treatment. Do not touch the surface of polarizer for bare hand or greasy cloth. (Some cosmetics are detrimental to the polarizer.)
- (6) When the surface becomes dusty, please wipe gently with absorbent cotton or other soft materials like chamois soaked with petroleum benzene. Normal-hexane is recommended for cleaning the adhesives used to attach front/ rear polarizers. Do not use acetone, toluene and alcohol because they cause chemical damage to the polarizer.
- (7) Wipe off saliva or water drops as soon as possible. Their long time contact with polarizer causes deformations and color fading.
- (8) Do not open the case because inside circuits do not have sufficient strength.

## 9-2 OPERATING PRECAUTIONS

- (1) The spike noise causes the mis-operation of circuits. It should be lower than following voltage:  
 $V=\pm 200\text{mV}$ (Over and under shoot voltage)
- (2) Response time depends on the temperature. (In lower temperature, it becomes longer..)
- (3) Brightness depends on the temperature. (In lower temperature, it becomes lower.) And in lower temperature, response time (required time that brightness is stable after turned on) becomes longer.
- (4) Be careful for condensation at sudden temperature change. Condensation makes damage to polarizer or electrical contacted parts. And after fading condensation, smear or spot will occur.
- (5) When fixed patterns are displayed for a long time, remnant image is likely to occur.
- (6) Module has high frequency circuits. Sufficient suppression to the electromagnetic interference shall be done by system manufacturers. Grounding and shielding methods may be important to minimize the interface.

## 9-3 ELECTROSTATIC DISCHARGE CONTROL

Since a module is composed of electronic circuits, it is not strong to electrostatic discharge. Make certain that treatment persons are connected to ground through wrist band etc. And don't touch interface pin directly.

## 9-4 PRECAUTIONS FOR STRONG LIGHT EXPOSURE

Strong light exposure causes degradation of polarizer and color filter.

## 9-5 STORAGE

When storing modules as spares for a long time, the following precautions are necessary.

- (1) Store them in a dark place. Do not expose the module to sunlight or fluorescent light. Keep the temperature between  $5^{\circ}\text{C}$  and  $35^{\circ}\text{C}$  at normal humidity.
- (2) The polarizer surface should not come in contact with any other object. It is recommended that they be stored in the container in which they were shipped.

## 9-6 HANDLING PRECAUTIONS FOR PROTECTION FILM

- (1) The protection film is attached to the bezel with a small masking tape. When the protection film is peeled off, static electricity is generated between the film and polarizer. This should be peeled off slowly and carefully by people who are electrically grounded and with well ion-blown equipment or in such a condition, etc.
- (2) When the module with protection film attached is stored for a long time, sometimes there

remains a very small amount of glue still on the Bezel after the protection film is peeled off.

- (3) You can remove the glue easily. When the glue remains on the Bezel or its vestige is recognized, please wipe them off with absorbent cotton waste or other soft material like chamois soaked with normal-hexane.

### **9-7 Operating Condition in PID Application**

- (1) If the continuous static display is required, periodically inserting a motion picture is strongly recommended.
- (2) Recommend to periodically change the background color and background image.
- (3) Recommend not to continuously operate over 18 hours a day.
- (4) Recommend to adopt one of the following actions after long time display.
  - I. Running the screen saver (motion picture or black pattern)
  - II. Power off the system for a while
- (5) Try not to run the LCD in a closed environment. Suitable venting on the system cover would be helpful for cooling.
- (6) It is better to adapt active cooling with fans for long time displaying, especially for high luminance LCD model.