

USER'S MANUAL

OMNUC W SERIES

MODELS R88M-W□
(AC Servomotors)

MODELS R88D-WT□
(AC Servo Drivers)

AC SERVOMOTORS/SERVO DRIVERS

Thank you for choosing this OMNUC W-series product. Proper use and handling of the product will ensure proper product performance, will length product life, and may prevent possible accidents.

Please read this manual thoroughly and handle and operate the product with care.

1. To ensure safe and proper use of your OMRON Servomotors and Servo Drivers, please read this manual (Cat. No. I531-E1) to gain sufficient knowledge of the products, safety information, and precautions before actual use.
2. The products are illustrated without covers and shieldings to enable showing better detail in this manual. For actual use of the products, make sure to use the covers and shieldings as specified.
3. Copies of this manual and other related manuals must be delivered to the actual end users of the products.
4. Please keep a copy of this manual close at hand for future reference.
5. If a product has been left unused for a long time, please consult with your OMRON sales representative.

NOTICE

1. This manual describes the functions of the product and relations with other products. You should assume that anything not described in this manual is not possible.
2. Although care has been given in documenting the product, please contact your OMRON representative if you have any suggestions on improving this manual.
3. The product contains dangerous high voltages inside. Turn OFF the power and wait for at least five minutes to allow power to discharge before handling or working with the product. Never attempt to disassemble the product.
4. We recommend that you add the following precautions to any instruction manuals you prepare for the system into which the product is being installed.
 - Precautions on the dangers of high-voltage equipment.
 - Precautions on touching the terminals of the product even after power has been turned OFF. (These terminals are live even with the power turned OFF.)
5. Specifications and functions may be changed without notice in order to improve product performance.
6. Positive and negative rotation of AC Servomotors described in this manual are defined as looking at the end of the output shaft of the motor as follows: counterclockwise rotation is positive and clockwise rotation is negative.
7. Do not perform withstand-voltage or other megameter tests on the product. Doing so may damage internal components.
8. Servomotors and Servo Drivers have a finite service life. Be sure to keep replacement products on hand and to consider the operating environment and other conditions affecting the service life.
9. The OMNUC W Series can control both incremental and absolute encoders. Differences in functions or specifications according to the encoder type are indicated in this manual. Be sure to check the model that is being used, and follow the relevant specifications.
 - Servomotors with incremental encoders: R88M-W□H-□/-W□L-□
 - Servomotors with absolute encoders: R88M-W□T-□/-W□S-□

Items to Check After Unpacking

Check the following items after removing the product from the package:

- Has the correct product been delivered (i.e., the correct model number and specifications)?
- Has the product been damaged in shipping?
- Are any screws or bolts loose?

OMRON

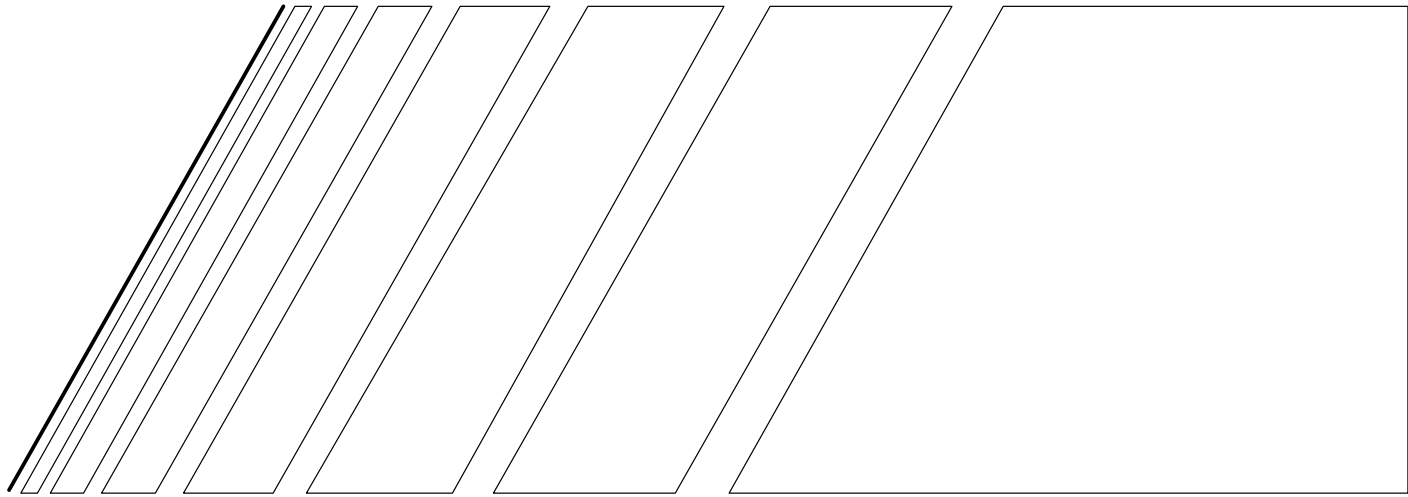

USER'S MANUAL

OMNUC W SERIES

MODELS R88M-W□
(AC Servomotors)

MODELS R88D-WT□
(AC Servo Drivers)

AC SERVOMOTORS/SERVO DRIVERS

Notice:

OMRON products are manufactured for use according to proper procedures by a qualified operator and only for the purposes described in this manual.

The following conventions are used to indicate and classify precautions in this manual. Always heed the information provided with them. Failure to heed precautions can result in injury to people or damage to property.

 **DANGER** Indicates an imminently hazardous situation which, if not avoided, will result in death or serious injury. Additionally, there may be severe property damage.

 **WARNING** Indicates a potentially hazardous situation which, if not avoided, could result in death or serious injury. Additionally, there may be severe property damage.

 **Caution** Indicates a potentially hazardous situation which, if not avoided, may result in minor or moderate injury, or property damage.

OMRON Product References

All OMRON products are capitalized in this manual. The word “Unit” is also capitalized when it refers to an OMRON product, regardless of whether or not it appears in the proper name of the product.

The abbreviation “Ch,” which appears in some displays and on some OMRON products, often means “word” and is abbreviated “Wd” in documentation in this sense.

The abbreviation “PLC” means Programmable Controller and is not used as an abbreviation for anything else.

Visual Aids

The following headings appear in the left column of the manual to help you locate different types of information.

Note Indicates information of particular interest for efficient and convenient operation of the product.

© OMRON, 2000

All rights reserved. No part of this publication may be reproduced, stored in a retrieval system, or transmitted, in any form, or by any means, mechanical, electronic, photocopying, recording, or otherwise, without the prior written permission of OMRON.











No patent liability is assumed with respect to the use of the information contained herein. Moreover, because OMRON is constantly striving to improve its high-quality products, the information contained in this manual is subject to change without notice. Every precaution has been taken in the preparation of this manual. Nevertheless, OMRON assumes no responsibility for errors or omissions. Neither is any liability assumed for damages resulting from the use of the information contained in this publication.

General Warnings

Observe the following warnings when using the OMNUC Servomotor and Servo Driver and all connected or peripheral devices.

This manual may include illustrations of the product with protective covers removed in order to describe the components of the product in detail. Make sure that these protective covers are on the product before use.

Consult your OMRON representative when using the product after a long period of storage.

-  **WARNING** Always connect the frame ground terminals of the Servo Driver and the Servomotor to a class-3 ground (to 100 Ω or less). Not connecting to a class-3 ground may result in electric shock.
-  **WARNING** Do not touch the inside of the Servo Driver. Doing so may result in electric shock.
-  **WARNING** Do not remove the front cover, terminal covers, cables, Parameter Units, or optional items while the power is being supplied. Doing so may result in electric shock.
-  **WARNING** Installation, operation, maintenance, or inspection must be performed by authorized personnel. Not doing so may result in electric shock or injury.
-  **WARNING** Wiring or inspection must not be performed for at least five minutes after turning OFF the power supply. Doing so may result in electric shock.
-  **WARNING** Do not damage, press, or put excessive stress or heavy objects on the cables. Doing so may result in electric shock.
-  **WARNING** Do not touch the rotating parts of the Servomotor in operation. Doing so may result in injury.
-  **WARNING** Do not modify the product. Doing so may result in injury or damage to the product.
-  **Caution** Use the Servomotors and Servo Drivers in a specified combination. Using them incorrectly may result in fire or damage to the products.
-  **Caution** Do not store or install the product in the following places. Doing so may result in fire, electric shock, or damage to the product.
 - Locations subject to direct sunlight.
 - Locations subject to temperatures or humidity outside the range specified in the specifications.
 - Locations subject to condensation as the result of severe changes in temperature.
 - Locations subject to corrosive or flammable gases.
 - Locations subject to dust (especially iron dust) or salts.
 - Locations subject to shock or vibration.
 - Locations subject to exposure to water, oil, or chemicals.

 **Caution** Do not touch the Servo Driver radiator, regeneration resistors or Servomotor while the power is being supplied or soon after the power is turned OFF. Doing so may result in a burn injury due to the hot surface.

Storage and Transportation Precautions

 **Caution** Do not hold the product by the cables or motor shaft while transporting it. Doing so may result in injury or malfunction.

 **Caution** Do not place any load exceeding the figure indicated on the product. Doing so may result in injury or malfunction.

 **Caution** Use the motor eye-bolts only for transporting the Motor. Using them for transporting the machinery may result in injury or malfunction.

Installation and Wiring Precautions

 **Caution** Do not step on or place a heavy object on the product. Doing so may result in injury.

 **Caution** Do not cover the inlet or outlet ports and prevent any foreign objects from entering the product. Doing so may result in fire.

 **Caution** Be sure to install the product in the correct direction. Not doing so may result in malfunction.

 **Caution** Provide the specified clearances between the Servo Driver and the control panel or with other devices. Not doing so may result in fire or malfunction.







 **Caution** Do not apply any strong impact. Doing so may result in malfunction.

 **Caution** Be sure to wire correctly and securely. Not doing so may result in motor runaway, injury, or malfunction.







 **Caution** Be sure that all the mounting screws, terminal screws, and cable connector screws are tightened to the torque specified in the relevant manuals. Incorrect tightening torque may result in malfunction.

 **Caution** Use crimp terminals for wiring. Do not connect bare stranded wires directly to terminals. Connection of bare stranded wires may result in burning.

 **Caution** Always use the power supply voltage specified in the User's Manual. An incorrect voltage may result in malfunction or burning.

-  **Caution** Take appropriate measures to ensure that the specified power with the rated voltage and frequency is supplied. Be particularly careful in places where the power supply is unstable. An incorrect power supply may result in malfunction.
-  **Caution** Install external breakers and take other safety measures against short-circuiting in external wiring. Insufficient safety measures against short-circuiting may result in burning.
-  **Caution** Provide an appropriate stopping device on the machine side to secure safety. (A holding brake is not a stopping device for securing safety.) Not doing so may result in injury.
-  **Caution** Provide an external emergency stopping device that allows an instantaneous stop of operation and power interruption. Not doing so may result in injury.
-  **Caution** Take appropriate and sufficient countermeasures when installing systems in the following locations:
- Locations subject to static electricity or other forms of noise.
 - Locations subject to strong electromagnetic fields and magnetic fields.
 - Locations subject to possible exposure to radioactivity.
 - Locations close to power supplies.
-  **Caution** Do not reverse the polarity of the battery when connecting it. Reversing the polarity may damage the battery or cause it to explode.

Operation and Adjustment Precautions

-  **Caution** Confirm that no adverse effects will occur in the system before performing the test operation. Not doing so may result in equipment damage.
-  **Caution** Confirm that no adverse effects will occur in the system before performing the test operation. Not doing so may result in equipment damage.
-  **Caution** Check the newly set parameters for proper execution before actually running them. Not doing so may result in equipment damage.
-  **Caution** Do not make any extreme adjustments or setting changes. Doing so may result in unstable operation and injury.
-  **Caution** Separate the Servomotor from the machine, check for proper operation, and then connect to the machine. Not doing so may cause injury.
-  **Caution** When an alarm occurs, remove the cause, reset the alarm after confirming safety, and then resume operation. Not doing so may result in injury.

 **Caution** Do not come close to the machine immediately after resetting momentary power interruption to avoid an unexpected restart. (Take appropriate measures to secure safety against an unexpected restart.) Doing so may result in injury.

 **Caution** Do not use the built-in brake of the Servomotor for ordinary braking. Doing so may result in malfunction.

Maintenance and Inspection Precautions

 **WARNING** Do not attempt to disassemble, repair, or modify any Units. Any attempt to do so may result in malfunction, fire, or electric shock.

 **Caution** Resume operation only after transferring to the new Unit the contents of the data required for operation. Not doing so may result in an unexpected operation.

Warning Labels

Warning labels are pasted on the product as shown in the following illustration. Be sure to follow the instructions given there.

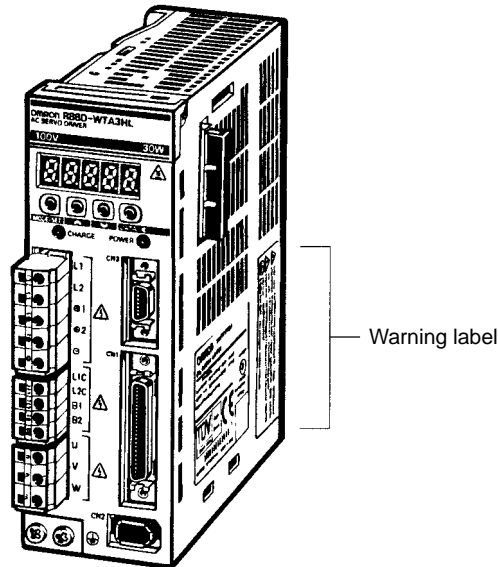

Example from R88D-WTA3HL

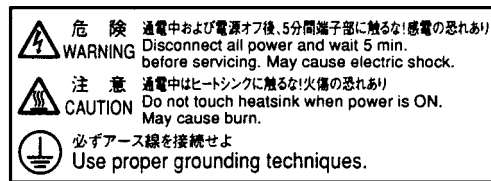

Example from R88D-WTA3HL

Precautions for Safe Use

Dispose of the product and batteries according to local ordinances as they apply. Have qualified specialists properly dispose of used batteries as industrial waste.



廃電池請回収

Read and Understand this Manual

Please read and understand this manual before using the product. Please consult your OMRON representative if you have any questions or comments.

Warranty and Limitations of Liability

WARRANTY

OMRON's exclusive warranty is that the products are free from defects in materials and workmanship for a period of one year (or other period if specified) from date of sale by OMRON.

OMRON MAKES NO WARRANTY OR REPRESENTATION, EXPRESS OR IMPLIED, REGARDING NON-INFRINGEMENT, MERCHANTABILITY, OR FITNESS FOR PARTICULAR PURPOSE OF THE PRODUCTS. ANY BUYER OR USER ACKNOWLEDGES THAT THE BUYER OR USER ALONE HAS DETERMINED THAT THE PRODUCTS WILL SUITABLY MEET THE REQUIREMENTS OF THEIR INTENDED USE. OMRON DISCLAIMS ALL OTHER WARRANTIES, EXPRESS OR IMPLIED.

LIMITATIONS OF LIABILITY

OMRON SHALL NOT BE RESPONSIBLE FOR SPECIAL, INDIRECT, OR CONSEQUENTIAL DAMAGES, LOSS OF PROFITS OR COMMERCIAL LOSS IN ANY WAY CONNECTED WITH THE PRODUCTS, WHETHER SUCH CLAIM IS BASED ON CONTRACT, WARRANTY, NEGLIGENCE, OR STRICT LIABILITY.

In no event shall the responsibility of OMRON for any act exceed the individual price of the product on which liability is asserted.

IN NO EVENT SHALL OMRON BE RESPONSIBLE FOR WARRANTY, REPAIR, OR OTHER CLAIMS REGARDING THE PRODUCTS UNLESS OMRON'S ANALYSIS CONFIRMS THAT THE PRODUCTS WERE PROPERLY HANDLED, STORED, INSTALLED, AND MAINTAINED AND NOT SUBJECT TO CONTAMINATION, ABUSE, MISUSE, OR INAPPROPRIATE MODIFICATION OR REPAIR.

Application Considerations

SUITABILITY FOR USE

OMRON shall not be responsible for conformity with any standards, codes, or regulations that apply to the combination of products in the customer's application or use of the products.

At the customer's request, OMRON will provide applicable third party certification documents identifying ratings and limitations of use that apply to the products. This information by itself is not sufficient for a complete determination of the suitability of the products in combination with the end product, machine, system, or other application or use.

The following are some examples of applications for which particular attention must be given. This is not intended to be an exhaustive list of all possible uses of the products, nor is it intended to imply that the uses listed may be suitable for the products:

- Outdoor use, uses involving potential chemical contamination or electrical interference, or conditions or uses not described in this manual.
- Nuclear energy control systems, combustion systems, railroad systems, aviation systems, medical equipment, amusement machines, vehicles, safety equipment, and installations subject to separate industry or government regulations.
- Systems, machines, and equipment that could present a risk to life or property.

Please know and observe all prohibitions of use applicable to the products.

NEVER USE THE PRODUCTS FOR AN APPLICATION INVOLVING SERIOUS RISK TO LIFE OR PROPERTY WITHOUT ENSURING THAT THE SYSTEM AS A WHOLE HAS BEEN DESIGNED TO ADDRESS THE RISKS, AND THAT THE OMRON PRODUCTS ARE PROPERLY RATED AND INSTALLED FOR THE INTENDED USE WITHIN THE OVERALL EQUIPMENT OR SYSTEM.

PROGRAMMABLE PRODUCTS

OMRON shall not be responsible for the user's programming of a programmable product, or any consequence thereof.

Disclaimers

CHANGE IN SPECIFICATIONS

Product specifications and accessories may be changed at any time based on improvements and other reasons.

It is our practice to change model numbers when published ratings or features are changed, or when significant construction changes are made. However, some specifications of the products may be changed without any notice. When in doubt, special model numbers may be assigned to fix or establish key specifications for your application on your request. Please consult with your OMRON representative at any time to confirm actual specifications of purchased products.

DIMENSIONS AND WEIGHTS

Dimensions and weights are nominal and are not to be used for manufacturing purposes, even when tolerances are shown.

PERFORMANCE DATA

Performance data given in this manual is provided as a guide for the user in determining suitability and does not constitute a warranty. It may represent the result of OMRON's test conditions, and the users must correlate it to actual application requirements. Actual performance is subject to the OMRON Warranty and Limitations of Liability.

ERRORS AND OMISSIONS

The information in this manual has been carefully checked and is believed to be accurate; however, no responsibility is assumed for clerical, typographical, or proofreading errors, or omissions.

Table of Contents

Chapter 1. Introduction	1-1
1-1 Features	1-2
1-2 System Configuration	1-7
1-3 Servo Driver Nomenclature	1-9
1-4 Applicable Standards and Models	1-10
1-5 System Block Diagrams	1-11
Chapter 2. Standard Models and Specifications	2-1
2-1 Standard Models	2-2
2-2 Servo Driver and Servomotor Combinations	2-22
2-3 External and Mounted Dimensions	2-24
2-3-1 AC Servo Drivers	2-24
2-3-2 Parameter Units	2-32
2-3-3 AC Servomotors	2-33
2-3-4 AC Servomotors with Gears	2-49
2-4 Servo Driver Specifications	2-62
2-4-1 General Specifications	2-62
2-4-2 Performance Specifications	2-63
2-4-3 Terminal Block Specifications	2-67
2-4-4 Control I/O Specifications (CN1)	2-68
2-4-5 Encoder Input Specifications (CN2)	2-89
2-4-6 Parameter Unit Input Specifications (CN3)	2-90
2-4-7 Monitor Output Connector Specifications (CN5)	2-90
2-4-8 Battery Connector Specifications (CN8)	2-91
2-5 Servomotor Specifications	2-92
2-5-1 General Specifications	2-93
2-5-2 Performance Specifications	2-95
2-5-3 Specifications for Servomotors with Reduction Gears	2-114
2-5-4 Encoder Specifications	2-119
2-6 Cable and Connector Specifications	2-120
2-6-1 Control Cables	2-120
2-6-2 Motor Cable Specifications	2-131
2-6-3 Peripheral Cables and Connector Specifications	2-152
2-7 Servo Relay Units and Cable Specifications	2-156
2-7-1 Servo Relay Units	2-156
2-7-2 Cable for Servo Relay Units	2-159
2-8 Parameter Unit and Cable Specifications	2-177
2-8-1 Parameter Unit	2-177
2-8-2 Parameter Unit Cable (R88A-CCW002C)	2-178
2-9 External Regeneration Resistors/Resistance Units	2-180
2-10 Absolute Encoder Backup Battery Specifications	2-182
2-11 DC Reactors	2-184
Chapter 3. System Design and Installation	3-1
3-1 Installation Conditions	3-3
3-1-1 Servo Drivers	3-3
3-1-2 Servomotors	3-4
3-2 Wiring	3-9
3-2-1 Connecting Cable	3-9
3-2-2 Peripheral Device Connection Examples	3-15

Table of Contents

3-2-3	Terminal Block Wiring	3-17
3-2-4	Wiring for Noise Resistance	3-21
3-2-5	Wiring for Conformity to EMC Directives	3-28
3-3	Regenerative Energy Absorption	3-38
3-3-1	Regenerative Energy Calculation	3-38
3-3-2	Servo Driver Regenerative Energy Absorption Capacity	3-40
3-3-3	Regenerative Energy Absorption by External Regeneration Resistance	3-41
3-4	Adjustments and Dynamic Braking When Load Inertia Is Large	3-45
3-4-1	Adjustments When Load Inertia Is Large	3-45
3-4-2	Dynamic Braking When Load Inertia Is Large	3-45

Chapter 4. Operation **4-1**

4-1	Operational Procedure	4-3
4-2	Preparing for Operation	4-4
4-2-1	Turning Power ON and Checking Indicators	4-4
4-2-2	Absolute Encoder Setup and Battery Changes	4-6
4-3	Trial Operation	4-8
4-3-1	Operation Details	4-8
4-3-2	Jog Operation	4-12
4-4	User Parameters	4-16
4-4-1	Setting and Checking Parameters	4-16
4-4-2	Parameter Tables	4-18
4-4-3	Important Parameters	4-32
4-4-4	Parameter Details	4-43
4-5	Operation Functions	4-73
4-5-1	Position Control (Position)	4-73
4-5-2	Speed Control (Speed)	4-74
4-5-3	Torque Control (Torque)	4-76
4-5-4	Internally-set Speed Control	4-77
4-5-5	Switching the Control Mode (Switching Control)	4-82
4-5-6	Forward and Reverse Drive Prohibit (All Operating Modes)	4-85
4-5-7	Encoder Dividing Function (All Operating Modes)	4-87
4-5-8	Brake Interlock (All Operating Modes)	4-88
4-5-9	Gain Reduction (Position, Speed, Internally-set speed Control)	4-90
4-5-10	Torque Limit Function (All Operating Modes)	4-91
4-5-11	Soft Start Function (Speed, Internally-set Speed Control)	4-93
4-5-12	Electronic Gear Function (Position)	4-94
4-5-13	Position Command Filter Function (Position)	4-95
4-5-14	Position Lock Function (Speed, Internally-set Speed Control)	4-97
4-5-15	Speed Limit Function (Torque)	4-98
4-6	Trial Operation Procedure	4-99
4-7	Making Adjustments	4-101
4-7-1	Online Auto-tuning	4-101
4-7-2	Manual Tuning	4-104
4-8	Advanced Adjustment Functions	4-109
4-8-1	Bias Function (Position)	4-109
4-8-2	Feed-forward Function (Position)	4-110
4-8-3	Torque Feed-forward Function (Speed)	4-110
4-8-4	Speed Feed-forward Function (Position)	4-112
4-8-5	Gain Switching (Position, Speed, Internally-set Speed Control)	4-113
4-8-6	Automatic Gain Switching (Position Control)	4-114
4-8-7	Notch Filter (Position, Speed, Internally-set Speed Control)	4-115

Table of Contents

4-8-8	Speed Feedback Compensation (Position, Speed, Internally-set Time Control)	4-117
4-8-9	Speed Feedback Filter (Position, Speed, Internally-set Speed Control)	4-118
4-8-10	P Control Switching (Position, Speed, Internally-set Speed Control)	4-118
4-9	Using Displays	4-120
4-9-1	Power Supply Indicator and Charge Indicator	4-121
4-9-2	Status Display Mode	4-121
4-9-3	Monitor Mode (Unjjj)	4-123
4-10	Using Monitor Output	4-127
4-11	System Check Mode	4-130
4-11-1	Alarm History	4-131
4-11-2	Online Auto-tuning Functions	4-133
4-11-3	Servomotor Origin Search	4-135
4-11-4	User Parameter Initialization	4-137
4-11-5	Command Offset Adjustment	4-138
4-11-6	Analog Monitor Output Adjustment	4-142
4-11-7	Servomotor Current Detection Offset Adjustment	4-145
4-11-8	Password Setting	4-149
4-11-9	Checking Servomotor Parameters	4-150
4-11-10	Checking the Version	4-152
4-11-11	Changing Absolute Encoder Rotation Setting (ABS)	4-153
4-11-12	Clearing Option Unit Detection Results	4-154

Chapter 5. Troubleshooting **5-1**

5-1	Measures when Trouble Occurs	5-2
5-1-1	Preventive Checks Before Trouble Occurs	5-2
5-1-2	Precautions	5-3
5-1-3	Replacing the Servomotor and Servo Driver	5-3
5-2	Alarms	5-5
5-3	Troubleshooting	5-9
5-3-1	Error Diagnosis Using Alarm Display	5-9
5-3-2	Troubleshooting by Means of Operating Status	5-18
5-4	Overload Characteristics (Electron Thermal Characteristics)	5-20
5-5	Periodic Maintenance	5-21
5-6	Replacing the Absolute Encoder Battery (ABS)	5-23

Chapter 6. Appendix **6-1**

6-1	Connection Examples	6-2
6-2	Encoder Dividing Rate for Servo Controllers	6-13
6-3	Single-phase Power for 3,000-r/min (750-W) Servomotors	6-14
6-4	Parameter Setting Tables	6-15
6-5	Alarms and Warnings when a JUSP-NS115 MECHATROLINK-II Option Unit is Mounted	6-28

Revision History **R-1**

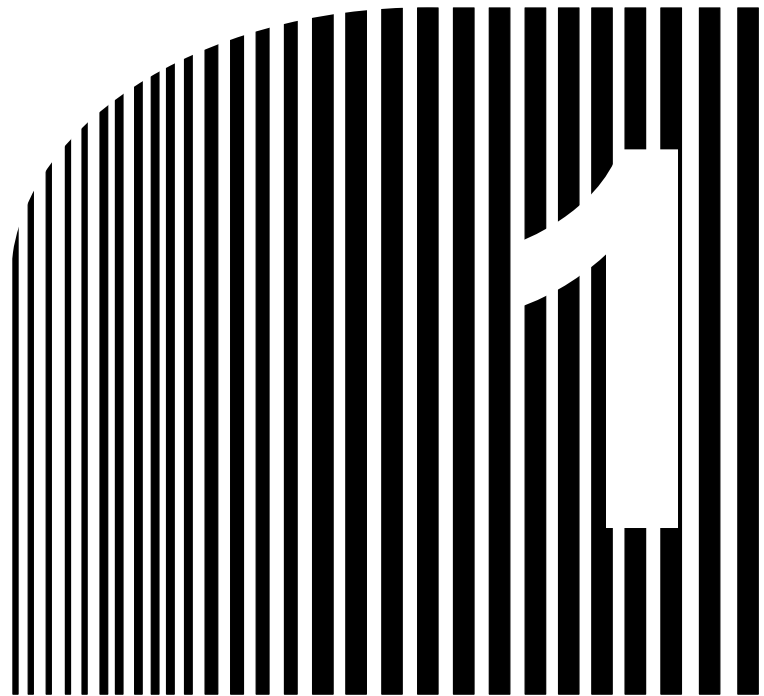

Chapter 1

• Introduction •

- 1-1 Features
- 1-2 System Configuration
- 1-3 Servo Driver Nomenclature
- 1-4 Applicable Standards and Models
- 1-5 System Block Diagrams

1-1 Features

With their superior performance and fast response, plus a wider selection of models, the OMNUC W-series AC Servomotors and Servo Drivers inherit the features of and surpass the previous OMNUC U Series.

■ Faster Response and Rotation Speed

The W-series AC Servomotors and Servo Drivers provide faster response than the previous U-series models, with high-frequency responses of 400 Hz (compared to 250 Hz for the U Series). Moreover, the 3,000-r/min Servomotors provide rotation speeds of up to 5,000 r/min, as compared to 4,500 r/min for the U Series, for even faster positioning.

■ Wider Selection

In addition to 3,000-r/min (30-W to 5-kW) Servomotors, the W-series product line offers 1,000-r/min (300-W to 5.5-kW) models and 1,500-r/min (450-W to 15-kW) models to choose from. They are ideal for applications requiring high torque. Included among the 3,000-r/min models are Flat-style (100-W to 1.5-kW) Servomotors that are ideal for applications requiring installation in tight spaces.

■ IP67 (Waterproof) Servomotors

The 3,000-r/min (1- to 5-kW), 1,000 r/min (300 W to 5.5 kW), and 1,500 r/min (450 W to 15 kW) Servomotors have an enclosure rating of IP67 (waterproof, except for through-shaft parts). The 3,000-r/min (100 W to 1.5-kW) Flat-style Servomotors are also available with IP67 enclosure ratings that include waterproofing for through-shaft parts. Therefore, the W-series Servomotors can be used even in places where they may be exposed to water. (The standard cables, however, cannot be used with IP67 models, and the appropriate cables must be provided by the user.)

■ Conformity to Standards

The W Series conforms to EC Directives (both low-voltage and EMC) as well as to UL and cUL, thereby assisting the user in meeting required standards.

■ Built-in Regenerative Power Processing

In addition to the built-in regenerative power processing function using regeneration resistance, external regeneration resistance can also be connected, allowing the W Series to be used for applications with high regenerative energy on vertical axis.

■ Harmonic Current Control Measures

Terminals for DC Reactor connections are provided to assist with harmonic current control.

■ Online Autotuning

Autotuning is possible during normal operation with no need to switch to a special autotuning mode, making it easy to set the gain correctly.

■ Gain Changes

There are two types of gain settings, and the gain can be changed when the load changes during operation.

■ Control Functions

Any one of the following 12 control modes can be selected in the parameter settings, thereby allowing various applications with a single Servo Driver.

Control mode		
Speed control (analog commands)		
Position control (pulse train commands)		[Default setting]
Torque control (analog commands)		
Internal speed control settings		
Internal speed control settings	↔	Speed control (analog commands)
Internal speed control settings	↔	Position control (pulse train commands)
Internal speed control settings	↔	Torque control (analog commands)
Position control (pulse train commands)	↔	Speed control (analog commands)
Position control (pulse train commands)	↔	Torque control (analog commands)
Speed control (analog commands)	↔	Torque control (analog commands)
Speed control (analog commands) with position-lock stop		
Position control (pulse train commands) with pulse prohibit		

■ Password

A password can be required in order to make parameter changes.

■ Parameter Initialization

Parameters can be returned to their default settings.

■ Monitoring

The Servo Driver's operating status is displayed. The following items can be monitored: Speed feedback, speed commands, torque commands, number of pulses from the origin, electrical angle, I/O signals, command pulse speed, position deviation, motor load rate, regenerative load rate, dynamic resistance load rate, input pulse counter, and feedback pulse counter.

■ Jogging

The Servomotor can be set for either forward or reverse rotation, and the rotation speed can be set in the parameters.

■ Servomotor Origin Search

The origin search function can be used to find the Servomotor's origin (Z phase).

■ Automatic Adjustment of Command Offsets (Speed and Torque Control)

The offsets of the speed command input and torque command input can be adjusted automatically.

■ Monitor Output

The offset and scaling of the analog monitor outputs can be adjusted.

■ Multi-turn Limit Changes

The multi-turn limits for absolute encoders can be changed.

■ Electronic Gear (Position Control)

This function turns the Servomotor by the number of pulses obtained by applying the gear ratio to the number of command pulses. It can be effectively used in the following situations.

- When fine tuning positions and speeds while synchronizing two lines.
- When using a controller with a short command pulse frequency.
- When setting the mechanical movement per pulse to amounts such as 0.01 mm.

The electronic gear ratio is set in parameters (numerator: G1; denominator: G2). The setting range for G1 and G2 is 1 to 65,535, with $0.01 \leq (G1/G2) \leq 100$.

■ Encoder Dividing Function

The encoder signal output from the Servo Driver can be set to the desired number of pulses.

■ Soft Start Function (Speed Control, Internally Set Speed Control Settings)

This function causes the Servomotor to be started and stopped at the preset acceleration/deceleration times, allowing a simple position control system to be constructed without a Positioner or Host Controller.

The acceleration and deceleration times are set separately, and the setting range is 0 to 10 s for each.

■ Position Acceleration/Deceleration Function

Applying acceleration and deceleration to command pulses enables smooth tracking of commands for rapid startups. Either primary delay or linear acceleration/decelerations can be selected for positioning.

■ Warning Output

Overload and regeneration overload warnings are output. When a warning is output, taking measures, such as shortening the operation cycle, can prevent an alarm from being generated.

■ Positioning Completed Output

The positioning completed range can be set in two stages, allowing peripheral device operations to begin sooner.

■ Reverse Mode

Forward and reverse commands can be switched in the parameters, without changing the wiring to the Servomotor or encoder.

■ Brake Interlock Output

Timing signals interlocked with the Servomotor's ON/OFF status and rotational speed are output, so the holding brakes of Servomotors with brakes can be operated reliably.

■ Output Signal Selection

Any three output signals can be selected for output from among the following: Positioning completed 1/2, speed conformity, Servomotor rotation detection, servo preparation completed, current limit detection, speed limit detection, brake interlock, overload warning, and warning output signals. It is also possible to allocate multiple outputs to the same pin number. For example, the positioning completed 1 signal and the speed conformity signal could both be allocated to pin number 1.

■ Overtravel Sequence

An overtravel sequence suitable for the system can be selected. There are three deceleration methods available: Dynamic brake deceleration, free-run deceleration, and emergency-stop torque deceleration (parameter setting).

■ Feed-forward Function and Bias (Position Control)

These functions reduce the position control time.

• Feed-forward Function

Reduces the position control time by reducing the number of pulses accumulated in the deviation counter.

• Bias

Reduces the positioning time by adding the bias revolutions to the speed command when the deviation counter value exceeds the bias addition range.

■ Computer Monitoring

The special Servo Driver Communications Software enables performing parameter setting, speed and current monitoring, speed and current waveform displays, I/O monitoring, autotuning, jogging, and other operations from a computer. It is also possible to perform multiple-axis communications that set the parameters and monitor operations for multiple Servo Drivers. For details, refer to user documentation on the Servo Driver Communications Software.

■ DeviceNet Option Unit

A Servo Driver can function as a slave on a DeviceNet network if a DeviceNet Option Unit (R88A-NCW152-DRT) is mounted to it, enabling application of the Servo Driver as a network driver. Commands can be sent via DeviceNet communications to the DeviceNet Option Unit to produce outputs to the driver. Outputting positioning commands to the driver through the option unit connector enables positioning operations without a controller. Refer to the *OMNUC W-series DeviceNet Option Unit User's Manual* (Cat. No. I538) for details.

Note The DeviceNet Option Unit is supported by W-series Servo Drivers with a software version of r.0014 or later. Refer to *4-11-10 Checking the Version* for methods of confirming the Servo Driver software version.

■ MECHATROLINK-II Compatibility

The Servo Driver can be incorporated as a Slave in a MECHATROLINK network by installing the Yaskawa JUSP-NS115 MECHATROLINK-II Option Unit (OMRON model number: FNY-NS115) on the Servo Driver. This enables the Servo Driver to be used as a network Servo Driver.

A wide range of motion control can be achieved in a MECHATROLINK-II network from the Motion Control Unit.

For details, refer to the *SYSMAC CS-series CS1W-MCH71 Motion Control Unit Operation Manual* (Cat. No. W426) and the *JUSP-NS115 MECHATROLINK-II Application Module Operation Manual* (This manual can be obtained from a Yaskawa Electric sales representative or downloaded from the OMRON website).

Note The MECHATROLINK-II Option Unit is compatible with a W-series Servo Driver with software version r.0039 or later and MECHATROLINK-II Option Unit with software version VER.***03 (on the nameplate on the side of the Unit). Refer to *4-11-10 Checking the Version* for methods of confirming the Servo Driver software version.

1-2 System Configuration

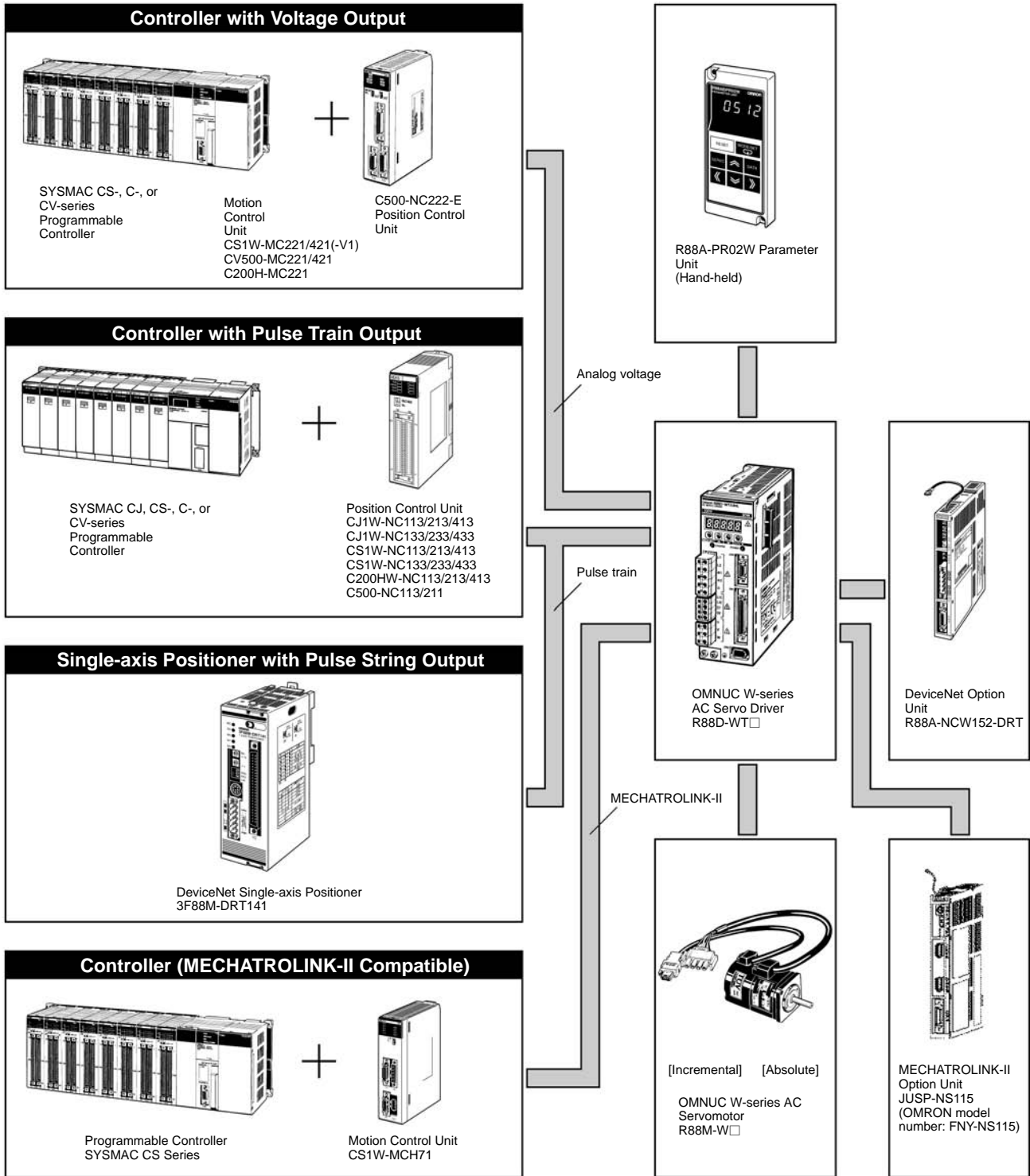

Note 1. Servomotors with absolute encoders can be used in combination with CS1W-MC221/421(-V1), CV500-MC221/421, C200H-MC221, or CS1W-MCH71 Motion Control Units, with the 3F88M-DRT141 DeviceNet Single-axis Positioner, or with the R88A-NCW152-DRT DeviceNet Option Unit.

- Note 2.** The DeviceNet Option Unit is supported by W-series Servo Drivers with a software version of r.0014 or later.
- Note 3.** The MECHATROLINK-II Option Unit is supported when using MECHATROLINK-II Option Unit software version VER.**03 (indicated on the nameplate on the side of the Unit) in combination with a W-series Servo Driver with software version r.0039 or later. Refer to *4-11-10 Checking the Version* for methods of confirming the Servo Driver software version.

1-3 Servo Driver Nomenclature

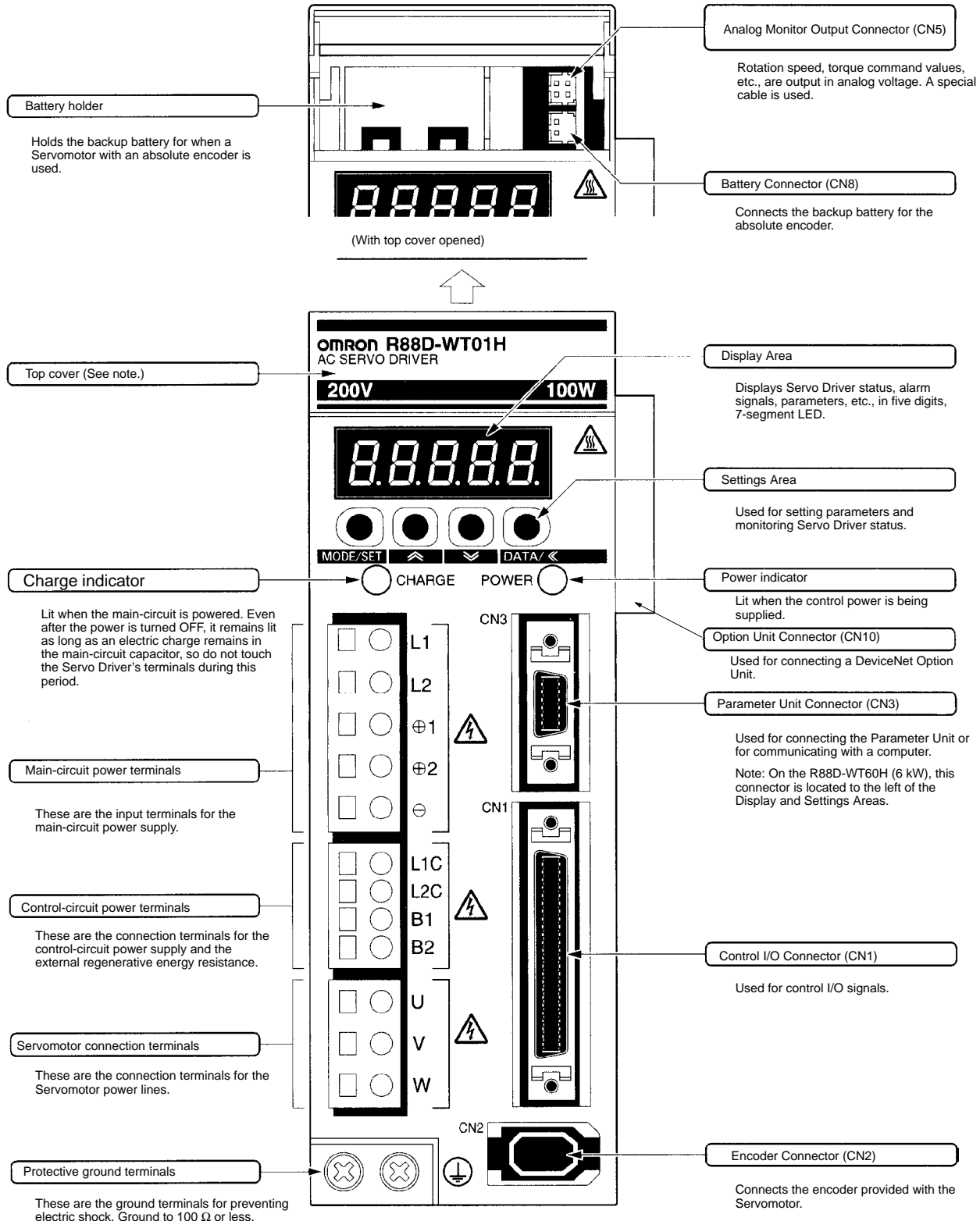

Note The R88D-WT60H to R88D-WT150H models do not have a top cover. The Analog Monitor Output Connector (CN5), the Battery Connector (CN8), and the battery holder are all located to the right of the display and operation areas. Also, the Terminal Block (for the control circuit, main circuit, and Servomotor) is mounted to the bottom of the Servo Driver.

1-4 Applicable Standards and Models

■ EC Directives

EC Directive	Product	Applicable standard	Remarks
Low voltage	AC Servo Drivers	EN50178	Safety requirements for electrical equipment for measurement, control, and laboratory use.
	AC Servomotors	IEC60034-8 EN60034-1, -5, -9	Rotating electrical machines.
EMC	AC Servo Drivers and AC Servomotors	EN55011 class A group 1	Limits and methods for measuring radio disturbance characteristics of industrial, scientific, and medical (ISM) radio-frequency equipment.
		EN61000-6-2	Electromagnetic compatibility generic immunity standard in industrial environments

Note Installation under the conditions specified in *3-2-5 Wiring Conditions Satisfying EMC Directives* is required to conform to EMC Directives.

■ UL/cUL Standards

Standards	Product	Applicable standard	File No.	Remarks
UL	AC Servo Drivers	UL508C	E179149	Power conversion equipment
	AC Servomotors	UL1004	E179189	Electric motors
cUL	AC Servo Drivers	cUL C22.2 No. 14	E179149	Industrial control equipment
	AC Servomotors	cUL C22.2 No. 100	E179189	Motors and generators

1-5 System Block Diagrams

- 200 V AC: R88D-WTA3H/-WTA5H/-WT01H/-WT02H/-WT04H
- 100 V AC: R88D-WTA3HL/-WTA5HL/-WT01HL/-WT02HL

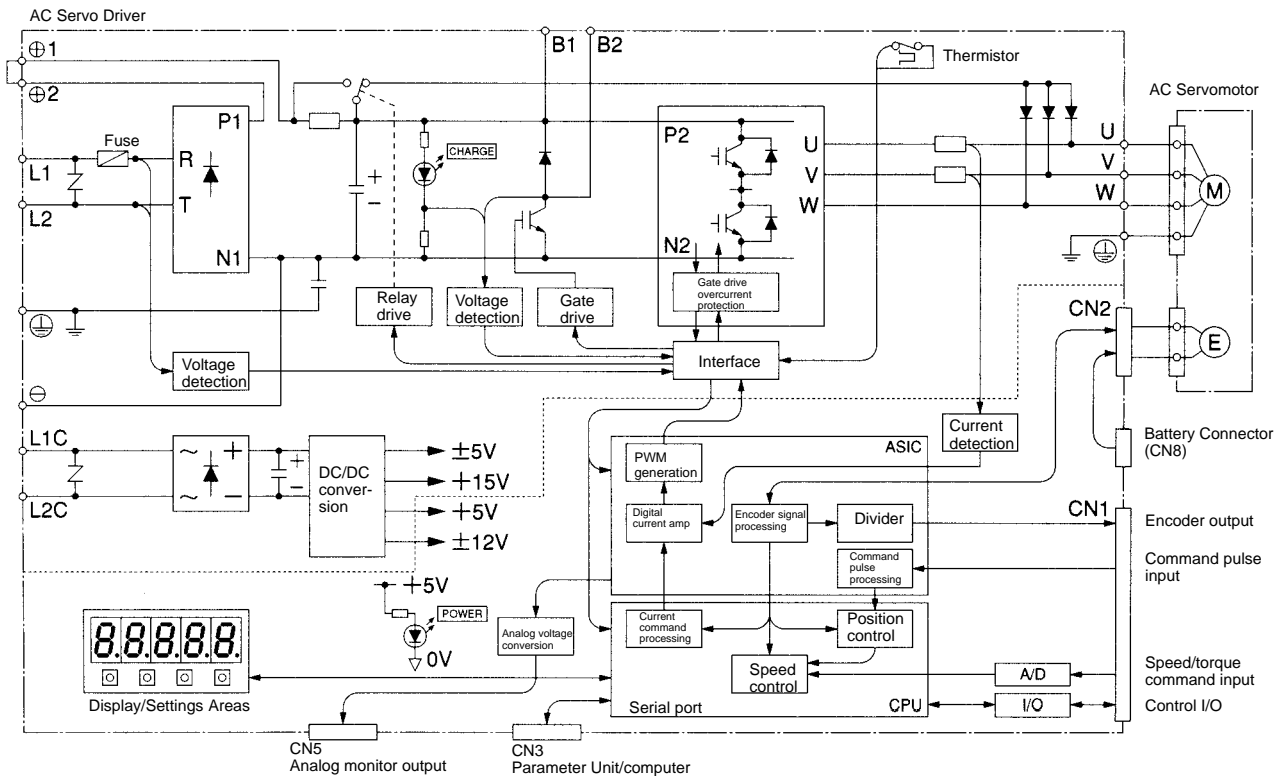

■ 200 V AC: R88D-WT05H/-WT08H/-WT10H/-WT15H

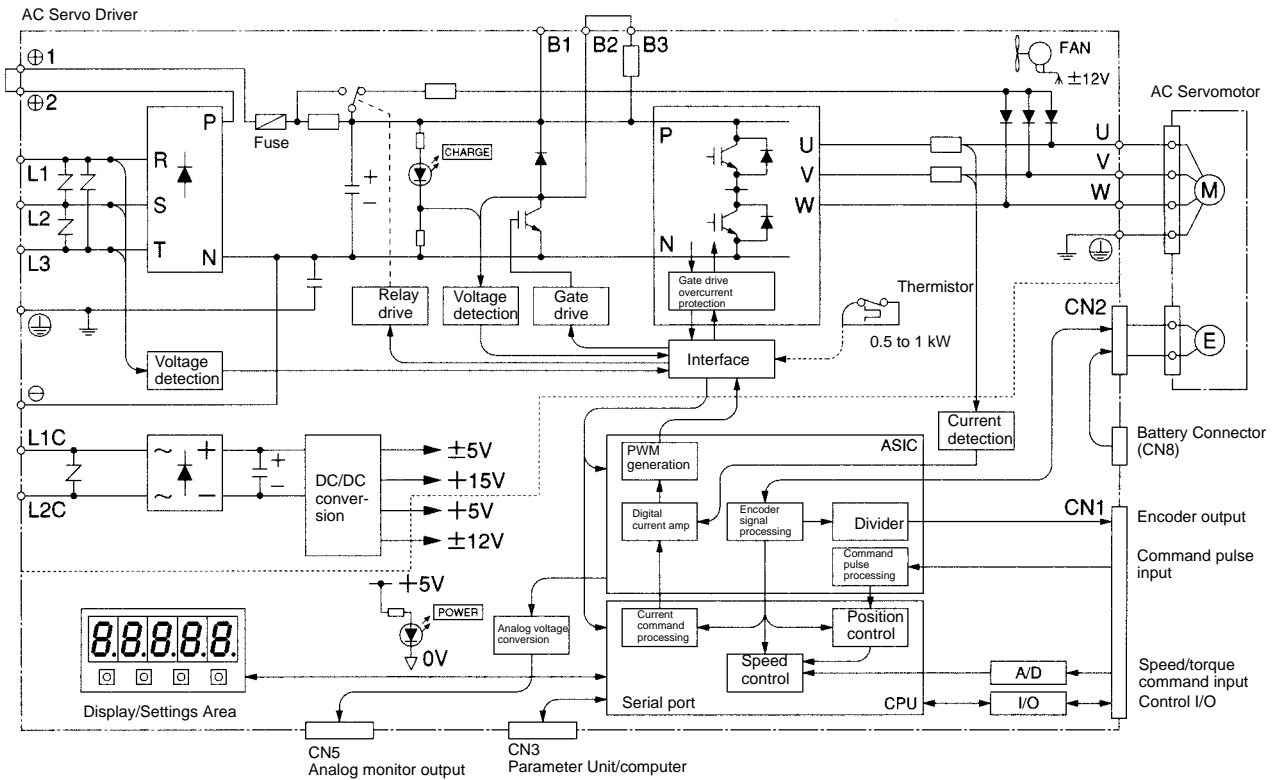

■ 200 V AC: R88D-WT20H/-WT30H/-WT50H

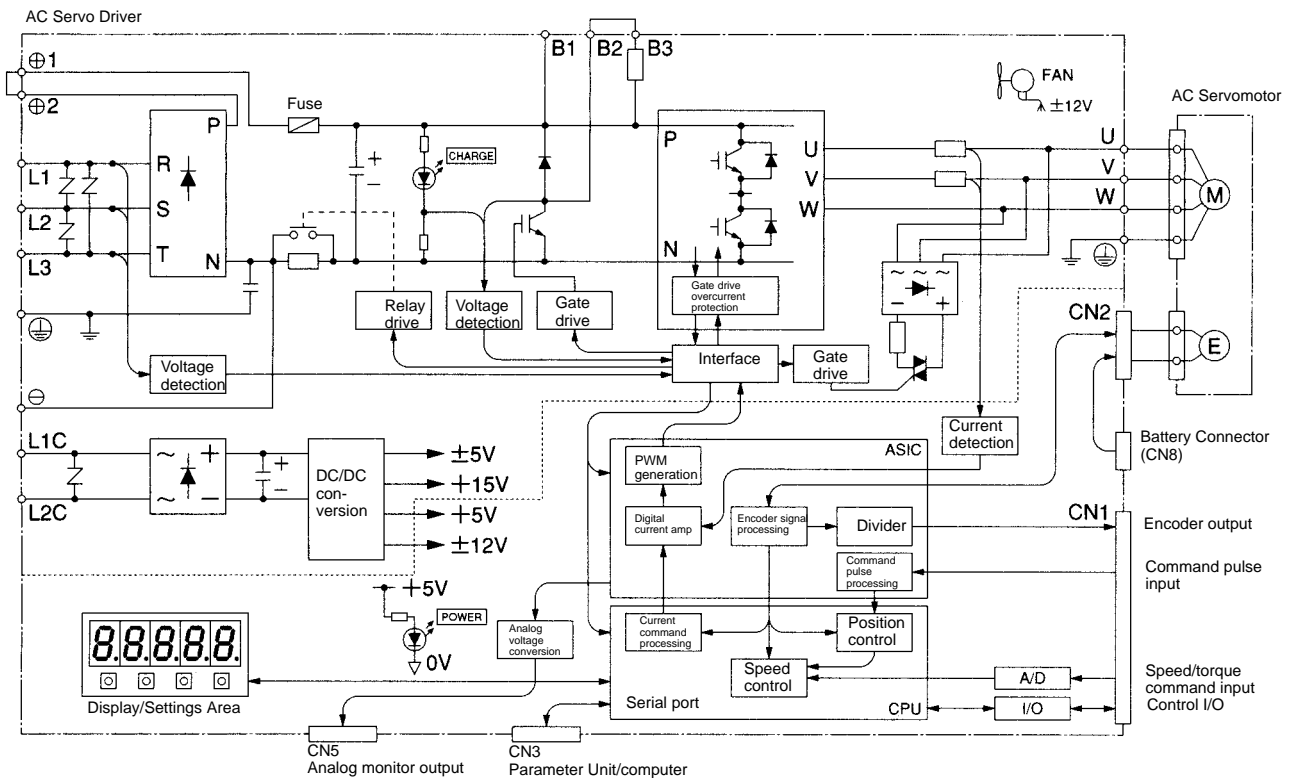

■ 200 V AC: R88D-WT60H/-WT75H/-WT150H

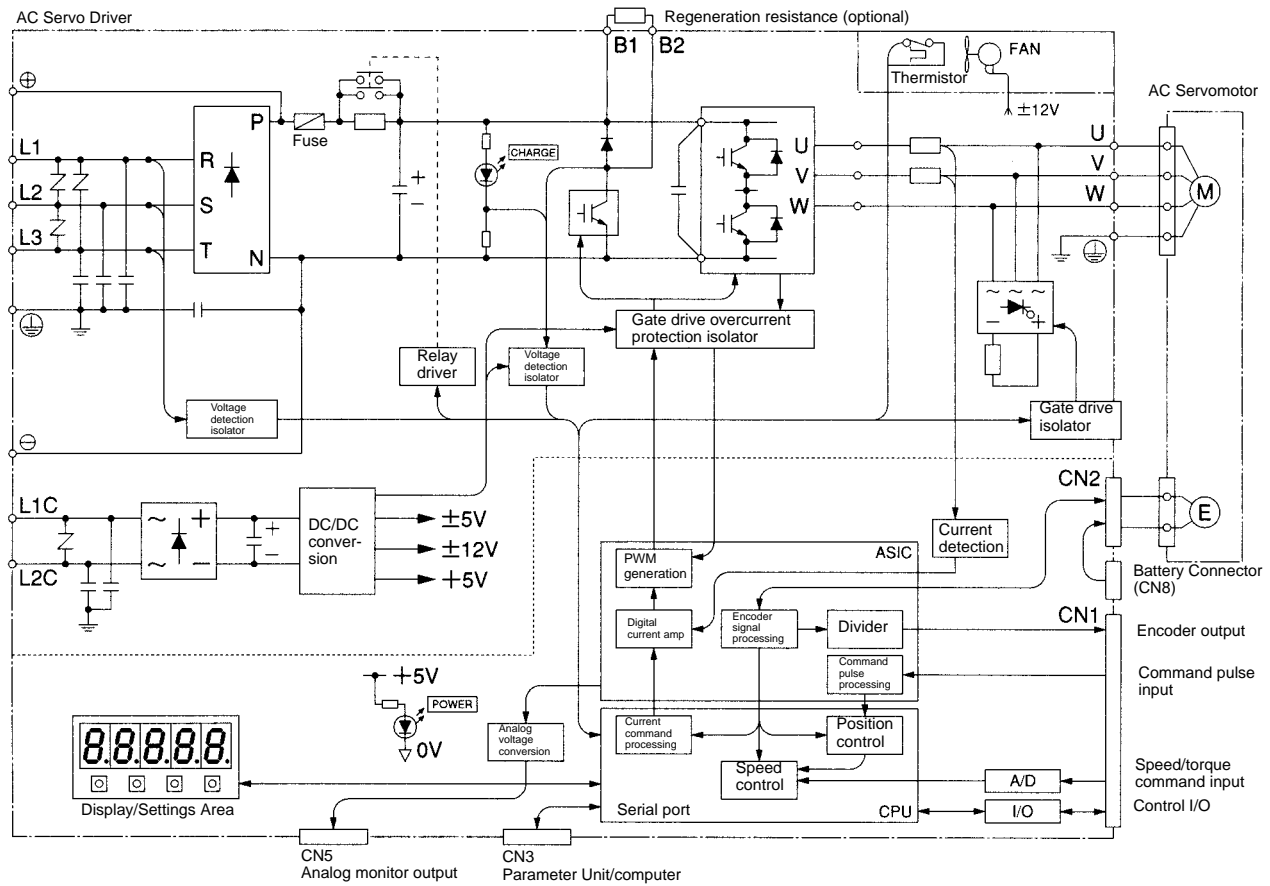

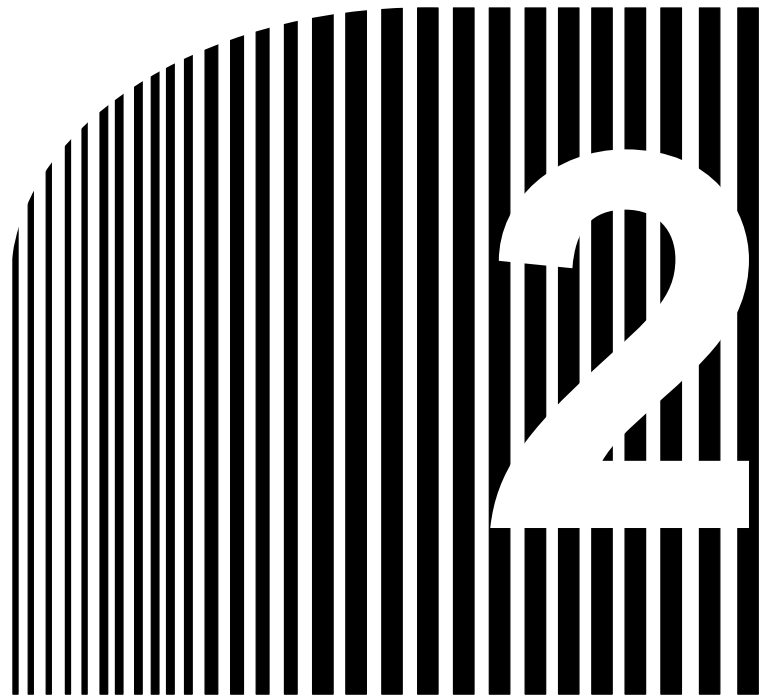

Chapter 2

• **Standard Models and Specifications** •

- 2-1 Standard Models
- 2-2 Servo Driver and Servomotor Combinations
- 2-3 External and Mounted Dimensions
- 2-4 Servo Driver Specifications
- 2-5 Servomotor Specifications
- 2-6 Cable and Connector Specifications
- 2-7 Servo Relay Units and Cable Specifications
- 2-8 Parameter Unit and Cable Specifications
- 2-9 External Regeneration Resistors/Resistance Units
- 2-10 Absolute Encoder Backup Battery Specifications
- 2-11 DC Reactors

2-1 Standard Models

■ Servo Drivers

Specifications		Model
Single-phase 100 V AC	30 W	R88D-WTA3HL
	50 W	R88D-WTA5HL
	100 W	R88D-WT01HL
	200 W	R88D-WT02HL
Single-phase 200 V AC	30 W	R88D-WTA3H
	50 W	R88D-WTA5H
	100 W	R88D-WT01H
	200 W	R88D-WT02H
	400 W	R88D-WT04H
Three-phase 200 V AC	500 W	R88D-WT05H
	750 W	R88D-WT08H
	1 kW	R88D-WT10H
	1.5 kW	R88D-WT15H
	2 kW	R88D-WT20H
	3 kW	R88D-WT30H
	5 kW	R88D-WT50H
	6 kW	R88D-WT60H
	7.5 kW	R88D-WT75H
15 kW	R88D-WT150H	

■ Control Cable

Specifications		Model
Motion Control Unit Cable (1 axis)	1 m	R88A-CPW001M1
	2 m	R88A-CPW002M1
	3 m	R88A-CPW003M1
	5 m	R88A-CPW005M1
Motion Control Unit Cable (2 axes)	1 m	R88A-CPW001M2
	2 m	R88A-CPW002M2
	3 m	R88A-CPW003M2
	5 m	R88A-CPW005M2
General Control Cable (with connector on one end)	1 m	R88A-CPW001S
	2 m	R88A-CPW002S
Connector Terminal Block Cable	1 m	R88A-CTW001N
	2 m	R88A-CTW002N
Connector Terminal Block		XW2B-50G5

Note Connector Terminal Block Cable is required when a Connector Terminal Block is used.

■ Peripheral Cables and Connectors

Specifications		Model
Analog Monitor Cable (CN5)	1 m	R88A-CMW001S
Computer Monitor Cable (CN3)	DOS 2 m	R88A-CCW002P2
Control I/O Connector (CN1)		R88A-CNU11C
Encoder Connector (CN2)		R88A-CNW01R
Encoder Connector for Motor End		R88A-CNW02R

Note Computer Monitor Cable and OMNUC W-series Personal Computer Monitor Software for Servo Drivers (Windows-based) are required when a personal computer is used for setting Servo Driver parameters and for monitoring.

■ Servo Relay Units

Specifications		Model
Servo Relay Unit	For CJ1W-NC113/133 For CS1W-NC113/133 For C200HW-NC113 For 3F88M-DRT141	XW2B-20J6-1B
	For CJ1W-NC213/233/413/433 For CS1W-NC213/233/413/433 For C500-NC113/211 For C200HW-NC213/413	XW2B-40J6-2B
	For CQM1H-PLB21 For CQM1-CPU43-EV1 For CS1W-HCP22-V1	XW2B-20J6-3B
Servo Driver Cable	1 m	XW2Z-100J-B4
	2 m	XW2Z-200J-B4
Position Control Unit Cable	For C500-NC113/211	0.5 m XW2Z-050J-A2 1 m XW2Z-100J-A2
	For CQM1-CPU43-EV1 For CQM1H-PLB21	0.5 m XW2Z-050J-A3 1 m XW2Z-100J-A3
	For CS1W-NC113 For C200HW-NC113	0.5 m XW2Z-050J-A6 1 m XW2Z-100J-A6
	For CS1W-NC213/413 For C200HW-NC213/413	0.5 m XW2Z-050J-A7 1 m XW2Z-100J-A7
	For CS1W-NC133	0.5 m XW2Z-050J-A10 1 m XW2Z-100J-A10
	For CS1W-NC233	0.5 m XW2Z-050J-A11 1 m XW2Z-100J-A11
	For CJ1W-NC113	0.5 m XW2Z-050J-A14 1 m XW2Z-100J-A14
	For CJ1W-NC213/413	0.5 m XW2Z-050J-A15 1 m XW2Z-100J-A15
	For CJ1W-NC133	0.5 m XW2Z-050J-A18 1 m XW2Z-100J-A18
	For CJ1W-NC233/433	0.5 m XW2Z-050J-A19 1 m XW2Z-100J-A19
	For CS1W-HCP22-V1, 1-axis	0.5 m XW2Z-050J-A22 1 m XW2Z-100J-A22
	For CS1W-HCP22-V1, 2-axis	0.5 m XW2Z-050J-A23 1 m XW2Z-100J-A23
	For 3F88M-DRT141	0.5 m XW2Z-050J-A24 1 m XW2Z-100J-A24

■ Option Units

Specifications	Model
DeviceNet Option Unit	R88A-NCW152-DRT

Note A DeviceNet Option Unit is required to set Servo Driver parameters or perform positioning via a DeviceNet network. Refer to the *OMNUC W-series DeviceNet Option Unit User's Manual* (Cat. No. I538) for details.

■ Parameter Units

Specifications	Model
Hand-held (with 1-m cable)	R88A-PR02W
Parameter Unit Cable (2 m)	R88A-CCW002C

Note 1. A Parameter Unit is required for operating and monitoring the Servo Driver at a remote location or with a control panel.

Note 2. If the 1-m cable provided with the Parameter Unit is not long enough, purchase the 2-m Parameter Unit Cable and use it in place of the 1-m cable.

■ External Regeneration Resistors/Units

Specifications		Model
Resistor	220 W 47 Ω	R88A-RR22047S
Resistance Unit	880 W 6.25 Ω	R88A-RR88006

Note Required when the motor's regenerative energy is too high.

■ Absolute Encoder Backup Battery

Specifications	Model
1,000 mA·h, 3.6 V (for all Servo Drivers except the R88D-WT60H)	R88A-BAT01W
1,000 mA·h, 3.6 V (for the R88D-WT60H/75H/150H)	R88A-BAT02W

Note Required when using a Servomotor with an absolute encoder. The cable and connector are included.

■ DC Reactors

Specifications	Model
For R88D-WTA3HL/A5HL/01HL	R88A-PX5063
For R88D-WT02HL	R88A-PX5062
For R88D-WTA3H/A5H/01H	R88A-PX5071
For R88D-WT02H	R88A-PX5070
For R88D-WT04H	R88A-PX5069
For R88D-WT05H/08H/10H	R88A-PX5061
For R88D-WT15H/20H	R88A-PX5060
For R88D-WT30H	R88A-PX5059
For R88D-WT50H	R88A-PX5068

Note There is no DC Reactor for the R88D-WT60H/75H/150H.

■ Front-panel Brackets

Specifications	Model
For R88D-WTA3HL to WT02HL	R88A-TK01W
For R88D-WTA3H to WT10H	R88A-TK01W
For R88D-WT15H	R88A-TK02W
For R88D-WT20H/30H/50H	R88A-TK03W

Note 1. Required when mounting a Servo Driver from the front panel.

Note 2. There are no front-panel brackets for the R88D-WT60H, R88D-WT75H or R88D-WT150H.

■ Encoder Cables (For Incremental or Absolute Encoders)

Specifications			Model
For 3,000-r/min Servomotors	30 to 750 W	3 m	R88A-CRWA003C
		5 m	R88A-CRWA005C
		10 m	R88A-CRWA010C
		15 m	R88A-CRWA015C
		20 m	R88A-CRWA020C
		30 m	R88A-CRWA030C
		40 m	R88A-CRWA040C
		50 m	R88A-CRWA050C
	1 to 5 kW	3 m	R88A-CRWB003N
		5 m	R88A-CRWB005N
		10 m	R88A-CRWB010N
		15 m	R88A-CRWB015N
		20 m	R88A-CRWB020N
		30 m	R88A-CRWB030N
		40 m	R88A-CRWB040N
		50 m	R88A-CRWB050N
		For 3,000-r/min Flat-style Servomotors	100 W to 1.5 kW
5 m	R88A-CRWA005C		
10 m	R88A-CRWA010C		
15 m	R88A-CRWA015C		
20 m	R88A-CRWA020C		
30 m	R88A-CRWA030C		
40 m	R88A-CRWA040C		
50 m	R88A-CRWA050C		
For 1,000-r/min Servomotors For 1,500-r/min Servomotors	300 W to 5.5 kW	3 m	R88A-CRWB003N
	450 W to 15 kW	5 m	R88A-CRWB005N
		10 m	R88A-CRWB010N
		15 m	R88A-CRWB015N
		20 m	R88A-CRWB020N
		30 m	R88A-CRWB030N
		40 m	R88A-CRWB040N
50 m	R88A-CRWB050N		

■ Power Cables

• Power Cable for 3,000-r/min Servomotors

Specifications		Model		
		Without brake	With brake	
30 to 750 W	3 m	R88A-CAWA003S	R88A-CAWA003B	
		R88A-CAWA005S	R88A-CAWA005B	
	5 m	R88A-CAWA010S	R88A-CAWA010B	
		R88A-CAWA015S	R88A-CAWA015B	
	10 m	R88A-CAWA020S	R88A-CAWA020B	
		R88A-CAWA030S	R88A-CAWA030B	
	15 m	R88A-CAWA040S	R88A-CAWA040B	
		R88A-CAWA050S	R88A-CAWA050B	
	1 to 2 kW	3 m	R88A-CAWC003S	R88A-CAWC003B
			R88A-CAWC005S	R88A-CAWC005B
5 m		R88A-CAWC010S	R88A-CAWC010B	
		R88A-CAWC015S	R88A-CAWC015B	
10 m		R88A-CAWC020S	R88A-CAWC020B	
		R88A-CAWC030S	R88A-CAWC030B	
15 m		R88A-CAWC040S	R88A-CAWC040B	
		R88A-CAWC050S	R88A-CAWC050B	
3 to 5 kW		3 m	R88A-CAWD003S	R88A-CAWD003B
			R88A-CAWD005S	R88A-CAWD005B
	5 m	R88A-CAWD010S	R88A-CAWD010B	
		R88A-CAWD015S	R88A-CAWD015B	
	10 m	R88A-CAWD020S	R88A-CAWD020B	
		R88A-CAWD030S	R88A-CAWD030B	
	15 m	R88A-CAWD040S	R88A-CAWD040B	
		R88A-CAWD050S	R88A-CAWD050B	
	20 m	R88A-CAWD030S	R88A-CAWD030B	
		R88A-CAWD040S	R88A-CAWD040B	
30 m	R88A-CAWD040S	R88A-CAWD040B		
	R88A-CAWD050S	R88A-CAWD050B		

• Power Cable for 3,000-r/min Flat-style Servomotors

Specifications		Model	
		Without brake	With brake
100 to 750 W	3 m	R88A-CAWA003S	R88A-CAWA003B
	5 m	R88A-CAWA005S	R88A-CAWA005B
	10 m	R88A-CAWA010S	R88A-CAWA010B
	15 m	R88A-CAWA015S	R88A-CAWA015B
	20 m	R88A-CAWA020S	R88A-CAWA020B
	30 m	R88A-CAWA030S	R88A-CAWA030B
	40 m	R88A-CAWA040S	R88A-CAWA040B
	50 m	R88A-CAWA050S	R88A-CAWA050B
1.5 kW	3 m	R88A-CAWB003S	R88A-CAWB003B
	5 m	R88A-CAWB005S	R88A-CAWB005B
	10 m	R88A-CAWB010S	R88A-CAWB010B
	15 m	R88A-CAWB015S	R88A-CAWB015B
	20 m	R88A-CAWB020S	R88A-CAWB020B
	30 m	R88A-CAWB030S	R88A-CAWB030B
	40 m	R88A-CAWB040S	R88A-CAWB040B
	50 m	R88A-CAWB050S	R88A-CAWB050B

• Power Cable for 1,000-r/min Servomotors

Specifications		Model	
		Without brake	With brake
300 to 900 W	3 m	R88A-CAWC003S	R88A-CAWC003B
	5 m	R88A-CAWC005S	R88A-CAWC005B
	10 m	R88A-CAWC010S	R88A-CAWC010B
	15 m	R88A-CAWC015S	R88A-CAWC015B
	20 m	R88A-CAWC020S	R88A-CAWC020B
	30 m	R88A-CAWC030S	R88A-CAWC030B
	40 m	R88A-CAWC040S	R88A-CAWC040B
	50 m	R88A-CAWC050S	R88A-CAWC050B
1.2 to 3 kW	3 m	R88A-CAWD003S	R88A-CAWD003B
	5 m	R88A-CAWD005S	R88A-CAWD005B
	10 m	R88A-CAWD010S	R88A-CAWD010B
	15 m	R88A-CAWD015S	R88A-CAWD015B
	20 m	R88A-CAWD020S	R88A-CAWD020B
	30 m	R88A-CAWD030S	R88A-CAWD030B
	40 m	R88A-CAWD040S	R88A-CAWD040B
	50 m	R88A-CAWD050S	R88A-CAWD050B
4 kW (See note.)	3 m	R88A-CAWE003S	R88A-CAWE003B
	5 m	R88A-CAWE005S	R88A-CAWE005B
	10 m	R88A-CAWE010S	R88A-CAWE010B
	15 m	R88A-CAWE015S	R88A-CAWE015B
	20 m	R88A-CAWE020S	R88A-CAWE020B
	30 m	R88A-CAWE030S	R88A-CAWE030B
	40 m	R88A-CAWE040S	R88A-CAWE040B
	50 m	R88A-CAWE050S	R88A-CAWE050B
5.5 kW (See note.)	3 m	R88A-CAWF003S	R88A-CAWF003B
	5 m	R88A-CAWF005S	R88A-CAWF005B
	10 m	R88A-CAWF010S	R88A-CAWF010B
	15 m	R88A-CAWF015S	R88A-CAWF015B
	20 m	R88A-CAWF020S	R88A-CAWF020B
	30 m	R88A-CAWF030S	R88A-CAWF030B
	40 m	R88A-CAWF040S	R88A-CAWF040B
	50 m	R88A-CAWF050S	R88A-CAWF050B

Note For 4-kW and 5.5-kW Servomotors, there are separate connectors for power and brakes. For that reason, when a Servomotor with a brake is used, it will require both a Power Cable for a Servomotor without a brake (i.e., R88A-CAWE-□S or R88A-CAWF□S) and a Power Cable for a Servomotor with a brake (i.e., R88A-CAWE□B). The Power Cable for a Servomotor with a Brake is for brake line wiring only (2-core).

• Power Cable for 1,500-r/min Servomotors

Specifications		Model	
		Without brake	With brake
450 to 1.3 kW	3 m	R88A-CAWC003S	R88A-CAWC003B
	5 m	R88A-CAWC005S	R88A-CAWC005B
	10 m	R88A-CAWC010S	R88A-CAWC010B
	15 m	R88A-CAWC015S	R88A-CAWC015B
	20 m	R88A-CAWC020S	R88A-CAWC020B
	30 m	R88A-CAWC030S	R88A-CAWC030B
	40 m	R88A-CAWC040S	R88A-CAWC040B
	50 m	R88A-CAWC050S	R88A-CAWC050B
1.8 to 4.4 kW	3 m	R88A-CAWD003S	R88A-CAWD003B
	5 m	R88A-CAWD005S	R88A-CAWD005B
	10 m	R88A-CAWD010S	R88A-CAWD010B
	15 m	R88A-CAWD015S	R88A-CAWD015B
	20 m	R88A-CAWD020S	R88A-CAWD020B
	30 m	R88A-CAWD030S	R88A-CAWD030B
	40 m	R88A-CAWD040S	R88A-CAWD040B
	50 m	R88A-CAWD050S	R88A-CAWD050B
5.5 kW (See note 1.)	3 m	R88A-CAWE003S	R88A-CAWE003B
	5 m	R88A-CAWE005S	R88A-CAWE005B
	10 m	R88A-CAWE010S	R88A-CAWE010B
	15 m	R88A-CAWE015S	R88A-CAWE015B
	20 m	R88A-CAWE020S	R88A-CAWE020B
	30 m	R88A-CAWE030S	R88A-CAWE030B
	40 m	R88A-CAWE040S	R88A-CAWE040B
	50 m	R88A-CAWE050S	R88A-CAWE050B
7.5 to 11 kW (See note 1.)	3 m	R88A-CAWF003S	R88A-CAWE003B
	5 m	R88A-CAWF005S	R88A-CAWE005B
	10 m	R88A-CAWF010S	R88A-CAWE010B
	15 m	R88A-CAWF015S	R88A-CAWE015B
	20 m	R88A-CAWF020S	R88A-CAWE020B
	30 m	R88A-CAWF030S	R88A-CAWE030B
	40 m	R88A-CAWF040S	R88A-CAWE040B
	50 m	R88A-CAWF050S	R88A-CAWE050B

Note 1. For Servomotors of 5.5 kW and higher, there are separate connectors for power and brakes. Therefore, when a Servomotor with a brake is used, it will require both a Power Cable for a Servomotor without a brake (i.e., R88A-CAWE□S or R88A-CAWF□S) and a Power Cable for a Servomotor with a brake (i.e., R88A-CAWE-□B). The Power Cable for a Servomotor of 5.5 kW or higher with a Brake is for brake line wiring only (2-core).

Note 2. For details on preparing Power Cable for 15-kW Servomotors, refer to *Power Cable for 1,500-r/min Servomotors* under 3-2-3 Terminal Block Wiring.

■ Encoder Cables for Robot Cables (For Incremental or Absolute Encoders)

Specifications			Model		
For 3,000-r/min Servomotors	30 to 750 W	3 m	R88A-CRWA003CR		
		5 m	R88A-CRWA005CR		
		10 m	R88A-CRWA010CR		
		15 m	R88A-CRWA015CR		
		20 m	R88A-CRWA020CR		
		30 m	R88A-CRWA030CR		
		40 m	R88A-CRWA040CR		
		50 m	R88A-CRWA050CR		
	1 to 5 kW	3 m	R88A-CRWB003NR		
		5 m	R88A-CRWB005NR		
		10 m	R88A-CRWB010NR		
		15 m	R88A-CRWB015NR		
		20 m	R88A-CRWB020NR		
		30 m	R88A-CRWB030NR		
For 3,000-r/min Flat-style Servomotors	100 W to 1.5 kW	3 m	R88A-CRWA003CR		
		5 m	R88A-CRWA005CR		
		10 m	R88A-CRWA010CR		
		15 m	R88A-CRWA015CR		
		20 m	R88A-CRWA020CR		
		30 m	R88A-CRWA030CR		
		40 m	R88A-CRWA040CR		
		50 m	R88A-CRWA050CR		
		For 1,000-r/min Servomotors For 1,500-r/min Servomotors	300 W to 5.5 kW	3 m	R88A-CRWB003NR
				5 m	R88A-CRWB005NR
10 m	R88A-CRWB010NR				
15 m	R88A-CRWB015NR				
20 m	R88A-CRWB020NR				
450 W to 15 kW	30 m		R88A-CRWB030NR		
	40 m		R88A-CRWB040NR		
	50 m		R88A-CRWB050NR		

■ Power Cables for Robot Cables

• Power Cable for 3,000-r/min Servomotors

Specifications		Model	
		Without brake	With brake
30 to 750 W	3 m	R88A-CAWA003SR	R88A-CAWA003BR
	5 m	R88A-CAWA005SR	R88A-CAWA005BR
	10 m	R88A-CAWA010SR	R88A-CAWA010BR
	15 m	R88A-CAWA015SR	R88A-CAWA015BR
	20 m	R88A-CAWA020SR	R88A-CAWA020BR
	30 m	R88A-CAWA030SR	R88A-CAWA030BR
	40 m	R88A-CAWA040SR	R88A-CAWA040BR
	50 m	R88A-CAWA050SR	R88A-CAWA050BR
	1 to 2 kW	3 m	R88A-CAWC003SR
5 m		R88A-CAWC005SR	R88A-CAWC005BR
10 m		R88A-CAWC010SR	R88A-CAWC010BR
15 m		R88A-CAWC015SR	R88A-CAWC015BR
20 m		R88A-CAWC020SR	R88A-CAWC020BR
30 m		R88A-CAWC030SR	R88A-CAWC030BR
40 m		R88A-CAWC040SR	R88A-CAWC040BR
50 m		R88A-CAWC050SR	R88A-CAWC050BR
3 to 5 kW		3 m	R88A-CAWD003SR
	5 m	R88A-CAWD005SR	R88A-CAWD005BR
	10 m	R88A-CAWD010SR	R88A-CAWD010BR
	15 m	R88A-CAWD015SR	R88A-CAWD015BR
	20 m	R88A-CAWD020SR	R88A-CAWD020BR
	30 m	R88A-CAWD030SR	R88A-CAWD030BR
	50 m	R88A-CAWD050SR	R88A-CAWD050BR

• Power Cable for 3,000-r/min Flat-style Servomotors

Specifications		Model	
		Without brake	With brake
100 to 750 W	3 m	R88A-CAWA003SR	R88A-CAWA003BR
	5 m	R88A-CAWA005SR	R88A-CAWA005BR
	10 m	R88A-CAWA010SR	R88A-CAWA010BR
	15 m	R88A-CAWA015SR	R88A-CAWA015BR
	20 m	R88A-CAWA020SR	R88A-CAWA020BR
	30 m	R88A-CAWA030SR	R88A-CAWA030BR
	40 m	R88A-CAWA040SR	R88A-CAWA040BR
	50 m	R88A-CAWA050SR	R88A-CAWA050BR
1.5 kW	3 m	R88A-CAWB003SR	R88A-CAWB003BR
	5 m	R88A-CAWB005SR	R88A-CAWB005BR
	10 m	R88A-CAWB010SR	R88A-CAWB010BR
	15 m	R88A-CAWB015SR	R88A-CAWB015BR
	20 m	R88A-CAWB020SR	R88A-CAWB020BR
	30 m	R88A-CAWB030SR	R88A-CAWB030BR
	40 m	R88A-CAWB040SR	R88A-CAWB040BR
	50 m	R88A-CAWB050SR	R88A-CAWB050BR

• Power Cable for 1,000-r/min Servomotors

Specifications		Model	
		Without brake	With brake
300 to 900 W	3 m	R88A-CAWC003SR	R88A-CAWC003BR
	5 m	R88A-CAWC005SR	R88A-CAWC005BR
	10 m	R88A-CAWC010SR	R88A-CAWC010BR
	15 m	R88A-CAWC015SR	R88A-CAWC015BR
	20 m	R88A-CAWC020SR	R88A-CAWC020BR
	30 m	R88A-CAWC030SR	R88A-CAWC030BR
	40 m	R88A-CAWC040SR	R88A-CAWC040BR
	50 m	R88A-CAWC050SR	R88A-CAWC050BR
	1.2 to 3 kW	3 m	R88A-CAWD003SR
5 m		R88A-CAWD005SR	R88A-CAWD005BR
10 m		R88A-CAWD010SR	R88A-CAWD010BR
15 m		R88A-CAWD015SR	R88A-CAWD015BR
20 m		R88A-CAWD020SR	R88A-CAWD020BR
30 m		R88A-CAWD030SR	R88A-CAWD030BR
40 m		R88A-CAWD040SR	R88A-CAWD040BR
50 m		R88A-CAWD050SR	R88A-CAWD050BR

• Power Cable for 1,500-r/min Servomotors

Specifications		Model	
		Without brake	With brake
450 to 1.3 kW	3 m	R88A-CAWC003SR	R88A-CAWC003BR
	5 m	R88A-CAWC005SR	R88A-CAWC005BR
	10 m	R88A-CAWC010SR	R88A-CAWC010BR
	15 m	R88A-CAWC015SR	R88A-CAWC015BR
	20 m	R88A-CAWC020SR	R88A-CAWC020BR
	30 m	R88A-CAWC030SR	R88A-CAWC030BR
	40 m	R88A-CAWC040SR	R88A-CAWC040BR
	50 m	R88A-CAWC050SR	R88A-CAWC050BR
	1.8 to 4.4 kW	3 m	R88A-CAWD003SR
5 m		R88A-CAWD005SR	R88A-CAWD005BR
10 m		R88A-CAWD010SR	R88A-CAWD010BR
15 m		R88A-CAWD015SR	R88A-CAWD015BR
20 m		R88A-CAWD020SR	R88A-CAWD020BR
30 m		R88A-CAWD030SR	R88A-CAWD030BR
40 m		R88A-CAWD040SR	R88A-CAWD040BR
50 m		R88A-CAWD050SR	R88A-CAWD050BR

■ Servomotors

• 3,000-r/min Servomotors

Specifications			Model					
			With incremental encoder		With absolute encoder			
			Straight shaft without key	Straight shaft with key	Straight shaft without key	Straight shaft with key		
Without brake	100 V	30 W	R88M-W03030L	R88M-W03030L-S1	R88M-W03030S	R88M-W03030S-S1		
		50 W	R88M-W05030L	R88M-W05030L-S1	R88M-W05030S	R88M-W05030S-S1		
		100 W	R88M-W10030L	R88M-W10030L-S1	R88M-W10030S	R88M-W10030S-S1		
		200 W	R88M-W20030L	R88M-W20030L-S1	R88M-W20030S	R88M-W20030S-S1		
	200 V	30 W	R88M-W03030H	R88M-W03030H-S1	R88M-W03030T	R88M-W03030T-S1		
		50 W	R88M-W05030H	R88M-W05030H-S1	R88M-W05030T	R88M-W05030T-S1		
		100 W	R88M-W10030H	R88M-W10030H-S1	R88M-W10030T	R88M-W10030T-S1		
		200 W	R88M-W20030H	R88M-W20030H-S1	R88M-W20030T	R88M-W20030T-S1		
		400 W	R88M-W40030H	R88M-W40030H-S1	R88M-W40030T	R88M-W40030T-S1		
		750 W	R88M-W75030H	R88M-W75030H-S1	R88M-W75030T	R88M-W75030T-S1		
		1 kW	R88M-W1K030H	R88M-W1K030H-S2	R88M-W1K030T	R88M-W1K030T-S2		
		1.5 kW	R88M-W1K530H	R88M-W1K530H-S2	R88M-W1K530T	R88M-W1K530T-S2		
		2 kW	R88M-W2K030H	R88M-W2K030H-S2	R88M-W2K030T	R88M-W2K030T-S2		
		3 kW	R88M-W3K030H	R88M-W3K030H-S2	R88M-W3K030T	R88M-W3K030T-S2		
		4 kW	R88M-W4K030H	R88M-W4K030H-S2	R88M-W4K030T	R88M-W4K030T-S2		
		5 kW	R88M-W5K030H	R88M-W5K030H-S2	R88M-W5K030T	R88M-W5K030T-S2		
		With brake	100 V	30 W	R88M-W03030L-B	R88M-W03030L-BS1	R88M-W03030S-B	R88M-W03030S-BS1
				50 W	R88M-W05030L-B	R88M-W05030L-BS1	R88M-W05030S-B	R88M-W05030S-BS1
				100 W	R88M-W10030L-B	R88M-W10030L-BS1	R88M-W10030S-B	R88M-W10030S-BS1
				200 W	R88M-W20030L-B	R88M-W20030L-BS1	R88M-W20030S-B	R88M-W20030S-BS1
200 V	30 W		R88M-W03030H-B	R88M-W03030H-BS1	R88M-W03030T-B	R88M-W03030T-BS1		
	50 W		R88M-W05030H-B	R88M-W05030H-BS1	R88M-W05030T-B	R88M-W05030T-BS1		
	100 W		R88M-W10030H-B	R88M-W10030H-BS1	R88M-W10030T-B	R88M-W10030T-BS1		
	200 W		R88M-W20030H-B	R88M-W20030H-BS1	R88M-W20030T-B	R88M-W20030T-BS1		
	400 W		R88M-W40030H-B	R88M-W40030H-BS1	R88M-W40030T-B	R88M-W40030T-BS1		
	750 W		R88M-W75030H-B	R88M-W75030H-BS1	R88M-W75030T-B	R88M-W75030T-BS1		
	1 kW		R88M-W1K030H-B	R88M-W1K030H-BS2	R88M-W1K030T-B	R88M-W1K030T-BS2		
	1.5 kW		R88M-W1K530H-B	R88M-W1K530H-BS2	R88M-W1K530T-B	R88M-W1K530T-BS2		
	2 kW		R88M-W2K030H-B	R88M-W2K030H-BS2	R88M-W2K030T-B	R88M-W2K030T-BS2		
	3 kW		R88M-W3K030H-B	R88M-W3K030H-BS2	R88M-W3K030T-B	R88M-W3K030T-BS2		
	4 kW		R88M-W4K030H-B	R88M-W4K030H-BS2	R88M-W4K030T-B	R88M-W4K030T-BS2		
	5 kW		R88M-W5K030H-B	R88M-W5K030H-BS2	R88M-W5K030T-B	R88M-W5K030T-BS2		

• 3,000-r/min Flat-style Servomotors

Specifications			Model			
			With incremental encoder		With absolute encoder	
			Straight shaft without key	Straight shaft with key	Straight shaft without key	Straight shaft with key
Without brake	100 V	100 W	R88M-WP10030L	R88M-WP10030L-S1	R88M-WP10030S	R88M-WP10030S-S1
		200 W	R88M-WP20030L	R88M-WP20030L-S1	R88M-WP20030S	R88M-WP20030S-S1
	200 V	100 W	R88M-WP10030H	R88M-WP10030H-S1	R88M-WP10030T	R88M-WP10030T-S1
		200 W	R88M-WP20030H	R88M-WP20030H-S1	R88M-WP20030T	R88M-WP20030T-S1
		400 W	R88M-WP40030H	R88M-WP40030H-S1	R88M-WP40030T	R88M-WP40030T-S1
		750 W	R88M-WP75030H	R88M-WP75030H-S1	R88M-WP75030T	R88M-WP75030T-S1
1.5 kW	R88M-WP1K530H	R88M-WP1K530H-S1	R88M-WP1K530T	R88M-WP1K530T-S1		
With brake	100 V	100 W	R88M-WP10030L-B	R88M-WP10030L-BS1	R88M-WP10030S-B	R88M-WP10030S-BS1
		200 W	R88M-WP20030L-B	R88M-WP20030L-BS1	R88M-WP20030S-B	R88M-WP20030S-BS1
	200 V	100 W	R88M-WP10030H-B	R88M-WP10030H-BS1	R88M-WP10030T-B	R88M-WP10030T-BS1
		200 W	R88M-WP20030H-B	R88M-WP20030H-BS1	R88M-WP20030T-B	R88M-WP20030T-BS1
		400 W	R88M-WP40030H-B	R88M-WP40030H-BS1	R88M-WP40030T-B	R88M-WP40030T-BS1
		750 W	R88M-WP75030H-B	R88M-WP75030H-BS1	R88M-WP75030T-B	R88M-WP75030T-BS1
1.5 kW	R88M-WP1K530H-B	R88M-WP1K530H-BS1	R88M-WP1K530T-B	R88M-WP1K530T-BS1		

• 1,000-r/min Servomotors

Specifications			Model			
			With incremental encoder		With absolute encoder	
			Straight shaft without key	Straight shaft with key	Straight shaft without key	Straight shaft with key
Without brake	200 V	300 W	R88M-W30010H	R88M-W30010H-S2	R88M-W30010T	R88M-W30010T-S2
		600 W	R88M-W60010H	R88M-W60010H-S2	R88M-W60010T	R88M-W60010T-S2
		900 W	R88M-W90010H	R88M-W90010H-S2	R88M-W90010T	R88M-W90010T-S2
		1.2 kW	R88M-W1K210H	R88M-W1K210H-S2	R88M-W1K210T	R88M-W1K210T-S2
		2 kW	R88M-W2K010H	R88M-W2K010H-S2	R88M-W2K010T	R88M-W2K010T-S2
		3 kW	R88M-W3K010H	R88M-W3K010H-S2	R88M-W3K010T	R88M-W3K010T-S2
		4 kW	R88M-W4K010H	R88M-W4K010H-S2	R88M-W4K010T	R88M-W4K010T-S2
		5.5 kW	R88M-W5K510H	R88M-W5K510H-S2	R88M-W5K510T	R88M-W5K510T-S2
With brake	200 V	300 W	R88M-W30010H-B	R88M-W30010H-BS2	R88M-W30010T-B	R88M-W30010T-BS2
		600 W	R88M-W60010H-B	R88M-W60010H-BS2	R88M-W60010T-B	R88M-W60010T-BS2
		900 W	R88M-W90010H-B	R88M-W90010H-BS2	R88M-W90010T-B	R88M-W90010T-BS2
		1.2 kW	R88M-W1K210H-B	R88M-W1K210H-BS2	R88M-W1K210T-B	R88M-W1K210T-BS2
		2 kW	R88M-W2K010H-B	R88M-W2K010H-BS2	R88M-W2K010T-B	R88M-W2K010T-BS2
		3 kW	R88M-W3K010H-B	R88M-W3K010H-BS2	R88M-W3K010T-B	R88M-W3K010T-BS2
		4 kW	R88M-W4K010H-B	R88M-W4K010H-BS2	R88M-W4K010T-B	R88M-W4K010T-BS2
		5.5 kW	R88M-W5K510H-B	R88M-W5K510H-BS2	R88M-W5K510T-B	R88M-W5K510T-BS2

• 1,500-r/min Servomotors

Specifications			Model			
			With incremental encoder		With absolute encoder	
			Straight shaft without key	Straight shaft with key	Straight shaft without key	Straight shaft with key
Without brake	200 V	450 W	---	---	R88M-W45015T	R88M-W45015T-S2
		850 W	---	---	R88M-W85015T	R88M-W85015T-S2
		1.3 kW	---	---	R88M-W1K315T	R88M-W1K315T-S2
		1.8 kW	---	---	R88M-W1K815T	R88M-W1K815T-S2
		2.9 kW	---	---	R88M-W2K915T	R88M-W2K915T-S2
		4.4 kW	---	---	R88M-W4K415T	R88M-W4K415T-S2
		5.5 kW	---	---	R88M-W5K515T	R88M-W5K515T-S2
		7.5 kW	---	---	R88M-W7K515T	R88M-W7K515T-S2
		11 kW	---	---	R88M-W11K015T	R88M-W11K015T-S2
		15 kW	---	---	R88M-W15K015T	R88M-W15K015T-S2
With brake	200 V	450 W	---	---	R88M-W45015T-B	R88M-W45015T-BS2
		850 W	---	---	R88M-W85015T-B	R88M-W85015T-BS2
		1.3 kW	---	---	R88M-W1K315T-B	R88M-W1K315T-BS2
		1.8 kW	---	---	R88M-W1K815T-B	R88M-W1K815T-BS2
		2.9 kW	---	---	R88M-W2K915T-B	R88M-W2K915T-BS2
		4.4 kW	---	---	R88M-W4K415T-B	R88M-W4K415T-BS2
		5.5 kW	---	---	R88M-W5K515T-B	R88M-W5K515T-BS2
		7.5 kW	---	---	R88M-W7K515T-B	R88M-W7K515T-BS2
		11 kW	---	---	R88M-W11K015T-B	R88M-W11K015T-BS2
		15 kW	---	---	R88M-W15K015T-B	R88M-W15K015T-BS2

■ IP67 (Waterproof) Servomotors

• 3,000-r/min Servomotors

Specifications			Model			
			With incremental encoder		With absolute encoder	
			Straight shaft without key	Straight shaft with key	Straight shaft without key	Straight shaft with key
Without brake	200 V	1 kW	R88M-W1K030H-O	R88M-W1K030H-OS2	R88M-W1K030T-O	R88M-W1K030T-OS2
		1.5 kW	R88M-W1K530H-O	R88M-W1K530H-OS2	R88M-W1K530T-O	R88M-W1K530T-OS2
		2 kW	R88M-W2K030H-O	R88M-W2K030H-OS2	R88M-W2K030T-O	R88M-W2K030T-OS2
		3 kW	R88M-W3K030H-O	R88M-W3K030H-OS2	R88M-W3K030T-O	R88M-W3K030T-OS2
		4 kW	R88M-W4K030H-O	R88M-W4K030H-OS2	R88M-W4K030T-O	R88M-W4K030T-OS2
		5 kW	R88M-W5K030H-O	R88M-W5K030H-OS2	R88M-W5K030T-O	R88M-W5K030T-OS2
With brake	200 V	1 kW	R88M-W1K030H-BO	R88M-W1K030H-BOS2	R88M-W1K030T-BO	R88M-W1K030T-BOS2
		1.5 kW	R88M-W1K530H-BO	R88M-W1K530H-BOS2	R88M-W1K530T-BO	R88M-W1K530T-BOS2
		2 kW	R88M-W2K030H-BO	R88M-W2K030H-BOS2	R88M-W2K030T-BO	R88M-W2K030T-BOS2
		3 kW	R88M-W3K030H-BO	R88M-W3K030H-BOS2	R88M-W3K030T-BO	R88M-W3K030T-BOS2
		4 kW	R88M-W4K030H-BO	R88M-W4K030H-BOS2	R88M-W4K030T-BO	R88M-W4K030T-BOS2
		5 kW	R88M-W5K030H-BO	R88M-W5K030H-BOS2	R88M-W5K030T-BO	R88M-W5K030T-BOS2

• 3,000-r/min Flat-style Servomotors

Specifications			Model			
			With incremental encoder		With absolute encoder	
			Straight shaft without key	Straight shaft with key	Straight shaft without key	Straight shaft with key
Without brake	100 V	100 W	R88M-WP10030L-W	R88M-WP10030L-WS1	R88M-WP10030S-W	R88M-WP10030S-WS1
		200 W	R88M-WP20030L-W	R88M-WP20030L-WS1	R88M-WP20030S-W	R88M-WP20030S-WS1
	200 V	100 W	R88M-WP10030H-W	R88M-WP10030H-WS1	R88M-WP10030T-W	R88M-WP10030T-WS1
		200 W	R88M-WP20030H-W	R88M-WP20030H-WS1	R88M-WP20030T-W	R88M-WP20030T-WS1
		400 W	R88M-WP40030H-W	R88M-WP40030H-WS1	R88M-WP40030T-W	R88M-WP40030T-WS1
		750 W	R88M-WP75030H-W	R88M-WP75030H-WS1	R88M-WP75030T-W	R88M-WP75030T-WS1
		1.5 kW	R88M-WP1K530H-W	R88M-WP1K530H-WS1	R88M-WP1K530T-W	R88M-WP1K530T-WS1
With brake	100 V	100 W	R88M-WP10030L-BW	R88M-WP10030L-BWS1	R88M-WP10030S-BW	R88M-WP10030S-BWS1
		200 W	R88M-WP20030L-BW	R88M-WP20030L-BWS1	R88M-WP20030S-BW	R88M-WP20030S-BWS1
	200 V	100 W	R88M-WP10030H-BW	R88M-WP10030H-BWS1	R88M-WP10030T-BW	R88M-WP10030T-BWS1
		200 W	R88M-WP20030H-BW	R88M-WP20030H-BWS1	R88M-WP20030T-BW	R88M-WP20030T-BWS1
		400 W	R88M-WP40030H-BW	R88M-WP40030H-BWS1	R88M-WP40030T-BW	R88M-WP40030T-BWS1
		750 W	R88M-WP75030H-BW	R88M-WP75030H-BWS1	R88M-WP75030T-BW	R88M-WP75030T-BWS1
		1.5 kW	R88M-WP1K530H-BW	R88M-WP1K530H-BWS1	R88M-WP1K530T-BW	R88M-WP1K530T-BWS1

• 1,000-r/min Servomotors

Specifications			Model			
			With incremental encoder		With absolute encoder	
			Straight shaft without key	Straight shaft with key	Straight shaft without key	Straight shaft with key
Without brake	200 V	300 W	R88M-W30010H-O	R88M-W30010H-OS2	R88M-W30010T-O	R88M-W30010T-OS2
		600 W	R88M-W60010H-O	R88M-W60010H-OS2	R88M-W60010T-O	R88M-W60010T-OS2
		900 W	R88M-W90010H-O	R88M-W90010H-OS2	R88M-W90010T-O	R88M-W90010T-OS2
		1.2 kW	R88M-W1K210H-O	R88M-W1K210H-OS2	R88M-W1K210T-O	R88M-W1K210T-OS2
		2 kW	R88M-W2K010H-O	R88M-W2K010H-OS2	R88M-W2K010T-O	R88M-W2K010T-OS2
		3 kW	R88M-W3K010H-O	R88M-W3K010H-OS2	R88M-W3K010T-O	R88M-W3K010T-OS2
		4 kW	R88M-W4K010H-O	R88M-W4K010H-OS2	R88M-W4K010T-O	R88M-W4K010T-OS2
		5.5 kW	R88M-W5K510H-O	R88M-W5K510H-OS2	R88M-W5K510T-O	R88M-W5K510T-OS2
With brake	200 V	300 W	R88M-W30010H-BO	R88M-W30010H-BOS2	R88M-W30010T-BO	R88M-W30010T-BOS2
		600 W	R88M-W60010H-BO	R88M-W60010H-BOS2	R88M-W60010T-BO	R88M-W60010T-BOS2
		900 W	R88M-W90010H-BO	R88M-W90010H-BOS2	R88M-W90010T-BO	R88M-W90010T-BOS2
		1.2 kW	R88M-W1K210H-BO	R88M-W1K210H-BOS2	R88M-W1K210T-BO	R88M-W1K210T-BOS2
		2 kW	R88M-W2K010H-BO	R88M-W2K010H-BOS2	R88M-W2K010T-BO	R88M-W2K010T-BOS2
		3 kW	R88M-W3K010H-BO	R88M-W3K010H-BOS2	R88M-W3K010T-BO	R88M-W3K010T-BOS2
		4 kW	R88M-W4K010H-BO	R88M-W4K010H-BOS2	R88M-W4K010T-BO	R88M-W4K010T-BOS2
		5.5 kW	R88M-W5K510H-BO	R88M-W5K510H-BOS2	R88M-W5K510T-BO	R88M-W5K510T-BOS2

• 1,500-r/min Servomotors

Specifications			Model			
			With incremental encoder		With absolute encoder	
			Straight shaft without key	Straight shaft with key	Straight shaft without key	Straight shaft with key
Without brake	200 V	450 W	---	---	R88M-W45015T-O	R88M-W45015T-OS2
		850 W	---	---	R88M-W85015T-O	R88M-W85015T-OS2
		1.3 kW	---	---	R88M-W1K315T-O	R88M-W1K315T-OS2
		1.8 kW	---	---	R88M-W1K815T-O	R88M-W1K815T-OS2
		2.9 kW	---	---	R88M-W2K915T-O	R88M-W2K915T-OS2
		4.4 kW	---	---	R88M-W4K415T-O	R88M-W4K415T-OS2
		5.5 kW	---	---	R88M-W5K515T-O	R88M-W5K515T-OS2
		7.5 kW	---	---	R88M-W7K515T-O	R88M-W7K515T-OS2
		11 kW	---	---	R88M-W11K015T-O	R88M-W11K015T-OS2
		15 kW	---	---	R88M-W15K015T-O	R88M-W15K015T-OS2
With brake	200 V	450 W	---	---	R88M-W45015T-BO	R88M-W45015T-BOS2
		850 W	---	---	R88M-W85015T-BO	R88M-W85015T-BOS2
		1.3 kW	---	---	R88M-W1K315T-BO	R88M-W1K315T-BOS2
		1.8 kW	---	---	R88M-W1K815T-BO	R88M-W1K815T-BOS2
		2.9 kW	---	---	R88M-W2K915T-BO	R88M-W2K915T-BOS2
		4.4 kW	---	---	R88M-W4K415T-BO	R88M-W4K415T-BOS2
		5.5 kW	---	---	R88M-W5K515T-BO	R88M-W5K515T-BOS2
		7.5 kW	---	---	R88M-W7K515T-BO	R88M-W7K515T-BOS2
		11 kW	---	---	R88M-W11K015T-BO	R88M-W11K015T-BOS2
		15 kW	---	---	R88M-W15K015T-BO	R88M-W15K015T-BOS2

■ Servomotors with Gears

● Combination Table for Servomotors with Standard Gears

Standard Gears are highly accurate gears, with a maximum backlash of 3 degrees. The standard shaft is a straight shaft with a key. (Models without keys can also be manufactured for 3,000-r/min motors from 30 to 750 W and for 3,000-r/min flat-style motors. Models without keys have a suffix of -G□□B.)

Note A check mark in a box indicates that the two models can be combined. If the box is unchecked, then the models cannot be combined.

● 3,000-r/min Servomotors

Specifications		Basic model	Gear (deceleration rate)							
			1/5	1/9	1/11	1/20	1/21	1/29	1/33	1/45
			-G05BJ	-G09BJ	-G11BJ	-G20BJ	-G21BJ	-G29BJ	-G33BJ	-G45BJ
100 V	30 W	R88M-W03030L/S	✓	✓			✓		✓	
	50 W	R88M-W05030L/S	✓	✓			✓		✓	
	100 W	R88M-W10030L/S	✓		✓		✓		✓	
	200 W	R88M-W20030L/S	✓		✓		✓		✓	
200 V	30 W	R88M-W03030H/T	✓	✓			✓		✓	
	50 W	R88M-W05030H/T	✓	✓			✓		✓	
	100 W	R88M-W10030H/T	✓		✓		✓		✓	
	200 W	R88M-W20030H/T	✓		✓		✓		✓	
	400 W	R88M-W40030H/T	✓		✓		✓		✓	
	750 W	R88M-W75030H/T	✓		✓		✓		✓	
	1 kW	R88M-W1K030H/T	✓	✓		✓		✓		✓
	1.5 kW	R88M-W1K530H/T	✓	✓		✓		✓		✓
	2 kW	R88M-W2K030H/T	✓	✓		✓		✓		✓
	3 kW	R88M-W3K030H/T	✓	✓		✓		✓		✓
	4 kW	R88M-W4K030H/T	✓	✓		✓		✓		
5 kW	R88M-W5K030H/T	✓	✓		✓					

● 3,000-r/min Flat-style Servomotors

Specifications		Basic model	Gear (deceleration rate)							
			1/5	1/9	1/11	1/20	1/21	1/29	1/33	1/45
			-G05BJ	-G09BJ	-G11BJ	-G20BJ	-G21BJ	-G29BJ	-G33BJ	-G45BJ
100 V	100 W	R88M-WP10030L/S	✓		✓		✓		✓	
	200 W	R88M-WP20030L/S	✓		✓		✓		✓	
200 V	100 W	R88M-WP10030H/T	✓		✓		✓		✓	
	200 W	R88M-WP20030H/T	✓		✓		✓		✓	
	400 W	R88M-WP40030H/T	✓		✓		✓		✓	
	750 W	R88M-WP75030H/T	✓		✓		✓		✓	
	1.5 kW	R88M-WP1K530H/T	✓		✓		✓		✓	

• 1,000-r/min Servomotors

Specifications		Basic model	Gear (deceleration rate)							
			1/5	1/9	1/11	1/20	1/21	1/29	1/33	1/45
			-G05BJ	-G09BJ	-G11BJ	-G20BJ	-G21BJ	-G29BJ	-G33BJ	-G45BJ
200 V	300 W	R88M-W30010H/T	✓	✓		✓		✓		✓
	600 W	R88M-W60010H/T	✓	✓		✓		✓		✓
	900 W	R88M-W90010H/T	✓	✓		✓		✓		✓
	1.2 kW	R88M-W1K210H/T	✓	✓		✓		✓		✓
	2 kW	R88M-W2K010H/T	✓	✓		✓				
	3 kW	R88M-W3K010H/T	✓	✓						
	4 kW	R88M-W4K010H/T								
	5.5 kW	R88M-W5K510H/T								

• 1,500-r/min Servomotors

Specifications		Basic model	Gear (deceleration rate)							
			1/5	1/9	1/11	1/20	1/21	1/29	1/33	1/45
			-G05BJ	-G09BJ	-G11BJ	-G20BJ	-G21BJ	-G29BJ	-G33BJ	-G45BJ
200 V	450 W	R88M-W45015T	✓	✓		✓		✓		✓
	850 W	R88M-W85015T	✓	✓		✓		✓		✓
	1.3 kW	R88M-W1K315T	✓	✓		✓		✓		✓
	1.8 kW	R88M-W1K815T	✓	✓		✓		✓		
	2.9 kW	R88M-W2K915T	✓	✓		✓				
	4.4 kW	R88M-W4K415T	✓	✓						
	5.5 kW	R88M-W5K515T								
	7.5 kW	R88M-W7K515T								
	11 kW	R88M-W11K015T								
	15 kW	R88M-W15K015T								

• **Combination Table for Servomotors with Economy Gears**

Economy Gears are low-cost gears, with a maximum backlash of 45 degrees. The shaft is a straight shaft with key. Models without keys are not available.

Note 1. The 1,000-r/min and 1,500-r/min Servomotors cannot be combined with Economy Gears.

Note 2. A check mark in a box indicates that the two models can be combined. If the box is unchecked, then the models cannot be combined.

• 3,000-r/min Servomotors

Specifications		Basic model	Gear (deceleration rate)			
			1/5	1/9	1/15	1/25
			-G05CJ	-G09CJ	-G15CJ	-G25CJ
100 V	30 W	R88M-W03030L/S				
	50 W	R88M-W05030L/S				
	100 W	R88M-W10030L/S	✓	✓	✓	✓
	200 W	R88M-W20030L/S	✓	✓	✓	✓
200 V	30 W	R88M-W03030H/T				
	50 W	R88M-W05030H/T				
	100 W	R88M-W10030H/T	✓	✓	✓	✓
	200 W	R88M-W20030H/T	✓	✓	✓	✓
	400 W	R88M-W40030H/T	✓	✓	✓	✓
	750 W	R88M-W75030H/T	✓	✓	✓	✓
	1 kW	R88M-W1K030H/T				
	1.5 kW	R88M-W1K530H/T				
	2 kW	R88M-W2K030H/T				
	3 kW	R88M-W3K030H/T				
	4 kW	R88M-W4K030H/T				
	5 kW	R88M-W5K030H/T				

• 3,000-r/min Flat-style Servomotors

Specifications		Basic model	Gear (deceleration rate)			
			1/5	1/9	1/15	1/25
			-G05CJ	-G09CJ	-G15CJ	-G25CJ
100 V	100 W	R88M-WP10030L/S	✓	✓	✓	✓
	200 W	R88M-WP20030L/S	✓	✓	✓	✓
200 V	100 W	R88M-WP10030H/T	✓	✓	✓	✓
	200 W	R88M-WP20030H/T	✓	✓	✓	✓
	400 W	R88M-WP40030H/T	✓	✓	✓	✓
	750 W	R88M-WP75030H/T	✓	✓	✓	✓
	1.5 kW	R88M-WP1K530H/T				

- Servomotors with Standard Gears (Straight Shaft with Key)
- 3,000-r/min Servomotors

Specifications			Model				
			With incremental encoder		With absolute encoder		
			Without brake	With brake	Without brake	With brake	
100 V	30 W	1/5	R88M-W03030L-G05BJ	R88M-W03030L-BG05BJ	R88M-W03030S-G05BJ	R88M-W03030S-BG05BJ	
		1/9	R88M-W03030L-G09BJ	R88M-W03030L-BG09BJ	R88M-W03030S-G09BJ	R88M-W03030S-BG09BJ	
		1/21	R88M-W03030L-G21BJ	R88M-W03030L-BG21BJ	R88M-W03030S-G21BJ	R88M-W03030S-BG21BJ	
		1/33	R88M-W03030L-G33BJ	R88M-W03030L-BG33BJ	R88M-W03030S-G33BJ	R88M-W03030S-BG33BJ	
	50 W	1/5	R88M-W05030L-G05BJ	R88M-W05030L-BG05BJ	R88M-W05030S-G05BJ	R88M-W05030S-BG05BJ	
		1/9	R88M-W05030L-G09BJ	R88M-W05030L-BG09BJ	R88M-W05030S-G09BJ	R88M-W05030S-BG09BJ	
		1/21	R88M-W05030L-G21BJ	R88M-W05030L-BG21BJ	R88M-W05030S-G21BJ	R88M-W05030S-BG21BJ	
		1/33	R88M-W05030L-G33BJ	R88M-W05030L-BG33BJ	R88M-W05030S-G33BJ	R88M-W05030S-BG33BJ	
	100 W	1/5	R88M-W10030L-G05BJ	R88M-W10030L-BG05BJ	R88M-W10030S-G05BJ	R88M-W10030S-BG05BJ	
		1/11	R88M-W10030L-G11BJ	R88M-W10030L-BG11BJ	R88M-W10030S-G11BJ	R88M-W10030S-BG11BJ	
		1/21	R88M-W10030L-G21BJ	R88M-W10030L-BG21BJ	R88M-W10030S-G21BJ	R88M-W10030S-BG21BJ	
		1/33	R88M-W10030L-G33BJ	R88M-W10030L-BG33BJ	R88M-W10030S-G33BJ	R88M-W10030S-BG33BJ	
	200 W	1/5	R88M-W20030L-G05BJ	R88M-W20030L-BG05BJ	R88M-W20030S-G05BJ	R88M-W20030S-BG05BJ	
		1/11	R88M-W20030L-G11BJ	R88M-W20030L-BG11BJ	R88M-W20030S-G11BJ	R88M-W20030S-BG11BJ	
		1/21	R88M-W20030L-G21BJ	R88M-W20030L-BG21BJ	R88M-W20030S-G21BJ	R88M-W20030S-BG21BJ	
		1/33	R88M-W20030L-G33BJ	R88M-W20030L-BG33BJ	R88M-W20030S-G33BJ	R88M-W20030S-BG33BJ	
	200 V	30 W	1/5	R88M-W03030H-G05BJ	R88M-W03030H-BG05BJ	R88M-W03030T-G05BJ	R88M-W03030T-BG05BJ
			1/9	R88M-W03030H-G09BJ	R88M-W03030H-BG09BJ	R88M-W03030T-G09BJ	R88M-W03030T-BG09BJ
			1/21	R88M-W03030H-G21BJ	R88M-W03030H-BG21BJ	R88M-W03030T-G21BJ	R88M-W03030T-BG21BJ
			1/33	R88M-W03030H-G33BJ	R88M-W03030H-BG33BJ	R88M-W03030T-G33BJ	R88M-W03030T-BG33BJ
50 W		1/5	R88M-W05030H-G05BJ	R88M-W05030H-BG05BJ	R88M-W05030T-G05BJ	R88M-W05030T-BG05BJ	
		1/9	R88M-W05030H-G09BJ	R88M-W05030H-BG09BJ	R88M-W05030T-G09BJ	R88M-W05030T-BG09BJ	
		1/21	R88M-W05030H-G21BJ	R88M-W05030H-BG21BJ	R88M-W05030T-G21BJ	R88M-W05030T-BG21BJ	
		1/33	R88M-W05030H-G33BJ	R88M-W05030H-BG33BJ	R88M-W05030T-G33BJ	R88M-W05030T-BG33BJ	
100 W		1/5	R88M-W10030H-G05BJ	R88M-W10030H-BG05BJ	R88M-W10030T-G05BJ	R88M-W10030T-BG05BJ	
		1/11	R88M-W10030H-G11BJ	R88M-W10030H-BG11BJ	R88M-W10030T-G11BJ	R88M-W10030T-BG11BJ	
		1/21	R88M-W10030H-G21BJ	R88M-W10030H-BG21BJ	R88M-W10030T-G21BJ	R88M-W10030T-BG21BJ	
		1/33	R88M-W10030H-G33BJ	R88M-W10030H-BG33BJ	R88M-W10030T-G33BJ	R88M-W10030T-BG33BJ	
200 W		1/5	R88M-W20030H-G05BJ	R88M-W20030H-BG05BJ	R88M-W20030T-G05BJ	R88M-W20030T-BG05BJ	
		1/11	R88M-W20030H-G11BJ	R88M-W20030H-BG11BJ	R88M-W20030T-G11BJ	R88M-W20030T-BG11BJ	
		1/21	R88M-W20030H-G21BJ	R88M-W20030H-BG21BJ	R88M-W20030T-G21BJ	R88M-W20030T-BG21BJ	
		1/33	R88M-W20030H-G33BJ	R88M-W20030H-BG33BJ	R88M-W20030T-G33BJ	R88M-W20030T-BG33BJ	
400 W		1/5	R88M-W40030H-G05BJ	R88M-W40030H-BG05BJ	R88M-W40030T-G05BJ	R88M-W40030T-BG05BJ	
		1/11	R88M-W40030H-G11BJ	R88M-W40030H-BG11BJ	R88M-W40030T-G11BJ	R88M-W40030T-BG11BJ	
		1/21	R88M-W40030H-G21BJ	R88M-W40030H-BG21BJ	R88M-W40030T-G21BJ	R88M-W40030T-BG21BJ	
		1/33	R88M-W40030H-G33BJ	R88M-W40030H-BG33BJ	R88M-W40030T-G33BJ	R88M-W40030T-BG33BJ	
750 W		1/5	R88M-W75030H-G05BJ	R88M-W75030H-BG05BJ	R88M-W75030T-G05BJ	R88M-W75030T-BG05BJ	
		1/11	R88M-W75030H-G11BJ	R88M-W75030H-BG11BJ	R88M-W75030T-G11BJ	R88M-W75030T-BG11BJ	
		1/21	R88M-W75030H-G21BJ	R88M-W75030H-BG21BJ	R88M-W75030T-G21BJ	R88M-W75030T-BG21BJ	
		1/33	R88M-W75030H-G33BJ	R88M-W75030H-BG33BJ	R88M-W75030T-G33BJ	R88M-W75030T-BG33BJ	
1 kW		1/5	R88M-W1K030H-G05BJ	R88M-W1K030H-BG05BJ	R88M-W1K030T-G05BJ	R88M-W1K030T-BG05BJ	
		1/9	R88M-W1K030H-G09BJ	R88M-W1K030H-BG09BJ	R88M-W1K030T-G09BJ	R88M-W1K030T-BG09BJ	
		1/20	R88M-W1K030H-G20BJ	R88M-W1K030H-BG20BJ	R88M-W1K030T-G20BJ	R88M-W1K030T-BG20BJ	
		1/29	R88M-W1K030H-G29BJ	R88M-W1K030H-BG29BJ	R88M-W1K030T-G29BJ	R88M-W1K030T-BG29BJ	
		1/45	R88M-W1K030H-G45BJ	R88M-W1K030H-BG45BJ	R88M-W1K030T-G45BJ	R88M-W1K030T-BG45BJ	
1.5 kW		1/5	R88M-W1K530H-G05BJ	R88M-W1K530H-BG05BJ	R88M-W1K530T-G05BJ	R88M-W1K530T-BG05BJ	
		1/9	R88M-W1K530H-G09BJ	R88M-W1K530H-BG09BJ	R88M-W1K530T-G09BJ	R88M-W1K530T-BG09BJ	
		1/20	R88M-W1K530H-G20BJ	R88M-W1K530H-BG20BJ	R88M-W1K530T-G20BJ	R88M-W1K530T-BG20BJ	
		1/29	R88M-W1K530H-G29BJ	R88M-W1K530H-BG29BJ	R88M-W1K530T-G29BJ	R88M-W1K530T-BG29BJ	
		1/45	R88M-W1K530H-G45BJ	R88M-W1K530H-BG45BJ	R88M-W1K530T-G45BJ	R88M-W1K530T-BG45BJ	

Specifications			Model			
			With incremental encoder		With absolute encoder	
			Without brake	With brake	Without brake	With brake
200 V	2 kW	1/5	R88M-W2K030H-G05BJ	R88M-W2K030H-BG05BJ	R88M-W2K030T-G05BJ	R88M-W2K030T-BG05BJ
		1/9	R88M-W2K030H-G09BJ	R88M-W2K030H-BG09BJ	R88M-W2K030T-G09BJ	R88M-W2K030T-BG09BJ
		1/20	R88M-W2K030H-G20BJ	R88M-W2K030H-BG20BJ	R88M-W2K030T-G20BJ	R88M-W2K030T-BG20BJ
		1/29	R88M-W2K030H-G29BJ	R88M-W2K030H-BG29BJ	R88M-W2K030T-G29BJ	R88M-W2K030T-BG29BJ
		1/45	R88M-W2K030H-G45BJ	R88M-W2K030H-BG45BJ	R88M-W2K030T-G45BJ	R88M-W2K030T-BG45BJ
	3 kW	1/5	R88M-W3K030H-G05BJ	R88M-W3K030H-BG05BJ	R88M-W3K030T-G05BJ	R88M-W3K030T-BG05BJ
		1/9	R88M-W3K030H-G09BJ	R88M-W3K030H-BG09BJ	R88M-W3K030T-G09BJ	R88M-W3K030T-BG09BJ
		1/20	R88M-W3K030H-G20BJ	R88M-W3K030H-BG20BJ	R88M-W3K030T-G20BJ	R88M-W3K030T-BG20BJ
		1/29	R88M-W3K030H-G29BJ	R88M-W3K030H-BG29BJ	R88M-W3K030T-G29BJ	R88M-W3K030T-BG29BJ
		1/45	R88M-W3K030H-G45BJ	R88M-W3K030H-BG45BJ	R88M-W3K030T-G45BJ	R88M-W3K030T-BG45BJ
	4 kW	1/5	R88M-W4K030H-G05BJ	R88M-W4K030H-BG05BJ	R88M-W4K030T-G05BJ	R88M-W4K030T-BG05BJ
		1/9	R88M-W4K030H-G09BJ	R88M-W4K030H-BG09BJ	R88M-W4K030T-G09BJ	R88M-W4K030T-BG09BJ
		1/20	R88M-W4K030H-G20BJ	R88M-W4K030H-BG20BJ	R88M-W4K030T-G20BJ	R88M-W4K030T-BG20BJ
		1/29	R88M-W4K030H-G29BJ	R88M-W4K030H-BG29BJ	R88M-W4K030T-G29BJ	R88M-W4K030T-BG29BJ
	5 kW	1/5	R88M-W5K030H-G05BJ	R88M-W5K030H-BG05BJ	R88M-W5K030T-G05BJ	R88M-W5K030T-BG05BJ
		1/9	R88M-W5K030H-G09BJ	R88M-W5K030H-BG09BJ	R88M-W5K030T-G09BJ	R88M-W5K030T-BG09BJ
		1/20	R88M-W5K030H-G20BJ	R88M-W5K030H-BG20BJ	R88M-W5K030T-G20BJ	R88M-W5K030T-BG20BJ

• 3,000-r/min Flat-style Servomotors

Specifications			Model					
			With incremental encoder		With absolute encoder			
			Without brake	With brake	Without brake	With brake		
100 V	100 W	1/5	R88M-WP10030L-G05BJ	R88M-WP10030L-BG05BJ	R88M-WP10030S-G05BJ	R88M-WP10030S-BG05BJ		
		1/11	R88M-WP10030L-G11BJ	R88M-WP10030L-BG11BJ	R88M-WP10030S-G11BJ	R88M-WP10030S-BG11BJ		
		1/21	R88M-WP10030L-G21BJ	R88M-WP10030L-BG21BJ	R88M-WP10030S-G21BJ	R88M-WP10030S-BG21BJ		
		1/33	R88M-WP10030L-G33BJ	R88M-WP10030L-BG33BJ	R88M-WP10030S-G33BJ	R88M-WP10030S-BG33BJ		
	200 W	1/5	R88M-WP20030L-G05BJ	R88M-WP20030L-BG05BJ	R88M-WP20030S-G05BJ	R88M-WP20030S-BG05BJ		
		1/11	R88M-WP20030L-G11BJ	R88M-WP20030L-BG11BJ	R88M-WP20030S-G11BJ	R88M-WP20030S-BG11BJ		
		1/21	R88M-WP20030L-G21BJ	R88M-WP20030L-BG21BJ	R88M-WP20030S-G21BJ	R88M-WP20030S-BG21BJ		
		1/33	R88M-WP20030L-G33BJ	R88M-WP20030L-BG33BJ	R88M-WP20030S-G33BJ	R88M-WP20030S-BG33BJ		
		200 V	100 W	1/5	R88M-WP10030H-G05BJ	R88M-WP10030H-BG05BJ	R88M-WP10030T-G05BJ	R88M-WP10030T-BG05BJ
				1/11	R88M-WP10030H-G11BJ	R88M-WP10030H-BG11BJ	R88M-WP10030T-G11BJ	R88M-WP10030T-BG11BJ
1/21	R88M-WP10030H-G21BJ			R88M-WP10030H-BG21BJ	R88M-WP10030T-G21BJ	R88M-WP10030T-BG21BJ		
1/33	R88M-WP10030H-G33BJ			R88M-WP10030H-BG33BJ	R88M-WP10030T-G33BJ	R88M-WP10030T-BG33BJ		
200 W	1/5		R88M-WP20030H-G05BJ	R88M-WP20030H-BG05BJ	R88M-WP20030T-G05BJ	R88M-WP20030T-BG05BJ		
	1/11		R88M-WP20030H-G11BJ	R88M-WP20030H-BG11BJ	R88M-WP20030T-G11BJ	R88M-WP20030T-BG11BJ		
	1/21		R88M-WP20030H-G21BJ	R88M-WP20030H-BG21BJ	R88M-WP20030T-G21BJ	R88M-WP20030T-BG21BJ		
	1/33		R88M-WP20030H-G33BJ	R88M-WP20030H-BG33BJ	R88M-WP20030T-G33BJ	R88M-WP20030T-BG33BJ		
400 W	1/5		R88M-WP40030H-G05BJ	R88M-WP40030H-BG05BJ	R88M-WP40030T-G05BJ	R88M-WP40030T-BG05BJ		
	1/11		R88M-WP40030H-G11BJ	R88M-WP40030H-BG11BJ	R88M-WP40030T-G11BJ	R88M-WP40030T-BG11BJ		
	1/21		R88M-WP40030H-G21BJ	R88M-WP40030H-BG21BJ	R88M-WP40030T-G21BJ	R88M-WP40030T-BG21BJ		
	1/33		R88M-WP40030H-G33BJ	R88M-WP40030H-BG33BJ	R88M-WP40030T-G33BJ	R88M-WP40030T-BG33BJ		
750 W	1/5	R88M-WP75030H-G05BJ	R88M-WP75030H-BG05BJ	R88M-WP75030T-G05BJ	R88M-WP75030T-BG05BJ			
	1/11	R88M-WP75030H-G11BJ	R88M-WP75030H-BG11BJ	R88M-WP75030T-G11BJ	R88M-WP75030T-BG11BJ			
	1/21	R88M-WP75030H-G21BJ	R88M-WP75030H-BG21BJ	R88M-WP75030T-G21BJ	R88M-WP75030T-BG21BJ			
	1/33	R88M-WP75030H-G33BJ	R88M-WP75030H-BG33BJ	R88M-WP75030T-G33BJ	R88M-WP75030T-BG33BJ			
1.5 kW	1/5	R88M-WP1K530H-G05BJ	R88M-WP1K530H-BG05BJ	R88M-WP1K530T-G05BJ	R88M-WP1K530T-BG05BJ			
	1/11	R88M-WP1K530H-G11BJ	R88M-WP1K530H-BG11BJ	R88M-WP1K530T-G11BJ	R88M-WP1K530T-BG11BJ			
	1/21	R88M-WP1K530H-G21BJ	R88M-WP1K530H-BG21BJ	R88M-WP1K530T-G21BJ	R88M-WP1K530T-BG21BJ			
	1/33	R88M-WP1K530H-G33BJ	R88M-WP1K530H-BG33BJ	R88M-WP1K530T-G33BJ	R88M-WP1K530T-BG33BJ			

• 1,000-r/min Servomotors

Specifications			Model			
			With incremental encoder		With absolute encoder	
			Without brake	With brake	Without brake	With brake
200 V	300 W	1/5	R88M-W30010H-G05BJ	R88M-W30010H-BG05BJ	R88M-W30010T-G05BJ	R88M-W30010T-BG05BJ
		1/9	R88M-W30010H-G09BJ	R88M-W30010H-BG09BJ	R88M-W30010T-G09BJ	R88M-W30010T-BG09BJ
		1/20	R88M-W30010H-G20BJ	R88M-W30010H-BG20BJ	R88M-W30010T-G20BJ	R88M-W30010T-BG20BJ
		1/29	R88M-W30010H-G29BJ	R88M-W30010H-BG29BJ	R88M-W30010T-G29BJ	R88M-W30010T-BG29BJ
		1/45	R88M-W30010H-G45BJ	R88M-W30010H-BG45BJ	R88M-W30010T-G45BJ	R88M-W30010T-BG45BJ
	600 W	1/5	R88M-W60010H-G05BJ	R88M-W60010H-BG05BJ	R88M-W60010T-G05BJ	R88M-W60010T-BG05BJ
		1/9	R88M-W60010H-G09BJ	R88M-W60010H-BG09BJ	R88M-W60010T-G09BJ	R88M-W60010T-BG09BJ
		1/20	R88M-W60010H-G20BJ	R88M-W60010H-BG20BJ	R88M-W60010T-G20BJ	R88M-W60010T-BG20BJ
		1/29	R88M-W60010H-G29BJ	R88M-W60010H-BG29BJ	R88M-W60010T-G29BJ	R88M-W60010T-BG29BJ
		1/45	R88M-W60010H-G45BJ	R88M-W60010H-BG45BJ	R88M-W60010T-G45BJ	R88M-W60010T-BG45BJ
	900 W	1/5	R88M-W90010H-G05BJ	R88M-W90010H-BG05BJ	R88M-W90010T-G05BJ	R88M-W90010T-BG05BJ
		1/9	R88M-W90010H-G09BJ	R88M-W90010H-BG09BJ	R88M-W90010T-G09BJ	R88M-W90010T-BG09BJ
		1/20	R88M-W90010H-G20BJ	R88M-W90010H-BG20BJ	R88M-W90010T-G20BJ	R88M-W90010T-BG20BJ
		1/29	R88M-W90010H-G29BJ	R88M-W90010H-BG29BJ	R88M-W90010T-G29BJ	R88M-W90010T-BG29BJ
		1/45	R88M-W90010H-G45BJ	R88M-W90010H-BG45BJ	R88M-W90010T-G45BJ	R88M-W90010T-BG45BJ
	1.2 kW	1/5	R88M-W1K210H-G05BJ	R88M-W1K210H-BG05BJ	R88M-W1K210T-G05BJ	R88M-W1K210T-BG05BJ
		1/9	R88M-W1K210H-G09BJ	R88M-W1K210H-BG09BJ	R88M-W1K210T-G09BJ	R88M-W1K210T-BG09BJ
		1/20	R88M-W1K210H-G20BJ	R88M-W1K210H-BG20BJ	R88M-W1K210T-G20BJ	R88M-W1K210T-BG20BJ
		1/29	R88M-W1K210H-G29BJ	R88M-W1K210H-BG29BJ	R88M-W1K210T-G29BJ	R88M-W1K210T-BG29BJ
		1/45	R88M-W1K210H-G45BJ	R88M-W1K210H-BG45BJ	R88M-W1K210T-G45BJ	R88M-W1K210T-BG45BJ
	2 kW	1/5	R88M-W2K010H-G05BJ	R88M-W2K010H-BG05BJ	R88M-W2K010T-G05BJ	R88M-W2K010T-BG05BJ
		1/9	R88M-W2K010H-G09BJ	R88M-W2K010H-BG09BJ	R88M-W2K010T-G09BJ	R88M-W2K010T-BG09BJ
		1/20	R88M-W2K010H-G20BJ	R88M-W2K010H-BG20BJ	R88M-W2K010T-G20BJ	R88M-W2K010T-BG20BJ
	3 kW	1/5	R88M-W3K010H-G05BJ	R88M-W3K010H-BG05BJ	R88M-W3K010T-G05BJ	R88M-W3K010T-BG05BJ
1/9		R88M-W3K010H-G09BJ	R88M-W3K010H-BG09BJ	R88M-W3K010T-G09BJ	R88M-W3K010T-BG09BJ	

• 1,500-r/min Servomotors

Specifications			Model			
			With incremental encoder		With absolute encoder	
			Without brake	With brake	Without brake	With brake
200 V	450 W	1/5	---	---	R88M-W45015T-G05BJ	R88M-W45015T-BG05BJ
		1/9	---	---	R88M-W45015T-G09BJ	R88M-W45015T-BG09BJ
		1/20	---	---	R88M-W45015T-G20BJ	R88M-W45015T-BG20BJ
		1/29	---	---	R88M-W45015T-G29BJ	R88M-W45015T-BG29BJ
		1/45	---	---	R88M-W45015T-G45BJ	R88M-W45015T-BG45BJ
	850 W	1/5	---	---	R88M-W85015T-G05BJ	R88M-W85015T-BG05BJ
		1/9	---	---	R88M-W85015T-G09BJ	R88M-W85015T-BG09BJ
		1/20	---	---	R88M-W85015T-G20BJ	R88M-W85015T-BG20BJ
		1/29	---	---	R88M-W85015T-G29BJ	R88M-W85015T-BG29BJ
		1/45	---	---	R88M-W85015T-G45BJ	R88M-W85015T-BG45BJ
	1.3 kW	1/5	---	---	R88M-W1K315T-G05BJ	R88M-W1K315T-BG05BJ
		1/9	---	---	R88M-W1K315T-G09BJ	R88M-W1K315T-BG09BJ
		1/20	---	---	R88M-W1K315T-G20BJ	R88M-W1K315T-BG20BJ
		1/29	---	---	R88M-W1K315T-G29BJ	R88M-W1K315T-BG29BJ
		1/45	---	---	R88M-W1K315T-G45BJ	R88M-W1K315T-BG45BJ
	1.8 kW	1/5	---	---	R88M-W1K815T-G05BJ	R88M-W1K815T-BG05BJ
		1/9	---	---	R88M-W1K815T-G09BJ	R88M-W1K815T-BG09BJ
		1/20	---	---	R88M-W1K815T-G20BJ	R88M-W1K815T-BG20BJ
		1/29	---	---	R88M-W1K815T-G29BJ	R88M-W1K815T-BG29BJ
	2.9 kW	1/5	---	---	R88M-W2K915T-G05BJ	R88M-W2K915T-BG05BJ
		1/9	---	---	R88M-W2K915T-G09BJ	R88M-W2K915T-BG09BJ
		1/20	---	---	R88M-W2K915T-G20BJ	R88M-W2K915T-BG20BJ
	4.4 kW	1/5	---	---	R88M-W4K415T-G05BJ	R88M-W4K415T-BG05BJ
		1/9	---	---	R88M-W4K415T-G09BJ	R88M-W4K415T-BG09BJ

- Servomotors with Economy Gears (Straight Shaft with Key)
- 3,000-r/min Servomotors

Specifications			Model				
			With incremental encoder		With absolute encoder		
			Without brake	With brake	Without brake	With brake	
100 V	100 W	1/5	R88M-W10030L-G05CJ	R88M-W10030L-BG05CJ	R88M-W10030S-G05CJ	R88M-W10030S-BG05CJ	
		1/9	R88M-W10030L-G09CJ	R88M-W10030L-BG09CJ	R88M-W10030S-G09CJ	R88M-W10030S-BG09CJ	
		1/15	R88M-W10030L-G15CJ	R88M-W10030L-BG15CJ	R88M-W10030S-G15CJ	R88M-W10030S-BG15CJ	
		1/25	R88M-W10030L-G25CJ	R88M-W10030L-BG25CJ	R88M-W10030S-G25CJ	R88M-W10030S-BG25CJ	
	200 W	1/5	R88M-W20030L-G05CJ	R88M-W20030L-BG05CJ	R88M-W20030S-G05CJ	R88M-W20030S-BG05CJ	
		1/9	R88M-W20030L-G09CJ	R88M-W20030L-BG09CJ	R88M-W20030S-G09CJ	R88M-W20030S-BG09CJ	
		1/15	R88M-W20030L-G15CJ	R88M-W20030L-BG15CJ	R88M-W20030S-G15CJ	R88M-W20030S-BG15CJ	
		1/25	R88M-W20030L-G25CJ	R88M-W20030L-BG25CJ	R88M-W20030S-G25CJ	R88M-W20030S-BG25CJ	
	200 V	100 W	1/5	R88M-W10030H-G05CJ	R88M-W10030H-BG05CJ	R88M-W10030T-G05CJ	R88M-W10030T-BG05CJ
			1/9	R88M-W10030H-G09CJ	R88M-W10030H-BG09CJ	R88M-W10030T-G09CJ	R88M-W10030T-BG09CJ
			1/15	R88M-W10030H-G15CJ	R88M-W10030H-BG15CJ	R88M-W10030T-G15CJ	R88M-W10030T-BG15CJ
			1/25	R88M-W10030H-G25CJ	R88M-W10030H-BG25CJ	R88M-W10030T-G25CJ	R88M-W10030T-BG25CJ
200 W		1/5	R88M-W20030H-G05CJ	R88M-W20030H-BG05CJ	R88M-W20030T-G05CJ	R88M-W20030T-BG05CJ	
		1/9	R88M-W20030H-G09CJ	R88M-W20030H-BG09CJ	R88M-W20030T-G09CJ	R88M-W20030T-BG09CJ	
		1/15	R88M-W20030H-G15CJ	R88M-W20030H-BG15CJ	R88M-W20030T-G15CJ	R88M-W20030T-BG15CJ	
		1/25	R88M-W20030H-G25CJ	R88M-W20030H-BG25CJ	R88M-W20030T-G25CJ	R88M-W20030T-BG25CJ	
400 W		1/5	R88M-W40030H-G05CJ	R88M-W40030H-BG05CJ	R88M-W40030T-G05CJ	R88M-W40030T-BG05CJ	
		1/9	R88M-W40030H-G09CJ	R88M-W40030H-BG09CJ	R88M-W40030T-G09CJ	R88M-W40030T-BG09CJ	
		1/15	R88M-W40030H-G15CJ	R88M-W40030H-BG15CJ	R88M-W40030T-G15CJ	R88M-W40030T-BG15CJ	
		1/25	R88M-W40030H-G25CJ	R88M-W40030H-BG25CJ	R88M-W40030T-G25CJ	R88M-W40030T-BG25CJ	
750 W		1/5	R88M-W75030H-G05CJ	R88M-W75030H-BG05CJ	R88M-W75030T-G05CJ	R88M-W75030T-BG05CJ	
		1/9	R88M-W75030H-G09CJ	R88M-W75030H-BG09CJ	R88M-W75030T-G09CJ	R88M-W75030T-BG09CJ	
		1/15	R88M-W75030H-G15CJ	R88M-W75030H-BG15CJ	R88M-W75030T-G15CJ	R88M-W75030T-BG15CJ	
		1/25	R88M-W75030H-G25CJ	R88M-W75030H-BG25CJ	R88M-W75030T-G25CJ	R88M-W75030T-BG25CJ	

• 3,000-r/min Flat-style Servomotors

Specifications			Model			
			With incremental encoder		With absolute encoder	
			Without brake	With brake	Without brake	With brake
100 V	100 W	1/5	R88M-WP10030L-G05CJ	R88M-WP10030L-BG05CJ	R88M-WP10030S-G05CJ	R88M-WP10030S-BG05CJ
		1/9	R88M-WP10030L-G09CJ	R88M-WP10030L-BG09CJ	R88M-WP10030S-G09CJ	R88M-WP10030S-BG09CJ
		1/15	R88M-WP10030L-G15CJ	R88M-WP10030L-BG15CJ	R88M-WP10030S-G15CJ	R88M-WP10030S-BG15CJ
		1/25	R88M-WP10030L-G25CJ	R88M-WP10030L-BG25CJ	R88M-WP10030S-G25CJ	R88M-WP10030S-BG25CJ
	200 W	1/5	R88M-WP20030L-G05CJ	R88M-WP20030L-BG05CJ	R88M-WP20030S-G05CJ	R88M-WP20030S-BG05CJ
		1/9	R88M-WP20030L-G09CJ	R88M-WP20030L-BG09CJ	R88M-WP20030S-G09CJ	R88M-WP20030S-BG09CJ
		1/15	R88M-WP20030L-G15CJ	R88M-WP20030L-BG15CJ	R88M-WP20030S-G15CJ	R88M-WP20030S-BG15CJ
		1/25	R88M-WP20030L-G25CJ	R88M-WP20030L-BG25CJ	R88M-WP20030S-G25CJ	R88M-WP20030S-BG25CJ
200 V	100 W	1/5	R88M-WP10030H-G05CJ	R88M-WP10030H-BG05CJ	R88M-WP10030T-G05CJ	R88M-WP10030T-BG05CJ
		1/9	R88M-WP10030H-G09CJ	R88M-WP10030H-BG09CJ	R88M-WP10030T-G09CJ	R88M-WP10030T-BG09CJ
		1/15	R88M-WP10030H-G15CJ	R88M-WP10030H-BG15CJ	R88M-WP10030T-G15CJ	R88M-WP10030T-BG15CJ
		1/25	R88M-WP10030H-G25CJ	R88M-WP10030H-BG25CJ	R88M-WP10030T-G25CJ	R88M-WP10030T-BG25CJ
	200 W	1/5	R88M-WP20030H-G05CJ	R88M-WP20030H-BG05CJ	R88M-WP20030T-G05CJ	R88M-WP20030T-BG05CJ
		1/9	R88M-WP20030H-G09CJ	R88M-WP20030H-BG09CJ	R88M-WP20030T-G09CJ	R88M-WP20030T-BG09CJ
		1/15	R88M-WP20030H-G15CJ	R88M-WP20030H-BG15CJ	R88M-WP20030T-G15CJ	R88M-WP20030T-BG15CJ
		1/25	R88M-WP20030H-G25CJ	R88M-WP20030H-BG25CJ	R88M-WP20030T-G25CJ	R88M-WP20030T-BG25CJ
	400 W	1/5	R88M-WP40030H-G05CJ	R88M-WP40030H-BG05CJ	R88M-WP40030T-G05CJ	R88M-WP40030T-BG05CJ
		1/9	R88M-WP40030H-G09CJ	R88M-WP40030H-BG09CJ	R88M-WP40030T-G09CJ	R88M-WP40030T-BG09CJ
		1/15	R88M-WP40030H-G15CJ	R88M-WP40030H-BG15CJ	R88M-WP40030T-G15CJ	R88M-WP40030T-BG15CJ
		1/25	R88M-WP40030H-G25CJ	R88M-WP40030H-BG25CJ	R88M-WP40030T-G25CJ	R88M-WP40030T-BG25CJ
	750 W	1/5	R88M-WP75030H-G05CJ	R88M-WP75030H-BG05CJ	R88M-WP75030T-G05CJ	R88M-WP75030T-BG05CJ
		1/9	R88M-WP75030H-G09CJ	R88M-WP75030H-BG09CJ	R88M-WP75030T-G09CJ	R88M-WP75030T-BG09CJ
		1/15	R88M-WP75030H-G15CJ	R88M-WP75030H-BG15CJ	R88M-WP75030T-G15CJ	R88M-WP75030T-BG15CJ
		1/25	R88M-WP75030H-G25CJ	R88M-WP75030H-BG25CJ	R88M-WP75030T-G25CJ	R88M-WP75030T-BG25CJ

2-2 Servo Driver and Servomotor Combinations

The tables in this section show the possible combinations of OMNUC W-series Servo Drivers and Servomotors. The boxes (-□) at the ends of the model numbers are for options such as shaft type, brake, waterproofing, decelerator, and so on.

■ 3,000-r/min Servomotors and Servo Drivers

Voltage	Servomotor			Servo Driver
	Rated output	With incremental encoder	With absolute encoder	
100 V	30 W	R88M-W03030L-□	R88M-W03030S-□	R88D-WTA3HL
	50 W	R88M-W05030L-□	R88M-W05030S-□	R88D-WTA5HL
	100 W	R88M-W10030L-□	R88M-W10030S-□	R88D-WT01HL
	200 W	R88M-W20030L-□	R88M-W20030S-□	R88D-WT02HL
200 V	30 W	R88M-W03030H-□	R88M-W03030T-□	R88D-WTA3H
	50 W	R88M-W05030H-□	R88M-W05030T-□	R88D-WTA5H
	100 W	R88M-W10030H-□	R88M-W10030T-□	R88D-WT01H
	200 W	R88M-W20030H-□	R88M-W20030T-□	R88D-WT02H
	400 W	R88M-W40030H-□	R88M-W40030T-□	R88D-WT04H
	750 W	R88M-W75030H-□	R88M-W75030T-□	R88D-WT08H
	1 kW	R88M-W1K030H-□	R88M-W1K030T-□	R88D-WT10H
	1.5 kW	R88M-W1K530H-□	R88M-W1K530T-□	R88D-WT15H
	2 kW	R88M-W2K030H-□	R88M-W2K030T-□	R88D-WT20H
	3 kW	R88M-W3K030H-□	R88M-W3K030T-□	R88D-WT30H
	4 kW	R88M-W4K030H-□	R88M-W4K030T-□	R88D-WT50H
	5 kW	R88M-W5K030H-□	R88M-W5K030T-□	R88D-WT50H

■ 3,000-r/min Flat-style Servomotors and Servo Drivers

Voltage	Servomotor			Servo Driver
	Rated output	With incremental encoder	With absolute encoder	
100 V	100 W	R88M-WP10030L-□	R88M-WP10030S-□	R88D-WT01HL
	200 W	R88M-WP20030L-□	R88M-WP20030S-□	R88D-WT02HL
200 V	100 W	R88M-WP10030H-□	R88M-WP10030T-□	R88D-WT01H
	200 W	R88M-WP20030H-□	R88M-WP20030T-□	R88D-WT02H
	400 W	R88M-WP40030H-□	R88M-WP40030T-□	R88D-WT04H
	750 W	R88M-WP75030H-□	R88M-WP75030T-□	R88D-WT08H
	1.5 kW	R88M-WP1K530H-□	R88M-WP1K530T-□	R88D-WT15H

■ 1,000-r/min Servomotors and Servo Drivers

Voltage	Servomotor			Servo Driver
	Rated output	With incremental encoder	With absolute encoder	
200 V	300 W	R88M-W30010H-□	R88M-W30010T-□	R88D-WT05H
	600 W	R88M-W60010H-□	R88M-W60010T-□	R88D-WT08H
	900 W	R88M-W90010H-□	R88M-W90010T-□	R88D-WT10H
	1.2 kW	R88M-W1K210H-□	R88M-W1K210T-□	R88D-WT15H
	2 kW	R88M-W2K010H-□	R88M-W2K010T-□	R88D-WT20H
	3 kW	R88M-W3K010H-□	R88M-W3K010T-□	R88D-WT30H
	4 kW	R88M-W4K010H-□	R88M-W4K010T-□	R88D-WT50H
	5.5 kW	R88M-W5K510H-□	R88M-W5K510T-□	R88D-WT60H

■ 1,500-r/min Servomotors and Servo Drivers

Voltage	Servomotor			Servo Driver
	Rated output	With incremental encoder	With absolute encoder	
200 V	450 W	---	R88M-W45015T-□	R88D-WT05H
	850 W	---	R88M-W85015T-□	R88D-WT10H
	1.3 kW	---	R88M-W1K315T-□	R88D-WT15H
	1.8 kW	---	R88M-W1K815T-□	R88D-WT20H
	2.9 kW	---	R88M-W2K915T-□	R88D-WT30H
	4.4 kW	---	R88M-W4K415T-□	R88D-WT50H
	5.5 kW	---	R88M-W5K515T-□	R88D-WT60H
	7.5 kW	---	R88M-W7K515T-□	R88D-WT75H
	11 kW	---	R88M-W11K015T-□	R88D-WT150H
	15 kW	---	R88M-W15K015T-□	R88D-WT150H

2-3 External and Mounted Dimensions

Dimensions are shown in millimeters.

2-3-1 AC Servo Drivers

- Single-phase 100 V: R88D-WTA3HL/-WTA5HL/-WT01HL (30 to 100 W)
Single-phase 200 V: R88D-WTA3H/-WTA5H/-WT01H/-WT02H (30 to 200 W)

• Wall Mounting

External dimensions

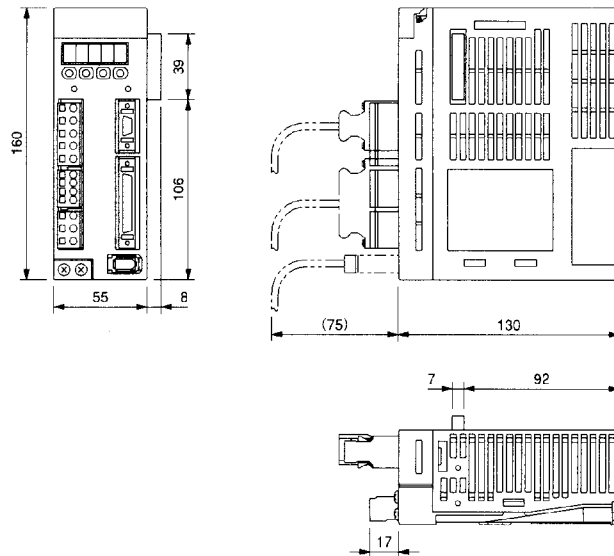

Mounted dimensions

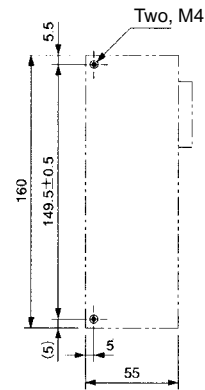

• Front Panel Mounting (Using Mounting Brackets)

External dimensions

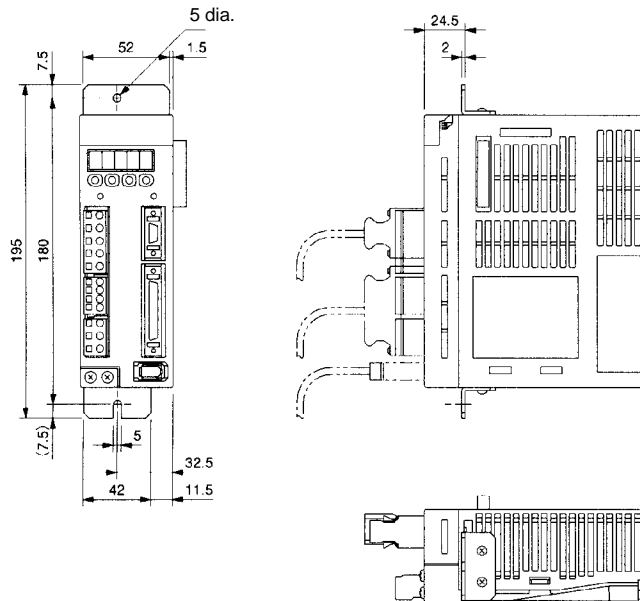

Mounted dimensions

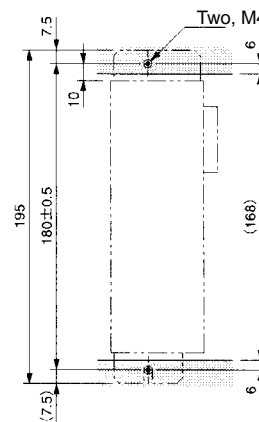

- Single-phase 100 V: R88D-WT02HL (200 W)
- Single-phase 200 V: R88D-WT04H (400 W)

● Wall Mounting

External dimensions

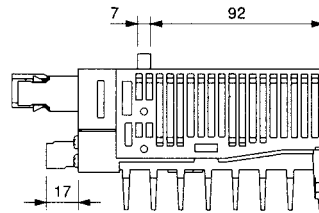
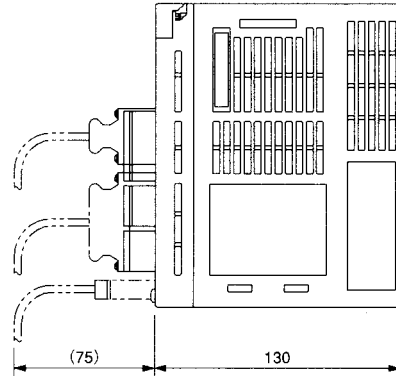
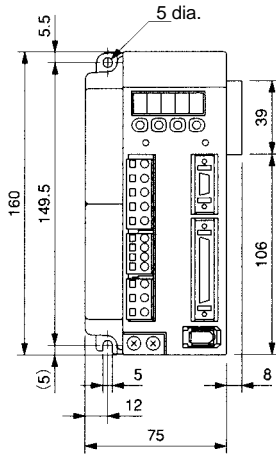

Mounted dimensions

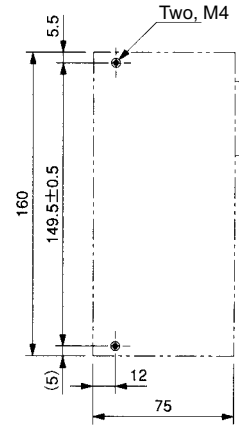

● Front Panel Mounting (Using Mounting Brackets)

External dimensions

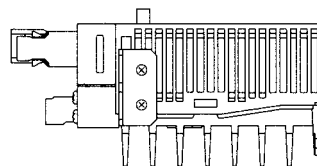
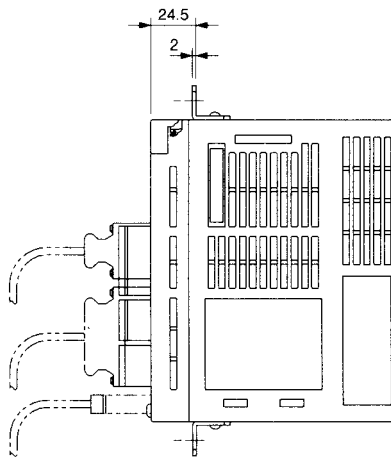
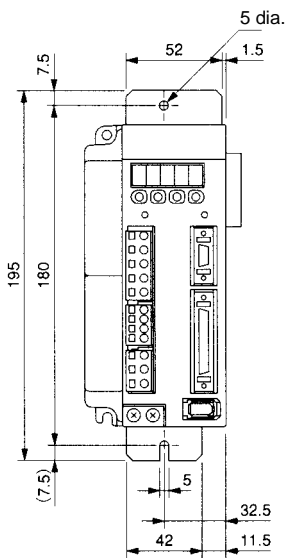

Mounted dimensions

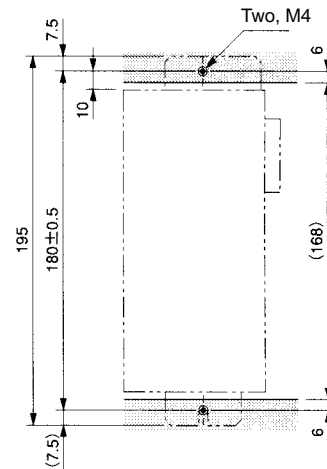

■ Three-phase 200 V: R88D-WT05H/-WT08H/-WT10H (500 W to 1 kW)

● Wall Mounting

External dimensions

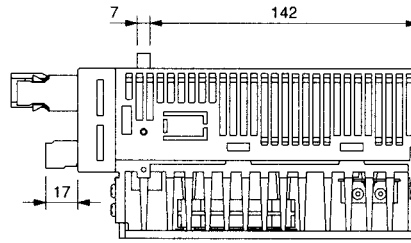
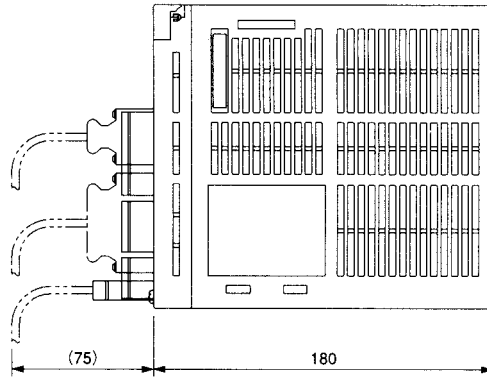
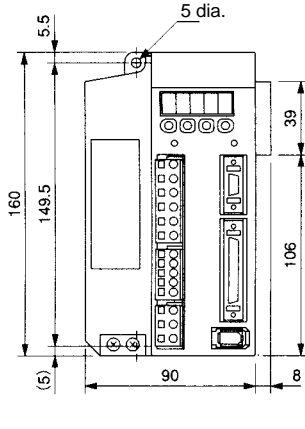

Mounted dimensions

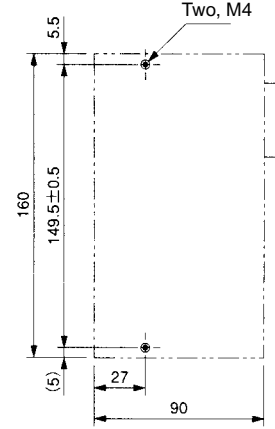

● Front Panel Mounting (Using Mounting Brackets)

External dimensions

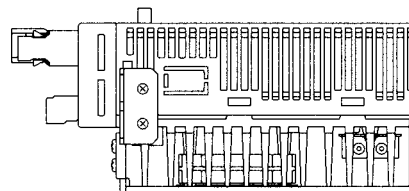
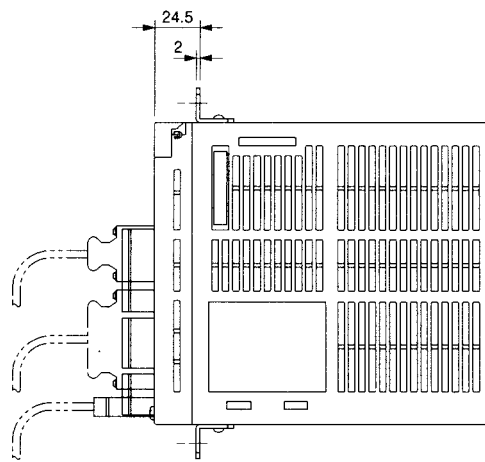
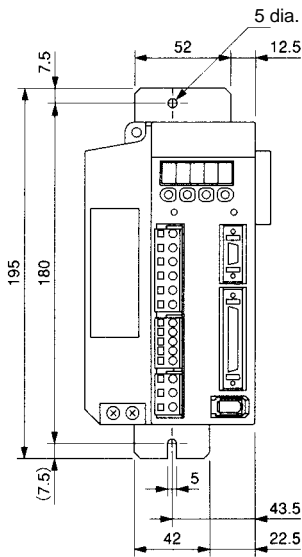

Mounted dimensions

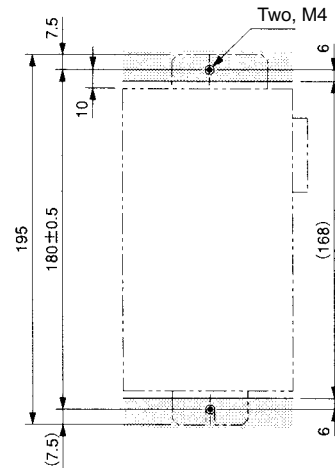

■ Three-phase 200 V: R88D-WT15H (1.5 kW)

● Wall Mounting

External dimensions

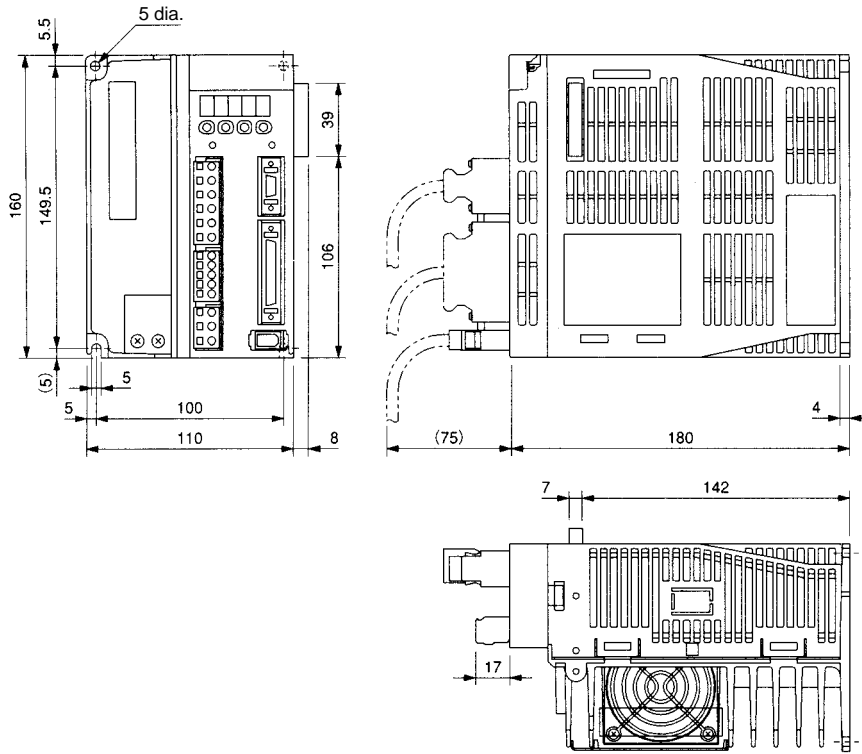

Mounted dimensions

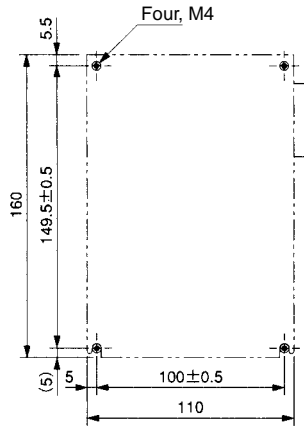

● Front Panel Mounting (Using Mounting Brackets)

External dimensions

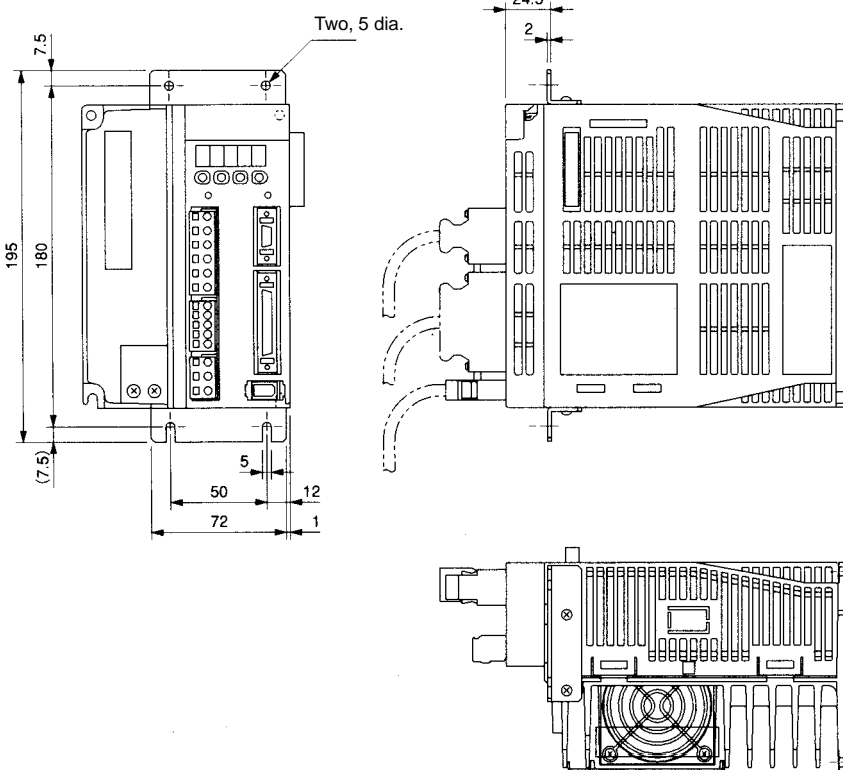

Mounted dimensions

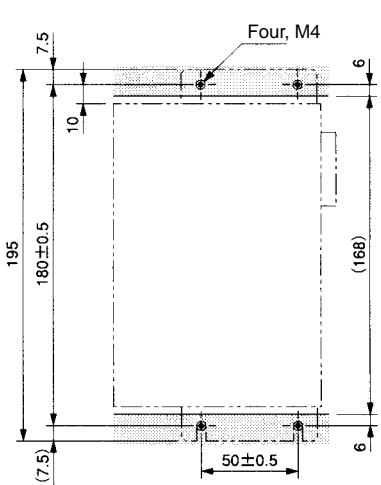

■ Three-phase 200 V: R88D-WT20H/-WT30H (2 to 3 kW)

● Wall Mounting

External dimensions

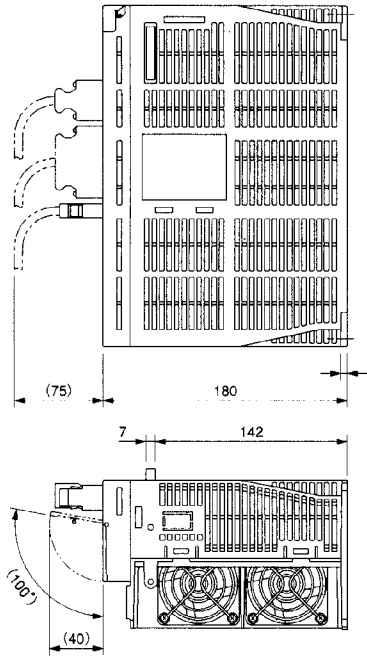
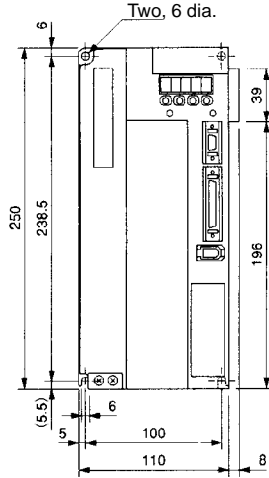

Mounted dimensions

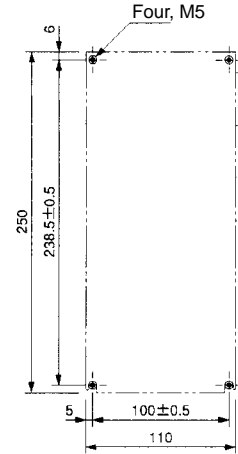

● Front Panel Mounting (Using Mounting Brackets)

External dimensions

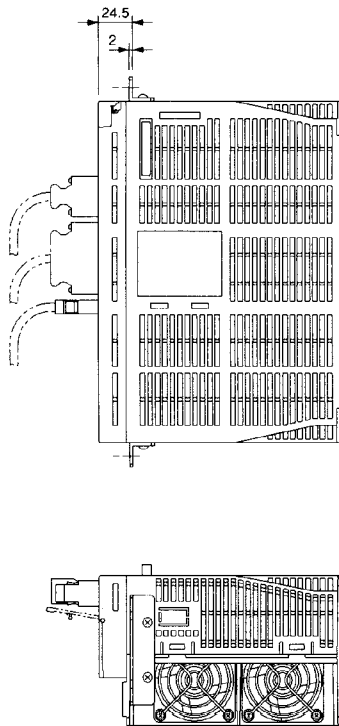
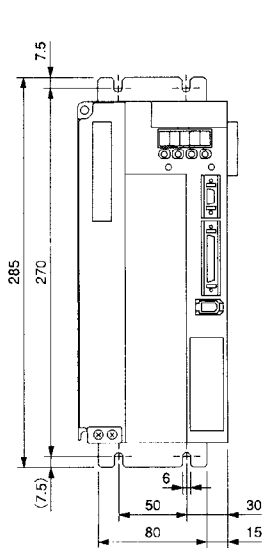

Mounted dimensions

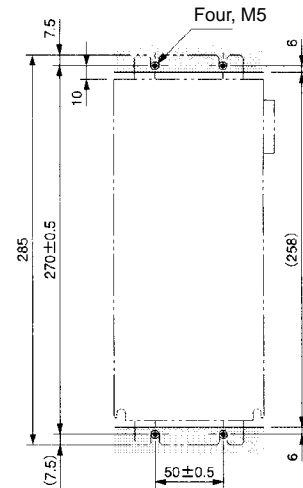

■ Three-phase 200 V: R88D-WT50H (5 kW)

● Wall Mounting

External dimensions

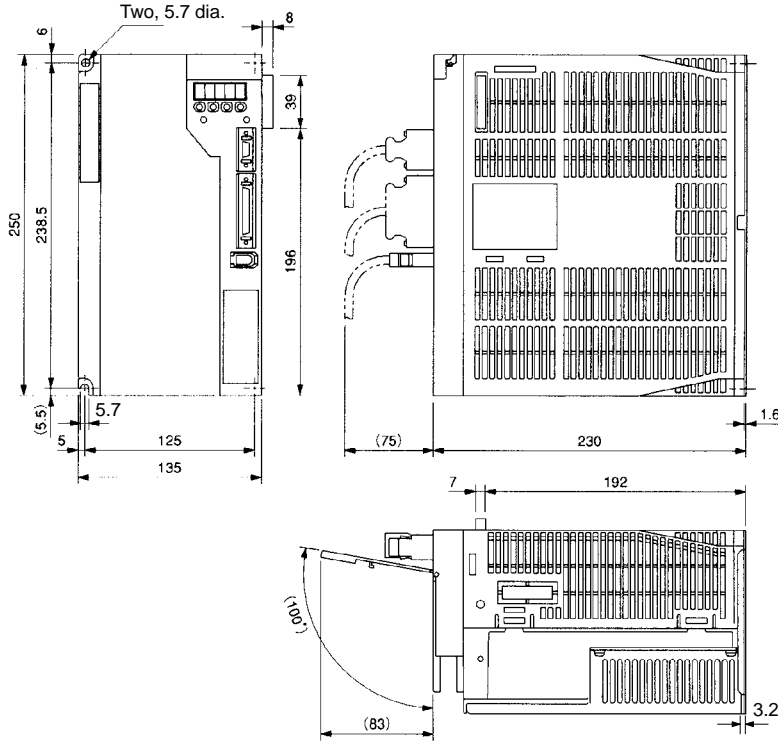

Mounted dimensions

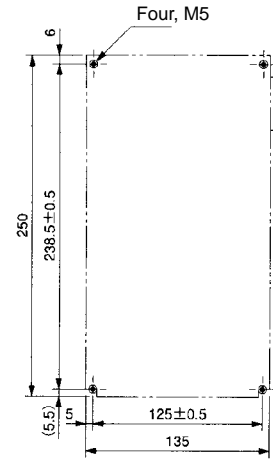

● Front Panel Mounting (Using Mounting Brackets)

External dimensions

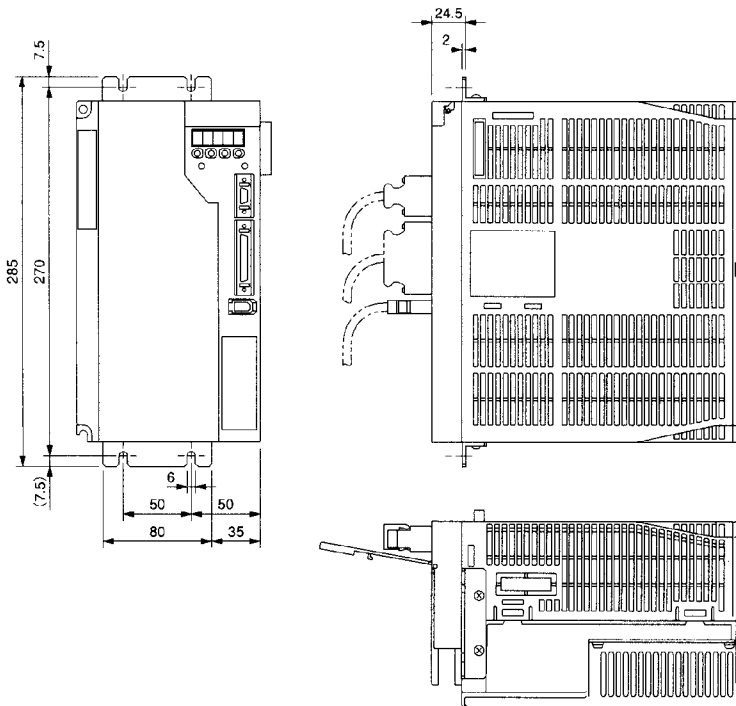

Mounted dimensions

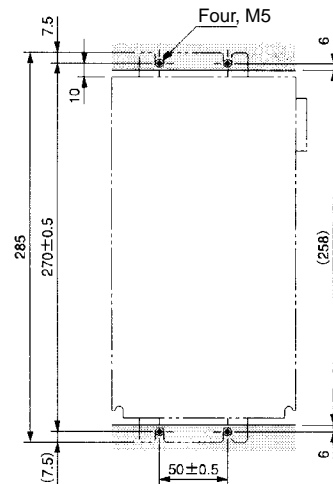

■ Three-phase 200 V: R88D-WT60H/-WT75H (6 to 7.5 kW)

● Wall Mounting

External dimensions

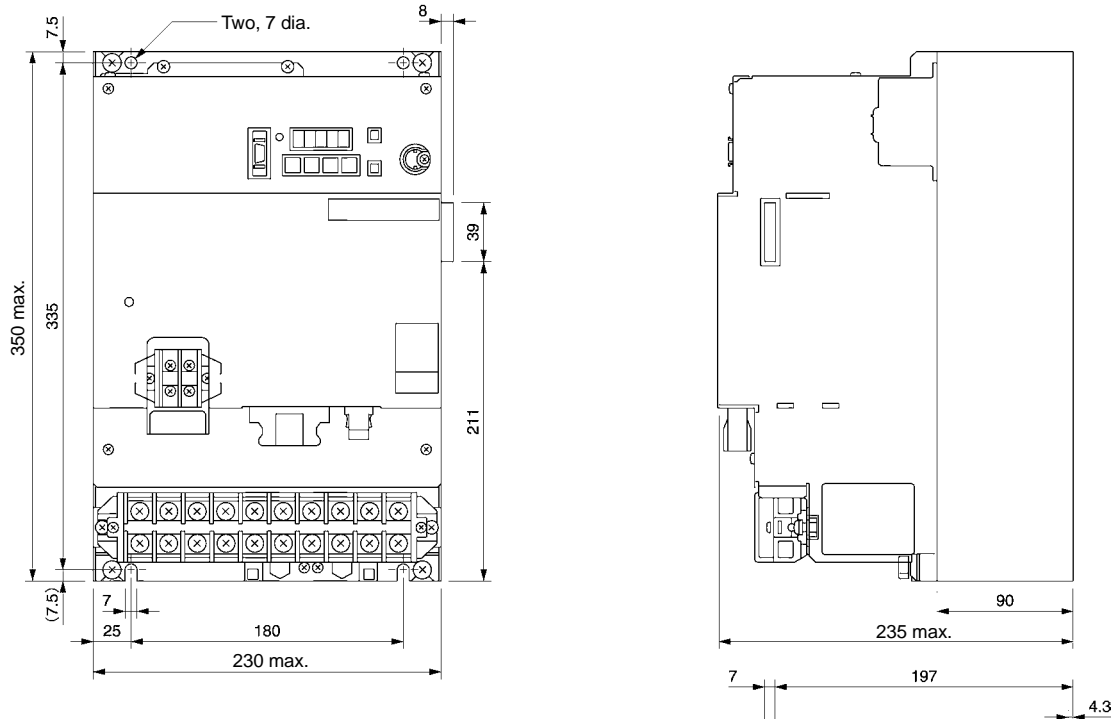

Mounting dimensions

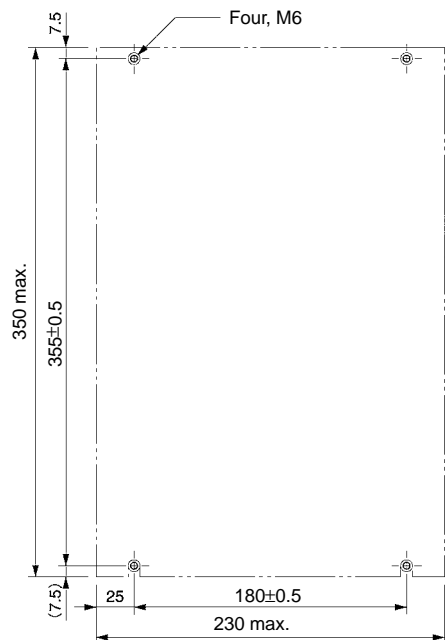

■ Three-phase 200 V: R88D-WT150H (15 kW)

● Wall Mounting

External dimensions

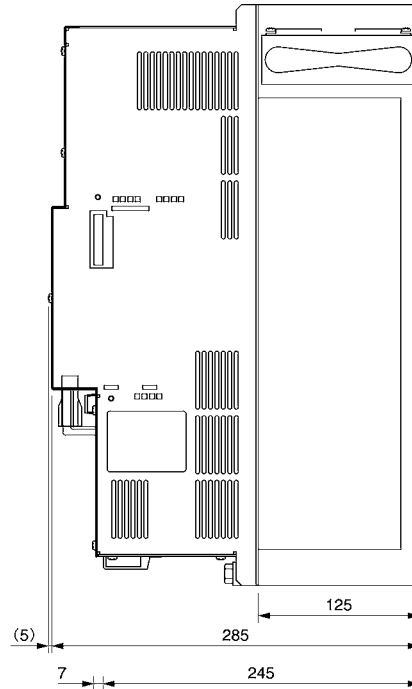
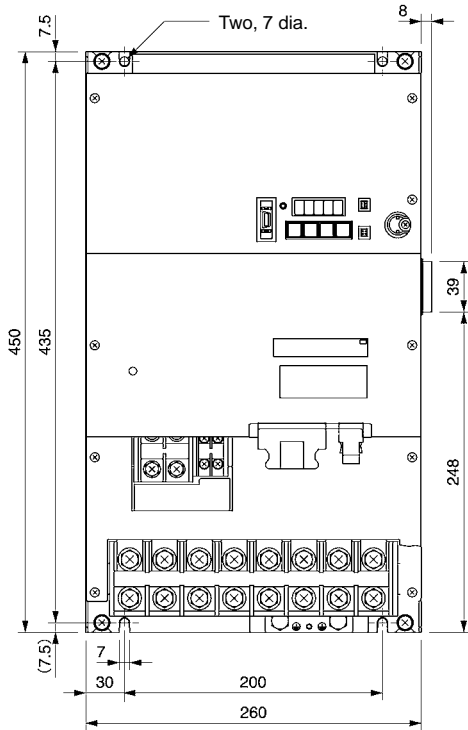

Mounting dimensions

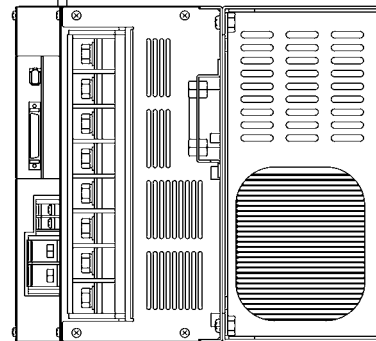
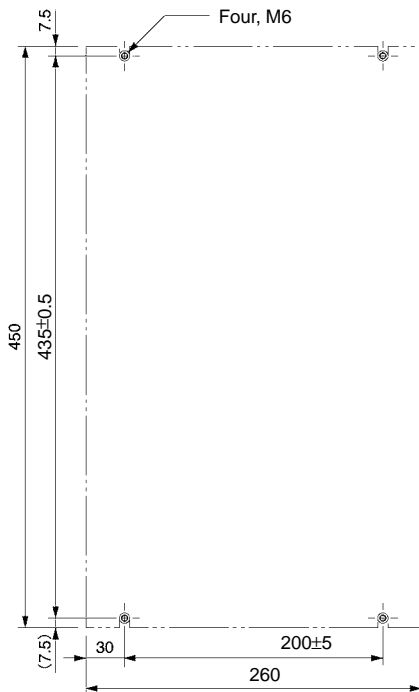

2-3-2 Parameter Units

■ Hand-held Parameter Unit: R88A-PR02W

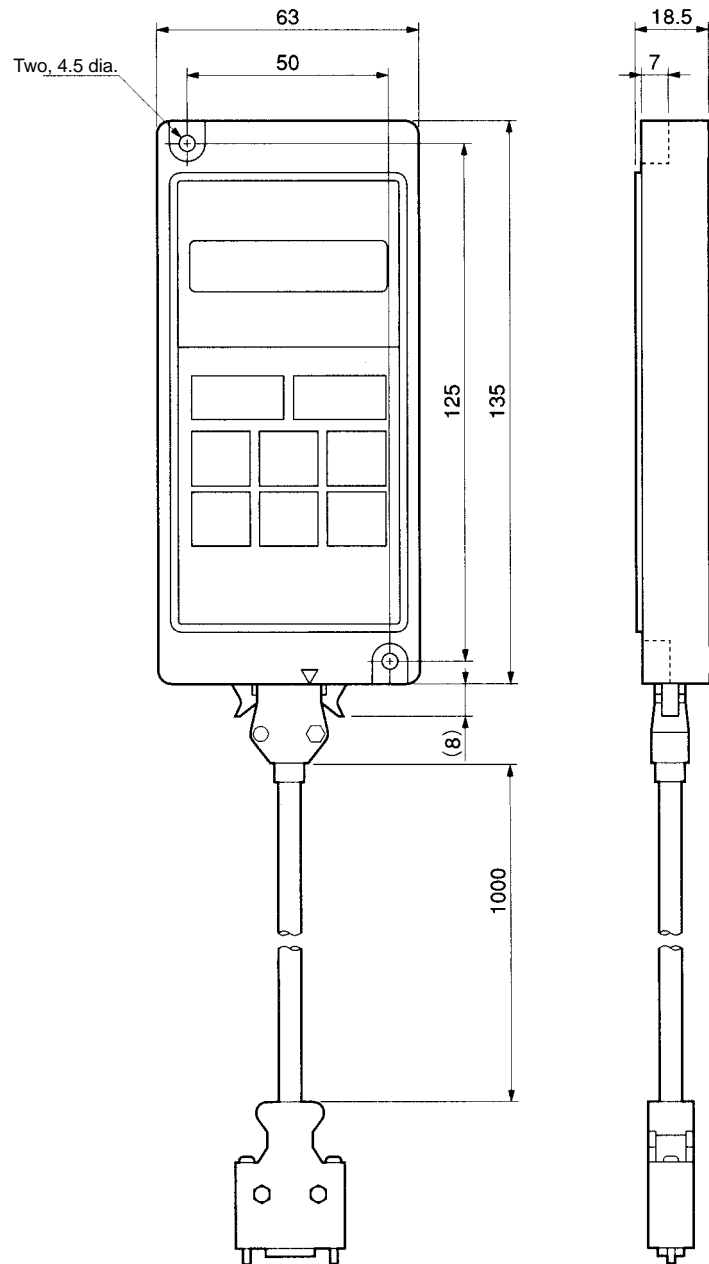

2-3-3 AC Servomotors

■ 3,000-r/min Servomotors without a Brake

- 100 V AC: 30 W/50 W/100 W
R88M-W03030L(-S1)/-W05030L(-S1)/-W10030L(-S1) [Incremental]
R88M-W03030S(-S1)/-W05030S(-S1)/-W10030S(-S1) [Absolute]
- 200 V AC: 30 W/50 W/100 W
R88M-W03030H(-S1)/-W05030H(-S1)/-W10030H(-S1) [Incremental]
R88M-W03030T(-S1)/-W05030T(-S1)/-W10030T(-S1) [Absolute]

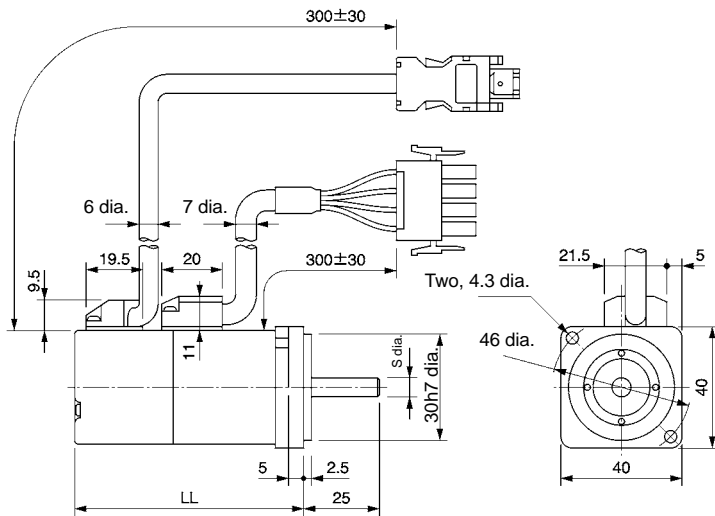

Dimensions of shaft end with key (-S1)

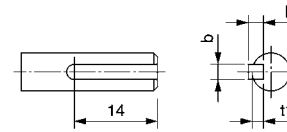

Dimensions of shaft end with key and tap (-S2)

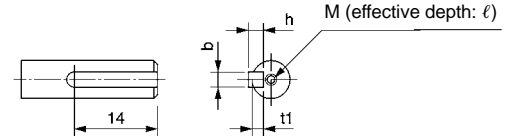

Model	Dimensions (mm)						
	LL	S	b	h	t1	M	ℓ
R88M-W03030□-□	69.5	6h6	2	2	1.2	M2.5	5
R88M-W05030□-□	77	6h6	2	2	1.2		
R88M-W10030□-□	94.5	8h6	3	3	1.8	M3	6

■ 3,000-r/min Servomotors with a Brake

- 100 V AC: 30 W/50 W/100 W
 R88M-W03030L-B(S1)/-W05030L-B(S1)/-W10030L-B(S1) [Incremental]
 R88M-W03030S-B(S1)/-W05030S-B(S1)/-W10030S-B(S1) [Absolute]
- 200 V AC: 30 W/50 W/100 W
 R88M-W03030H-B(S1)/-W05030H-B(S1)/-W10030H-B(S1) [Incremental]
 R88M-W03030T-B(S1)/-W05030T-B(S1)/-W10030T-B(S1) [Absolute]

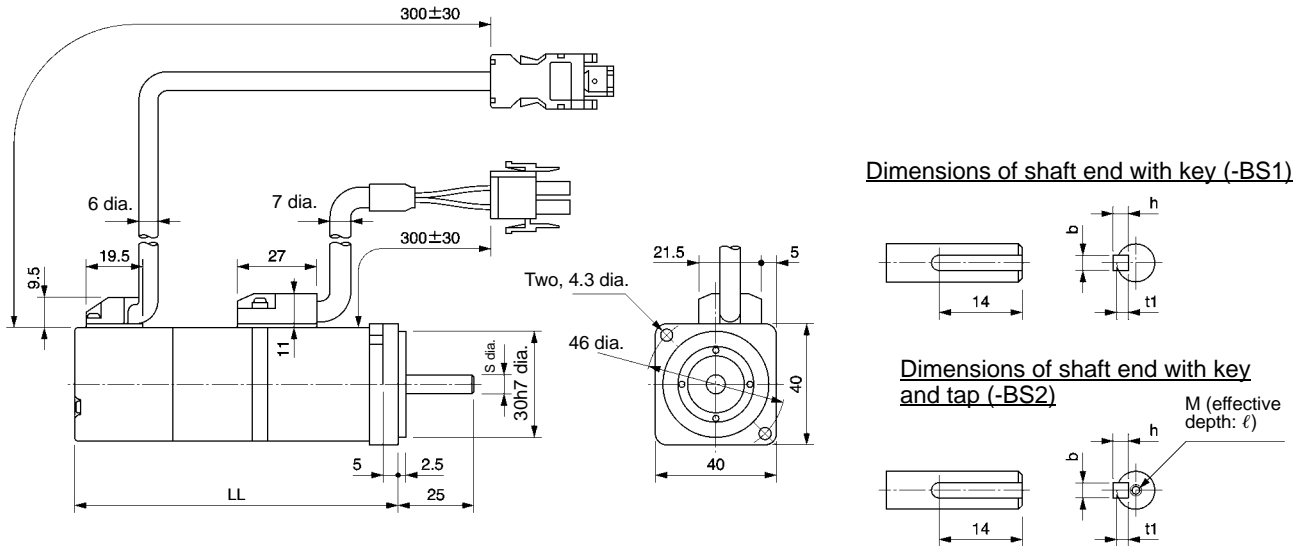

Model	Dimensions (mm)						
	LL	S	b	h	t1	M	ℓ
R88M-W03030□-B□	101	6h6	2	2	1.2	M2.5	5
R88M-W05030□-B□	108.5	6h6	2	2	1.2		
R88M-W10030□-B□	135	8h6	3	3	1.8	M3	6

■ 3,000-r/min Servomotors without a Brake

- 100 V AC: 200 W
R88M-W20030L(-S1) [Incremental]
R88M-W20030S(-S1) [Absolute]

- 200 V AC: 200 W/400 W/750 W
R88M-W20030H(-S1)/-W40030H(-S1)/-W75030H(-S1) [Incremental]
R88M-W20030T(-S1)/-W40030T(-S1)/-W75030T(-S1) [Absolute]

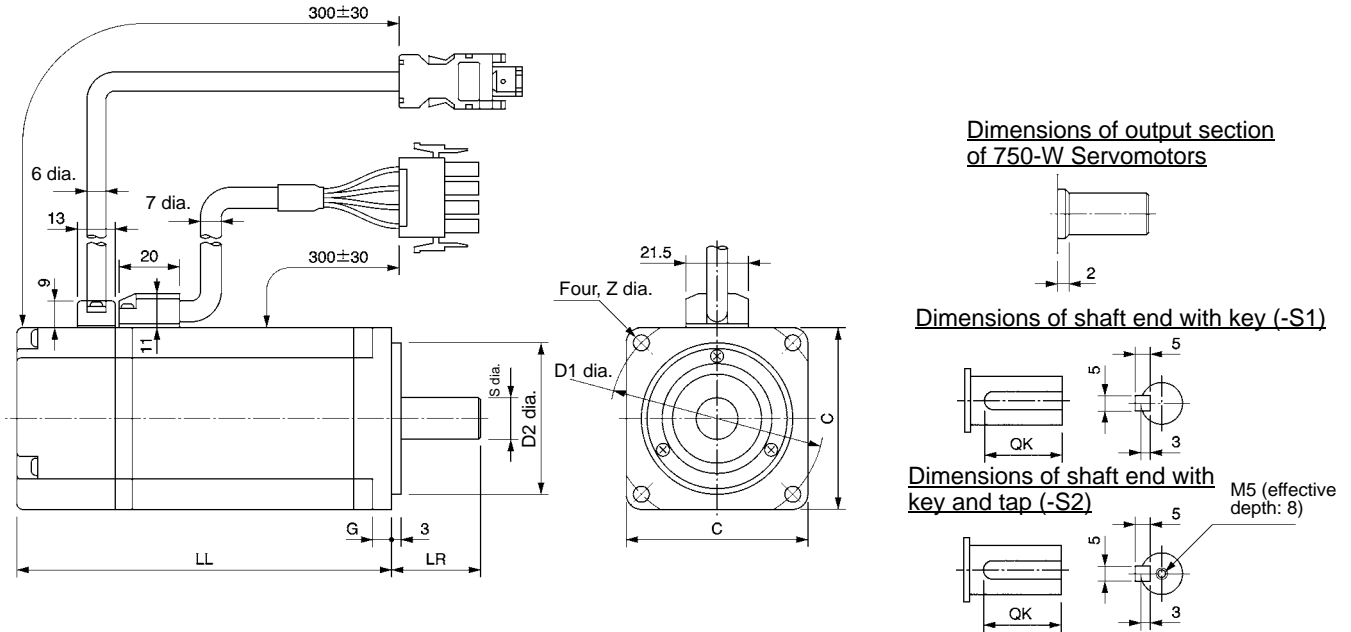

Model	Dimensions (mm)								
	LL	LR	C	D1	D2	G	Z	S	QK
R88M-W20030□-□	96.5	30	60	70	50h7	6	5.5	14h6	20
R88M-W40030□-□	124.5	30	60	70	50h7	6	5.5	14h6	20
R88M-W75030□-□	145	40	80	90	70h7	8	7	16h6	30

■ 3,000-r/min Servomotors with a Brake

- 100 V AC: 200 W
R88M-W20030L-B(S1) [Incremental]
R88M-W20030S-B(S1) [Absolute]
- 200 V AC: 200 W/400 W/750 W
R88M-W20030H-B(S1)/-W40030H-B(S1)/-W75030H-B(S1) [Incremental]
R88M-W20030T-B(S1)/-W40030T-B(S1)/-W75030T-B(S1) [Absolute]

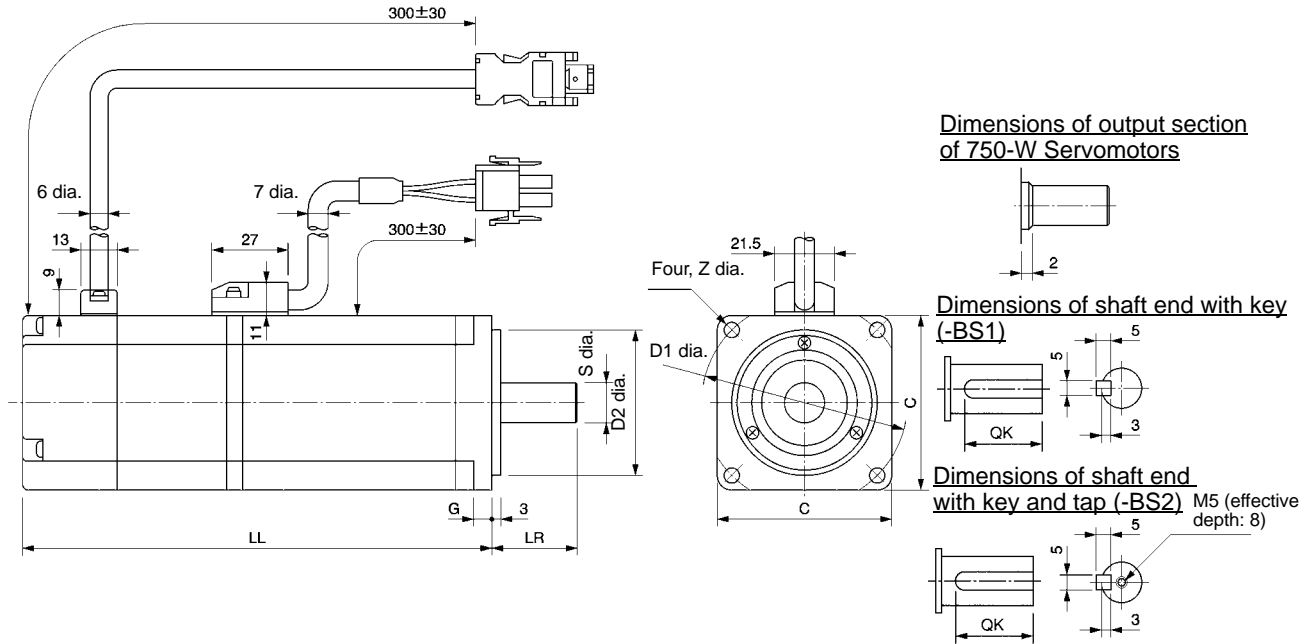

Model	Dimensions (mm)								
	LL	LR	C	D1	D2	G	Z	S	QK
R88M-W20030□-B□	136	30	60	70	50h7	6	5.5	14h6	20
R88M-W40030□-B□	164	30	60	70	50h7	6	5.5	14h6	20
R88M-W75030□-B□	189.5	40	80	90	70h7	8	7	16h6	30

■ 3,000-r/min Servomotors without a Brake

- 200 V AC: 1 kW/1.5 kW/2 kW/3 kW/4.0 kW/5.0 kW
R88M-W1K030H(-S2)/-W1K5030H(-S2)/-W2K030H(-S2)/-W3K030H(-S2)/
-W4K030H(-S2)/-W5K030H(-S2) [Incremental]
R88M-W1K030T(-S2)/-W1K5030T(-S2)/-W2K030T(-S2)/-W3K030T(-S2)/
-W4K030T(-S2)/-W5K030T(-S2) [Absolute]

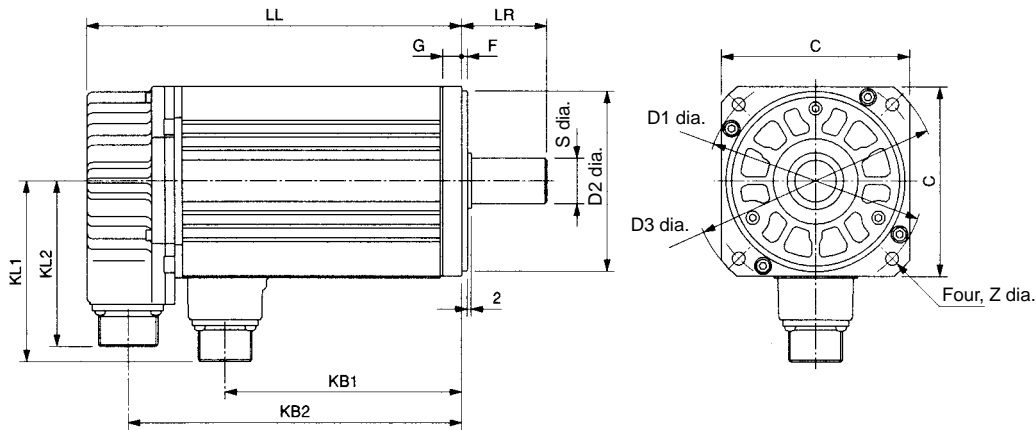

Dimensions of shaft end with key (-S2)

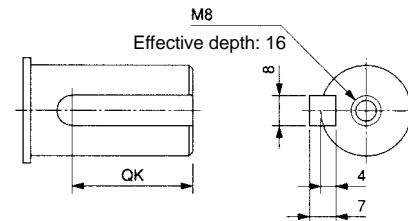

Model	Dimensions (mm)														
	LL	LR	KB1	KB2	KL1	KL2	C	D1	D2	D3	F	G	Z	S	QK
R88M-W1K030□-□	148	45	76	128	96	88	100	115	95h7	130	3	10	7	24h6	32
R88M-W1K530□-□	175		102	154											
R88M-W2K030□-□	198		125	177											
R88M-W3K030□-□	199	63	124	178	114	88	130	145	110h7	165	6	12	9	28h6	50
R88M-W4K030□-□	236		161	215											
R88M-W5K030□-□	276		201	255											

Note The external dimensions are the same for IP67 (waterproof) models (-O□).

■ 3,000-r/min Servomotors with a Brake

- 200 V AC: 1 kW/1.5 kW/2 kW/3 kW/4.0 kW/5.0 kW
R88M-W1K030H-B(S2)/-W1K5030H-B(S2)/-W2K030H-B(S2)/-W3K030H-B(S2)/
-W4K030H-B(S2)/-W5K030H-B(S2) [Incremental]
R88M-W1K030T-B(S2)/-W1K5030T-B(S2)/-W2K030T-B(S2)/-W3K030T-B(S2)/
-W4K030T-B(S2)/-W5K030T-B(S2) [Absolute]

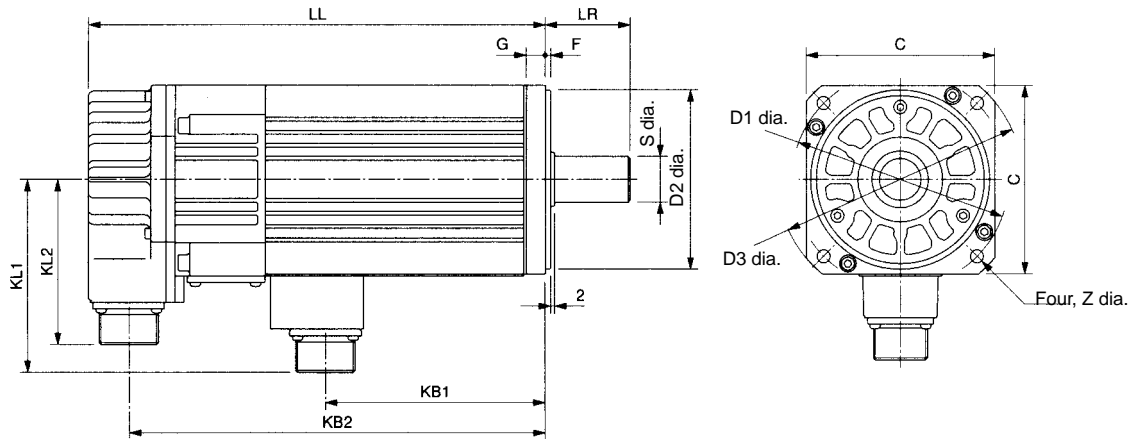

Dimensions of shaft end with key (-BS2)

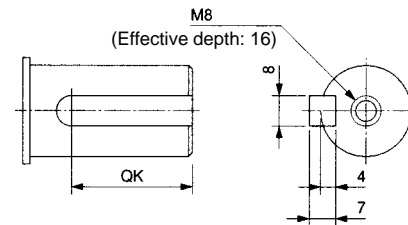

Model	Dimensions (mm)														
	LL	LR	KB1	KB2	KL1	KL2	C	D1	D2	D3	F	G	Z	S	QK
R88M-W1K030□-B□	193	45	67	171	102	88	100	115	95h7	130	3	10	7	24h6	32
R88M-W1K530□-B□	219		93	197											
R88M-W2K030□-B□	242		116	220											
R88M-W3K030□-B□	237	63	114	216	119	88	130	145	110h7	165	6	12	9	28h6	50
R88M-W4K030□-B□	274		151	253											
R88M-W5K030□-B□	314		191	293											

Note The external dimensions are the same for IP67 (waterproof) models (-BO□).

■ 3,000-r/min Flat-style Servomotors without a Brake

- 100 V AC: 100 W/200 W
 R88M-WP10030L(-S1)/-WP20030L(-S1) [Incremental]
 R88M-WP10030S(-S1)/-WP20030S(-S1) [Absolute]
- 200 V AC: 100 W/200 W/400 W/750 W/1.5 kW
 R88M-WP10030H(-S1)/-WP20030H(-S1)/-WP40030H(-S1)/-WP75030H(-S1)/
 -WP1K530H(-S1) [Incremental]
 R88M-WP10030T(-S1)/-WP20030T(-S1)/-WP40030T(-S1)/-WP75030T(-S1)/
 -WP1K530T(-S1) [Absolute]

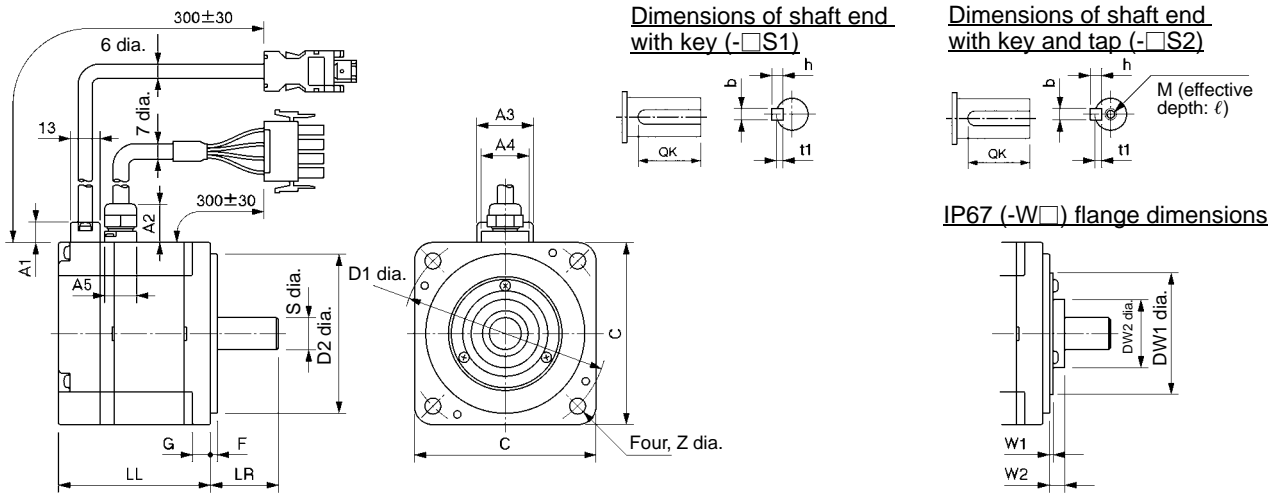

Model	Dimensions (mm)																												
	Basic servomotor dimensions								With key (shaft end dimensions)				Waterproof type (flange dimensions)				Cable lead-in section				Tap								
	LL	LR	C	D1	D2	F	G	Z	S	QK	b	h	t1	W1	W2	DW1	DW2	A1	A2	A3	A4	A5	M	ℓ					
R88M-WP10030□-□	62	25	60	70	50h7	3	6	5.5	8h6	14	3	3	1.8	1	4	39	22	9	18	25	21	14	M3	6					
R88M-WP20030□-□	67	30	80	90	70h7	3	8	7	14h6	16	5	5	3	3.5	7	49	35								28	38	19	M5	8
R88M-WP40030□-□																													
R88M-WP75030□-□	86.5	40	120	145	110h7	3.5	10	10	16h6	22	5	5	3	1.5	7	77	55	28	38	19	M6	10							
R88M-WP1K530□-□	114.5								19h6		6	6	3.5																

■ 3,000-r/min Flat-style Servomotors with a Brake

- 100 V AC: 100 W/200 W
R88M-WP10030L-B(S1)/-WP20030L-B(S1) [Incremental]
R88M-WP10030S-B(S1)/-WP20030S-B(S1) [Absolute]
- 200 V AC: 100 W/200 W/400 W/750 W/1.5 kW
R88M-WP10030H-B(S1)/-WP20030H-B(S1)/-WP40030H-B(S1)/-WP75030H-B(S1)/-WP1K530H-B(S1) [Incremental]
R88M-WP10030T-B(S1)/-WP20030T-B(S1)/-WP40030T-B(S1)/-WP75030T-B(S1)/-WP1K530T-B(S1) [Absolute]

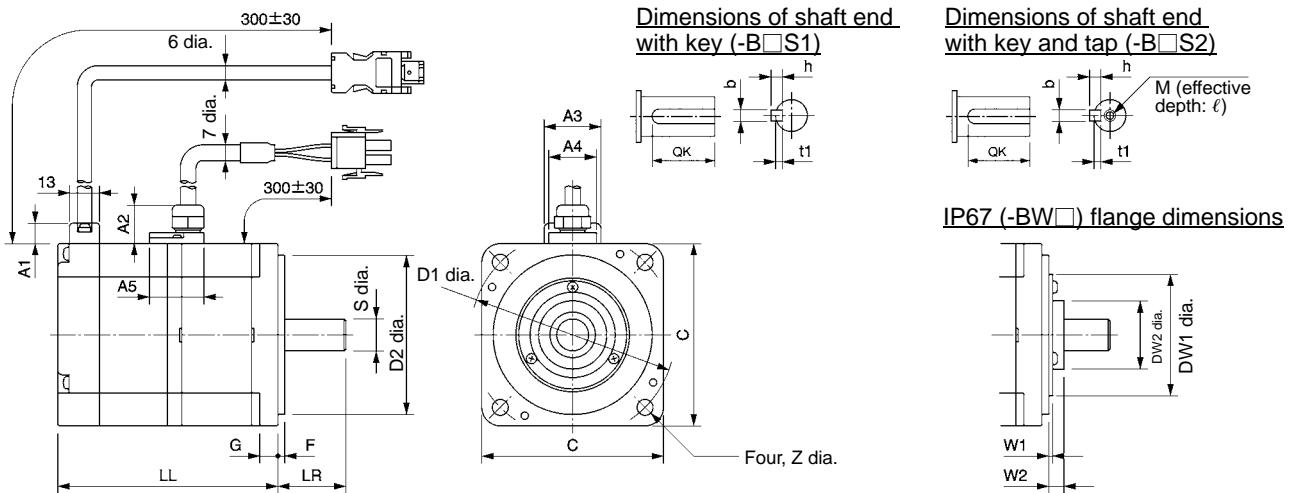

Model	Dimensions (mm)																							
	Basic servomotor dimensions								With key (shaft end dimensions)				Waterproof type (flange dimensions)				Cable lead-in section			Tap				
	LL	LR	C	D1	D2	F	G	Z	S	QK	b	h	t1	W1	W2	DW1	DW2	A1	A2	A3	A4	A5	M	ℓ
R88M-WP10030□-B□	91	25	60	70	50h7	3	6	5.5	8h6	14	3	3	1.8	1	4	39	22	9	18	25	21	23	M3	6
R88M-WP20030□-B□	98.5	30	80	90	70h7	3	8	7	14h6	16	5	5	3	3.5	7	49	35						28	38
R88M-WP40030□-B□																		118.5						
R88M-WP75030□-B□	120	40	120	145	110h7	3.5	10	10	16h6	22	5	5	3	1.5	7	77	55	9	18	25	21	23	M6	10
R88M-WP1K530□-B□									19h6		6	6	3.5											

■ 1,000-r/min Servomotors without a Brake

- 200 V AC: 300 W/600 W/900 W/1.2 kW/2.0 kW/3.0 kW
R88M-W30010H(-S2)/-W60010H(-S2)/-W90010H(-S2)/-W1K210H(-S2)/
-W2K010H(-S2)/-W3K010H(-S2) [Incremental]
R88M-W30010T(-S2)/-W60010T(-S2)/-W90010T(-S2)/-W1K210T(-S2)/
-W2K010T(-S2)/-W3K010T(-S2) [Absolute]

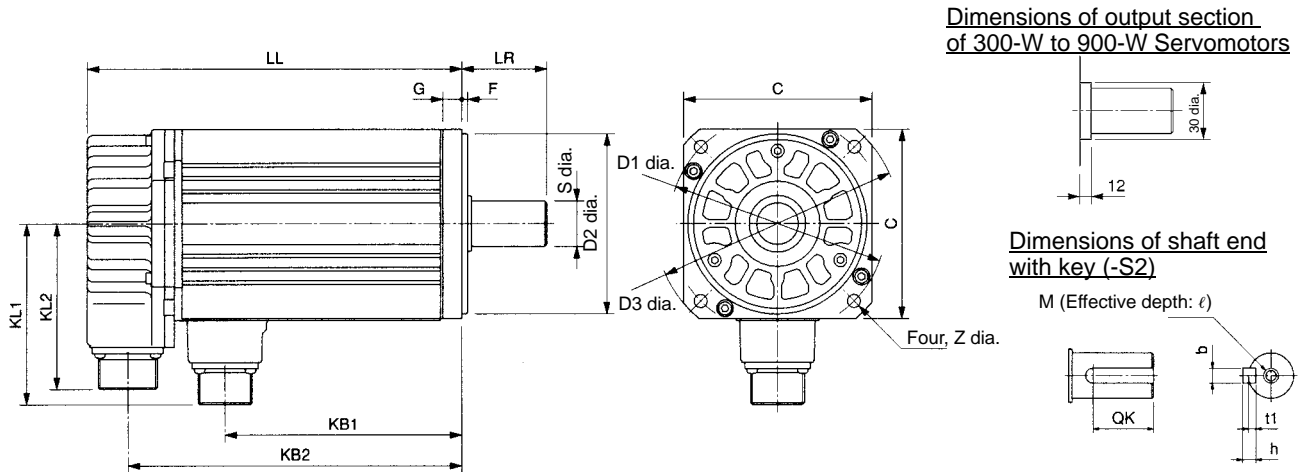

Model	Dimensions (mm)																			
	LL	LR	KB1	KB2	KL1	KL2	C	D1	D2	D3	F	G	Z	S	QK	b	h	t1	M	ℓ
R88M-W30010□-□	138	58	65	117	109	88	130	145	110h7	165	6	12	9	19h6	25	5	5	3	M5	12
R88M-W60010□-□	161		88	140																
R88M-W90010□-□	185		112	164										22h6		6	6	3.5		
R88M-W1K210□-□	166	79	89	144	140	88	180	200	114.3 ⁰ _{-0.025}	230	3.2	18	13.5	35 ^{+0.01} ₀	60	10	8	5	M12	25
R88M-W2K010□-□	192		115	170																
R88M-W3K010□-□	226		149	204																

Note The external dimensions are the same for IP67 (waterproof) models (-O□).

■ 1,000-r/min Servomotors with a Brake

- 200 V AC: 300 W/600 W/900 W/1.2 kW/2.0 kW/3.0 kW
R88M-W30010H-B(S2)/-W60010H-B(S2)/-W90010H-B(S2)/-W1K210H-B(S2)/
-W2K010H-B(S2)/-W3K010H-B(S2) [Incremental]
R88M-W30010T-B(S2)/-W60010T-B(S2)/-W90010T-B(S2)/-W1K210T-B(S2)/
-W2K010T-B(S2)/-W3K010T-B(S2) [Absolute]

Dimensions of output section of 300-W to 900-W Servomotors

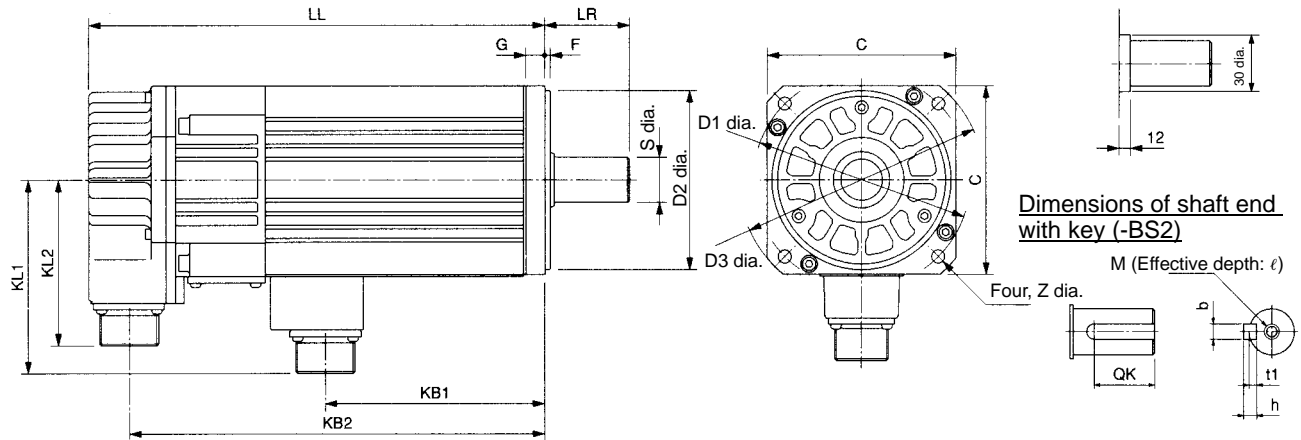

Model	Dimensions (mm)																			
	LL	LR	KB1	KB2	KL1	KL2	C	D1	D2	D3	F	G	Z	S	QK	b	h	t1	M	ℓ
R88M-W30010□-B□	176	58	56	154	120	88	130	145	110h7	165	6	12	9	19h6	25	5	5	3	M5	12
R88M-W60010□-B□	199		79	177																
R88M-W90010□-B□	223		103	201																
R88M-W1K210□-B□	217	79	79	195	146	88	180	200	114.3 ⁰ _{-0.025}	230	3.2	18	13.5	35 ^{+0.01} ₀	60	10	8	5	M12	25
R88M-W2K010□-B□	243		105	221																
R88M-W3K010□-B□	277		139	255																

Note The external dimensions are the same for IP67 (waterproof) models (-BO□).

■ 1,000-r/min Servomotors without a Brake

- 200 V AC: 4 kW/5.5 kW
R88M-W4K010H(-S2)/-W5K010H(-S2) [Incremental]
R88M-W4K010T(-S2)/-W5K010T(-S2) [Absolute]

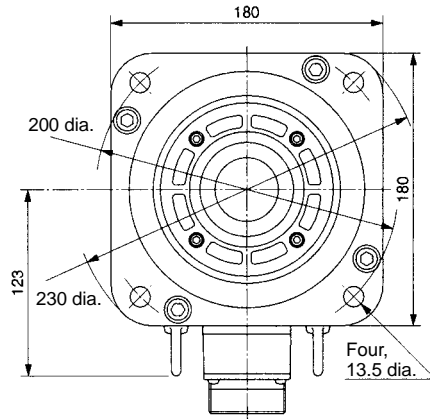
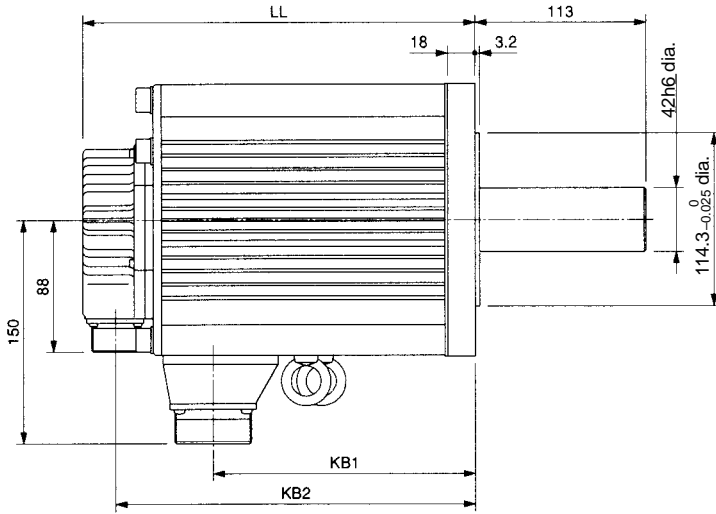

Dimensions of shaft end with key (-S2)

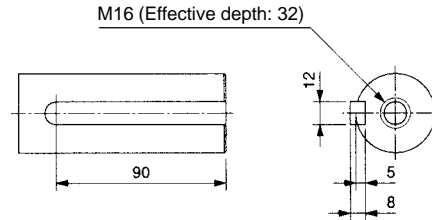

Model	Dimensions (mm)		
	LL	KB1	KB2
R88M-W4K010□-□	260	174	238
R88M-W5K010□-□	334	248	312

Note The external dimensions are the same for IP67 (waterproof) models (-O□).

■ 1,000-r/min Servomotors with a Brake

- 200 V AC: 4 kW/5.5 kW
R88M-W4K010H-B(S2)/-W5K510H-B(S2) [Incremental]
R88M-W4K010T-B(S2)/-W5K510T-B(S2) [Absolute]

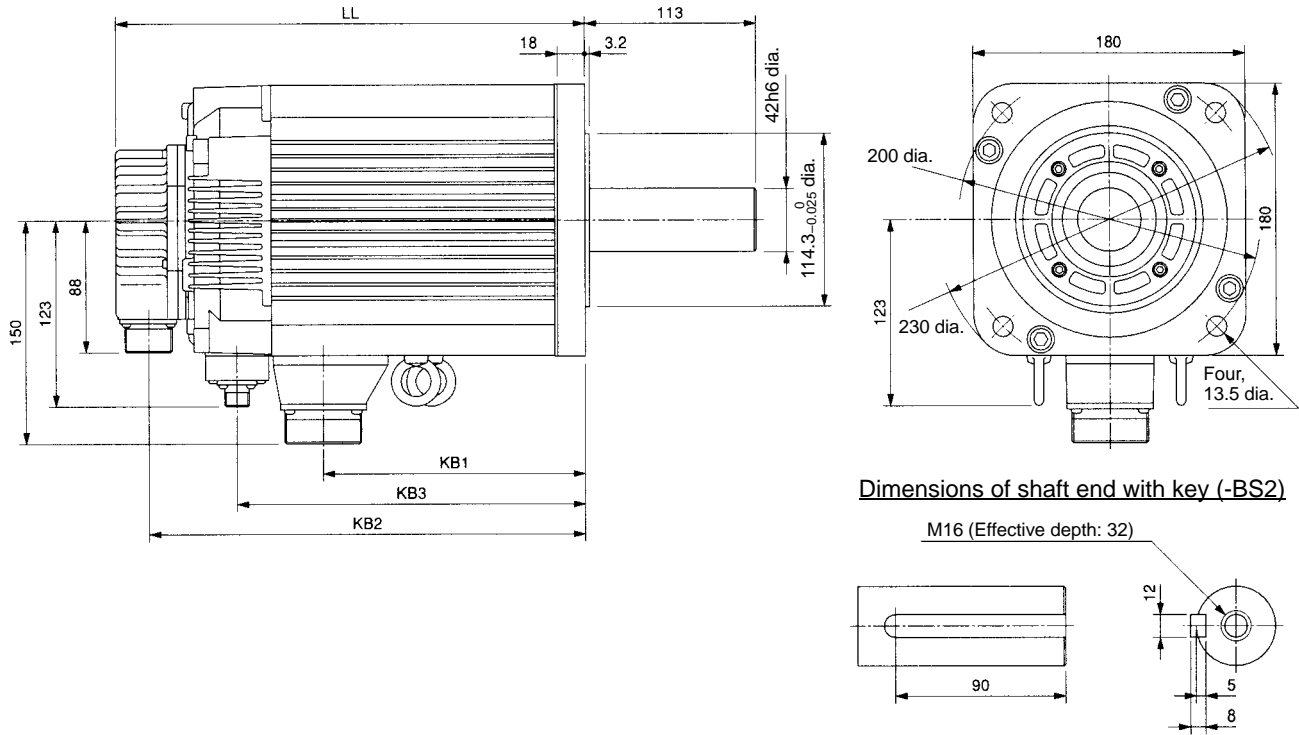

Model	Dimensions (mm)			
	LL	KB1	KB2	KB3
R88M-W4K010□-B□	311	174	289	231
R88M-W5K510□-B□	365	248	363	305

Note The external dimensions are the same for IP67 (waterproof) models (-BO□).

■ 1,500-r/min Servomotors without a Brake

- 200 V AC: 450 W/850 W/1.3 kW/1.8 kW/2.9 kW/4.4 kW
R88M-W45015T(-S2)/-W85015T(-S2)/-W1K315T(-S2)/-W1K815T(-S2)/-W2K915T(-S2)/-W4K415T(-S2) [Absolute]

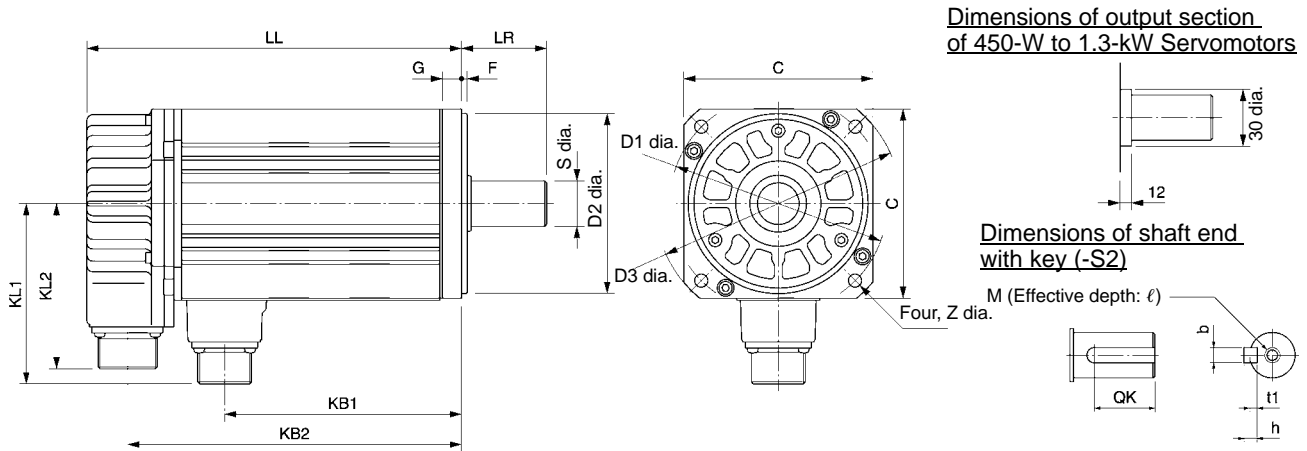

Model	Dimensions (mm)																			
	LL	LR	KB1	KB2	KL1	KL2	C	D1	D2	D3	F	G	Z	S	QK	b	h	t1	M	ℓ
R88M-W45015T-□	138	58	65	117	109	88	130	145	110h7	165	6	12	9	19h6	25	5	5	3	M5	12
R88M-W85015T-□	161		88	140										22h6		6	6	3.5		
R88M-W1K315T-□	185		112	164																
R88M-W1K815T-□	166	79	89	144	140	88	180	200	114.3 ⁰ _{-0.025}	230	3.2	18	13.5	35 ^{+0.01} ₀	60	10	8	5	M12	25
R88M-W2K915T-□	192		115	170																
R88M-W4K415T-□	226		149	204																

Note The external dimensions are the same for IP67 (waterproof) models (O□).

■ 1,500-r/min Servomotors with a Brake

- 200 V AC: 450 W/850 W/1.3 kW/1.8 kW/2.9 kW/4.4 kW
R88M-W45015T-B(S2)/-W85015T-B(S2)/-W1K315T-B(S2)/-W1K815T-B(S2)/
-W2K915T-B(S2)/-W4K415T-B(S2) [Absolute]

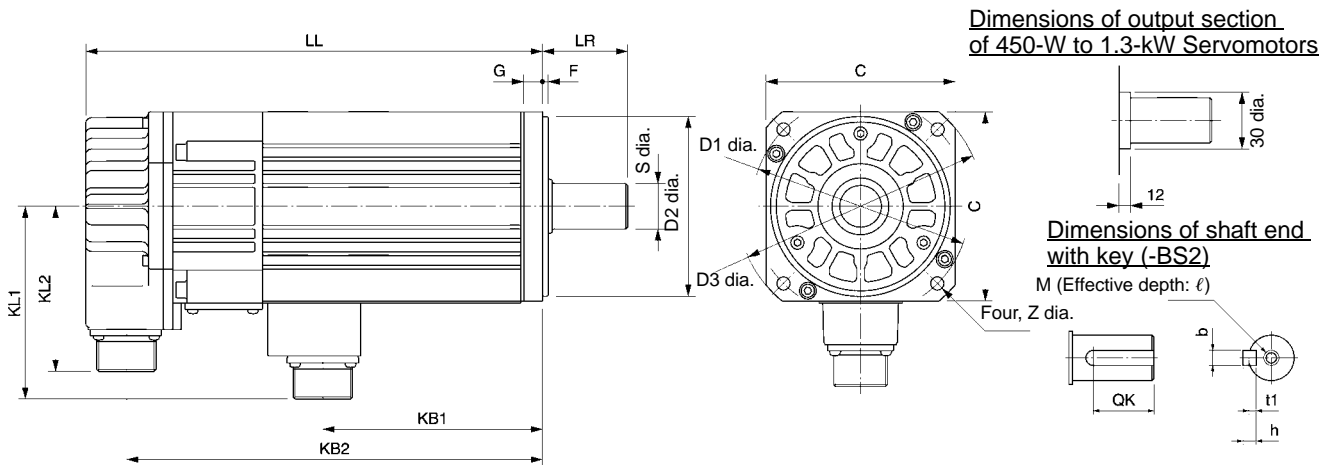

Model	Dimensions (mm)																			
	LL	LR	KB1	KB2	KL1	KL2	C	D1	D2	D3	F	G	Z	S	QK	b	h	t1	M	ℓ
R88M-W45015T-B□	176	58	56	154	120	88	130	145	110h7	165	6	12	9	19h6	25	5	5	3	M5	12
R88M-W85015T-B□	199		79	177																
R88M-W1K315T-B□	223		103	201										22h6		6	6	3.5		
R88M-W1K815T-B□	217	79	79	195	146	88	180	200	114.3 ⁰ _{-0.025}	230	3.2	18	13.5	35 ^{+0.01} ₀	60	10	8	5	M12	25
R88M-W2K915T-B□	243		105	221																
R88M-W4K415T-B□	277		139	255																

Note The external dimensions are the same for IP67 (waterproof) models (-BO□).

■ 1,500-r/min Servomotors without a Brake

- 200 V AC: 5.5 kW/7.5 kW/11 kW/15 kW
R88M-W5K515T(-S2)/-W7K515T(-S2)/-W11K015T(-S2)/-W15K015T(-S2) [Absolute]

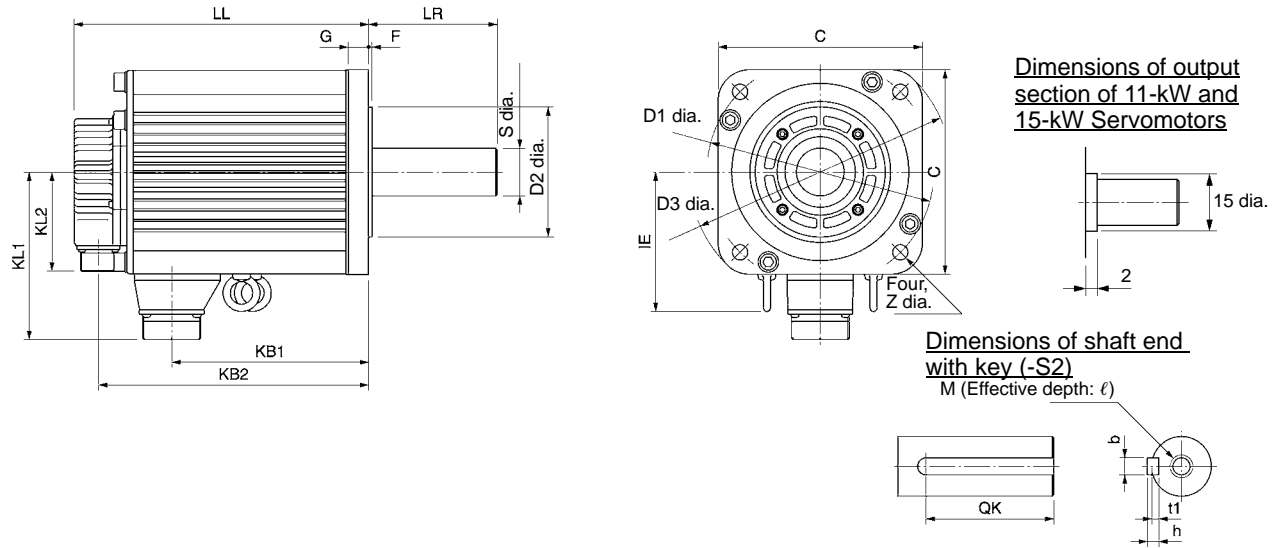

Model	Dimensions (mm)																				
	LL	LR	KB1	KB2	KL1	KL2	IE	C	D1	D2	D3	F	G	Z	S	QK	b	h	t1	M	ℓ
R88M-W5K515T-□	260	113	174	238	150	150	123	180	200	114.3 ⁰ _{-0.025}	230	3.2	18	13.5	42h6	90	12	8	5	M16	32
R88M-W7K515T-□	334		248	312																	
R88M-W11K015T-□	338	116	251	317	168	168	142	220	235	200h7	270	4	18	13.5	42h6	90	12	8	5	M16	32
R88M-W15K015T-□	457		343	435			150						20		55 ^{+0.030} _{+0.011}		16	10	6	M20	40

Note The external dimensions are the same for IP67 (waterproof) models (O□).

■ 1,500-r/min Servomotors with a Brake

- 200 V AC: 5.5 kW/7.5 kW/11 kW/15 kW
R88M-W5K515T-B(S2)/-W7K515T-B(S2)/-W11K015T-B(S2)/-W15K015T-B(S2)
[Absolute]

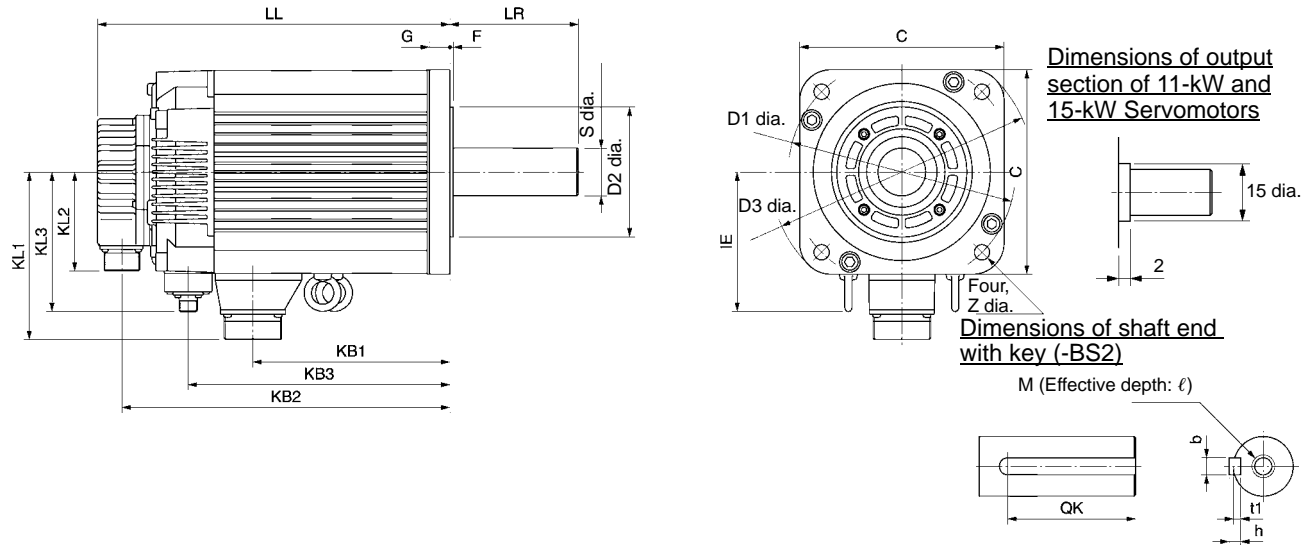

Model	Dimensions (mm)																						
	LL	LR	KB1	KB2	KB3	KL1	KL2	KL3	IE	C	D1	D2	D3	F	G	Z	S	QK	b	h	t1	M	ℓ
R88M-W5K515T-B□	311	113	174	289	231	150	88	123	123	180	200	114.3 ⁰ _{-0.025}	230	3.2	18	13.5	42h6	90	12	8	5	M16	32
R88M-W7K515T-B□	385		248	363	305							114.3 ⁰ _{-0.025}											
R88M-W11K015T-B□	383	116	258	362	315	168	88	142	142	220	235	200h7	270	4	18	13.5	42h6	90	12	8	5	M16	32
R88M-W15K015T-B□	519		343	497	415				150						20		55 ^{+0.030} _{+0.011}		16	10	6	M20	40

Note The external dimensions are the same for IP67 (waterproof) models (-BO□).

2-3-4 AC Servomotors with Gears

■ AC Servomotors with Standard Gears

● 3,000-r/min Servomotors (30 to 750 W) with Standard Gears

Model			Dia-gram No.	Dimensions (mm)											
				LL		LM	LR	C1	C2	D1	D2	D3	D4	D5	D6
				WOB*	WB*										
30 W	1/5	R88M-W03030□-□G05BJ	1, 1-1	69.5	101	28	55	60	40	80	70	56	55.5	40	---
	1/9	R88M-W03030□-□G09BJ		69.5	101	28	55	60	40	80	70	56	55.5	40	---
	1/21	R88M-W03030□-□G21BJ		69.5	101	43	55	60	40	60	70	56	55.5	40	---
	1/33	R88M-W03030□-□G33BJ		69.5	101	43	55	60	40	80	70	56	55.5	40	---
50 W	1/5	R88M-W05030□-□G05BJ	1, 1-1	77	108.5	28	55	60	40	80	70	56	55.5	40	---
	1/9	R88M-W05030□-□G09BJ		77	108.5	29	60	70	40	95	80	65	64.5	50	---
	1/21	R88M-W05030□-□G21BJ	1, 1-2	77	108.5	46	60	70	40	(92)	80	65	64.5	40	8
	1/33	R88M-W05030□-□G33BJ		77	108.5	46	60	70	40	(92)	80	65	64.5	40	8
100 W	1/5	R88M-W10030□-□G05BJ	1, 1-2	94.5	135	29	60	70	40	(92)	80	65	64.5	40	8
	1/11	R88M-W10030□-□G11BJ		94.5	135	46	60	70	40	(92)	80	65	64.5	40	8
	1/21	R88M-W10030□-□G21BJ		94.5	135	55	74	90	40	(120)	105	85	84	59	9
	1/33	R88M-W10030□-□G33BJ		94.5	135	55	74	90	40	(120)	105	85	84	59	9
200 W	1/5	R88M-W20030□-□G05BJ	2	96.5	136	38	74	90	60	(120)	105	85	84	59	9
	1/11	R88M-W20030□-□G11BJ		96.5	136	55	74	90	60	(120)	105	85	84	59	9
	1/21	R88M-W20030□-□G21BJ		96.5	136	63	84	105	60	(139)	120	100	96	59	12
	1/33	R88M-W20030□-□G33BJ		96.5	136	63	84	105	60	(139)	120	100	96	59	12
400 W	1/5	R88M-W40030□-□G05BJ	2	124.5	164	38	74	90	60	(120)	105	85	84	59	9
	1/11	R88M-W40030□-□G11BJ		124.5	164	63	84	105	60	(139)	120	100	96	59	12
	1/21	R88M-W40030□-□G21BJ		124.5	164	71	105	120	60	(158)	135	115	112	59	14
	1/33	R88M-W40030□-□G33BJ		124.5	164	71	105	120	60	(158)	135	115	114	84	14
750 W	1/5	R88M-W75030□-□G05BJ	2	145	189.5	42	84	105	80	(139)	120	100	96	59	12
	1/11	R88M-W75030□-□G11BJ		145	189.5	71	105	120	80	(158)	135	115	112	59	14
	1/21	R88M-W75030□-□G21BJ		145	189.5	78	142	145	80	(192)	165	140	134	84	16
	1/33	R88M-W75030□-□G33BJ		145	189.5	78	142	145	80	(192)	165	140	134	84	16

Note 1. WOB and WB mean "without brake" and "with brake" respectively.

Note 2. The values in parentheses are reference values.

Diagram 1

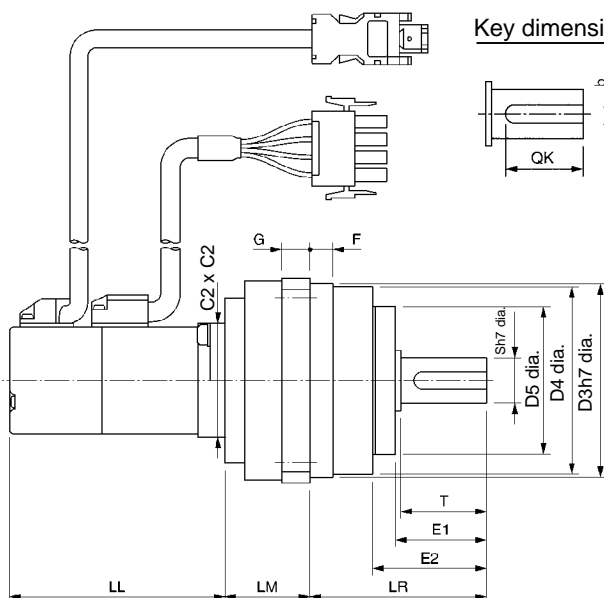

Key dimensions

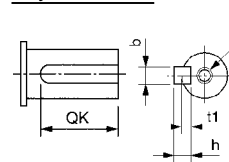

Diagram 1-1

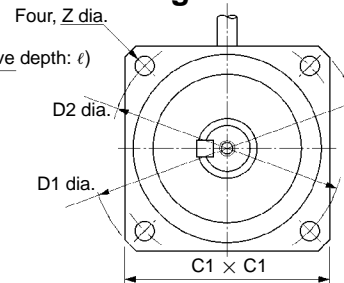
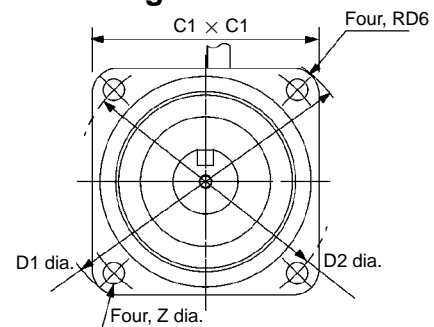
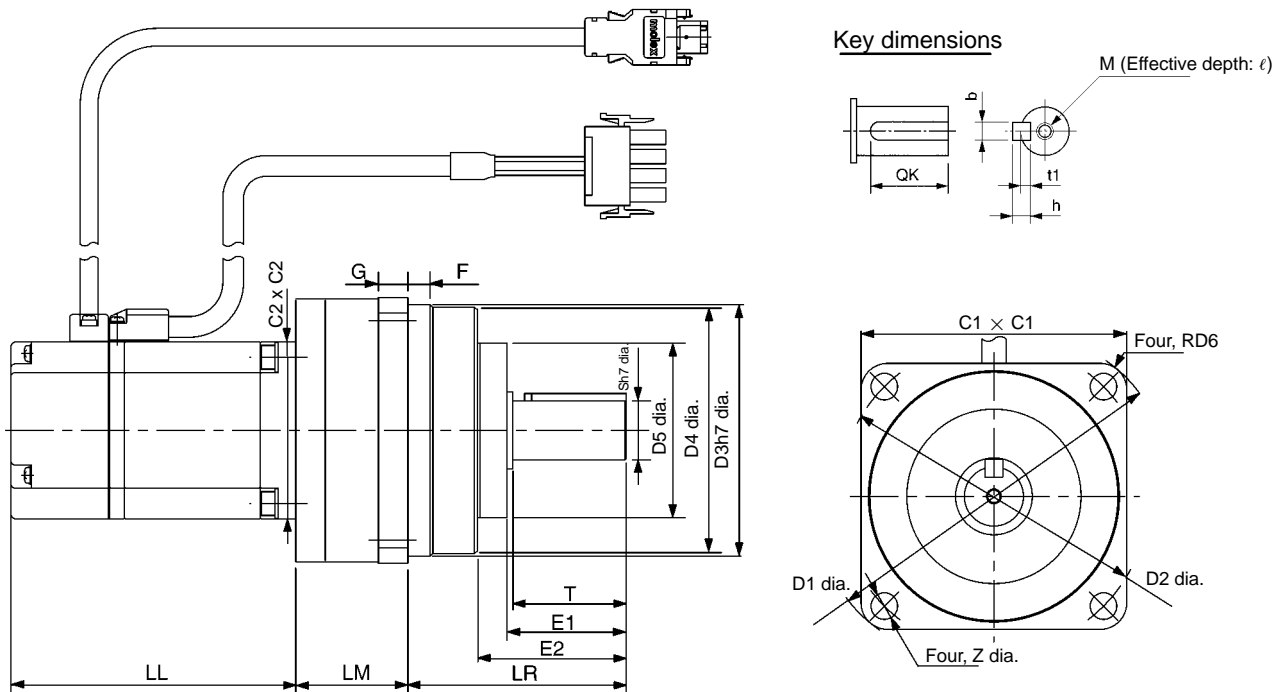

Diagram 1-2



Dimensions (mm)												Model			
E1	E2	F	G	S	T	Z	Key dimensions								
							QK	b	h	t1	M				ℓ
27	35	6	8	14	25	5.5	20	5	5	3	M4	8	30 W	1/5	R88M-W03030□-□G05BJ
27	35	6	8	14	25	5.5	20	5	5	3	M4	8		1/9	R88M-W03030□-□G09BJ
27	35	6	8	14	25	5.5	20	5	5	3	M4	8		1/21	R88M-W03030□-□G21BJ
27	35	6	8	14	25	5.5	20	5	5	3	M4	8		1/33	R88M-W03030□-□G33BJ
27	35	6	8	14	25	5.5	20	5	5	3	M4	8	50 W	1/5	R88M-W05030□-□G05BJ
30	38	8	9	16	28	6.6	25	5	5	3	M4	8		1/9	R88M-W05030□-□G09BJ
30	39	8	9	16	28	6.6	25	5	5	3	M4	8		1/21	R88M-W05030□-□G21BJ
30	39	8	9	16	28	6.6	25	5	5	3	M4	8		1/33	R88M-W05030□-□G33BJ
30	39	8	9	16	28	6.6	25	5	5	3	M4	8	100 W	1/5	R88M-W10030□-□G05BJ
30	39	8	9	16	28	6.6	25	5	5	3	M4	8		1/11	R88M-W10030□-□G11BJ
38	48	7.5	10	20	36	9	32	6	6	3.5	M5	10		1/21	R88M-W10030□-□G21BJ
38	48	7.5	10	20	36	9	32	6	6	3.5	M5	10		1/33	R88M-W10030□-□G33BJ
38	48	7.5	10	20	36	9	32	6	6	3.5	M5	10	200 W	1/5	R88M-W20030□-□G05BJ
38	48	7.5	10	20	36	9	32	6	6	3.5	M5	10		1/11	R88M-W20030□-□G11BJ
44	55	12	12	25	42	9	36	8	7	4	M6	12		1/21	R88M-W20030□-□G21BJ
44	55	12	12	25	42	9	36	8	7	4	M6	12		1/33	R88M-W20030□-□G33BJ
38	48	7.5	10	20	36	9	32	6	6	3.5	M5	10	400 W	1/5	R88M-W40030□-□G05BJ
44	55	12	12	25	42	9	36	8	7	4	M6	12		1/11	R88M-W40030□-□G11BJ
60	72	14	13	32	58	11	50	10	8	5	M8	16		1/21	R88M-W40030□-□G21BJ
60	72	12.5	13	32	58	11	50	10	8	5	M8	16		1/33	R88M-W40030□-□G33BJ
44	55	12	12	25	42	9	36	8	7	4	M6	12	750 W	1/5	R88M-W75030□-□G05BJ
60	72	14	13	32	58	11	50	10	8	5	M8	16		1/11	R88M-W75030□-□G11BJ
85	102	10	15	40	82	14	70	12	8	5	M10	20		1/21	R88M-W75030□-□G21BJ
85	102	10	15	40	82	14	70	12	8	5	M10	20		1/33	R88M-W75030□-□G33BJ

Diagram 2



• 3,000-r/min Servomotors (1 to 5 kW) with Standard Gears

Model			Dia-gram No.	Dimensions (mm)										
				LL		LM	LR	C1	C2	D1	D2	D3	D4	D5
				WOB*	WB*									
1 kW	1/5	R88M-W1K030□-□G05BJ	1	149	193	154	100	140	100	185	160	130	94	91
	1/9	R88M-W1K030□-□G09BJ		149	193	166	100	140	100	185	160	130	94	91
	1/20	R88M-W1K030□-□G20BJ	2	149	193	207	140	—	100	245	220	190	135	130
	1/29	R88M-W1K030□-□G29BJ		149	193	207	140	—	100	245	220	190	135	130
	1/45	R88M-W1K030□-□G45BJ		149	193	217	140	—	100	245	220	190	135	130
1.5 kW	1/5	R88M-W1K530□-□G05BJ	1	175	219	154	100	140	100	185	160	130	94	91
	1/9	R88M-W1K530□-□G09BJ	2	175	219	203	140	—	100	245	220	190	135	130
	1/20	R88M-W1K530□-□G20BJ		175	219	207	140	—	100	245	220	190	135	130
	1/29	R88M-W1K530□-□G29BJ	175	219	207	140	—	100	245	220	190	135	130	
	1/45	R88M-W1K530□-□G45BJ	175	219	238	160	—	100	310	280	240	186	182	
2 kW	1/5	R88M-W2K030□-□G05BJ	1	198	242	154	100	140	100	185	160	130	94	91
	1/9	R88M-W2K030□-□G09BJ	2	198	242	203	140	—	100	245	220	190	135	130
	1/20	R88M-W2K030□-□G20BJ		198	242	207	140	—	100	245	220	190	135	130
	1/29	R88M-W2K030□-□G29BJ	198	242	228	160	—	100	310	280	240	186	182	
	1/45	R88M-W2K030□-□G45BJ	198	242	238	160	—	100	310	280	240	186	182	
3 kW	1/5	R88M-W3K030□-□G05BJ	2	199	237	201	140	—	130	245	220	190	135	130
	1/9	R88M-W3K030□-□G09BJ		199	237	228	140	—	130	245	220	190	135	130
	1/20	R88M-W3K030□-□G20BJ	199	237	253	160	—	130	310	280	240	186	182	
	1/29	R88M-W3K030□-□G29BJ	199	237	253	160	—	130	310	280	240	186	182	
	1/45	R88M-W3K030□-□G45BJ	199	237	263	160	—	130	310	280	240	186	182	
4 kW	1/5	R88M-W4K030□-□G05BJ	2	236	274	201	140	—	130	245	220	190	135	130
	1/9	R88M-W4K030□-□G09BJ		236	274	253	160	—	130	310	280	240	186	182
	1/20	R88M-W4K030□-□G20BJ		236	274	253	160	—	130	310	280	240	186	182
	1/29	R88M-W4K030□-□G29BJ		236	274	253	160	—	130	310	280	240	186	182
5 kW	1/5	R88M-W5K030□-□G05BJ	2	276	314	221	160	—	130	310	280	240	186	182
	1/9	R88M-W5K030□-□G09BJ		276	314	253	160	—	130	310	280	240	186	182
	1/20	R88M-W5K030□-□G20BJ		276	314	253	160	—	130	310	280	240	186	182

Note WOB and WB mean “without brake” and “with brake” respectively.

Diagram 1

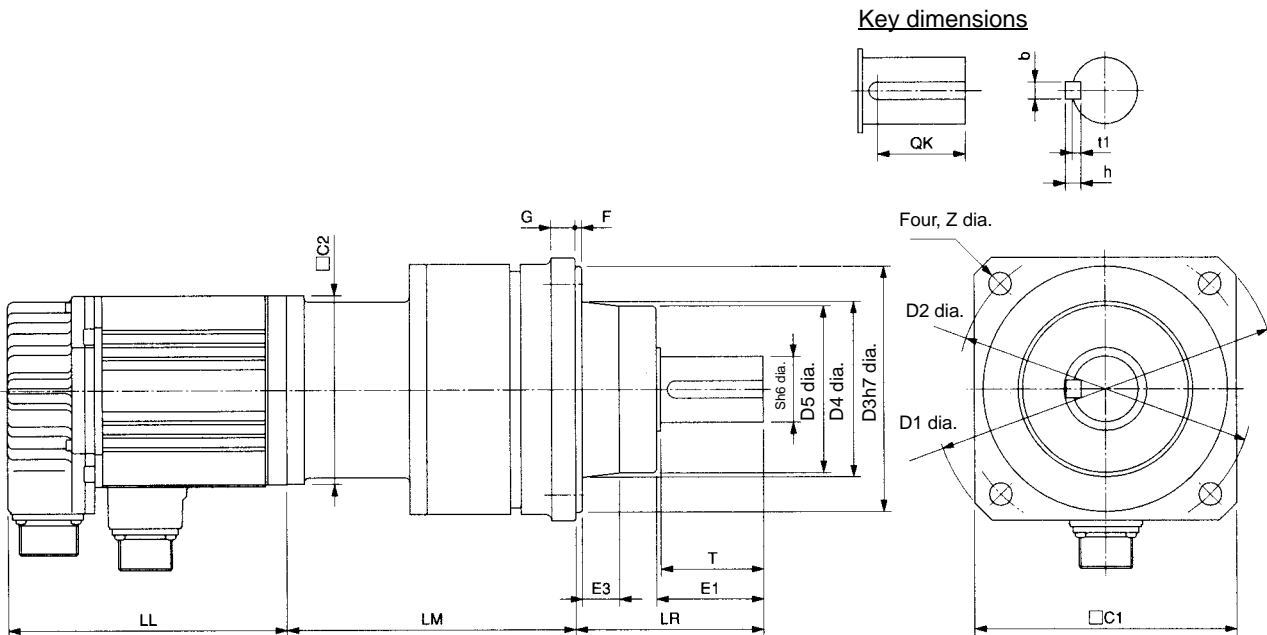

Dimensions (mm)												Model		
E1	E3	F	G	S	T	Z	IE	Key dimensions						
								QK	b	h	t1			
57	20	3	12	35	55	12	—	47	10	8	5	1 kW	1/5	R88M-W1K030□-□G05BJ
57	20	3	12	35	55	12	—	47	10	8	5		1/9	R88M-W1K030□-□G09BJ
77	33	5	15	50	75	12	137	65	14	9	5.5		1/20	R88M-W1K030□-□G20BJ
77	33	5	15	50	75	12	137	65	14	9	5.5		1/29	R88M-W1K030□-□G29BJ
77	33	5	15	50	75	12	137	65	14	9	5.5		1/45	R88M-W1K030□-□G45BJ
57	20	3	12	35	55	12	—	47	10	8	5	1.5 kW	1/5	R88M-W1K530□-□G05BJ
77	33	5	15	50	75	12	137	65	14	9	5.5		1/9	R88M-W1K530□-□G09BJ
77	33	5	15	50	75	12	137	65	14	9	5.5		1/20	R88M-W1K530□-□G20BJ
77	33	5	15	50	75	12	137	65	14	9	5.5		1/29	R88M-W1K530□-□G29BJ
92	38	5	18	60	90	14	171	78	18	11	7		1/45	R88M-W1K530□-□G45BJ
57	20	3	12	35	55	12	—	47	10	8	5	2 kW	1/5	R88M-W2K030□-□G05BJ
77	33	5	15	50	75	12	137	65	14	9	5.5		1/9	R88M-W2K030□-□G09BJ
77	33	5	15	50	75	12	137	65	14	9	5.5		1/20	R88M-W2K030□-□G20BJ
92	38	5	18	60	90	14	171	78	18	11	7		1/29	R88M-W2K030□-□G29BJ
92	38	5	18	60	90	14	171	78	18	11	7		1/45	R88M-W2K030□-□G45BJ
77	33	5	15	50	75	12	137	65	14	9	5.5	3 kW	1/5	R88M-W3K030□-□G05BJ
77	33	5	15	50	75	12	137	65	14	9	5.5		1/9	R88M-W3K030□-□G09BJ
92	38	5	18	60	90	14	171	78	18	11	7		1/20	R88M-W3K030□-□G20BJ
92	38	5	18	60	90	14	171	78	18	11	7		1/29	R88M-W3K030□-□G29BJ
92	38	5	18	60	90	14	171	78	18	11	7		1/45	R88M-W3K030□-□G45BJ
77	33	5	15	50	75	12	137	65	14	9	5.5	4 kW	1/5	R88M-W4K030□-□G05BJ
92	38	5	18	60	90	14	171	78	18	11	7		1/9	R88M-W4K030□-□G09BJ
92	38	5	18	60	90	14	171	78	18	11	7		1/20	R88M-W4K030□-□G20BJ
92	38	5	18	60	90	14	171	78	18	11	7		1/29	R88M-W4K030□-□G29BJ
92	38	5	18	60	90	14	171	78	18	11	7		1/45	R88M-W4K030□-□G45BJ
92	38	5	18	60	90	14	171	78	18	11	7	5 kW	1/5	R88M-W5K030□-□G05BJ
92	38	5	18	60	90	14	171	78	18	11	7		1/9	R88M-W5K030□-□G09BJ
92	38	5	18	60	90	14	171	78	18	11	7		1/20	R88M-W5K030□-□G20BJ

Diagram 2

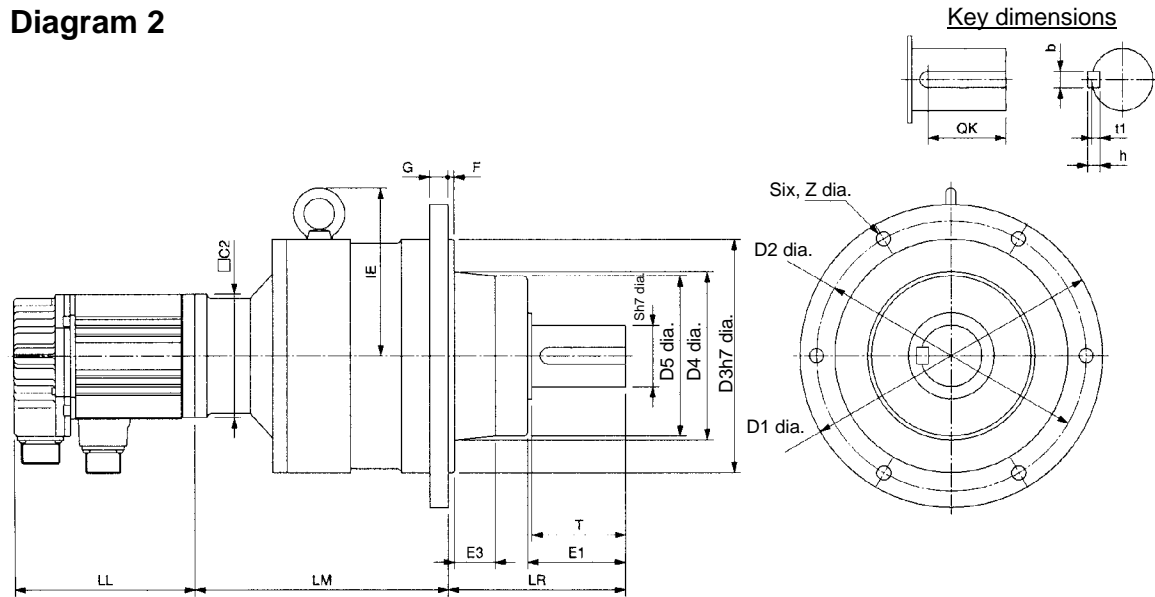

• 3,000-r/min Flat-style Servomotors (100 W to 1.5 kW) with Standard Gears

Model			Dia-gram No.	Dimensions (mm)											
				LL		LM	LR	C1	C2	D1	D2	D3	D4	D5	D6
				WOB*	WB*										
100 W	1/5	R88M-WP10030□-□G05BJ	1	62	91	46	60	70	60	(92)	80	65	64.5	40	8
	1/11	R88M-WP10030□-□G11BJ		62	91	46	60	70	60	(92)	80	65	64.5	40	8
	1/21	R88M-WP10030□-□G21BJ		62	91	55	74	90	60	(120)	105	85	84	59	9
	1/33	R88M-WP10030□-□G33BJ		62	91	55	74	90	60	(120)	105	85	84	59	9
200 W	1/5	R88M-WP20030□-□G05BJ	1	67	98.5	56	74	90	80	(120)	105	85	84	59	9
	1/11	R88M-WP20030□-□G11BJ		67	98.5	56	74	90	80	(120)	105	85	84	59	9
	1/21	R88M-WP20030□-□G21BJ		67	98.5	64	84	105	80	(139)	120	100	96	59	12
	1/33	R88M-WP20030□-□G33BJ		67	98.5	64	84	105	80	(139)	120	100	96	59	12
400 W	1/5	R88M-WP40030□-□G05BJ	1	87	118.5	56	74	90	80	(120)	105	85	84	59	9
	1/11	R88M-WP40030□-□G11BJ		87	118.5	64	84	105	80	(139)	120	100	96	59	12
	1/21	R88M-WP40030□-□G21BJ		87	118.5	71	105	120	80	(158)	135	115	112	59	14
	1/33	R88M-WP40030□-□G33BJ		87	118.5	72	105	120	80	(158)	135	115	114	84	14
750 W	1/5	R88M-WP75030□-□G05BJ	1	86.5	120	64	84	105	120	(139)	120	100	96	59	12
	1/11	R88M-WP75030□-□G11BJ		86.5	120	72	105	120	120	(158)	135	115	112	59	14
	1/21	R88M-WP75030□-□G21BJ		96.5	120	88	142	145	120	(192)	165	140	134	84	16
	1/33	R88M-WP75030□-□G33BJ		96.5	120	88	142	145	120	(192)	165	140	134	84	16
1.5 kW	1/5	R88M-WP1K530□-□G05BJ	1	114.5	148	72	105	120	120	(158)	135	115	114	84	14
	1/11	R88M-WP1K530□-□G11BJ		114.5	148	88	142	145	120	(192)	165	140	134	84	16
	1/21	R88M-WP1K530□-□G21BJ	2	114.5	148	94	156	170	120	215	190	165	163	135	---
	1/33	R88M-WP1K530□-□G33BJ		114.5	148	94	156	170	120	215	190	165	163	135	---

Note 1. WOB and WB mean “without brake” and “with brake” respectively.

Note 2. The values in parentheses are reference values.

Diagram 1

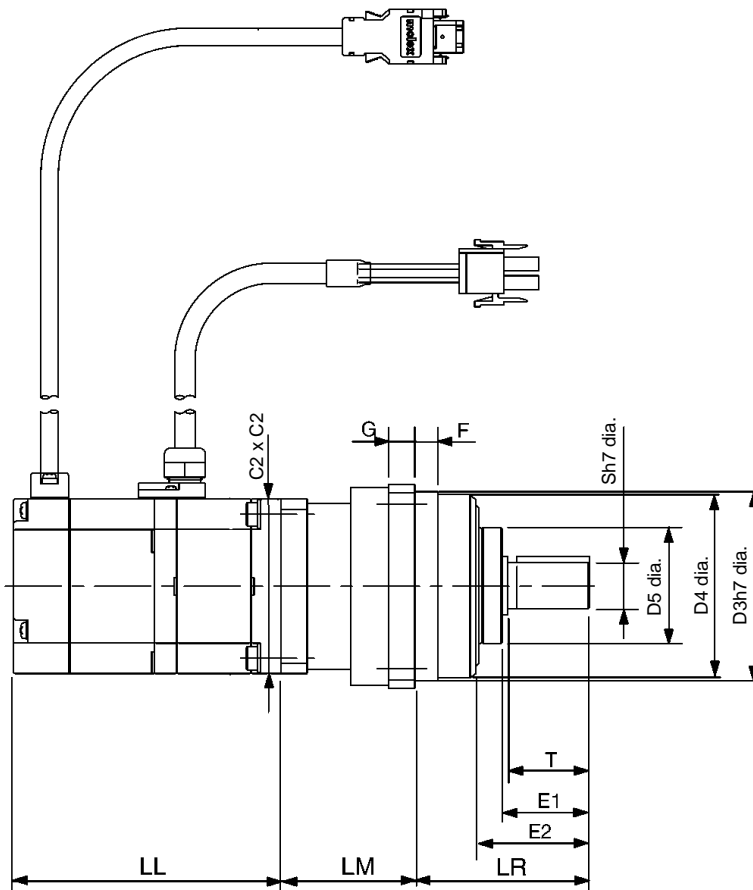

Key dimensions

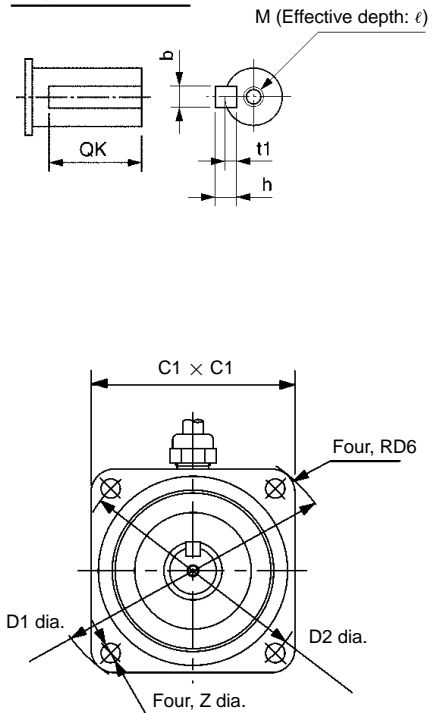

Dimensions (mm)													Model		
E1	E2	F	G	S	T	Z	Key dimensions								
							QK	b	h	t1	M	ℓ			
30	39	8	9	16	28	6.6	25	5	5	3	M4	8	100 W	1/5	R88M-WP10030□-□G05BJ
30	39	8	9	16	28	6.6	25	5	5	3	M4	8		1/11	R88M-WP10030□-□G11BJ
38	48	7.5	10	20	36	9	32	6	6	3.5	M5	10		1/21	R88M-WP10030□-□G21BJ
38	48	7.5	10	20	36	9	32	6	6	3.5	M5	10		1/33	R88M-WP10030□-□G33BJ
38	48	7.5	10	20	36	9	32	6	6	3.5	M5	10	200 W	1/5	R88M-WP20030□-□G05BJ
38	48	7.5	10	20	36	9	32	6	6	3.5	M5	10		1/11	R88M-WP20030□-□G11BJ
44	55	12	12	25	42	9	36	8	7	4	M6	12		1/21	R88M-WP20030□-□G21BJ
44	55	12	12	25	42	9	36	8	7	4	M6	12		1/33	R88M-WP20030□-□G33BJ
38	48	7.5	10	20	36	9	32	6	6	3.5	M5	10	400 W	1/5	R88M-WP40030□-□G05BJ
44	55	12	12	25	42	9	36	8	7	4	M6	12		1/11	R88M-WP40030□-□G11BJ
60	72	14	13	32	58	11	50	10	8	5	M8	16		1/21	R88M-WP40030□-□G21BJ
60	72	12.5	13	32	58	11	50	10	8	5	M8	16		1/33	R88M-WP40030□-□G33BJ
44	55	12	12	25	42	9	36	8	7	4	M6	12	750 W	1/5	R88M-WP75030□-□G05BJ
60	72	14	13	32	58	11	50	10	8	5	M8	16		1/11	R88M-WP75030□-□G11BJ
85	102	10	15	40	82	14	70	12	8	5	M10	20		1/21	R88M-WP75030□-□G21BJ
85	102	10	15	40	82	14	70	12	8	5	M10	20		1/33	R88M-WP75030□-□G33BJ
60	72	12.5	13	32	58	11	50	10	8	5	M8	16	1.5 kW	1/5	R88M-WP1K530□-□G05BJ
85	102	10	15	40	82	14	70	12	8	5	M10	20		1/11	R88M-WP1K530□-□G11BJ
86	105	16	16	45	82	14	70	14	9	5.5	M10	20		1/21	R88M-WP1K530□-□G21BJ
86	105	16	16	45	82	14	70	14	9	5.5	M10	20		1/33	R88M-WP1K530□-□G33BJ

Diagram 2

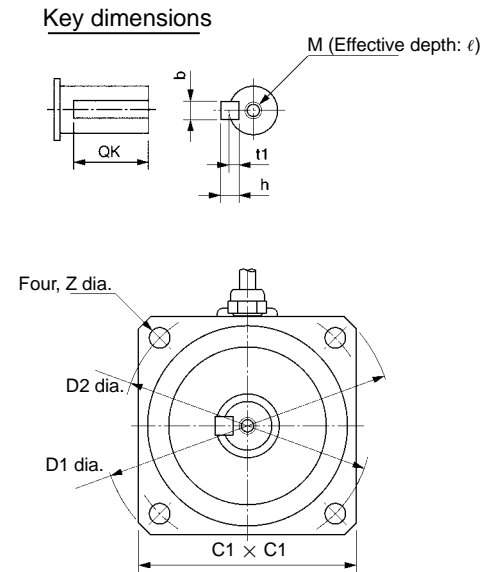
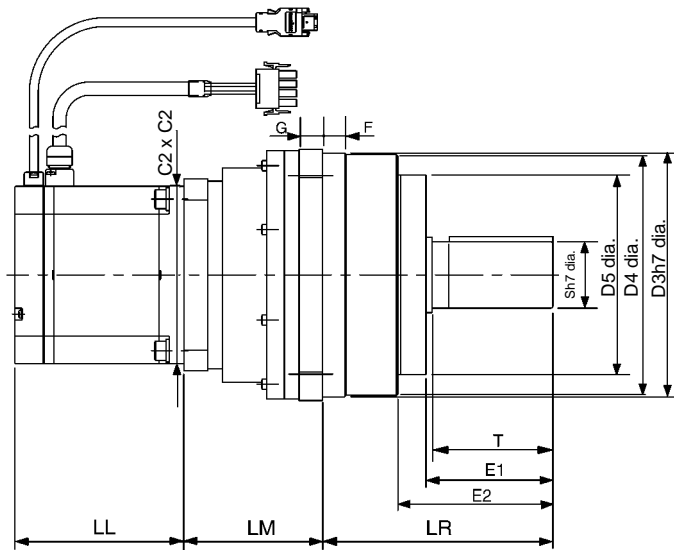

• 1,000-r/min Servomotors (300 to 3 kW) with Standard Gears

Model			Diagram No.	Dimensions (mm)											
				LL		LM	LR	C1	C2	D1	D2	D3	D4	D5	
				WOB*	WB*										
300 W	1/5	R88M-W30010□-□G05BJ	1	138	176	156	100	140	130	185	160	130	94	91	
	1/9	R88M-W30010□-□G09BJ		138	176	168	100	140	130	185	160	130	94	91	
	1/20	R88M-W30010□-□G20BJ		138	176	187	100	140	130	185	160	130	94	91	
	1/29	R88M-W30010□-□G29BJ	2	138	176	213	140	—	130	245	220	190	135	130	
	1/45	R88M-W30010□-□G45BJ		138	176	223	140	—	130	245	220	190	135	130	
600 W	1/5	R88M-W60010□-□G05BJ	1	161	199	156	100	140	130	185	160	130	94	91	
	1/9	R88M-W60010□-□G09BJ		161	199	168	100	140	130	185	160	130	94	91	
	1/20	R88M-W60010□-□G20BJ		2	161	199	213	140	—	130	245	220	190	135	130
	1/29	R88M-W60010□-□G29BJ	161		199	213	140	—	130	245	220	190	135	130	
	1/45	R88M-W60010□-□G45BJ	161	199	244	160	—	130	310	280	240	186	182		
900 W	1/5	R88M-W90010□-□G05BJ	1	185	223	156	100	140	130	185	160	130	94	91	
	1/9	R88M-W90010□-□G09BJ		2	185	223	209	140	—	130	245	220	190	135	130
	1/20	R88M-W90010□-□G20BJ			185	223	213	140	—	130	245	220	190	135	130
	1/29	R88M-W90010□-□G29BJ	185	223	234	160	—	130	310	280	240	186	182		
	1/45	R88M-W90010□-□G45BJ	185	223	244	160	—	130	310	280	240	186	182		
1.2 kW	1/5	R88M-W1K210□-□G05BJ	2	166	217	203	140	—	180	245	220	190	135	130	
	1/9	R88M-W1K210□-□G09BJ		166	217	230	140	—	180	245	220	190	135	130	
	1/20	R88M-W1K210□-□G20BJ		166	217	255	160	—	180	310	280	240	186	182	
	1/29	R88M-W1K210□-□G29BJ	166	217	255	160	—	180	310	280	240	186	182		
	1/45	R88M-W1K210□-□G45BJ	166	217	265	160	—	180	310	280	240	186	182		
2 kW	1/5	R88M-W2K010□-□G05BJ	2	192	243	203	140	—	180	245	220	190	135	130	
	1/9	R88M-W2K010□-□G09BJ		192	243	230	140	—	180	245	220	190	135	130	
	1/20	R88M-W2K010□-□G20BJ		192	243	255	160	—	180	310	280	240	186	182	
3 kW	1/5	R88M-W3K010□-□G05BJ	2	226	277	223	160	—	180	310	280	240	186	182	
	1/9	R88M-W3K010□-□G11BJ		226	277	255	160	—	180	310	280	240	186	182	

Note WOB and WB mean “without brake” and “with brake” respectively.

Diagram 1

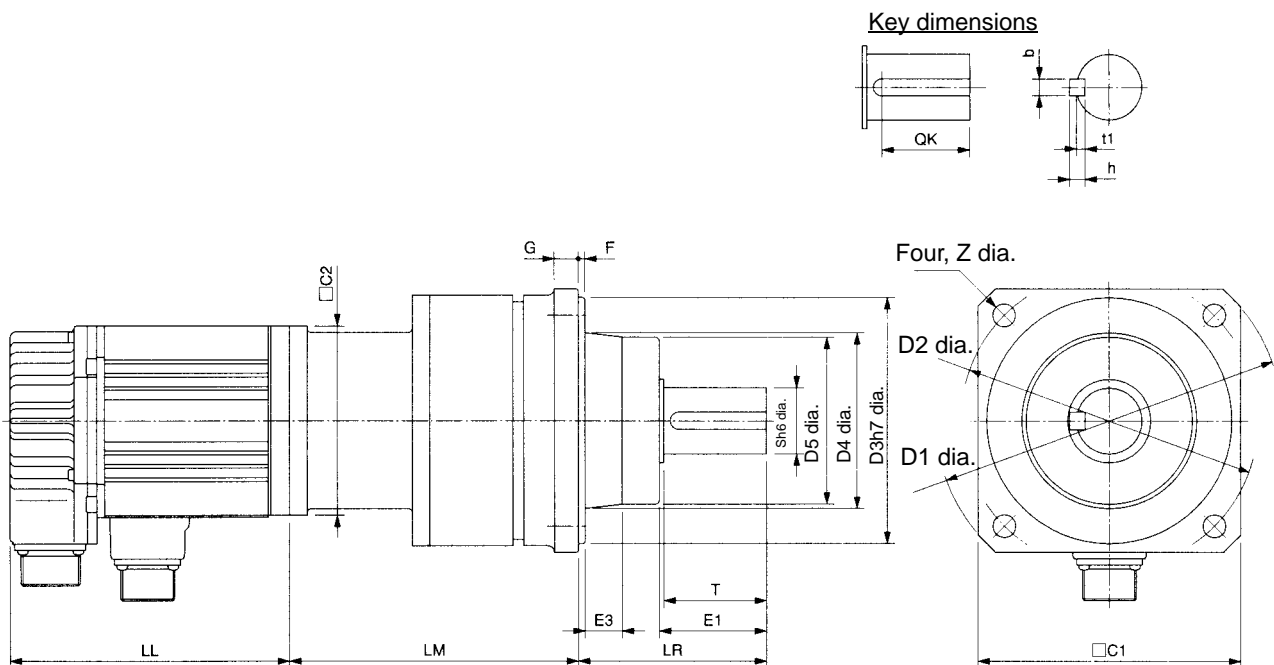

Dimensions (mm)												Model		
E1	E3	F	G	S	T	Z	IE	Key dimensions						
								QK	b	h	t1			
57	20	3	12	35	55	12	—	47	10	8	5	300 W	1/5	R88M-W30010□-□G05BJ
57	20	3	12	35	55	12	—	47	10	8	5		1/9	R88M-W30010□-□G09BJ
57	20	3	12	35	55	12	—	47	10	8	5		1/20	R88M-W30010□-□G20BJ
77	33	5	15	50	75	12	137	65	14	9	5.5		1/29	R88M-W30010□-□G29BJ
77	33	5	15	50	75	12	137	65	14	9	5.5		1/45	R88M-W30010□-□G45BJ
57	20	3	12	35	55	12	—	47	10	8	5	600 W	1/5	R88M-W60010□-□G05BJ
57	20	3	12	35	55	12	—	47	10	8	5		1/9	R88M-W60010□-□G09BJ
77	33	5	15	50	75	12	137	65	14	9	5.5		1/20	R88M-W60010□-□G20BJ
77	33	5	15	50	75	12	137	65	14	9	5.5		1/29	R88M-W60010□-□G29BJ
92	38	5	18	60	90	14	171	78	18	11	7		1/45	R88M-W60010□-□G45BJ
57	20	3	12	35	55	12	—	47	10	8	5	900 W	1/5	R88M-W90010□-□G05BJ
77	33	5	15	50	75	12	137	65	14	9	5.5		1/9	R88M-W90010□-□G09BJ
77	33	5	15	50	75	12	137	65	14	9	5.5		1/20	R88M-W90010□-□G20BJ
92	38	5	18	60	90	14	171	78	18	11	7		1/29	R88M-W90010□-□G29BJ
92	38	5	18	60	90	14	171	78	18	11	7		1/45	R88M-W90010□-□G45BJ
77	33	5	15	50	75	12	137	65	14	9	5.5	1.2 kW	1/5	R88M-W1K210□-□G05BJ
77	33	5	15	50	75	12	137	65	14	9	5.5		1/9	R88M-W1K210□-□G09BJ
92	38	5	18	60	90	14	171	78	18	11	7		1/20	R88M-W1K210□-□G20BJ
92	38	5	18	60	90	14	171	78	18	11	7		1/29	R88M-W1K210□-□G29BJ
92	38	5	18	60	90	14	171	78	18	11	7		1/45	R88M-W1K210□-□G45BJ
77	33	5	15	50	75	12	137	65	14	9	5.5	2 kW	1/5	R88M-W2K010□-□G05BJ
77	33	5	15	50	75	12	137	65	14	9	5.5		1/9	R88M-W2K010□-□G09BJ
92	38	5	18	60	90	14	171	78	18	11	7	3 kW	1/20	R88M-W2K010□-□G20BJ
92	38	5	18	60	90	14	171	78	18	11	7		1/5	R88M-W3K010□-□G05BJ
92	38	5	18	60	90	14	171	78	18	11	7		1/9	R88M-W3K010□-□G11BJ

Diagram 2

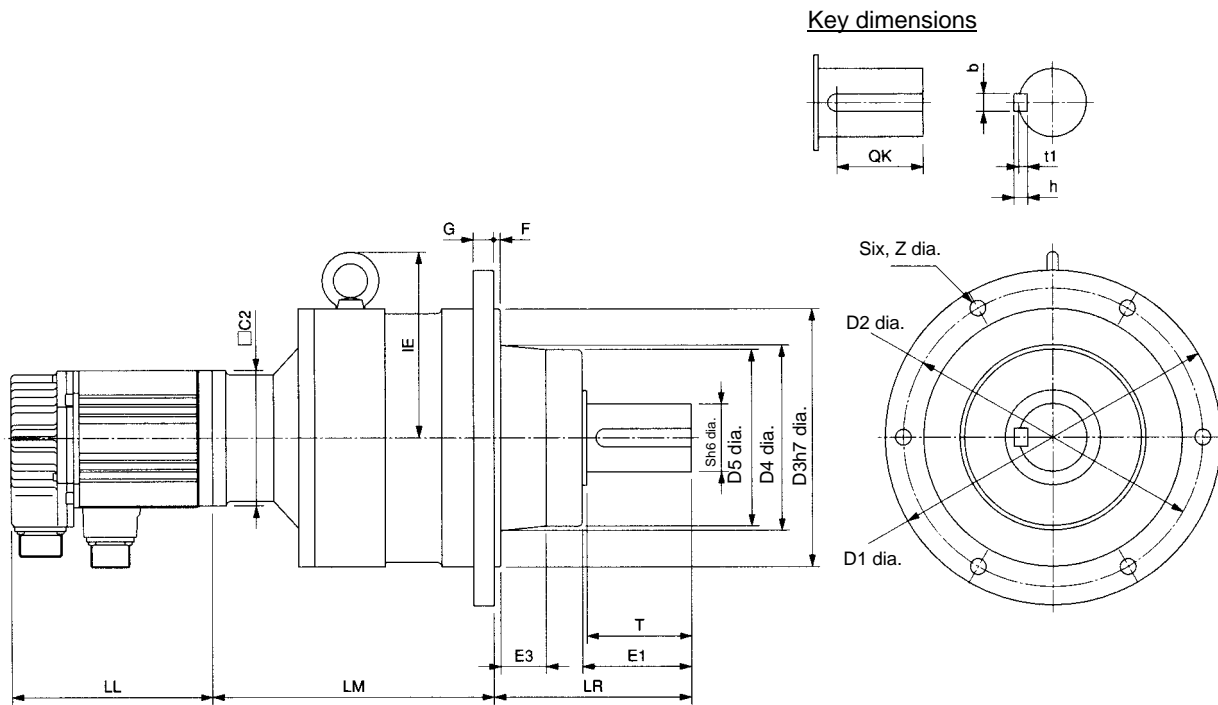

• 1,500-r/min Servomotors (450 W to 4.4 kW) with Standard Gears

Model			Diagram No.	Dimensions (mm)										
				LL		LM	LR	C1	C2	D1	D2	D3	D4	D5
				WOB*	WB*									
450 W	1/5	R88M-W45015T-□G05BJ	1	138	176	156	100	140	130	185	160	130	94	91
	1/9	R88M-W45015T-□G09BJ		138	176	168	100	140	130	185	160	130	94	91
	1/20	R88M-W45015T-□G20BJ	2	138	176	213	140	—	130	245	220	190	135	130
	1/29	R88M-W45015T-□G29BJ		138	176	213	140	—	130	245	220	190	135	130
	1/45	R88M-W45015T-□G45BJ		138	176	223	140	—	130	245	220	190	135	130
850 W	1/5	R88M-W85015T-□G05BJ	1	161	199	156	100	140	130	185	160	130	94	91
	1/9	R88M-W85015T-□G09BJ		161	199	168	100	140	130	185	160	130	94	91
	1/20	R88M-W85015T-□G20BJ	2	161	199	213	140	—	130	245	220	190	135	130
	1/29	R88M-W85015T-□G29BJ		161	199	213	140	—	130	245	220	190	135	130
	1/45	R88M-W85015T-□G45BJ		161	199	244	160	—	130	310	280	240	186	182
1.3 kW	1/5	R88M-W1K315T-□G05BJ	2	185	223	182	140	—	130	245	220	190	135	130
	1/9	R88M-W1K315T-□G09BJ		185	223	209	140	—	130	245	220	190	135	130
	1/20	R88M-W1K315T-□G20BJ		185	223	213	140	—	130	245	220	190	135	130
	1/29	R88M-W1K315T-□G29BJ		185	223	234	160	—	130	310	280	240	186	182
	1/45	R88M-W1K315T-□G45BJ		185	223	244	160	—	130	310	280	240	186	182
1.8 kW	1/5	R88M-W1K815T-□G05BJ	2	166	217	203	140	—	180	245	220	190	135	130
	1/9	R88M-W1K815T-□G09BJ		166	217	230	140	—	180	245	220	190	135	130
	1/20	R88M-W1K815T-□G20BJ		166	217	255	160	—	180	310	280	240	186	182
	1/29	R88M-W1K815T-□G29BJ		166	217	255	160	—	180	310	280	240	186	182
2.9 kW	1/5	R88M-W2K915T-□G05BJ	2	192	243	223	160	—	180	310	280	240	186	182
	1/9	R88M-W2K915T-□G09BJ		192	243	255	160	—	180	310	280	240	186	182
	1/20	R88M-W2K915T-□G20BJ		192	243	255	160	—	180	310	280	240	186	182
4.4 kW	1/5	R88M-W4K415T-□G05BJ	2	226	277	223	160	—	180	310	280	240	186	182
	1/9	R88M-W4K415T-□G09BJ		226	277	255	160	—	180	310	280	240	186	182

Note WOB and WB mean “without brake” and “with brake” respectively.

Diagram 1

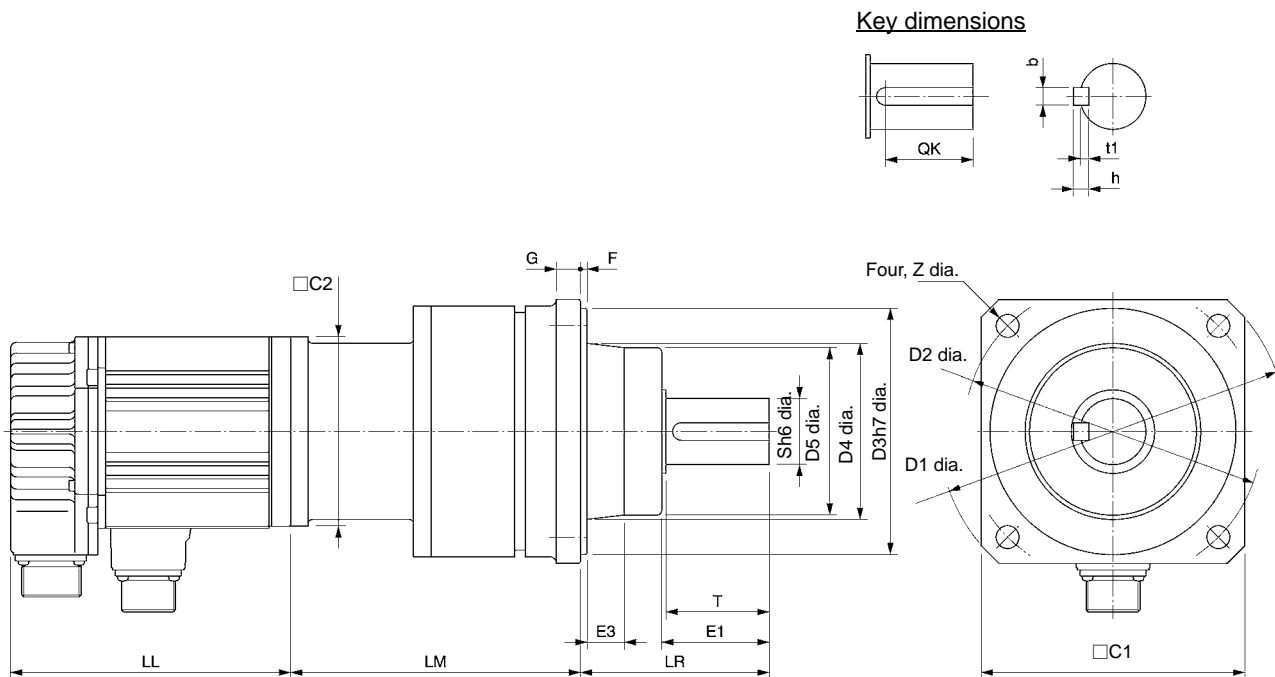

Dimensions (mm)												Model			
E1	E3	F	G	S	T	Z	IE	Key dimensions							
								QK	b	h	t1				
57	20	3	12	35	55	12	–	47	10	8	5	450 W	1/5	R88M-W45015T-□G05BJ	
57	20	3	12	35	55	12	–	47	10	8	5		1/9	R88M-W45015T-□G09BJ	
77	33	5	15	50	75	12	137	65	14	9	5.5		1/20	R88M-W45015T-□G20BJ	
77	33	5	15	50	75	12	137	65	14	9	5.5		1/29	R88M-W45015T-□G29BJ	
77	33	5	15	50	75	12	137	65	14	9	5.5		1/45	R88M-W45015T-□G45BJ	
57	20	3	12	35	55	12	–	47	10	8	5	850 W	1/5	R88M-W85015T-□G05BJ	
57	20	3	12	35	55	12	–	47	10	8	5		1/9	R88M-W85015T-□G09BJ	
77	33	5	15	50	75	12	137	65	14	9	5.5		1/20	R88M-W85015T-□G20BJ	
77	33	5	15	50	75	12	137	65	14	9	5.5		1/29	R88M-W85015T-□G29BJ	
77	33	5	15	50	75	12	137	65	14	9	5.5		1/45	R88M-W85015T-□G45BJ	
92	38	5	18	60	90	14	171	78	18	11	7	1.3 kW	1/5	R88M-W1K315T-□G05BJ	
77	33	5	15	50	75	12	137	65	14	9	5.5		1/9	R88M-W1K315T-□G09BJ	
77	33	5	15	50	75	12	137	65	14	9	5.5		1/20	R88M-W1K315T-□G20BJ	
92	38	5	18	60	90	14	171	78	18	11	7		1/29	R88M-W1K315T-□G29BJ	
92	38	5	18	60	90	14	171	78	18	11	7		1/45	R88M-W1K315T-□G45BJ	
77	33	5	15	50	75	12	137	65	14	9	5.5	1.8 kW	1/5	R88M-W1K815T-□G05BJ	
77	33	5	15	50	75	12	137	65	14	9	5.5		1/9	R88M-W1K815T-□G09BJ	
92	38	5	18	60	90	14	171	78	18	11	7		1/20	R88M-W1K815T-□G20BJ	
92	38	5	18	60	90	14	171	78	18	11	7		1/29	R88M-W1K815T-□G29BJ	
92	38	5	18	60	90	14	171	78	18	11	7		2.9 kW	1/5	R88M-W2K915T-□G05BJ
92	38	5	18	60	90	14	171	78	18	11	7	1/9		R88M-W2K915T-□G09BJ	
92	38	5	18	60	90	14	171	78	18	11	7	1/20		R88M-W2K915T-□G20BJ	
92	38	5	18	60	90	14	171	78	18	11	7	4.4 kW		1/5	R88M-W4K415T-□G05BJ
92	38	5	18	60	90	14	171	78	18	11	7			1/9	R88M-W4K415T-□G09BJ

Diagram 2

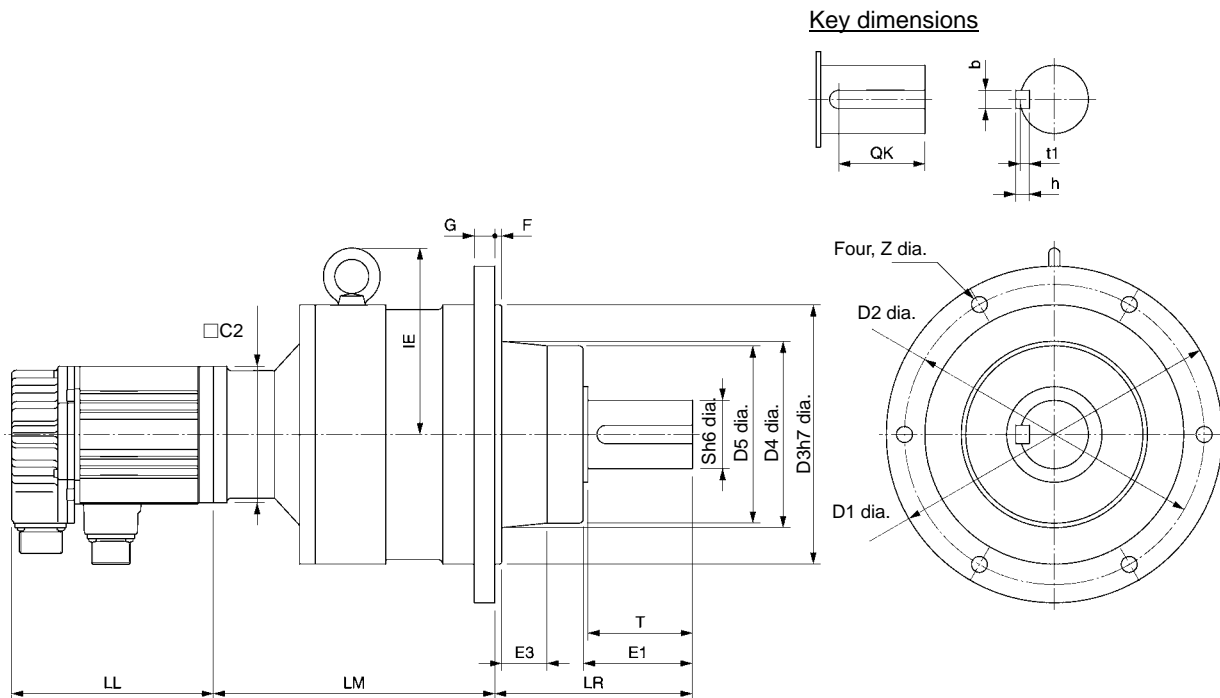

■ AC Servomotors with Economy Gears

● 3,000-r/min Servomotors (100 to 750 W) with Economy Reduction Gears

Model			#	Dimensions (mm)															Key dimensions				
				LL		LM	LR	C1	C2	D2	D3	D4	E1	E3	F	S	T	Z	ℓ	QK	b	h	t1
				WOB*	WB*																		
100 W	1/5	R88M-W10030□ -□G05CJ	1	94.5	135	67.5	32	52	40	60	50	45	22	10	3	12	20	M5	12	16	4	4	2.5
		R88M-W10030□ -□G09CJ		94.5	135	67.5	32	52	40	60	50	45	22	10	3	12	20	M5	12	16	4	4	2.5
	R88M-W10030□ -□G15CJ	94.5		135	78	32	52	40	60	50	45	22	10	3	12	20	M5	12	16	4	4	2.5	
	R88M-W10030□ -□G25CJ	94.5		135	92	50	78	40	90	70	62	33	17	3	19	30	M6	20	22	6	6	3.5	
200 W	1/5	R88M-W20030□ -□G05CJ	2	96.5	136	72.5	32	52	60	60	50	45	22	10	3	12	20	M5	12	16	4	4	2.5
		R88M-W20030□ -□G09CJ		96.5	136	89.5	50	78	60	90	70	62	33	17	3	19	30	M6	20	22	6	6	3.5
	R88M-W20030□ -□G15CJ	96.5		136	100	50	78	60	90	70	62	33	17	3	19	30	M6	20	22	6	6	3.5	
	R88M-W20030□ -□G25CJ	96.5		136	100	50	78	60	90	70	62	33	17	3	19	30	M6	20	22	6	6	3.5	
400 W	1/5	R88M-W40030□ -□G05CJ	2	124.5	164	89.5	50	78	60	90	70	62	33	17	3	19	30	M6	20	22	6	6	3.5
		R88M-W40030□ -□G09CJ		124.5	164	89.5	50	78	60	90	70	62	33	17	3	19	30	M6	20	22	6	6	3.5
	R88M-W40030□ -□G15CJ	124.5		164	100	50	78	60	90	70	62	33	17	3	19	30	M6	20	22	6	6	3.5	
	R88M-W40030□ -□G25CJ	124.5		164	104	61	98	60	115	90	75	43	18	5	24	40	M8	20	30	8	7	4	
750 W	1/5	R88M-W75030□ -□G05CJ	2	145	189.5	93.5	50	78	80	90	70	62	33	17	3	19	30	M6	20	22	6	6	3.5
		R88M-W75030□ -□G09CJ		145	189.5	97.5	61	98	80	115	90	75	43	18	5	24	40	M8	20	30	8	7	4
	R88M-W75030□ -□G15CJ	145		189.5	110	61	98	80	115	90	75	43	18	5	24	40	M8	20	30	8	7	4	
	R88M-W75030□ -□G25CJ	145		189.5	135	75	125	80	135	110	98	58	17	5	32	55	M10	20	45	10	8	5	

Note WOB and WB mean “without brake” and “with brake” respectively.

Diagram 1

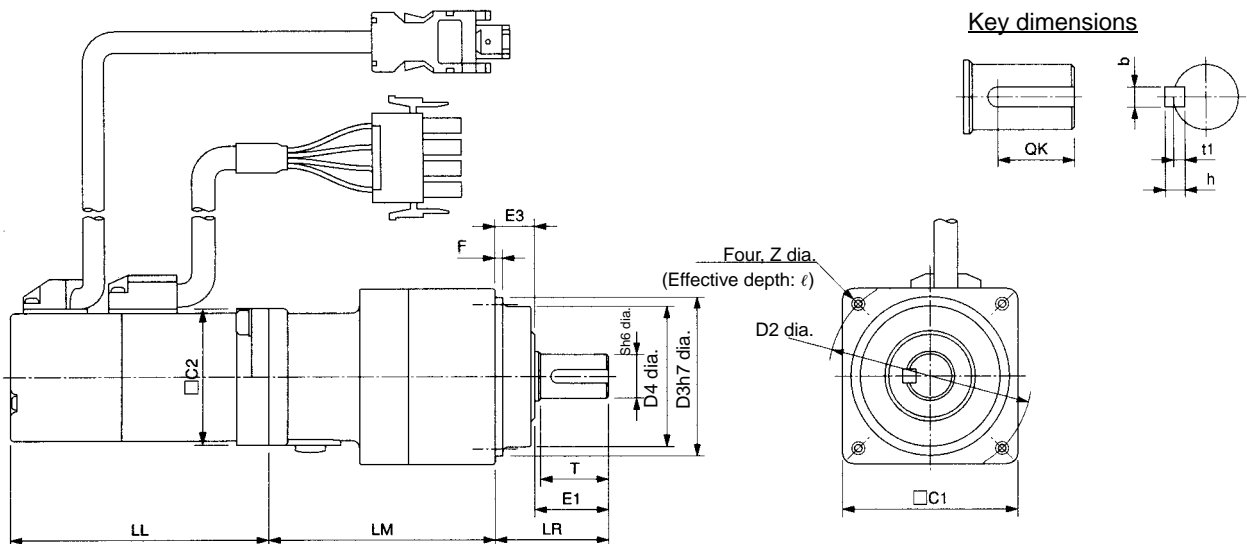
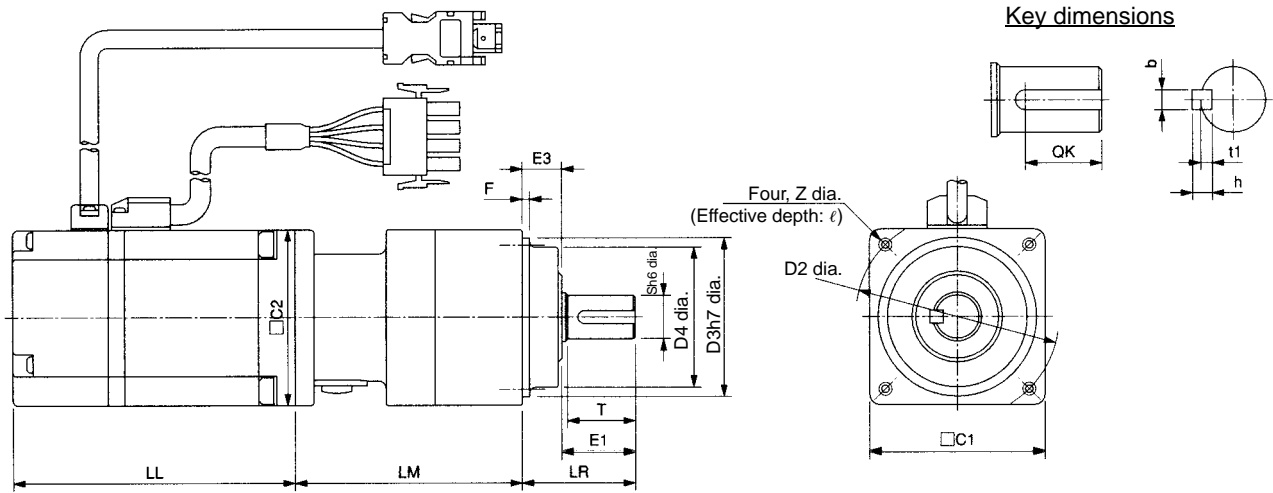

Diagram 2



● 3,000-r/min Flat-style Servomotors (100 to 750 W) with Economy Gears

Model			Dimensions (mm)																			
			LL		LM	LR	C1	C2	D2	D3	D4	E1	E3	F	S	T	Z	ℓ	Key dimensions			
			WOB*	WB*															QK	b	h	t1
100 W	1/5	R88M-WP10030 □-□G05CJ	62	91	72.5	32	52	60	60	50	45	22	10	3	12	20	M5	12	16	4	4	2.5
	1/9	R88M-WP10030 □-□G09CJ	62	91	72.5	32	52	60	60	50	45	22	10	3	12	20	M5	12	16	4	4	2.5
	1/15	R88M-WP10030 □-□G15CJ	62	91	78	32	52	60	60	50	45	22	10	3	12	20	M5	12	16	4	4	2.5
	1/25	R88M-WP10030 □-□G25CJ	62	91	92	50	78	60	90	70	62	33	17	3	19	30	M6	20	22	6	6	3.5
200 W	1/5	R88M-WP20030 □-□G05CJ	67	98.5	72.5	32	52	80	60	50	45	22	10	3	12	20	M5	12	16	4	4	2.5
	1/9	R88M-WP20030 □-□G09CJ	67	98.5	89.5	50	78	80	90	70	62	33	17	3	19	30	M6	20	22	6	6	3.5
	1/15	R88M-WP20030 □-□G15CJ	67	98.5	100	50	78	80	90	70	62	33	17	3	19	30	M6	20	22	6	6	3.5
	1/25	R88M-WP20030 □-□G25CJ	67	98.5	100	50	78	80	90	70	62	33	17	3	19	30	M6	20	22	6	6	3.5
400 W	1/5	R88M-WP40030 □-□G05CJ	87	118.5	89.5	50	78	80	90	70	62	33	17	3	19	30	M6	20	22	6	6	3.5
	1/9	R88M-WP40030 □-□G09CJ	87	118.5	89.5	50	78	80	90	70	62	33	17	3	19	30	M6	20	22	6	6	3.5
	1/15	R88M-WP40030 □-□G15CJ	87	118.5	100	50	78	80	90	70	62	33	17	3	19	30	M6	20	22	6	6	3.5
	1/25	R88M-WP40030 □-□G25CJ	87	118.5	104	61	98	80	115	90	75	43	18	5	24	40	M8	20	30	8	7	4
750 W	1/5	R88M-WP75030 □-□G05CJ	86.5	120	93.5	50	78	120	90	70	62	33	17	3	19	30	M6	20	22	6	6	3.5
	1/9	R88M-WP75030 □-□G09CJ	86.5	120	97.5	61	98	120	115	90	75	43	18	5	24	40	M8	20	30	8	7	4
	1/15	R88M-WP75030 □-□G15CJ	86.5	120	110	61	98	120	115	90	75	43	18	5	24	40	M8	20	30	8	7	4
	1/25	R88M-WP75030 □-□G25CJ	86.5	120	135	75	125	120	135	110	98	58	17	5	32	55	M10	20	45	10	8	5

Note WOB and WB mean “without brake” and “with brake,” respectively.

Diagram

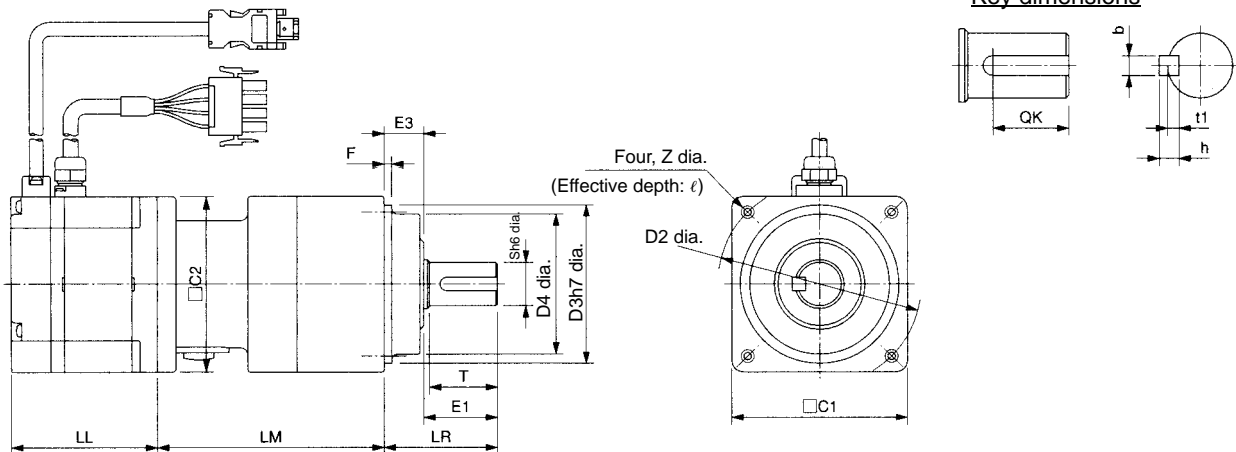

2-4 Servo Driver Specifications

■ OMNUC W-series AC Servo Drivers (R88D-WT□)

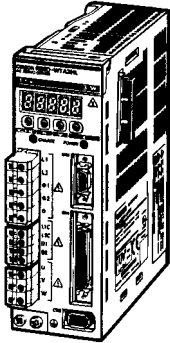

Referring to 2-2 Servo Driver and Servomotor Combinations, select a Servo Driver to match the Servomotor that is being used.

OMNUC W-series AC Servomotor Drivers can handle either pulse inputs or analog inputs. The control mode is switched to match the controller being used. (The default setting is for position control by pulse train commands.)

2-4-1 General Specifications

Item		Specifications
Ambient operating temperature		0 to 55°C
Ambient operating humidity		90% max. (with no condensation)
Ambient storage temperature		-20 to 85°C
Ambient storage humidity		90% max. (with no condensation)
Storage and operating atmosphere		No corrosive gasses.
Vibration resistance		10 to 55 Hz in X, Y, and Z directions with 0.1-mm double amplitude; acceleration: 4.9 m/s ² max.
Impact resistance		Acceleration 19.6 m/s ² max., in X, Y, and Z directions, three times
Insulation resistance		Between power line terminals and case: 0.5 MΩ min. (at 500 V DC)
Dielectric strength		Between power line terminals and case: 1,500 V AC for 1 min at 50/60 Hz Between each control signal and case: 500 V AC for 1 min
Protective structure		Built into panel (IP10).
EC directives	EMC directive	EN55011 class A group1 EN61000-6-2
	Low-voltage directive	EN50178
UL standards		UL508C
cUL standards		cUL C22.2 No.14

Note 1. The above items reflect individual evaluation testing. The results may differ under compound conditions.

Note 2. Absolutely do not conduct a withstand voltage test with a Megger tester on the Servo Driver. If such tests are conducted, internal elements may be damaged.

Note 3. Depending on the operating conditions, some Servo Driver parts will require maintenance. Refer to 5-5 Periodic Maintenance for details.

Note 4. The service life of the Servo Driver is 50,000 hours at an average ambient temperature of 40°C at 80% of the rated torque.

2-4-2 Performance Specifications

■ Control Specifications

● 100-V AC Input Type

Item			R88D-WTA3HL	R88D-WTA5HL	R88D-WT01HL	R88D-WT02HL
Continuous output current (rms)			0.66 A	0.95 A	2.4 A	3.0 A
Momentary maximum output current (rms)			2.0 A	2.9 A	7.2 A	9.0 A
Input power supply	Main circuits		Single-phase 100/115 V AC (85 to 127 V) 50/60 Hz			
	Control circuits		Single-phase 100/115 V AC (85 to 127 V) 50/60 Hz			
Heating value	Main circuits		3.5 W	5.2 W	12 W	16.4 W
	Control circuits		13 W	13 W	13 W	13 W
Control method			All-digital servo			
Inverter method			PWM method based on IGBT			
PWM frequency			11.7 kHz			
Weight			Approx. 0.8 kg	Approx. 0.8 kg	Approx. 0.8 kg	Approx. 1.1 kg
Maximum applicable Servomotor wattage			30 W	50 W	100 W	200 W
Applicable Servomotor (R88M-)	3,000-r/min	[Incremental]	W03030L	W05030L	W10030L	W20030L
		[Absolute]	W03030S	W05030S	W10030S	W20030S
	3,000-r/min Flat-style	[Incremental]	–	–	WP10030L	WP20030L
		[Absolute]	–	–	WP10030S	WP20030S
	1,000-r/min	[Incremental]	–	–	–	–
		[Absolute]	–	–	–	–
1,500-r/min	[Absolute]	–	–	–	–	
Performance	Speed control range		1:5,000			
	Load fluctuation rate		0.01% max. at 0% to 100% (at rated rotation speed)			
	Voltage fluctuation rate		0% at rated voltage $\pm 10\%$ (at rated rotation speed)			
	Temperature fluctuation rate		$\pm 0.1\%$ max. at 0 to $+50^{\circ}\text{C}$ (at rated rotation speed)			
	Frequency characteristics		400 Hz (at the same load as the rotor inertia)			
	Torque control repeatability		$\pm 2\%$			

● 200-V AC Input Type (Single-phase Input)

Item		R88D-WTA3H	R88D-WTA5H	R88D-WT01H	R88D-WT02H	R88D-WT04H	
Continuous output current (rms)		0.44 A	0.64 A	0.91 A	2.1 A	2.8 A	
Momentary maximum output current (rms)		1.3 A	2.0 A	2.8 A	6.5 A	8.5 A	
Input power supply	Main circuits	Single-phase 200/230 V AC (170 to 253 V) 50/60 Hz					
	Control circuits	Single-phase 200/230 V AC (170 to 253 V) 50/60 Hz					
Heating value	Main circuits	3.1 W	4.6 W	6.7 W	13.3 W	20 W	
	Control circuits	13 W	13 W	13 W	13 W	13 W	
PWM frequency		11.7 kHz					
Weight		Approx. 0.8 kg	Approx. 0.8 kg	Approx. 0.8 kg	Approx. 0.8 kg	Approx. 1.1 kg	
Applicable Servomotor wattage		30 W	50 W	100 W	200 W	400 W	
Applicable Servomotor (R88M-)	3,000-r/min	[Incremental]	W03030H	W05030H	W10030H	W20030H	W40030H
		[Absolute]	W03030T	W05030T	W10030T	W20030T	W40030T
	3,000-r/min Flat-style	[Incremental]	–	–	WP10030H	WP20030H	WP40030H
		[Absolute]	–	–	WP10030T	WP20030T	WP40030T
	1,000-r/min	[Incremental]	–	–	–	–	–
		[Absolute]	–	–	–	–	–
1,500-r/min	[Absolute]	–	–	–	–	–	
Control method		All-digital servo					
Inverter method		PWM method based on IGBT					
Performance	Speed control range	1:5,000					
	Load fluctuation rate	0.01% max. at 0% to 100% (at rated rotation speed)					
	Voltage fluctuation rate	0% at rated voltage ±10% (at rated rotation speed)					
	Temperature fluctuation rate	±0.1% max. at 0 to +50°C (at rated rotation speed)					
	Frequency characteristics	400 Hz (at the same load as the rotor inertia)					
	Torque control repeatability	±2%					

● 200-V AC Input Type (Three-phase Input)

Item		R88D-WT05H	R88D-WT08H	R88D-WT10H	R88D-WT15H	R88D-WT20H	R88D-WT30H	R88D-WT50H	R88D-WT60H	R88D-WT75H	R88D-WT150H	
Continuous output current (rms)		3.8 A	5.7 A	7.6 A	11.6 A	18.5 A	24.8 A	32.9 A	46.9 A	54.7 A	78 A	
Momentary maximum output current (rms)		11.0 A	13.9 A	17 A	28 A	42 A	56 A	84 A	110 A	130 A	170 A	
Input power supply	Main circuits	Three-phase 200/230 V AC (170 to 253 V) 50/60 Hz (See note.)										
	Control circuits	Single-phase 200/230 V AC (170 to 253 V) 50/60 Hz										
Heating value	Main circuits	27 W	41 W	55 W	123 W	120 W	155 W	240 W	290 W	330 W	490 W	
	Control circuits	15 W	15 W	15 W	15 W	15 W	15 W	15 W	27 W	27 W	30 W	
PWM frequency		11.7 kHz		3.9 kHz								
Weight		Approx. 1.7 kg	Approx. 1.7 kg	Approx. 1.7 kg	Approx. 2.8 kg	Approx. 3.8 kg	Approx. 3.8 kg	Approx. 5.5 kg	Approx. 15 kg	Approx. 15 kg	Approx. 26 kg	
Applicable Servomotor wattage		500 W	750 W	1 kW	1.5 kW	2 kW	3 kW	5 kW	6 kW	7.5 kW	15 kW	
Applicable Servomotor (R88M-)	3,000-r/min	[Incremental]	–	W75030H	W1K030H	W1K530H	W2K030H	W3K030H	W4K030H	W5K030H	–	
		[Absolute]	–	W75030T	W1K030T	W1K530T	W2K030T	W3K030T	W4K030T	W5K030T	–	
	3,000-r/min Flat-style	[Incremental]	–	WP75030H	–	WP1K530H	–	–	–	–	–	
		[Absolute]	–	WP75030T	–	WP1K530T	–	–	–	–	–	
	1,000-r/min	[Incremental]	W30010H	W60010H	W90010H	W1K210H	W2K010H	W3K010H	W4K010H	W5K510H	–	
		[Absolute]	W30010T	W60010T	W90010T	W1K210T	W2K010T	W3K010T	W4K010T	W5K510T	–	
	1,500-r/min	[Absolute]	W45015T	–	W85015T	W1K315T	W1K815T	W2K915T	W4K415T	W5K515T	W7K515T	
											W11K015T	W15K015T
Control method		All-digital servo										
Inverter method		PWM method based on IGBT										

Item		R88D-WT05H	R88D-WT08H	R88D-WT10H	R88D-WT15H	R88D-WT20H	R88D-WT30H	R88D-WT50H	R88D-WT60H	R88D-WT75H	R88D-WT150H	
Performance	Speed control range	1:5,000										
	Load fluctuation rate	0.01% max. at 0% to 100% (at rated rotation speed)										
	Voltage fluctuation rate	0% at rated voltage $\pm 10\%$ (at rated rotation speed)										
	Temperature fluctuation rate	$\pm 0.1\%$ max. at 0 to $+50^{\circ}\text{C}$ (at rated rotation speed)										
	Frequency characteristics	400 Hz (at the same load as the rotor inertia)										
	Torque control repeatability	$\pm 2\%$										

Note The input power specifications when using an R88D-WT08H with single-phase 200-V power supply are single-phase 220 to 230 V AC $+10$ to -15% , 50/60 Hz.
For details, refer to 6-3 Single-phase Power for 3,000-r/min (750-W) Servomotors.

■ Protective and Diagnostic Functions

Error detection function	Contents
Parameter corruption	The checksum for the parameters read from the EEP-ROM does not match.
Main circuit detection error	There is an error in the detection data for the power supply circuit.
Parameter setting error	Incorrect parameter setting.
Motor Mismatch	The Servomotor does not match the Servo Driver.
Overcurrent	Overcurrent detected, or improper radiation shield temperature rise detected.
Regeneration error	Regeneration circuit damaged due to large amount of regenerative energy.
Regeneration resistor overload	Regenerative energy exceeded the regeneration resistance.
Main circuit power supply setting error (See note 1.)	The method set in Pn001.2 (AC/DC input selection) is different from the AC/DC wiring method of the main circuit power supply.
Overvoltage	Main circuit DC voltage above the allowable range.
Low voltage	Main circuit DC voltage below the allowable range.
Overspeed	Servomotor rotation speed exceeded the maximum speed.
Overload	Detected at reverse limit characteristics when 245% of the rated torque was exceeded. Detected at reverse limit characteristics for 120% to 245% of the rated torque.
Dynamic brake overload	Regenerative energy exceeded the dynamic brake resistance during dynamic brake operation.
Resistor for inrush current overload	Inrush current exceeded the inrush resistance during power supply inrush.
Overheat	Abnormal temperature rise detected in radiation shield.
Backup error [Absolute]	Encoder backup power supply dropped.
Checksum error [Absolute]	Checksum error for Encoder memory data.
Battery error [Absolute]	Encoder battery voltage dropped (to 2.7 V or lower).
Absolute error	Encoder internal data error

Error detection function	Contents
Overspeed error [Absolute]	Servomotor rotation speed exceeded 200 r/min when Encoder power was turned ON.
Encoder overheating [Absolute]	Improper Encoder temperature rise detected.
Speed command input reading error	The A/D end signal was not output from the A/D converter within a fixed time.
Torque command input reading error	The A/D end signal was not output from the A/D converter within a fixed time.
System error	A control circuit system error was detected.
Runaway detected	The Servomotor rotated in the opposite direction from the command.
Multi-turn data error [Absolute]	Absolute Encoder setup was incorrect.
Encoder communications error	No communication between the Encoder and the Servo Driver.
Encoder parameter error	The parameters in the Encoder are corrupted.
Encoder data error	Data from the Encoder is incorrect.
Multi-turn limit data mismatch [Absolute]	The multi-turn limits for the Encoder and the Servo Driver do not match.
Deviation counter overflow	Deviation counter residual pulses exceeded level set for Pn505.
Motor-load deviation over (See note 1.)	The error for the full closed-loop or semiclosed-loop encoder exceeds the number of command units set in Pn51A.
Option detection error (See note 1.)	An Option Unit has been removed.
Missing phase detected	Main-circuit power supply missing phase or disconnection detected.
Motor current error (See note 2.)	The current that flows to the Servomotor is abnormally small for the torque command from the Servo Driver.
Motor conduction error (See note 2.)	When the Servomotor is ON, the baseblock condition continues, regardless of the Servo Driver settings or external input.
Parameter Unit transmission error	Data could not be transmitted after the power was turned ON. (CPF00) Transmission timeout error (CPF01)

Note 1. These functions are supported for Servo Drivers with a software version of “r.0014” or later.

Note 2. These functions are supported for Servo Drivers with software version of “r.0037.”

2-4-3 Terminal Block Specifications

Signal	Function	Condition	
L1	Main circuits power supply input	R88D-WT□H (30 to 400 W): Single-phase 200/230 V AC (170 to 253 V AC) 50/60 Hz R88D-WT□H (500 W to 6 kW): Three-phase 200/230 V AC (170 to 253 V AC) 50/60 Hz R88D-WT□HL (30 to 200 W): Single-phase 100/115 V AC (85 to 127 V AC) 50/60 Hz	
L2			
L3			
+	Main circuit DC output (Forward)	Do not connect anything. This terminal is for the R88D-WT60H to R88D-WT150H.	
+1	DC Reactor terminal for power supply harmonic control	Normally short-circuit between +1 and +2. If harmonic control measures are required, connect a DC Reactor between +1 and +2. (This terminal is not provided in R88D-WT60H to R88D-WT150H models.)	
+2			
-	Main circuit DC output (Reverse)	Do not connect anything.	
L1C	Control circuits power supply input	R88D-WT□H: Single-phase 200/230 V AC (170 to 253 V AC) 50/60 Hz R88D-WT□HL: Single-phase 100/115 V AC (85 to 127 V AC) 50/60 Hz	
L2C			
B1	External regeneration resistance connection terminal	30 to 400 W: This terminal does not normally need to be connected. If regenerative energy is high, connect an External Regeneration Resistor between B1 and B2. 500 W to 5 kW: Short-circuit between B2 and B3. If regenerative energy is high, remove the short bar between B2 and B3 and connect an External Regeneration Resistor between B1 and B2. 6 to 15 kW: Connect an External Regeneration Resistance Unit between B1 and B2.	
B2			
B3			
U	Servomotor connection terminals	Red	These are the terminals for outputs to the Servomotor. Be sure to wire these terminals correctly.
V		White	
W		Black	
⊕		Green/ Yellow	
⊕	Frame ground	This is the ground terminal. Ground to a minimum of 100 Ω (class-3).	

2-4-4 Control I/O Specifications (CN1)

■ Control I/O and External Signals for Position Control

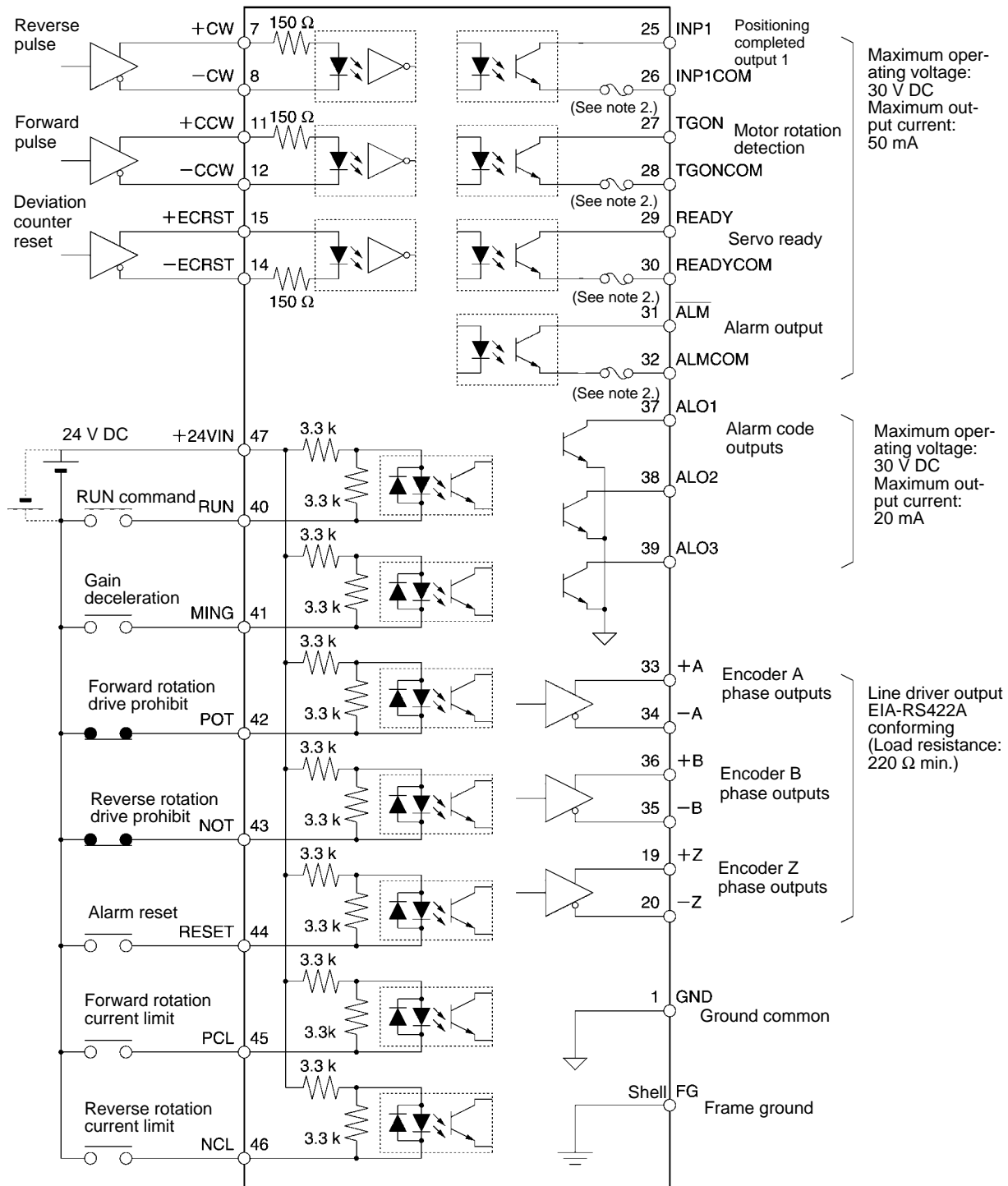

- Note 1.** The inputs at pins 40 to 46 and the outputs at pins 25 to 30 can be changed by parameter settings. The settings in the diagram are the defaults.
- Note 2.** An automatic reset fuse is provided to protect output. If the fuse is activated for overcurrent, it will automatically reset after a fixed period of time has lapsed without current flowing (supported by Servo Drivers with software version "r.0037" or later).

■ Control I/O Signal Connections and External Signal Processing for Speed and Torque Control

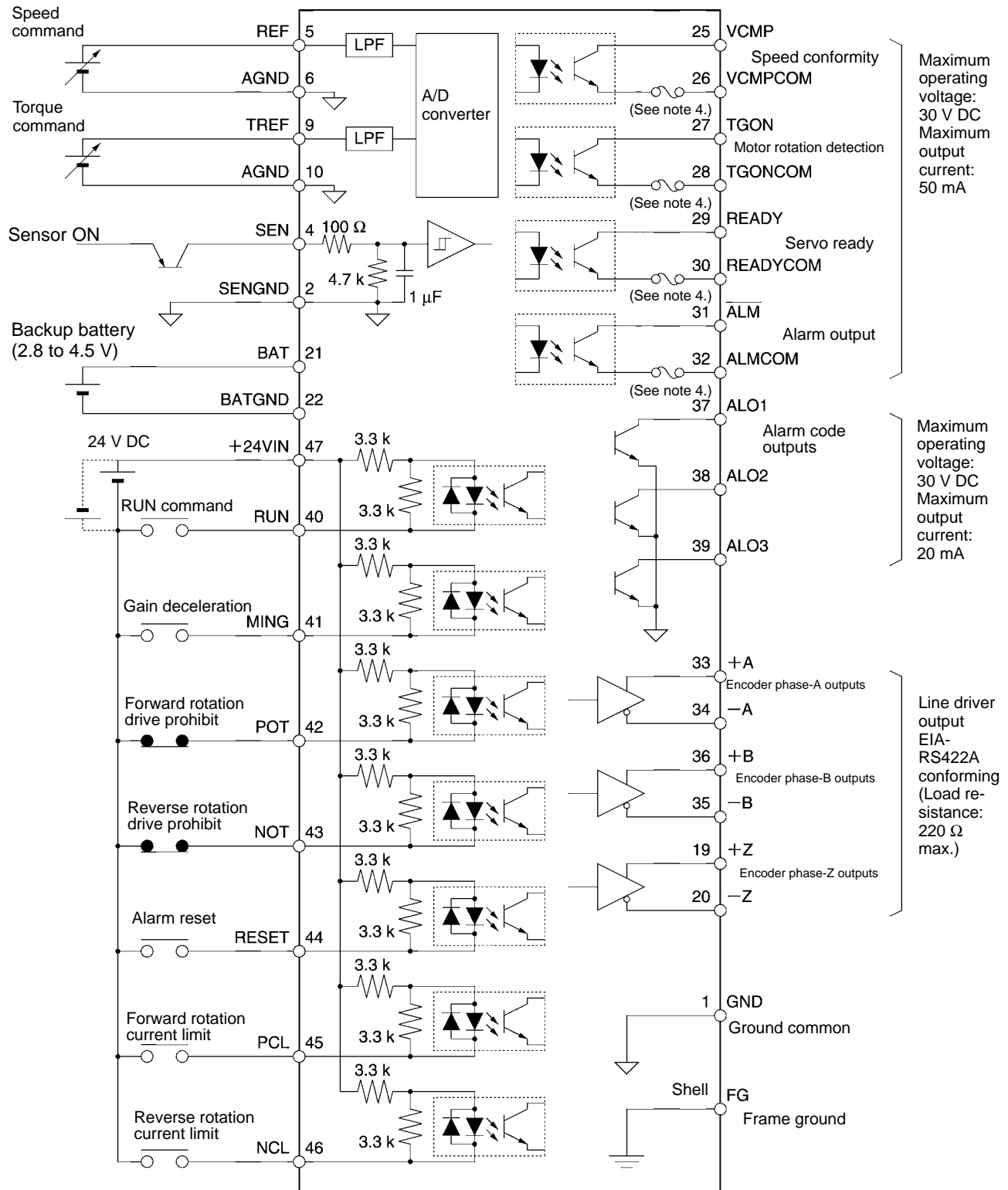

Note 1. Parameter settings (control mode selection) are required for speed and torque control.

Note 2. The inputs at pins 40 to 46 and the outputs at pins 25 to 30 can be changed by parameter settings. The settings in the diagram are the defaults.

Note 3. Pins 2, 4, 21, and 22 are for use with an absolute encoder.

Note 4. An automatic reset fuse is provided to protect output. If the fuse is activated for overcurrent, it will automatically reset after a fixed period of time has lapsed without current flowing (supported by Servo Drivers with software version “r.0037” or later).

■ Control I/O Signals

● CN1 Control Inputs

Pin No.	Signal name	Function	Contents	Control mode
5	REF	Speed command input	Analog input terminal for speed commands. ± 2 to ± 10 V (Servomotor forward rotation with + voltage) Scale can be changed by means of user parameter Pn300 (speed command scale).	All
6	AGND	Speed command input ground	Can be used as a speed limit input for torque control (by means of a Pn002.1 setting).	
9	TREF	Torque command input	Analog input terminal for torque commands. ± 1 to ± 10 V (Forward torque with + voltage) Scale can be changed by means of user parameter Pn400 (torque command scale).	All
10	AGND	Torque command input ground	Can be used as a torque limit input or torque feed forward input for speed control or position control (by means of a Pn002.0 setting).	
3 13 18	PCOM	Open collector command power supply	To use open-collector output for inputting command pulses and deviation counter resets, connect the + inputs to these terminals and connect the – inputs to open-collector output terminals.	All
7 8	+PULS/ CW/A –PULS/ CW/A	Feed pulses, reverse pulses, or 90° phase difference pulses (A phase)	Pulse string input terminals for position commands. Line-driver input: 10 mA at 3 V Maximum response frequency: 500 kpps Open-collector input: 7 to 15 mA Maximum response frequency: 200 kpps	Position
11 12	+SIGN/ CCW/B –SIGN/ CCW/B	Direction signal, forward pulses, or 90° phase difference pulses (B phase)	Any of the following can be selected by means of a Pn200.0 setting: feed pulses or direction signals (PULS/SIGN); forward or reverse pulses (CW/CCW); 90° phase difference (A/B phase) signals (A/B).	
14 15	–ECRST +ECRST	Deviation counter reset	Line-driver input: 10 mA at 3 V Open-collector input: 25 mA at 5 V ON: Pulse commands prohibited and deviation counter cleared.	Position
4 2	SEN SENGND	Sensor ON input	ON: Absolute encoder’s multi-turn amount and initial incremental pulses sent. Required when using an absolute encoder.	All [absolute]
21 22	BAT BATGND	Backup battery input	Backup battery connector terminals for power interruption for absolute encoder Connect the battery to either this terminal or CN8.	All [absolute]
47	+24VIN	+24-V power supply input for control DC	Power supply input terminal (+24 V DC) for sequence inputs (pins 40 to 46).	All

Pin No.	Signal name	Function	Contents	Control mode
40 to 46	RUN [40]	RUN command input	ON: Servo ON (Starts power to Servomotor.)	All
	MING [41]	Gain reduction input	ON: Switches speed loop to P control and reduces speed gain.	Position, speed, internally set speed
	POT [42]	Forward drive prohibit input	Forward rotation overtravel input (OFF Prohibited; ON: Permitted).	All
	NOT [43]	Reverse drive prohibit input	Reverse rotation overtravel input (OFF Prohibited; ON: Permitted).	All
	RESET [44]	Alarm reset input	ON: Servo alarm status is reset.	All
	PCL [45]	Forward rotation current limit input	ON: Output current is limited by the value set in Pn404 (forward rotation external current limit).	All
	NCL [46]	Reverse rotation current limit input	ON: Output current is limited by the value set in Pn405 (reverse rotation external current limit).	All
	RDIR [41]	Rotation direction command input	Specifies the direction of rotation for Servomotor rotation at the internally set speed. OFF: Forward rotation, ON: Reverse rotation	Internally set speed
	SPD1 [45]	Speed selection command 1 input	Selects the internally set speed (Pn301, Pn302, Pn303).	Internally set speed
	SPD2 [46]	Speed selection command 2 input		
	TVSEL [41]	Control mode switch input	ON: Change control mode	Switch control mode
	PLOCK [41]	Position lock command input	ON: Position lock goes into effect when the motor rotation speed is no more than the position lock rotation speed (Pn501).	Speed control with position lock
	IPG [41]	Pulse disable input	ON: Command pulse inputs are ignored and the motor stops.	Position control with pulse-disable
	GSEL	Gain switching input	ON: Changes gain to No.2 speed gain (Pn104, Pn105, Pn106).	Internally set speed
PSEL (See note 2.)	Command pulse factor switching input	ON: Rotates the motor using the position command pulse multiplied by the value set in Pn217 (command pulse factor). (When Pn218.0 = 1)	Position	

Note 1. Function allocations for pin 40 to 46 sequence inputs can be set by means of user parameters Pn50A to Pn50D. In this table, the numbers enclosed in brackets indicate the default pin numbers (allocations). The allocations vary depending on the control mode.

Note 2. This I/O signal is supported by Servo Drivers with software version “r.0037.”

● CN1 Control Outputs

Pin No.	Signal name	Function	Contents	Command mode
1	GND	Ground common	Ground common terminal for the encoder output and alarm code output	All
33	+A	Encoder phase-A + output	Outputs encoder pulses divided according to user parameter Pn201. Line driver output (conforming to RS-422A).	All
34	-A	Encoder phase-A - output		
36	+B	Encoder phase-B + output		
35	-B	Encoder phase-B - output		

Pin No.	Signal name	Function	Contents	Command mode
19	+Z	Encoder phase-Z + output	Outputs encoder phase-Z signals (1 pulse/revolution). Line driver output (conforming to RS-422A).	All
20	-Z	Encoder phase-Z - output		
48	+ABS	Absolute encoder signal + output	Outputs absolute encoder data. Line driver output (conforming to RS-422A).	All [absolute]
49	-ABS	Absolute encoder signal - output		
37	ALO1	Alarm code output 1	When an alarm is generated for the Servo Driver, the contents of the alarm are output in code. Open collector output: 30 V DC, 20 mA max.	All
38	ALO2	Alarm code output 2		
39	ALO3	Alarm code output 3		
31	ALM	Alarm output	When an alarm is generated for the Servo Driver, the output is OFF. Open collector output (50 mA, 30 V DC max.)	All
32	ALMCOM			
25 to 30	INP1 [25]	Positioning completed output 1	ON when the position error is within the positioning completed range (Pn500). OFF when in a control mode other than position control mode.	Position
	INP1COM [26]			
	INP2	Positioning completed output 2	ON when the position error is within the positioning completed range (Pn504). Always OFF when in a control mode other than position control mode.	Position
	INP2COM			
	VCMP [25]	Speed conformity output	ON when the Servomotor speed error is within the speed conformity signal output range (Pn503). Always OFF when in a control mode other than speed control mode.	Speed
	VCMPCOM [26]			
	TGON [27]	Servomotor rotation detection output	ON when the Servomotor rotation speed exceeds the value set for the Servomotor rotation detection speed (Pn502).	All
	TGONCOM [28]			
	READY [29]	Servo ready output	ON if no errors are discovered after powering the main circuits.	All
	READYCOM [30]			
	CLIMIT	Current limit detection output	ON if the output current is limited.	All
	CLIMITCOM			
	VLIMIT	Speed limit detection output	ON if the speed is limited. Always OFF when in a control mode other than torque control mode.	Torque
	VLIMITCOM			
	BKIR	Brake interlock output	Holding brake timing signals are output according to user parameters Pn506, Pn507, and Pn508.	All
	BKIRCOM			
	WARN	Warning output	ON when an overload warning or regeneration overload warning is detected.	All
	WARNCOM			
PSON (See note 2.)	Command pulse factor enabled output	ON when the command pulse factor has changed after the PSEL (command pulse factor switching) input has been turned ON.	Position	
PSONCOM (See note 2.)				
Shell	FG	Frame ground	Connection terminal for cable's shielded wire and FG line.	All

Note 1. Function allocations for pin 25 to 30 sequence outputs can be set by means of user parameters Pn50E to Pn510. In this table, the numbers enclosed in brackets indicate the default pin numbers (allocations). (The allocations vary depending on the control mode.)

Note 2. The interface for pin 25 to 30 sequence outputs is open-collector output (50 mA, 30 V DC max.).

Note 3. These I/O signals are supported by Servo Drivers with software version “r.0037.”

■ CN1: Pin Arrangement

2	SENGND [absolute]	Sensor ON input ground	1	GND	Ground common	26	INP1COM	Positioning completed output ground (See note 1.)
4	SEN [absolute]	Sensor ON input	3	PCOM	Open-collector command power	27	TGON	Motor rotation detection output (See note 1.)
6	AGND	Speed command input ground	5	REF	Speed command input	28	TGONCOM	Motor rotation detection output ground (See note 1.)
8	-PULS /-CW/-A	- feed pulse, - reverse pulse, - A phase	7	+PULS /+CW/+A	+ feed pulse, + reverse pulse, + A phase	29	READY	Servo ready output (See note 1.)
10	AGND	Torque command input ground	9	TREF	Torque command input	30	READYCOM	Servo ready output ground (See note 1.)
12	-SIGN /-CCW /-B	- direction signal, - forward pulse, - B phase.	11	+SIGN /+CCW/+B	+direction signal, + forward pulse, + B phase	31	ALM	Alarm output
14	-ECRST	Deviation counter reset	13	PCOM	Open-collector command power	32	ALMCOM	Alarm output ground
16		See note 2.	15	+ECRST	+ deviation counter reset	33	+A	Encoder phase-A + output
18	PCOM	Open-collector command power	17		See note 2	34	-A	Encoder phase-A - output
20	-Z	Encoder phase-Z - output	19	+Z	Encoder phase-Z + output	35	-B	Encoder phase-B - output
22	BATGND [absolute]	Backup battery - input (see note 3)	21	BAT [absolute]	Backup battery + input (See note 3.)	36	+B	Encoder phase-B + output
24		See note 2.	23		See note 2	37	AL01	Alarm code output 1
			25	INP1	Positioning completed output 1 (See note 1.)	38	AL02	Alarm code output 2
						39	AL03	Alarm code output 3
						40	RUN	RUN command input (See note 1.)
						41	MING	Gain reduction input (See note 1.)
						42	POT	Forward rotation drive prohibit input (See note 1.)
						43	NOT	Reverse rotation drive prohibit input (See note 1.)
						44	RESET	Alarm reset input (See note 1.)
						45	PCL	Forward current limit (See note 1.)
						46	NCL	Reverse current limit (See note 1.)
						47	+24VIN	Control DC +24-V input
						48	+ABS [absolute]	Absolute encoder signal + output
						49	-ABS [absolute]	Absolute encoder signal - output
						50		See note 2.

Note 1. Function allocations for pin 40 to 46 sequence inputs and pin 25 to 30 sequence outputs can be set by means of user parameters Pn50A to Pn50D, Pn513, and Pn50E to Pn510, respectively. The allocations shown in this table are the defaults.

Note 2. Do not wire the empty pins.

Note 3. When an absolute encoder is used, connect the battery (2.8 to 4.5 V) to the backup battery inputs at pins 21 and 22 or to CN8 (Battery Connector).

● **CN1 Connectors (50P)**

Servo Driver receptacle	10250-52A2JL (Sumitomo 3M)
Cable solder plug	10150-3000VE (Sumitomo 3M)
Cable case	10350-52A0-008 (Sumitomo 3M)

■ **Control Input Circuits**

● **Speed and Torque Command Inputs**

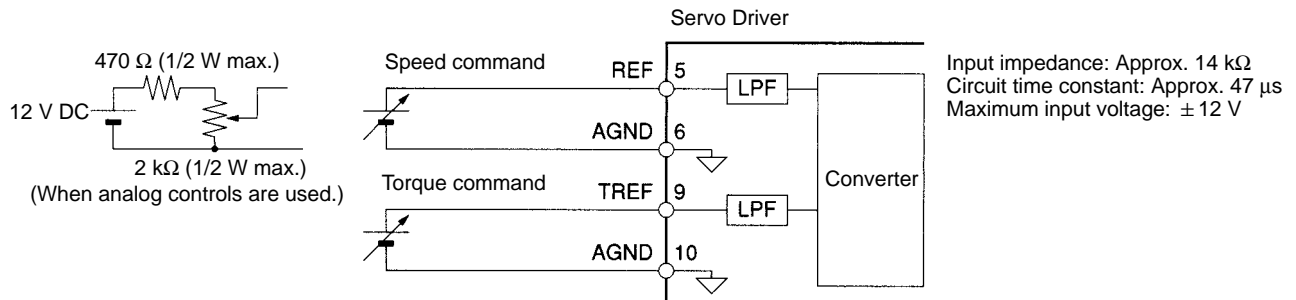

● **Position Command Pulse Inputs and Deviation Counter Reset Inputs**

Line Driver Input

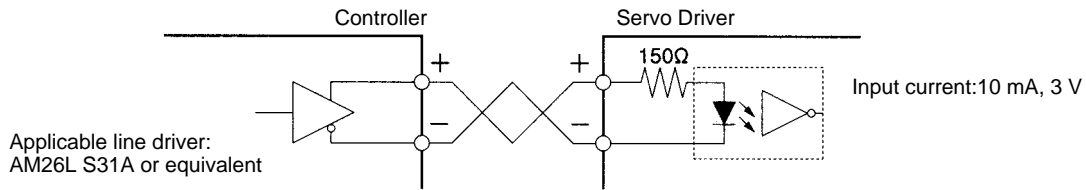

Open Collector Input

Using Power Supply for Open Collector Commands (PCOM)

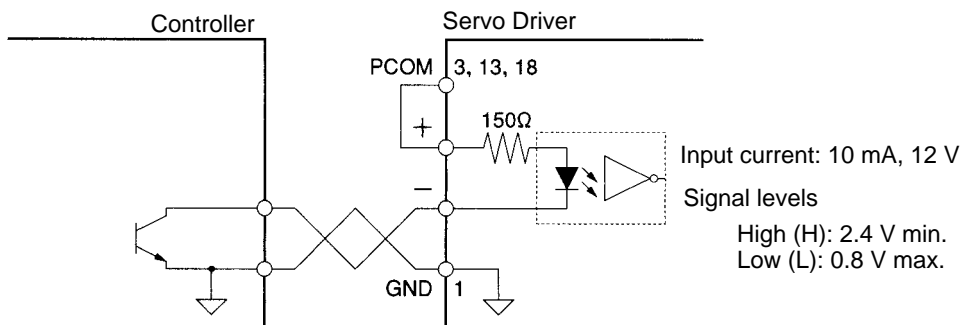

Using External Power Supply

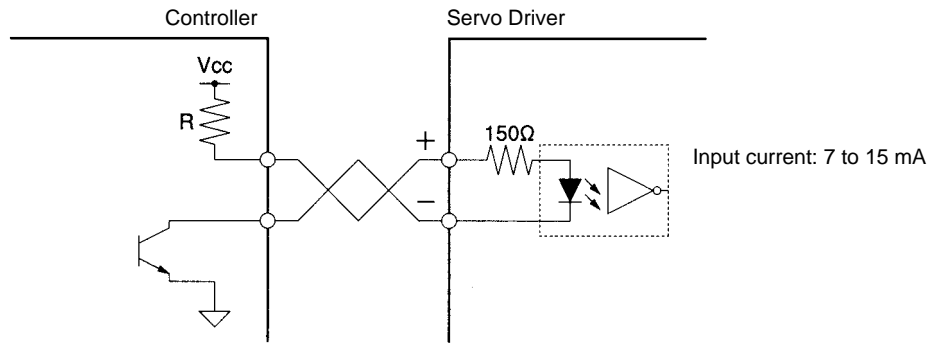

Note Select a value for resistance R so that the input current will be from 7 to 15 mA.

Vcc	R
24 V	2.2 kΩ
12 V	1 kΩ
5 V	180 Ω

• Sensor ON Inputs [Absolute]

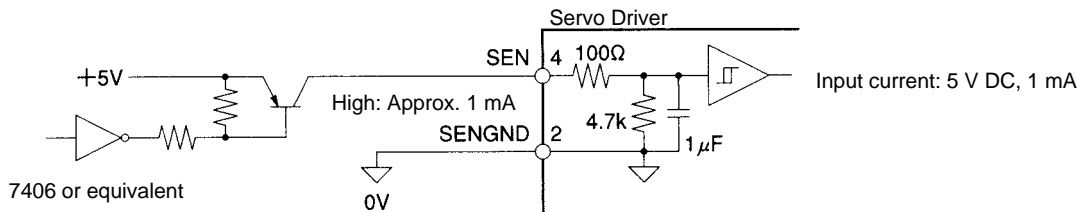

Signal Levels High: 4 V min.
Low: 0.8 V max.

Note A PNP transistor is recommended.

• Sequence Inputs

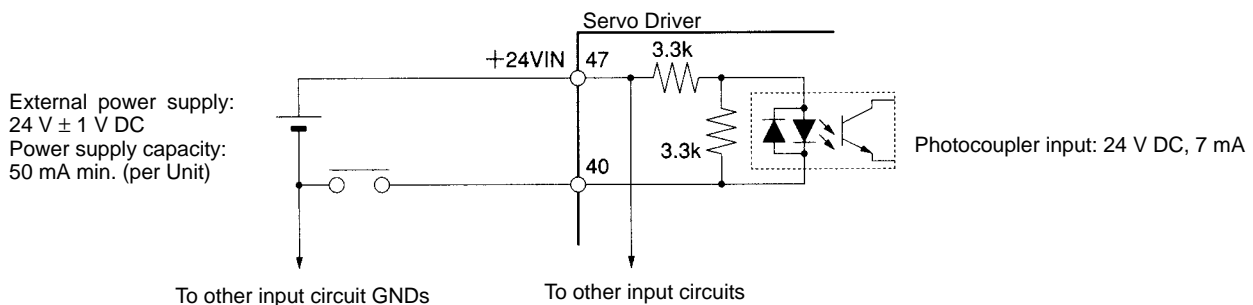

Signal Levels ON level: Minimum (+24VIN-11) V
OFF level: Maximum (+24VIN-1) V

■ Control Output Circuits

● Position Feedback Output

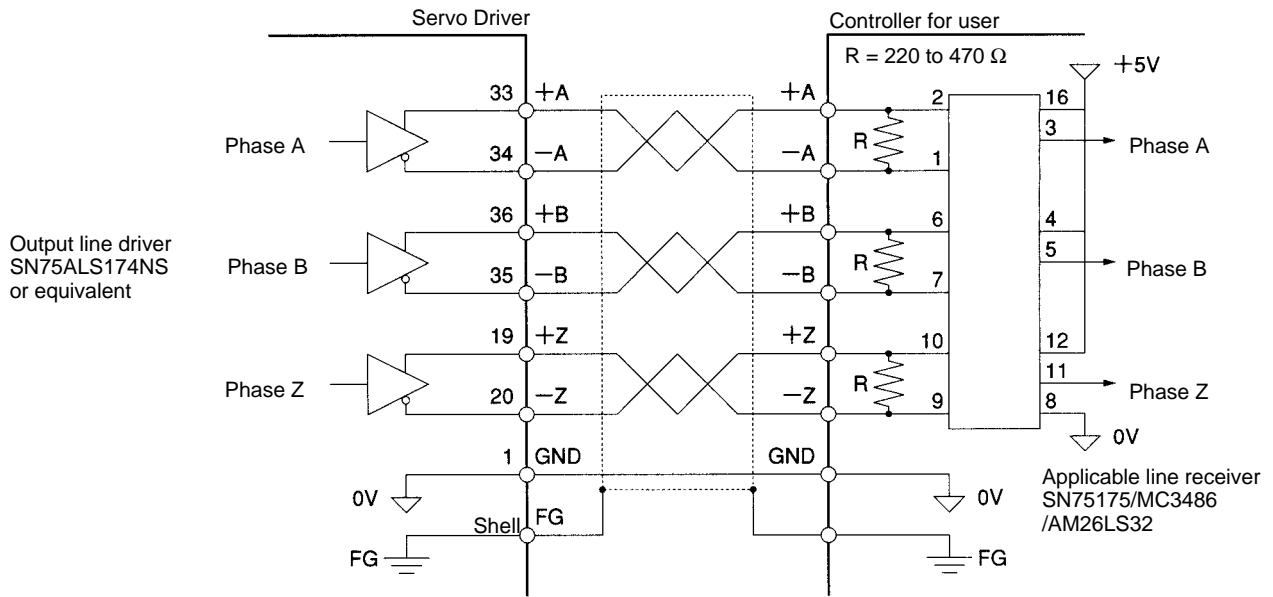

● Sequence and Alarm Outputs

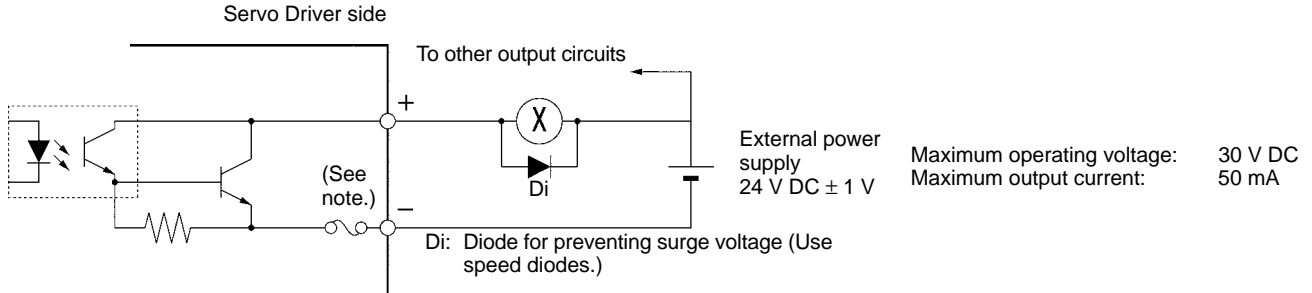

Note An automatic reset fuse is provided to protect output. If the fuse is activated for overcurrent, it will automatically reset after a fixed period of time has lapsed without current flowing (supported by Servo Drivers with software version “r.0037” or later).

● Alarm Code Outputs

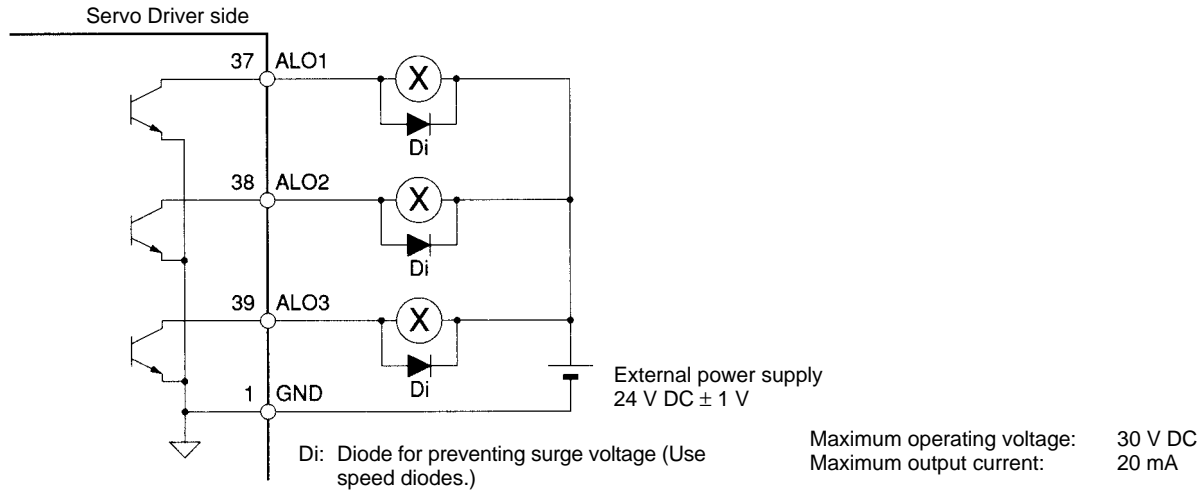

■ Control Input Details (CN1)

● 5: Speed Command Input (REF); 6: Speed Command Input Ground (AGND)

Speed Control

This is the input for speed commands. The scale of the rotation speed for REF voltage can be changed by means of user parameter Pn300 (speed command scale). The default setting is for the rated rotation speed for an input of 10 V.

Torque Control

This input becomes an analog speed limit input when Pn002.1 (speed command input change, of function selection application switch 2) is set to 1. The default setting is for the function to not be used (set value: 0). The scale of the speed limit value for speed command inputs can be changed by means of user parameter Pn300 (speed command scale).

The REF voltage is irrelevant (absolute values only).

The speed is limited to the Pn407 (speed limit) setting or the REF voltage limit, whichever is lower.

Position Control

This input becomes a speed feed forward input when Pn207.1 (speed command input change) is set to 1. The default setting is for the function to not be used (set value: 0). A speed command corresponding to the REF voltage is added to the speed loop.

● 9: Torque Command Input (TREF); 10: Torque Command Input Ground (AGND)

Torque Control

This is the input for torque commands. The scale of the output torque for TREF voltage can be changed by means of user parameter Pn400 (torque command scale). The default setting is for the rated torque for an input of 3 V.

Position and Speed Control

This input becomes an analog torque limit input (set value: 1 or 3) or a torque feed forward input (set value: 2) depending on the Pn002.0 (torque command input change, of function selection application switch 2) setting.

The scale of the torque limit value or the feed forward torque for TREF voltage can be changed by means of user parameter Pn400 (torque command scale). The default setting is for the rated torque for an input of 3 V.

Pn002.0 = 1: Analog Torque Control Input

Output values for both forward and reverse are limited by the same value, regardless of the TREF voltage polarity (the absolute value is used). See the note below.

Pn002.0 = 2: Torque Feedforward Input

A torque corresponding to the TREF voltage is added to the current loop. The TREF voltage polarity is effective.

Pn002.0 = 3: Analog Torque Limit Input when Inputting PCL and NCL

The TREF voltage polarity is ignored (the absolute value is used). When PCL (forward rotation current limit input) is input, the output torque for forward rotation is limited. When NCL (reverse rotation current limit input) is input, the output torque for reverse rotation is limited. See the note below.

Note The output torque is limited by the lowest limit value of the following torque limits: The analog torque limit according to TREF voltage, Pn402 (forward torque limit), Pn403 (reverse torque limit), Pn404 (forward rotation external current limit), and Pn405 (reverse rotation external current limit). The limit value for analog torque limit Pn402 or Pn403 (Pn002.0 = 1) are always enabled. The limit value for analog torque limit Pn404 or Pn405 (Pn002.0 = 3) is enabled when PCL or NCL is input.

- **+ Feed Pulse, +Reverse Pulse, +90° Phase Difference Pulse (A Phase)**
(7: +PULS/+CW/+A)
- **Feed Pulse, –Reverse Pulse, –90° Phase Difference Pulse (A Phase)**
(8: –PULS/–CW/–A)
- + Direction Signal, +Forward Pulse, +90° Phase Difference Pulse (B Phase)**
(11: +SIGN/+CCW/+B)
- **Direction Signal, –Forward Pulse, –90° Phase Difference Pulse (B Phase)**
(12: –SIGN/–CCW/–B)

The function of these signals depends on the setting of Pn200.0 (command pulse mode: position control setting 1).

- Pn200.0 = 0: Feed pulse and direction signal: positive logic
- Pn200.0 = 1: Forward pulse and reverse pulse: positive logic (default)
- Pn200.0 = 2: 90° Phase Difference (phases A/B) (x1), positive logic
- Pn200.0 = 3: 90° Phase Difference (phases A/B) (x2), positive logic
- Pn200.0 = 4: 90° Phase Difference (phases A/B) (x4), positive logic
- Pn200.0 = 5: Feed pulse and direction signal: negative logic
- Pn200.0 = 6: Forward pulse and reverse pulse: negative logic
- Pn200.0 = 7: 90° Phase Difference (phases A/B) (x1), negative logic
- Pn200.0 = 8: 90° Phase Difference (phases A/B) (x2), negative logic
- Pn200.0 = 9: 90° Phase Difference (phases A/B) (x4), negative logic

Logic	Pn200.0 setting	Command pulse mode	Input pins	Servomotor forward command	Servomotor reverse command
Positive	0	Feed pulse and direction signal	7: +PULS 8: -PULS 11: +SIGN 12: -SIGN		
	1	Reverse pulse and forward pulse	7: +CW 8: -CW 11: +CCW 12: -CCW		
	2	90° phase difference signals (x1)	7: +A 8: -A 11: +B 12: -B		
	3	90° phase difference signals (x2)			
4	90° phase difference signals (x4)				
Negative	5	Feed pulse and direction signal	7: +PULS 8: -PULS 11: +SIGN 12: -SIGN		
	6	Reverse pulse and forward pulse	7: +CW 8: -CW 11: +CCW 12: -CCW		
	7	90° phase difference signals (x1)	7: +A 8: -A 11: +B 12: -B		
	8	90° phase difference signals (x2)			
	9	90° phase difference signals (x4)			

Command Pulse Timing

The following wave forms are for positive logic. Conditions are the same for negative logic.

Command pulse mode	Timing
<p>Feed pulse and direction signal</p> <p>Maximum input frequency: Line driver: 500 kpps Open collector: 200 kpps</p>	<p style="text-align: center;">Forward rotation command Reverse rotation command</p> <p>Direction signals</p> <p>Feed pulses</p> <p style="text-align: right;"> Input filter: 200 kpps (Pn200.3 = 1) $t1 \leq 0.1 \mu s$ $t2 > 3.0 \mu s$ $\tau \geq 2.5 \mu s$ $T \geq 5.0 \mu s$ $(\tau/T) \times 100 \leq 50 (\%)$ </p> <p style="text-align: right;"> Input filter: 500 kpps (Pn200.3 = 0) $t1 \leq 0.1 \mu s$ $t2 > 3.0 \mu s$ $\tau \geq 1.0 \mu s$ $T \geq 2.0 \mu s$ $(\tau/T) \times 100 \leq 50 (\%)$ </p>
<p>Reverse pulse and forward pulse</p> <p>Maximum input frequency: Line driver: 500 kpps Open collector: 200 kpps</p>	<p style="text-align: center;">Forward rotation command Reverse rotation command</p> <p>Reverse pulses</p> <p>Forward pulses</p> <p style="text-align: right;"> Input filter: 200 kpps (Pn200.3 = 1) $t1 \leq 0.1 \mu s$ $t2 > 3.0 \mu s$ $\tau \geq 2.5 \mu s$ $T \geq 5.0 \mu s$ $(\tau/T) \times 100 \leq 50 (\%)$ </p> <p style="text-align: right;"> Input filter: 500 kpps (Pn200.3 = 0) $t1 \leq 0.1 \mu s$ $t2 > 3.0 \mu s$ $\tau \geq 1.0 \mu s$ $T \geq 2.0 \mu s$ $(\tau/T) \times 100 \leq 50 (\%)$ </p>
<p>90° phase difference signals</p> <p>Maximum input frequency: x1: Line driver: 500 kpps Open collector: 200 kpps x2: Line driver: 400 kpps Open collector: 200 kpps x4: Line driver: 200 kpps Open collector: 200 kpps</p>	<p style="text-align: center;">Forward rotation command Reverse rotation command</p> <p>Phase A pulses</p> <p>Phase B pulses</p> <p style="text-align: right;"> Input filter: 200 kpps (Pn200.3 = 1) $t1 \leq 0.1 \mu s$ $\tau \geq 2.5 \mu s$ $T \geq 5.0 \mu s$ $(\tau/T) \times 100 \leq 50 (\%)$ </p> <p style="text-align: right;"> Input filter: 500 kpps (Pn200.3 = 0) $t1 \leq 0.1 \mu s$ $\tau \geq 1.0 \mu s$ $T \geq 2.0 \mu s$ $(\tau/T) \times 100 \leq 50 (\%)$ </p>

- **+ Deviation Counter Reset (15: +ECRST)**
 – Deviation Counter Reset (14: –ECRST)

The content of the deviation counter will be reset when the deviation counter reset signal turns ON and the position loop will be disabled. Pn200.1 (position control setting 1: deviation counter reset) can be used to set either a status signal (high or low) or a differential signal (low to high or high to low). Input the reset signal for 20 μ s minimum. The counter will not be reset if the signal is too short.

- **Sensor ON Input (4: SEN)**
 Sensor ON Input Ground (2: SENGND)

SEN signal ON, OFF, and ON again.

When the SEN signal turns ON (low to high), the absolute encoder's multi-turn amount and the initial incremental pulses are sent. When the SEN signal is OFF, power cannot be supplied to the Servomotor even if a RUN command is input. The RUN command will not be enabled until the SEN signal turns ON and the encoder achieves normal operation. Do not turn ON the SEN signal for at least 3 s after turning on the power supply. Refer to the following diagram for turning the SEN signal ON, OFF, and ON again.

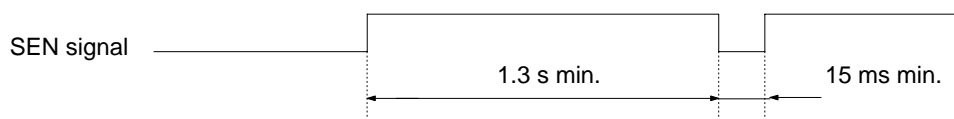

- **Backup Battery + Input (21: BAT)**
 Backup Battery – Input (22: BATGND)

These are the connection terminals for a backup battery for when power to the absolute encoder is interrupted. Normally a Backup Battery Unit is used and the battery is connected to CN8 (Battery Connector), so in that case do not connect anything to these terminals. The battery voltage is 2.8 to 4.5 V.

- **RUN Command Input (40: RUN)**

This is the input that turns ON the power drive circuit for the main circuit of the Servo Driver. If this signal is not input (i.e., servo-OFF status), the Servomotor cannot operate except for JOG operations.

Note This is the default allocation. Input terminal allocations (CN1 pins 40 to 46) can be changed by setting Pn50A.0 (input signal selection mode) to 1. The RUN signal is allocated by Pn50A.1.

- **Gain Reduction Input (41: MING)**

This signal is enabled for position control, speed control, and internally set control. When it is input, speed loop control is changed from PI to P control. Use it when it is necessary to weaken servo rigidity (repellant force with respect to external force). If position control is executed without including a position loop, there may be some position deviation due to temperature drift from a device such as the A/D converter. If a gain reduction is input in such a case, the loop gain of the speed loop will be lowered and the amount of drift will be decreased. If there is static friction torque on the load (5% or more of the rated torque), the Servomotor can be completely stopped.

If a position loop is included, when parts are inserted after positioning, the insertion operation is made easier because the repellant force with respect to external force is weakened by the inputting of this signal. This cannot be used for a vertical shaft where a gravity load is applied, or for applications where constant external force is applied, because position deviation will occur.

Note 1. This is the default allocation. Input terminal allocations (CN1 pins 40 to 46) can be changed by setting Pn50A.0 (input signal selection mode) to 1. The MING signal is allocated by Pn50A.2.

Note 2. With the default allocation, the function for pin 41 is changed to MING, PLOCK, TVSEL, RDIR, or IPG according to the Pn000.1 (control mode selection) setting and the control mode in operation. For details, refer to 4-4-3 Important Parameters.

● **Forward Drive Prohibit (42: POT)
Reverse Drive Prohibit (43: NOT)**

These two signals are the inputs for forward and reverse drive prohibit (overtravel). When they are input, driving is possible in the respective direction. When driving is prohibited, movement will stop according to the settings of Pn001.0 and Pn001.1. Refer to the diagram below.) Alarm status will not be generated at the Servo Driver while driving is prohibited

Note This is the default allocation. For either signal, the drive prohibition is normally disabled. This setting can be changed by Pn50A.3/Pn50b.0. Input terminal selections (CN1 pins 40 to 46) can be changed by means of Pn50A.0 (input signal selection mode).

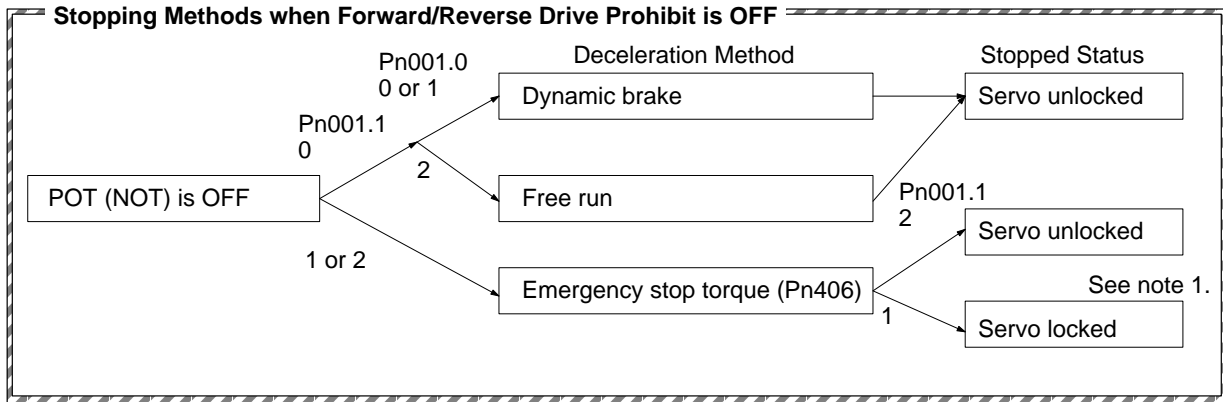

Note 1. The position loop will not operate for position control when stopping in this mode.

Note 2. When torque control is being used, the stopping method is determined by Pn001.0 setting. (The Pn001.1 setting is irrelevant.)

● **Alarm Reset (44: RESET)**

This is the external reset signal input for the servo alarm. Remove the cause of the alarm and then re-start operation.

Caution Turn OFF the RUN command before inputting the reset signal. It can be dangerous to input the reset signal while the RUN command is ON.

Note This is the default allocation. The input terminal allocations (CN1 pins 40 to 46) can be changed by setting Pn50A.0 (input signal selection mode) to 1. The RESET signal is allocated by Pn50b.1.

● **Forward Rotation Current Limit (45: PCL)
Reverse Rotation Current Limit (46: NCL)**

These two signals are inputs for limiting the forward and reverse output current (output torque).

When these signals are input, the output torque in the respective direction of rotation is limited by the settings of Pn404 (forward rotation external current limit) and Pn405 (reverse rotation external current limit).

When another torque limit function besides Pn404/Pn405 is enabled, the output torque is limited to the lower of the values.

Note 1. This is the default allocation. Input terminal allocations (CN1 pins 40 to 46) can be changed by setting Pn50A.0 (input signal selection mode) to 1. The PCL signal is allocated by Pn50b.2, and the NCL signal is allocated by Pn50b.3.

Note 2. With the default allocation, the functions for pins 45 and 46 can be changed to PCL/NCL or SPD1/SPD2 by means of the Pn000.1 (control mode selection) setting and the control mode in operation. For details, refer to *4-4-3 Important Parameters*.

● Rotation Direction Command Input (41: RDIR)

This signal specifies the direction of rotation when operation is carried out at the internally set speed (numbers 1 to 3). When this signal is OFF, the direction is forward; when it is ON, the direction is reverse.

Note 1. This is the default allocation. Input terminal allocations (CN1 pins 40 to 46) can be changed by setting Pn50A.0 (input signal selection mode) to 1. The RDIR signal is allocated by Pn50C.0.

Note 2. With the default allocation, the function for pin 41 is changed to MING, PLOCK, TVSEL, RDIR, or IPG according to the Pn000.1 (control mode selection) setting and the control mode in operation. For details, refer to *4-4-3 Important Parameters*.

● Speed Selection Command 1 (45: SPD1) Speed Selection Command 2 (46: SPD2)

Refer to the table under *Control Mode Switch (41: TVSEL)*.

Note 1. This is the default allocation. Input terminal allocations (CN1 pins 40 to 46) can be changed by setting Pn50A.0 (input signal selection mode) to 1. The SPD1 signal is allocated by Pn50C.1, and the SPD2 signal is allocated by Pn50C.2.

Note 2. The control mode will change according to the status of the TVSEL signal when Pn50A.0 is set to 1.

Note 3. With the default allocation, the functions for pin 45 and 46 can be changed to PCL/NCL or SPD1/SPD2 by means of the Pn000.1 (control mode selection) setting and the control mode in operation. For details, refer to *4-4-3 Important Parameters*.

● Control Mode Switch (41: TVSEL)

The SPD1 and SPD2 signals are enabled when Pn000.1 (function selection basic switch: control mode selection) is set to any of the settings between 3 and 6.

The TVSEL signal is enabled when Pn000.1 is set to any of the settings between 4 and 9.

The control mode and internal speed set in Pn301 to Pn303 are changed using signal combinations, as shown in the following table.

Control mode setting	TVSEL	SPD1: OFF		SPD1: ON	
		SPD2: OFF	SPD2: ON	SPD2: OFF	SPD2: ON
Pn000.1 = 3 Internally set speed control	---	Stop by speed loop.	No. 1 internal speed setting (Pn301)	No. 3 internal speed setting (Pn303)	No. 2 internal speed setting (Pn302)
Pn000.1 = 4 Internally set speed control ↔ Speed control	TVSEL: OFF	Stop by speed loop.	No. 1 internal speed setting (Pn301)	No. 3 internal speed setting (Pn303)	No. 2 internal speed setting (Pn302)
	Pn50A.0 = 0 (See note 2.)		Speed control		
	TVSEL: ON		Speed control		
Pn000.1 = 5 Internally set speed control ↔ Position control	TVSEL: OFF	Stop by speed loop.	No. 1 internal speed setting (Pn301)	No. 3 internal speed setting (Pn303)	No. 2 internal speed setting (Pn302)
	Pn50A.0 = 0 (See note 2.)		Position control		
	TVSEL: ON		Position control		
Pn000.1 = 6 Internally set speed control ↔ Torque control	TVSEL: OFF	Stop by speed loop.	No. 1 internal speed setting (Pn301)	No. 3 internal speed setting (Pn303)	No. 2 internal speed setting (Pn302)
	Pn50A.0 = 0 (See note 2.)		Torque control		
	TVSEL: ON		Torque control		
Pn000.1 = 7 Position control ↔ Speed control	TVSEL: OFF	Position control			
	TVSEL: ON	Speed control			
Pn000.1 = 8 Position control ↔ Torque control	TVSEL: OFF	Position control			
	TVSEL: ON	Torque control			
Pn000.1 = 9 Torque control ↔ Speed control	TVSEL: OFF	Torque control			
	TVSEL: ON	Speed control			

Note 1. This is the default allocation. Input terminal allocations (CN1 pins 40 to 46) can be changed by setting Pn50A.0 (input signal selection mode) to 1. The TVSEL signal is allocated by Pn50C.3.

Note 2. The allocation of the TVSEL signal and the control mode when there is no input will change when Pn50A is at the default setting (0) and Pn000.1 is set to 4, 5, or 6. (See above table.)

Note 3. With the default allocation, the function for pin 41 is changed to MING, PLOCK, TVSEL, RDIR, or IPG according to the Pn000.1 (control mode selection) setting and the control mode in operation. For details, refer to 4-4-3 Important Parameters.

● **Position Lock Command Input (41: PLOCK)**

If position control is executed without including a position loop, there may be some position deviation due to temperature drift from a device such as the A/D converter. If a position lock command is input in such a case, then, when the Servomotor rotation speed falls below the rotation speed set in Pn501 (position lock rotation speed), the speed control mode will be changed to position control mode and the Servomotor will be position-locked and completely stopped.

- Note 1.** This is the default allocation. Input terminal allocations (CN1 pins 40 to 46) can be changed by setting Pn50A.0 (input signal selection mode) to 1. The PLOCK signal is allocated by Pn50d.0.
- Note 2.** With the default allocation, the function for pin 41 is changed to MING, PLOCK, TVSEL, RDIR, or IPG according to the Pn000.1 (control mode selection) setting and the control mode in operation. For details, refer to 4-4-3 Important Parameters.

● **Pulse Disable Input (41: IPG)**

Command pulse inputs are disabled. The motor will stop when this signal goes ON, and the position will be locked.

- Note 1.** This is the default allocation. Input terminal allocations (CN1 pins 40 to 46) can be changed by setting Pn50A.0 (input signal selection mode) to 1. The IPG signal is allocated by Pn50d.1.
- Note 2.** With the default allocation, the function for pin 41 is changed to MING, PLOCK, TVSEL, RDIR, or IPG according to the Pn000.1 (control mode selection) setting and the control mode in operation. For details, refer to 4-4-3 Important Parameters.

● **Gain Switching Input (Not Allocated: GSEL)**

The GSEL signal changes the gain. When this signal is not input, the settings of Pn100 (speed loop gain), Pn101 (speed loop integration constant), and Pn102 (position loop gain) are used for control. When this signal is input, the settings of Pn104 (No. 2 speed loop gain), Pn105 (No. 2 speed loop integration constant), and Pn106 (No. 2 position loop gain) are used for control.

- Note** The GSEL signal is not allocated by default. Input terminal allocations (CN1 pins 40 to 46) can be changed by setting Pn50A.0 (input signal selection mode) to 1. The GSEL signal is allocated by Pn50d.2.

● **Command Pulse Factor Switching Input (Not Allocated: PSEL)**

The PSEL signal changes the command pulse factor.

When this signal is not input, the command pulse is used to rotate the motor.

When this signal is input, the result of applying the settings of Pn217 (command pulse factor) to the command pulse is used to rotate the motor. The PSON (command pulse factor enable) output, which indicates that the command pulse factor has changed, turns ON.

The ON/OFF timing for the PSEL signal and PSON signal is shown in the following diagram.

- Note 1.** When the command pulse factor change function is used, set Pn218.0 (command pulse factor switching function selection) to 1, and set the applicable factor in Pn217.

- Note 2.** Allocate the PSON signal using Pn510.2.

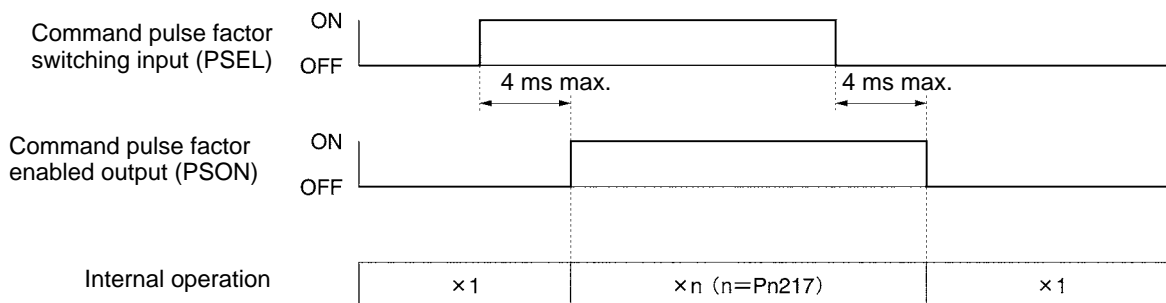

Note The PSEL signal is not allocated by default. Input terminal allocations (CN1 pins 40 to 46) can be changed by setting Pn50A.0 (input signal selection mode) to 1. The PSEL signal is allocated using Pn513.0.

■ **Control Output Details**

● **Control Output Sequence**

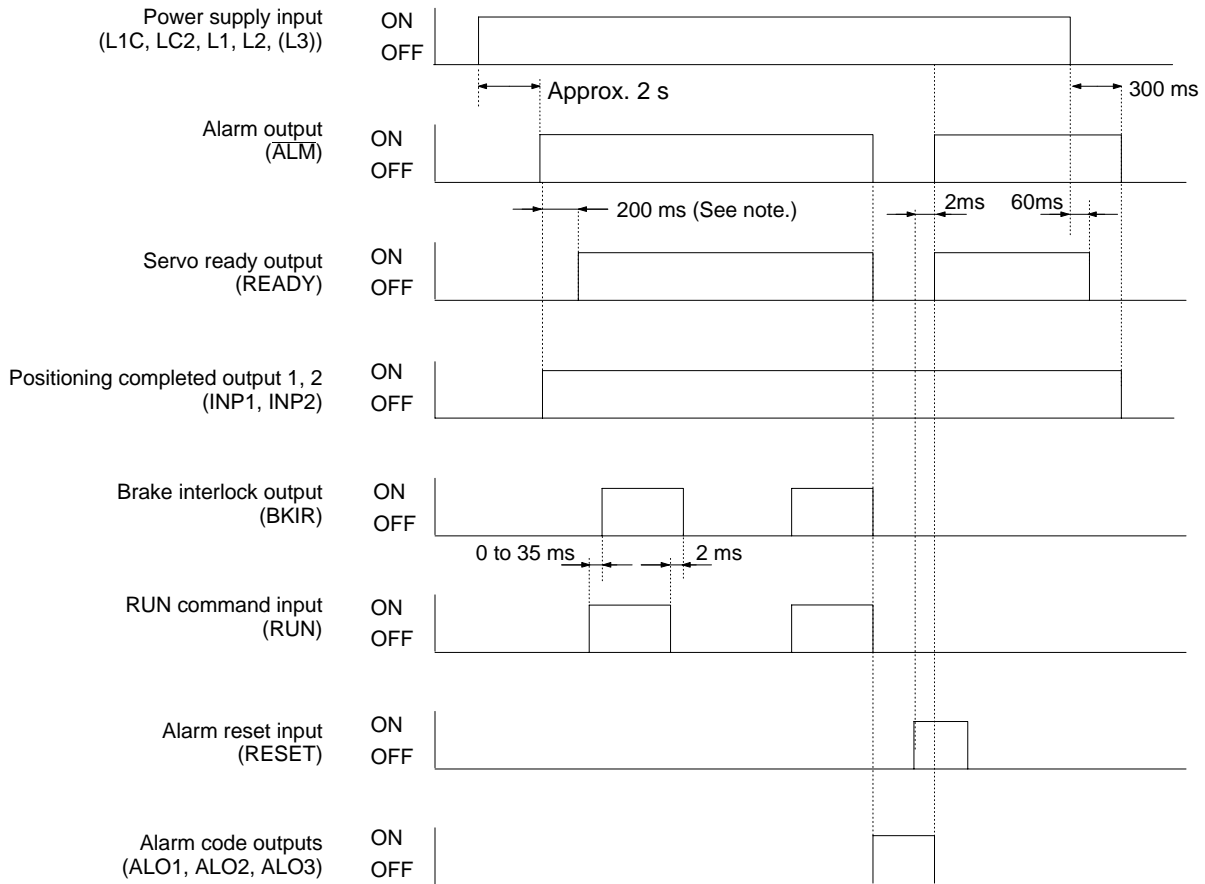

Note This signal will remain ON for approximately 250 ms after input of the SEN signal when using an absolute encoder.

● **Encoder A-, B-, Z-phase Outputs**

33: +A; 34: -A; 36: +B; 35: -B; 19: +Z; 20: -Z

● **48: +ABS, 49: -ABS**

Servomotor encoder signals are output as divided phase-difference pulses according to the encoder dividing rate setting (Pn201). The output form is line driver output, and conforms to EIA-RS-422A. Receive the signals with a line driver or high-speed photocoupler.

By inputting the SEN signal (low to high), absolute data is first output as serial data from the phase A, and then it is output as A-phase and B-phase initial incremental pulses (90° phase-difference pulses). The output operation is the same as for an ordinary incremental encoder (90° phase-difference pulses).

The following diagram shows the output phases. (The phases are the same for both absolute and incremental encoders.)

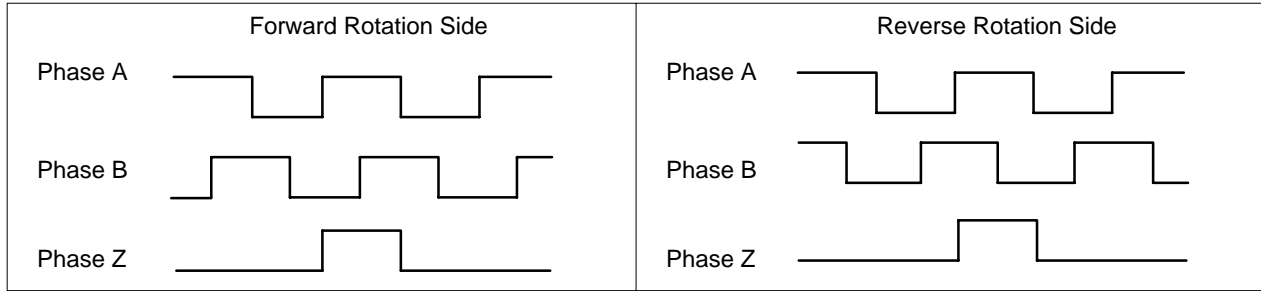

Note 1. Phase Z is synchronous with phase A.

Note 2. The speed of the initial incremental pulses depends on the Servo Driver software version. If the software version is “r0014,” the speed will be equivalent to approximately 2,500 r/min for 3,000-r/min motors and to approximately 1,000 r/min for 1,000-r/min motors. If the software version is “r0008,” the speed will be equivalent to approximately 2,500 r/min. (Same for all motors.)

● **Alarm Code Outputs 1 to 3 (37: ALO1; 38: AL02; 39: ALO3)**

When a Servo Driver error is detected, the contents of the error are output in 3-bit code. The alarm code output ground common is CN1 pin 1 (GND). For details, refer to 5-2 Alarms.

● **Alarm Output (31: $\overline{\text{ALM}}$)**
Alarm Output Ground (32: ALMCOM)

When the Servo Driver detects an error, outputs are turned OFF. At that time, an alarm code is output according to the contents of the error. This output is OFF at the time of powering up, and turns ON when the initial processing is completed.

● **Positioning Completed Output 1 (25: INP1)**
Positioning Completed Output 1 Common (26: INP1COM)
Positioning Completed Output 2 (Not Allocated: INP2)

The INP1 signal turns ON when the number of accumulated pulses in the deviation counter is less than Pn500 (positioning completed range 1). The INP2 signal turns ON when the number of pulses is less than Pn504 (positioning completed range 2). These signals are always OFF when the control mode is any mode other than the position control mode.

Note 1. These are the default allocations. The INP1 signal is allocated by Pn50E.0, and the INP2 signal is allocated by Pn510.0.

Note 2. With the default allocations, INP1 (enabled for position control) and VCMP (enabled for speed control) are allocated to CN1 pins 25 and 26.

● **Speed Conformity Output (25: VCMP)**
Speed Conformity Output Common (26: VCMPCOM)

The VCMP signal turns ON when the difference between the speed command and the Servomotor rotation speed is equal to or less than the value set for Pn503 (speed conformity signal output width). For example, if the speed command is for 3,000 r/min and the set value is for 50 r/min, it turns ON when the

rotation speed is between 2,950 and 3,050 r/min. This signal is always OFF when the control mode is any mode other than the speed control mode.

Note 1. These are the default allocations. The VCMP signal is allocated by Pn50E.1.

Note 2. With the default allocations, INP1 (enabled for position control) and VCMP (enabled for speed control) are allocated to CN1 pins 25 and 26.

● **Motor Rotation Detection Output (27: TGON)**

The TGON signal turns ON when the motor rotation speed exceeds the value set for Pn502 (rotation speed for motor rotation detection).

Note This is the default allocation. The TGON signal is allocated by Pn50E.2.

● **Servo Ready Output (29: READY) Servo Ready Output Common (30: READYCOM)**

The READY signal turns ON if no errors are detected after the main circuits are powered up.

The READY signal turns OFF when the absolute encoder is used and when the SEN signal is OFF.

Note This is the default allocation. The READY signal is allocated by Pn50E.3.

● **Current Limit Detection Output (Not Allocated: CLIMT)**

The CLIMT signal is turned ON in any of the following four cases:

- The output torque reaches the limit value set in Pn402 or Pn403 (the forward and reverse torque limits).
- The output torque reaches the limit value set in Pn404 or Pn405 (the forward and reverse rotation external current limits) while PCL/NCL (forward/reverse rotation current limit) is ON.
- The output torque reaches TREF (analog torque limit) when Pn002.0 (torque command input change) is set to 1.
- The output torque reaches TREF (analog torque limit), with PCL/NCL (forward/reverse rotation current limit) ON, when Pn002.0 (torque command input change) is set to 3.

Note The CLIMT signal is not allocated by default. It is allocated by Pn50F.0.

● **Speed Limit Detection Output (Not Allocated: VLIMIT)**

The VLIMIT signal is turned ON in either of the following two cases:

- The Servomotor rotation speed reaches the limit set in Pn407 (speed limit).
- The Servomotor rotation speed reaches REF (analog speed limit) when Pn002.1 (speed command input change) is set to 1.

This signal is always OFF when the control mode is any mode other than the torque control mode.

Note The VLIMIT signal is not allocated by default. It is allocated by Pn50F.1.

● Brake Interlock Output (Not Allocated: BKIR)

External brake timing signals are output according to the settings in Pn506 (brake timing 1), Pn507 (brake command speed), and Pn508 (brake timing 2).

Note 1. The BKIR signal is not allocated by default. It is allocated by Pn50F.2.

Note 2. For details on the brake interlock function, refer to *4-5-8 Brake Interlock (All Operating Modes)*.

● Warning Output (Not Allocated: WARN)

The WARN signal is turned ON in any of the following three cases:

- The Servomotor output torque (effective value) exceeds 115% of the rated torque.
- The regenerative energy exceeds the tolerance of the internal regeneration resistance.
- When external regeneration resistance is used, the regenerative energy exceeds the value set for Pn600 (regeneration resistor capacity).

Note The $\overline{\text{WARN}}$ signal is not allocated by default. It is allocated by Pn50F.3.

● Command Pulse Factor Enabled Output (Not Allocated: PSON)

The PSON signal turns ON when the command pulse factor has changed after the PSEL (command pulse factor switching) input has been turned ON. After the PSEL input is turned OFF, PSON turns OFF when the command pulse factor returns to 1.

Note 1. Refer to the information on the PSEL signal for details on timing for switching the command pulse factor.

Note 2. When command pulse factor switching is used, set Pn218.0 (command pulse factor switching function selection) to 1, and set the applicable factor in Pn217.

Note 3. Allocate the PSEL signal using Pn513.0.

Note 4. The PSON signal is not allocated by default. The PSON signal is allocated using Pn510.2.

2-4-5 Encoder Input Specifications (CN2)

Pin No.	Symbol	Signal name	Function/Interface
1	E5V	Encoder power supply +5 V	Power supply outlet for encoder: 5 V, 180 mA Note An automatic reset fuse is provided to protect output. If the fuse is activated due to overcurrent, it will automatically reset after a fixed period of time has lapsed without current flowing (supported by Servo Drivers with software version "r.0037" or later).
2	E0V	Encoder power supply GND	
3	BAT+	Battery + [absolute]	Backup power output for encoder (3.6 V, 20 μ A for backup or when stopped; 3 μ A when Servo Driver is being powered)
4	BAT-	Battery - [absolute]	
5	S+	Encoder + phase-S input	Line driver input (conforming to EIA-RS422A) (Input impedance: 120 Ω)
6	S-	Encoder - phase-S input	
Shell	FG	Shielded ground	Cable shielded ground

● **CN2 Connectors Used (6P)**

Receptacle at Servo Driver 53460-0611 (Molex Japan Co., Ltd.)
 Cable plug 55100-0670 (Molex Japan Co., Ltd.)

2-4-6 Parameter Unit Input Specifications (CN3)

Pin No.	Symbol	Signal name	Function/Interface
1, 8	TXD+	Transmission data +	This is data transmitted to a Parameter Unit (or a personal computer). Line receiver input
2, 9	TXD-	Transmission data -	
3, 10	RXD+	Reception data +	This is data received from a Parameter Unit (or a personal computer). Line receiver input
4, 6	RXD-	Reception data -	
5	PRMU	Unit switching	This is the switching terminal for a Parameter Unit or personal computer.
7	RT	Termination resistance terminal	This is the termination resistance terminal for the line receiver. 6-pin connection for RS-422 communications (final Servo Driver only).
11, 12	-	(Not used.)	(Do not connect.)
13	+5V	+5 V output	This is the +5-V power supply output to the Parameter Unit.
14	GND	Ground	
Shell	FG	Shielded ground	Cable shielded ground

● **CN3 Connectors Used (14P)**

Receptacle at Servo Driver 10214-52AJL (Sumitomo 3M)
 Cable plug with solder 10114-3000VE (Sumitomo 3M)
 Cable case 10314-50A0-008 (Sumitomo 3M)

2-4-7 Monitor Output Connector Specifications (CN5)

Pin No.	Symbol	Signal name	Function/Interface
1	MM	Analog Monitor 2	Default setting: Speed monitor, 1 V per 1,000 r/min (Can be changed by Pn003.1.)
2	AM	Analog Monitor 1	Default setting: Current monitor, 1 V / rated torque (Can be changed by Pn003.0.)
3	GND	Analog Monitor Ground	Grounds for analog monitors 1 and 2
4	GND	Analog Monitor Ground	

● **CN5 Connectors Used (4P)**

Pin header at Servo Driver DF11-4DP-2DS (Hirose Electric)
 Cable connector socket DF11-4DS-2C (Hirose Electric)
 Cable connector contact DF11-2428SCF (Hirose Electric)

● **Monitored Items and Scaling Changes**

Monitored items can be changed by means of Pn003 (function selection application switch 3). It is also possible to change the scaling and adjust the output voltage offset in the system check mode.

Monitored item	Monitor output specifications	Pn003.0, Pn003.1 setting
Servomotor rotation speed (speed monitor)	1 V per 1,000 r/min; forward rotation: – voltage; reverse rotation: + voltage	0
	1 V per 250 r/min; forward rotation: – voltage; reverse rotation: + voltage	6
	1 V per 125 r/min; forward rotation: – voltage; reverse rotation: + voltage	7
Torque command (current monitor)	1 V / rated torque; forward acceleration: – voltage; reverse acceleration: + voltage	2
Speed command	1 V per 1,000 r/min; forward command: – voltage; reverse command: + voltage	1
Position error	0.05 V / 1 command unit; plus error: – voltage; reverse error: + voltage	3
	0.05 V / 100 command units; plus error: – voltage; minus error: + voltage	4
Command pulse frequency	1 V per 1,000 r/min; forward rotation command: – voltage; reverse rotation command: + voltage	5

Note 1. The table shows the specifications with no offset adjustment or scaling changes.

Note 2. The maximum output voltage is ± 8 V. Normal outputs will not be possible if this value is exceeded.

Note 3. The output accuracy is approximately $\pm 15\%$.

2-4-8 Battery Connector Specifications (CN8)

Pin No.	Signal name	Name	Function/Interface
1	BAT	Backup battery, + input	Backup power supply input for absolute encoder; 3.6 V, 20 μ A for backup or when stopped; 3 μ A when Servo Driver is being powered.
2	BATGND	Backup battery, – input	

• CN8 Connectors Used (2P)

Pin header at Servo Driver	DF3-2DP-2DS	(Hirose Electric)
Cable connector socket	DF3-2S-2C	(Hirose Electric)
Cable connector contact	DF3-2428SCFC	(Hirose Electric)

2-5 Servomotor Specifications

■ OMNUC W-series AC Servomotors (R88M-W□)

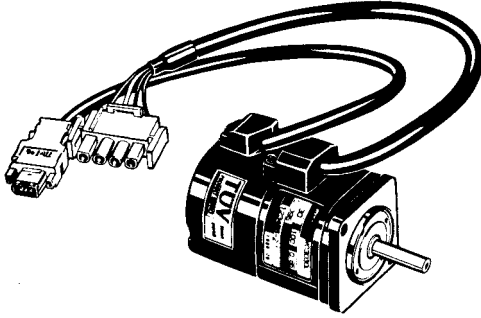

There are three kinds of OMNUC W-Series AC Servomotors, as follows:

- 3,000-r/min Servomotors
- 3,000-r/min Flat-style Servomotors
- 1,000-r/min Servomotors
- 1,500-r/min Servomotors

These Servomotors also have optional specifications, such as shaft type, with or without brake, waterproofing, with or without reduction gears, and so on. Select the appropriate Servomotor for your system according to the load conditions and installation environment.

2-5-1 General Specifications

Item	3,000-r/min Servomotors		3,000-r/min Flat-style Servomotors	1,000-r/min Servomotors 1,500-r/min Servomotors
	30 to 750 W	1 to 5 kW		
Ambient operating temperature	0 to 40°C			
Ambient operating humidity	20% to 80% (with no condensation)			
Storage ambient temperature	-20 to 60°C			
Ambient storage temperature	20% to 80% (with no condensation)			
Storage and operating atmosphere	No corrosive gasses.			
Vibration resistance (See note 1.)	10 to 2,500 Hz in X, Y, and Z directions with acceleration 49 m/s ² max.	10 to 2,500 Hz in X, Y, and Z directions with acceleration 24.5 m/s ² max.	10 to 2,500 Hz in X, Y, and Z directions with acceleration 49 m/s ² max.	10 to 2,500 Hz in X, Y, and Z directions with acceleration 24.5 m/s ² max.
Impact resistance	Acceleration 490 m/s ² max., in X, Y, and Z directions, two times	Acceleration 490 m/s ² max., in X, Y, and Z directions, two times	Acceleration 490 m/s ² max., in X, Y, and Z directions, two times	Acceleration 490 m/s ² max., in X, Y, and Z directions, two times
Insulation resistance	Between power line terminals and FG: 10 MΩ min. (500 V DC megger)			
Dielectric strength	Between power line terminals and FG: 1,500 V AC for 1 min at 50/60 Hz			
Run position	All directions			
Insulation grade	Type B	Type F	Type B	Type F
Structure	Totally-enclosed self-cooling			
Vibration grade	V-15			
Mounting method	Flange-mounting			
EC Directives	EMC Directive	EN55011 Class A Group1 EN61000-6-2		
	Low-voltage Directive	IEC60034-8, EN60034-1, -5, -9		
UL standards	UL1004			
cUL standards	cUL C22.2 No. 100			

Note 1. Vibration may be amplified due to sympathetic resonance of machinery, so use the Servomotor Driver under conditions which will not exceed 80% of the specification values over a long period of time.

Note 2. Water-proof connectors must be used on the Power and Encoder Cables when used in environments subject to direct contact with water. Refer to 3-1-2 *Servomotors* for the recommended connectors.

Note 3. The above items reflect individual evaluation testing. The results may differ under compound conditions.

Note 4. The Servomotors cannot be used in misty environments.

● Degree of Protection

The degree of protection of Servomotors depends on the motor type as shown in the following tables. Servomotors include ordinary models and oil-seal models. Oil seals are provided to prevent oil or grease from entering into through-shaft portion. They are not designed to prevent water permeation.

3,000 r/min Servomotors

	30 to 750 W	1 to 5 kW
Ordinary type	IP55 (Excluding through-shaft portion)	IP67 (Excluding through-shaft portion) (See note.)
Oil-seal type	IP55 (Excluding through-shaft portion)	IP67 (Excluding through-shaft portion) (See note.)

3,000 r/min Flat-style Servomotors

Ordinary type	IP55 (Excluding through-shaft portion)
Oil-seal type	IP55 (Excluding through-shaft portion)
Waterproof type	IP67 (Excluding through-shaft portion)

1,500 r/min Servomotors and 1,500 r/min Servomotors

Ordinary type	IP67 (Excluding through-shaft portion) (See note.)
Oil-seal type	IP67 (Excluding through-shaft portion) (See note.)

Note Oil seals can be attached or removed by the user.

2-5-2 Performance Specifications

■ 3,000-r/min Servomotors

● Performance Specifications Table

Item	Unit	100 V AC				200 V AC				
		R88M -W03030L	R88M -W05030L	R88M -W10030L	R88M -W20030L	R88M -W03030H	R88M -W05030H	R88M -W10030H	R88M -W20030H	
		R88M -W03030S	R88M -W05030S	R88M -W10030S	R88M -W20030S	R88M -W03030T	R88M -W05030T	R88M -W10030T	R88M -W20030T	
Rated output*	W	30	50	100	200	30	50	100	200	
Rated torque*	N•m	0.0955	0.159	0.318	0.637	0.0955	0.159	0.318	0.637	
Rated rotation speed	r/min	3,000				3,000				
Momentary maximum rotation speed	r/min	5,000				5,000				
Momentary maximum torque*	N•m	0.286	0.477	0.955	1.91	0.286	0.477	0.955	1.91	
Rated current*	A (rms)	0.66	0.95	2.4	3.0	0.44	0.64	0.91	2.1	
Momentary maximum current*	A (rms)	2.0	2.9	7.2	9.0	1.3	2.0	2.8	6.5	
Rotor inertia	kg•m ² (GD ² /4)	1.66 × 10 ⁻⁶	2.20 × 10 ⁻⁶	3.64 × 10 ⁻⁶	1.06 × 10 ⁻⁵	1.66 × 10 ⁻⁶	2.20 × 10 ⁻⁶	3.64 × 10 ⁻⁶	1.06 × 10 ⁻⁵	
Torque constant*	N•m/A	0.157	0.182	0.146	0.234	0.238	0.268	0.378	0.327	
Power rate*	kW/s	5.49	11.5	27.8	38.2	5.49	11.5	27.8	38.2	
Mechanical time constant	ms	1.4	0.85	0.61	0.41	1.4	0.88	0.53	0.39	
Electrical time constant	ms	1.0	1.1	1.1	4.4	1.0	1.1	1.2	4.6	
Allowable radial load	N	68	68	78	245	68	68	78	245	
Allowable thrust load	N	54	54	54	74	54	54	54	74	
Weight	Without brake	kg	Approx. 0.3	Approx. 0.4	Approx. 0.5	Approx. 1.1	Approx. 0.3	Approx. 0.4	Approx. 0.5	Approx. 1.1
	With brake	kg	Approx. 0.6	Approx. 0.7	Approx. 0.8	Approx. 1.6	Approx. 0.6	Approx. 0.7	Approx. 0.8	Approx. 1.6
Radiation shield dimensions (material)		t6 × □250 mm (Al)				t6 × □250 mm (Al)				
Applicable load inertia		See note 6.				See note 6.				
Applicable Servo Driver (R88D-)		WTA3HL	WTA5HL	WT01HL	WT02HL	WTA3H	WTA5H	WT01H	WT02H	

Item	Unit	100 V AC				200 V AC				
		R88M -W03030L	R88M -W05030L	R88M -W10030L	R88M -W20030L	R88M -W03030H	R88M -W05030H	R88M -W10030H	R88M -W20030H	
		R88M -W03030S	R88M -W05030S	R88M -W10030S	R88M -W20030S	R88M -W03030T	R88M -W05030T	R88M -W10030T	R88M -W20030T	
Brake specifications	Brake inertia	kg·m ² (GD ² /4)	8.5 × 10 ⁻⁷	8.5 × 10 ⁻⁷	8.5 × 10 ⁻⁷	5.8 × 10 ⁻⁶	8.5 × 10 ⁻⁷	8.5 × 10 ⁻⁷	8.5 × 10 ⁻⁷	5.8 × 10 ⁻⁶
	Excitation voltage	V	24 V DC ±10%				24 V DC ±10%			
	Power consumption (at 20°C)	W	6	6	6	6.9	6	6	6	6.9
	Current consumption (at 20°C)	A	0.25	0.25	0.25	0.29	0.25	0.25	0.25	0.29
	Static friction torque	N·m	0.2 min.	0.2 min.	0.34 min.	1.47 min.	0.2 min.	0.2 min.	0.34 min.	1.47 min.
	Attraction time (See note 3.)	ms	30 max.	30 max.	30 max.	60 max.	30 max.	30 max.	30 max.	60 max.
	Release time (See note 3.)	ms	60 max.	60 max.	60 max.	20 max.	60 max.	60 max.	60 max.	20 max.
	Backlash		1° (reference value)				1° (reference value)			
	Rating	–	Continuous				Continuous			
	Insulation grade	–	Type F				Type F			

Note 1. *The values for items marked by asterisks are the values at an armature winding temperature of 100°C (for models of 750 W or less) or 20°C (for models of 1 kW or more), combined with the Servo Driver. Other values are at normal conditions (20°C, 65%). The momentary maximum torque shown above indicates the standard value.

Note 2. The brakes are the non-excitation operation type (released when excitation voltage is applied).

Note 3. The operation time is the measured value (reference value) with a surge killer (CR50500, by Okaya Electric Industries co. LTD) inserted.

Note 4. The allowable radial and thrust loads are the values determined for a service life of 20,000 hours at normal operating temperatures.

Note 5. The value indicated for the allowable radial load is for the positions shown in the diagrams following the next table.

Note 6. Applicable Load Inertia

- 1) The drivable load inertia ratio (load inertia/rotor inertia) changes depending on the mechanical configuration being driven and its rigidity. Highly rigid machines can operate with a large load inertia. Select a Servomotor and verify operation.
- 2) If the dynamic brake is used frequently with a large load inertia, it may lead to burnout of the dynamic brake resistor. Do not repeatedly turn the Servo ON and OFF with the dynamic brake enabled.

Item	Unit	200 V AC								
		R88M -W40030H	R88M -W75030H	R88M -W1K030H	R88M -W1K530H	R88M -W2K030H	R88M -W3K030H	R88M -W4K030H	R88M -W5K030H	
		R88M -W40030T	R88M -W75030T	R88M -W1K030T	R88M -W1K530T	R88M -W2K030T	R88M -W3K030T	R88M -W4K030T	R88M -W5K030T	
Rated output*	W	400	750	1,000	1,500	2,000	3,000	4,000	5,000	
Rated torque*	N•m	1.27	2.39	3.18	4.9	6.36	9.8	12.6	15.8	
Rated rotation speed	r/min	3,000								
Momentary maximum rotation speed	r/min	5,000								
Momentary maximum torque*	N•m	3.82	7.16	9.54	14.7	19.1	29.4	37.8	47.6	
Rated current*	A (rms)	2.8	4.4	5.7	9.7	12.7	18.8	25.4	28.6	
Momentary maximum current*	A (rms)	8.5	13.4	17	28	42	56	77	84	
Rotor inertia	kg•m ² (GD ² /4)	1.73 × 10 ⁻⁵	6.72 × 10 ⁻⁵	1.74 × 10 ⁻⁴	2.47 × 10 ⁻⁴	3.19 × 10 ⁻⁴	7.00 × 10 ⁻⁴	9.60 × 10 ⁻⁴	1.23 × 10 ⁻³	
Torque constant*	N•m/A	0.498	0.590	0.64	0.56	0.54	0.57	0.53	0.60	
Power rate*	kW/s	93.7	84.8	57.9	97.2	127	137	166	202	
Mechanical time constant	ms	0.25	0.26	0.87	0.74	0.62	0.74	0.65	0.59	
Electrical time constant	ms	5.4	8.7	7.1	7.7	8.3	13.0	14.1	14.7	
Allowable radial load	N	245	392	686	686	686	980	1,176	1,176	
Allowable thrust load	N	74	147	196	196	196	392	392	392	
Weight	With-out brake	kg	Approx. 1.7	Approx. 3.4	Approx. 4.6	Approx. 5.8	Approx. 7.0	Approx. 11.0	Approx. 14.0	Approx. 17.0
	With brake	kg	Approx. 2.2	Approx. 4.3	Approx. 6.0	Approx. 7.5	Approx. 8.5	Approx. 14.0	Approx. 17.0	Approx. 20.0
Radiation shield dimensions (material)		t6 × □250 mm (Al)		t12 × □300 mm (Al)			t12 × □400 mm (Al)			
Applicable load inertia		See note 6.								
Applicable Servo Driver (R88D-)		WT04H	WT08H	WT10H	WT15H	WT20H	WT30H	WT50H	WT50H	

Item	Unit	200 V AC									
		R88 -W40030H	R88M -W75030H	R88M -W1K030H	R88M -W1K530H	R88M -W2K030H	R88M -W3K030H	R88M -W4K030H	R88M -W5K030H		
		R88M -W40030T	R88M -W75030T	R88M -W1K030T	R88M -W1K530T	R88M -W2K030T	R88M -W3K030T	R88M -W4K030T	R88M -W5K030T		
Brake specifications	Brake inertia	kg·m ² (GD ² /4)	5.8 × 10 ⁻⁶	1.4 × 10 ⁻⁵	3.25 × 10 ⁻⁵	3.25 × 10 ⁻⁵	3.25 × 10 ⁻⁵	2.1 × 10 ⁻⁴	2.1 × 10 ⁻⁴	2.1 × 10 ⁻⁴	
	Excitation voltage	V	24 V DC ±10%								
	Power consumption (at 20°C)	W	6.9	7.7	7	7	7	9.85	9.85	9.85	
	Current consumption (at 20°C)	A	0.29	0.32	0.29	0.29	0.29	0.41	0.41	0.41	
	Static friction torque	N·m	1.47 min.	2.45 min.	7.84 min.	7.84 min.	7.84 min.	20 min.	20 min.	20 min.	
	Attraction time (See note 3.)	ms	60 max.	80 max.	180 max.	180 max.	180 max.	180 max.	180 max.	180 max.	
	Release time (See note 3.)	ms	20 max.	20 max.	100 max.	100 max.	100 max.	100 max.	100 max.	100 max.	
	Backlash		1° (reference value)								
	Rating	–	Continuous								
	Insulation grade	–	Type F								

Note 1. *The values for items marked by asterisks are the values at an armature winding temperature of 100°C (for models of 750 W or less) or 20°C (for models of 1 kW or more), combined with the Servo Driver. Other values are at normal conditions (20°C, 65%). The momentary maximum torque shown above indicates the standard value.

Note 2. The brakes are the non-excitation operation type (released when excitation voltage is applied).

Note 3. The operation time is the measured value (reference value) with a surge killer (CR50500, by Okaya Electric Industries co. LTD) inserted.

Note 4. The allowable radial and thrust loads are the values determined for a service life of 20,000 hours at normal operating temperatures.

Note 5. The value indicated for the allowable radial load is for the positions shown in the following diagrams.

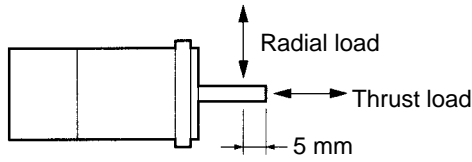

(Models of 750 W or less)

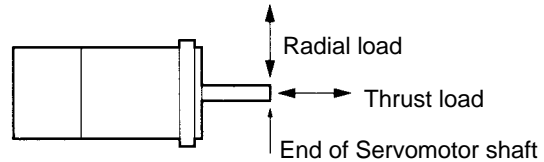

(Models of 1 kW or more)

Note 6. The applicable load inertia is restricted by the regenerative energy absorption capacity.

• Torque and Rotation Speed Characteristics

3,000-r/min Servomotors (100 V AC)

The following graphs show the characteristics with a 3-m standard cable and 100-V AC input.

R88M-W03030L/S (30 W)

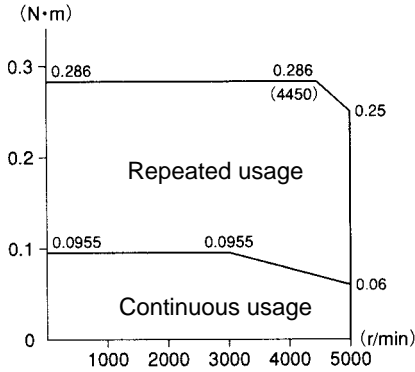

R88M-W05030L/S (50 W)

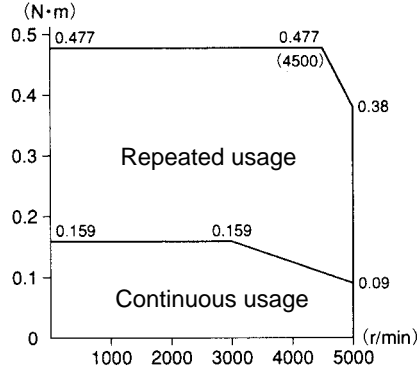

R88M-W10030L/S (100 W)

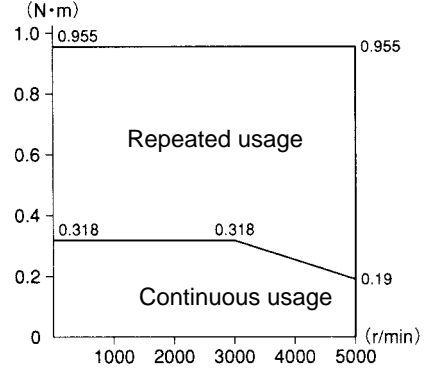

R88M-W20030L/S (200 W)

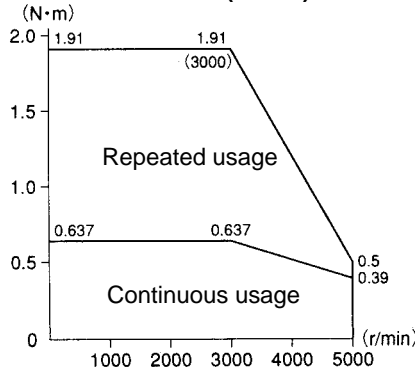

3,000-r/min Servomotors (200 V AC)

The following graphs show the characteristics with a 3-m standard cable and 200-V AC input.

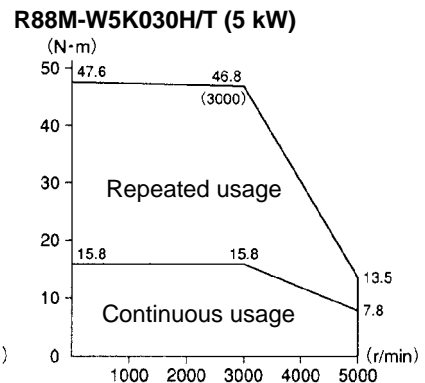
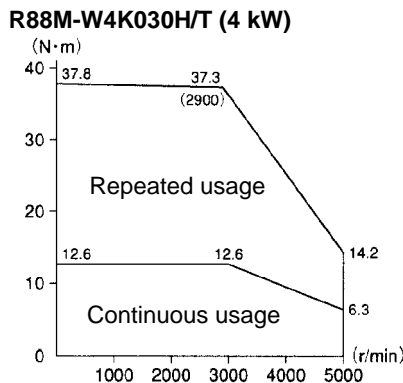
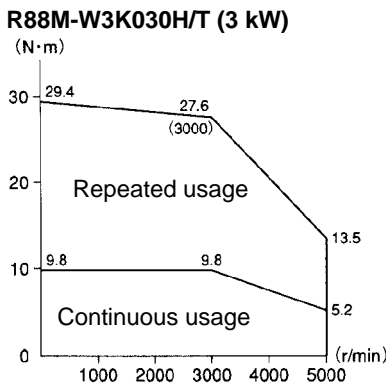
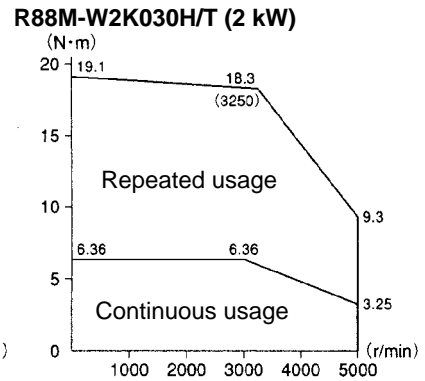
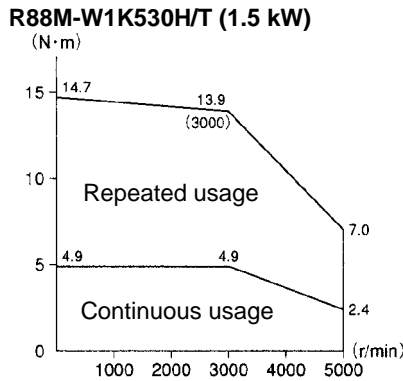
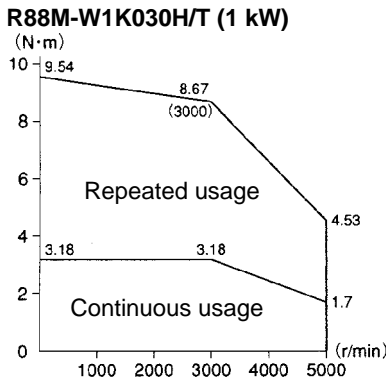
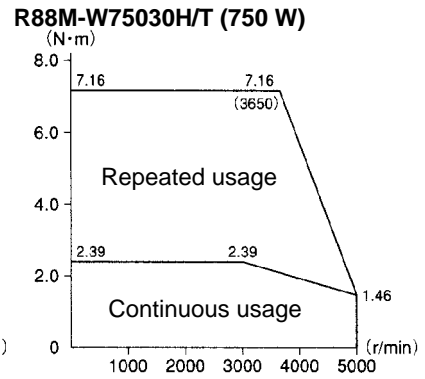
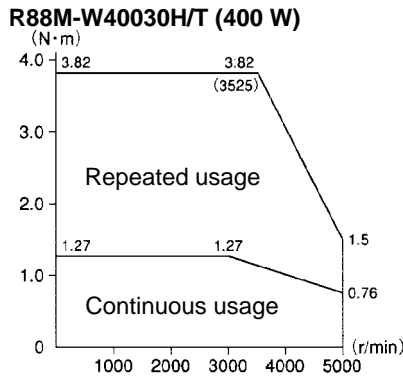
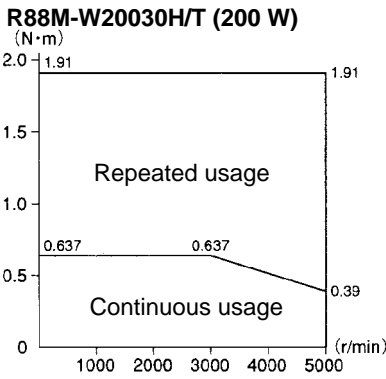
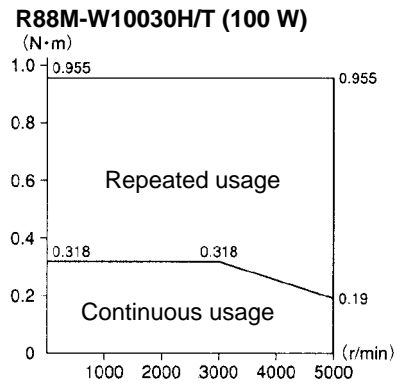
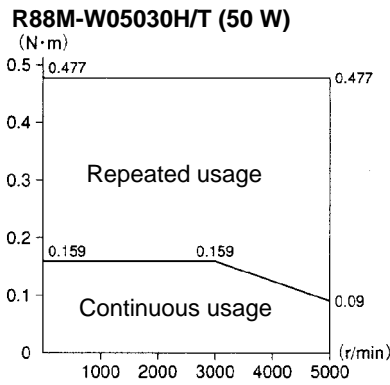
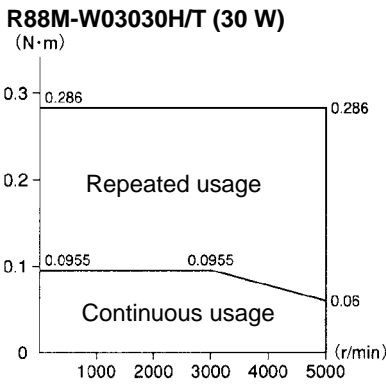

● **Servomotor and Mechanical System Temperature Characteristics**

- W-series AC Servomotors use rare earth magnets (neodymium-iron magnets). The temperature coefficient for these magnets is approximately $-0.13\%/^{\circ}\text{C}$. As the temperature drops, the Servomotor’s momentary maximum torque increases, and as the temperature rises the Servomotor’s momentary maximum torque decreases. When the normal temperature of 20°C and -10°C are compared, the momentary maximum torque increases by approximately 4%. Conversely, when the magnet warms up to 80°C from the normal temperature of 20°C , the momentary maximum torque decreases by approximately 8%.
- Generally, in a mechanical system, when the temperature drops the friction torque increases and the load torque becomes larger. For that reason, overloading may occur at low temperatures. In particular, in systems which use deceleration devices, the load torque at low temperatures may be nearly twice the load torque at normal temperatures. Check with a current monitor to see whether overloading is occurring at low temperatures, and how much the load torque is. Likewise, check to see whether there abnormal Servomotor overheating or alarms are occurring at high temperatures.
- An increase in load friction torque visibly increases load inertia. Therefore, even if the Servo Driver parameters are adjusted at a normal temperature, there may not be optimal operation at low temperatures. Check to see whether there is optimal operation at low temperatures too.

Caution Do not use 2-kW or 5-kW Servomotors within the shaded portions of the following diagrams. If used in these regions, the Servomotor may heat, causing the encoder to malfunction.

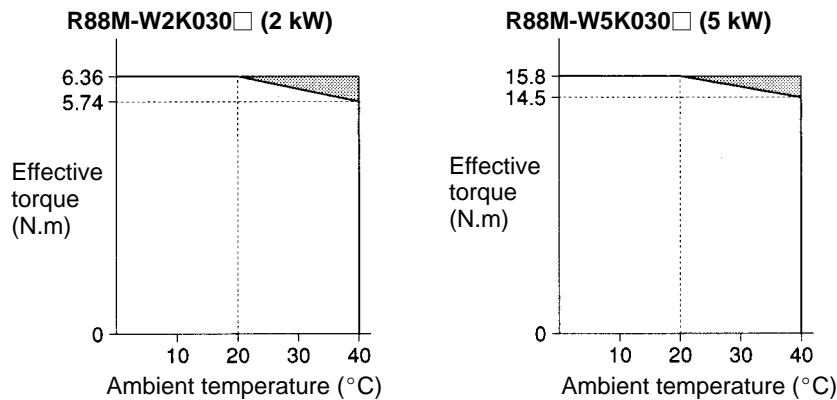

■ 3,000-r/min Flat-style Servomotors

● Performance Specifications Table

Item	Unit	100 V AC		200 V AC					
		R88M -WP10030 L	R88M -WP20030 L	R88M -WP10030 H	R88M -WP20030 H	R88M -WP40030 H	R88M -WP75030 H	R88M -WP1K530 H	
		R88M -WP10030 S	R88M -WP20030 S	R88M -WP10030 T	R88M -WP20030 T	R88M -WP40030 T	R88M -WP75030 T	R88M -WP1K530 T	
Rated output*	W	100	200	100	200	400	750	1,500	
Rated torque*	N•m	0.318	0.637	0.318	0.637	1.27	2.39	4.77	
Rated rotation speed	r/min	3,000		3,000					
Momentary maximum rotation speed	r/min	5,000		5,000					
Momentary maximum torque*	N•m	0.955	1.91	0.955	1.91	3.82	7.16	14.3	
Rated current*	A (rms)	2.2	2.7	0.89	2.0	2.6	4.1	7.5	
Momentary maximum current*	A (rms)	7.1	8.4	2.8	6.0	8.0	13.9	23.0	
Rotor inertia	kg•m ² (GD ² /4)	4.91 × 10 ⁻⁶	1.93 × 10 ⁻⁵	4.91 × 10 ⁻⁶	1.93 × 10 ⁻⁵	3.31 × 10 ⁻⁵	2.10 × 10 ⁻⁵	4.02 × 10 ⁻⁴	
Torque constant*	N•m/A	0.160	0.258	0.392	0.349	0.535	0.641	0.687	
Power rate*	kW/s	20.6	21.0	20.6	21.0	49.0	27.1	56.7	
Mechanical time constant	ms	0.56	0.64	0.53	0.54	0.36	0.66	0.46	
Electrical time constant	ms	3.6	6.3	3.7	7.4	8.6	18	22	
Allowable radial load	N	78	245	78	245	245	392	490	
Allowable thrust load	N	49	68	49	68	68	147	147	
Weight	Without brake	kg	Approx. 0.7	Approx. 1.4	Approx. 0.7	Approx. 1.4	Approx. 2.1	Approx. 4.2	Approx. 6.6
	With brake	kg	Approx. 0.9	Approx. 1.9	Approx. 0.9	Approx. 1.9	Approx. 2.6	Approx. 5.7	Approx. 8.1
Radiation shield dimensions (material)		t6 × □250 mm (Al)		t6 × □250 mm (Al)			t12 × □300 mm (Al)		
Applicable load inertia		See note 6.							
Applicable Servo Driver (R88D-)		WT01HL	WT02HL	WT01H	WT02H	WT04H	WT08H	WT15H	

Item	Unit	100 V AC		200 V AC					
		R88M -WP10030 L	R88M -WP20030 L	R88M -WP10030 H	R88M -WP20030 H	R88M -WP40030 H	R88M -WP75030 H	R88M -WP1K530 H	
		R88M -WP10030 S	R88M -WP20030 S	R88M -WP10030 T	R88M -WP20030 T	R88M -WP40030 T	R88M -WP75030 T	R88M -WP1K530 T	
Brake specifications	Brake inertia	kg·m ² (GD ² /4)	2.9 × 10 ⁻⁶	1.09 × 10 ⁻⁵	2.9 × 10 ⁻⁶	1.09 × 10 ⁻⁵	1.09 × 10 ⁻⁵	8.75 × 10 ⁻⁵	8.75 × 10 ⁻⁵
	Excitation voltage	V	24 V DC ±10%		24 V DC ±10%				
	Power consumption (at 20°C)	W	8.1	7.6	8.1	7.6	7.6	7.5	10
	Current consumption (at 20°C)	A	0.34	0.29	0.34	0.29	0.34	0.31	0.42
	Static friction torque	N·m	0.48 to 0.73	0.95 to 1.42	0.48 to 0.73	0.95 to 1.42	1.96 to 2.84	3.5 min.	7.1 min.
	Attraction time (See note 3.)	ms	20 max.	20 max.	20 max.	20 max.	60 max.	20 max.	20 max.
	Release time (See note 3.)	ms	40 max.	40 max.	40 max.	40 max.	20 max.	40 max.	40 max.
	Backlash		1° (reference value)		1° (reference value)				
	Rating	–	Continuous		Continuous				
Insulation grade	–	Type F		Type F					

Note 1. The values for items marked by asterisks are the values at an armature winding temperature of 100°C, combined with the Servo Driver. Other values are at normal conditions (20°C, 65%). The momentary maximum torque shown above indicates the standard value.

Note 2. The brakes are the non-excitation operation type (released when excitation voltage is applied).

Note 3. The operation time is the measured value (reference value) with a surge killer (CR50500, by Okaya Electric Industries co. LTD) inserted.

Note 4. The allowable radial and thrust loads are the values determined for a service life of 20,000 hours at normal operating temperatures.

Note 5. The value indicated for the allowable radial load is for the position shown in the following diagram.

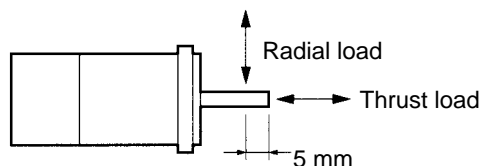

Note 6. Applicable Load Inertia

- 1) The drivable load inertia ratio (load inertia/rotor inertia) changes depending on the mechanical configuration being driven and its rigidity. Highly rigid machines can operate with a large load inertia. Select a Servomotor and verify operation.
- 2) If the dynamic brake is used frequently with a large load inertia, it may lead to burnout of the dynamic brake resistor. Do not repeatedly turn the Servo ON and OFF with the dynamic brake enabled.

• Torque and Rotation Speed Characteristics

3,000-r/min Flat-style Servomotors (100 V AC)

The following graphs show the characteristics with a 3-m standard cable and 100-V AC input.

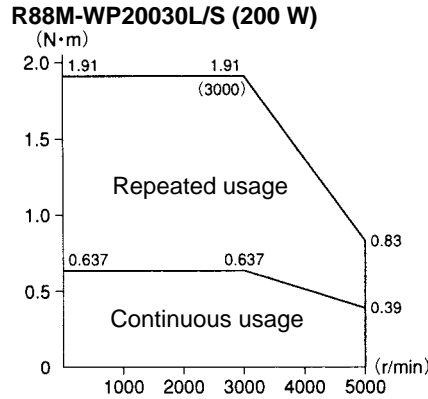
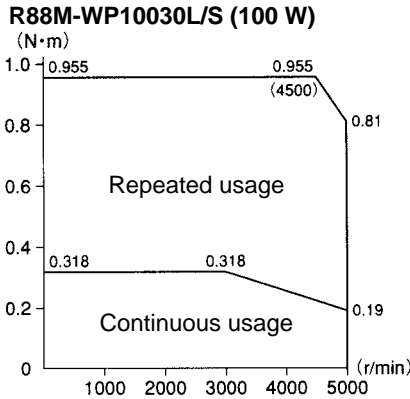

3,000-r/min Flat-style Servomotors (200 V AC)

The following graphs show the characteristics with a 3-m standard cable and 200-V AC input.

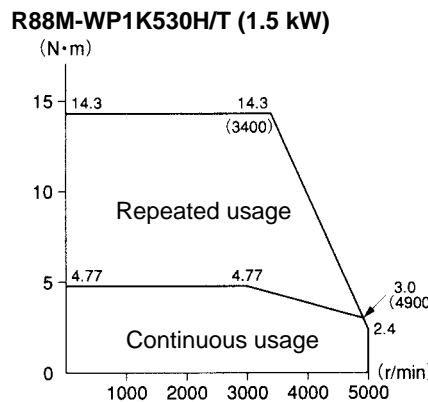
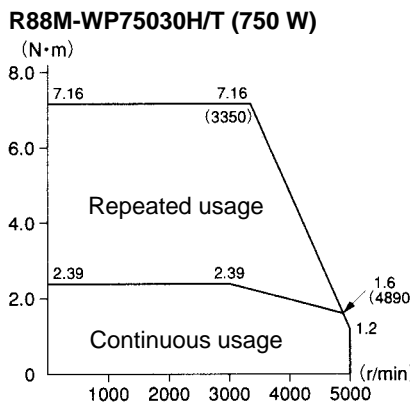
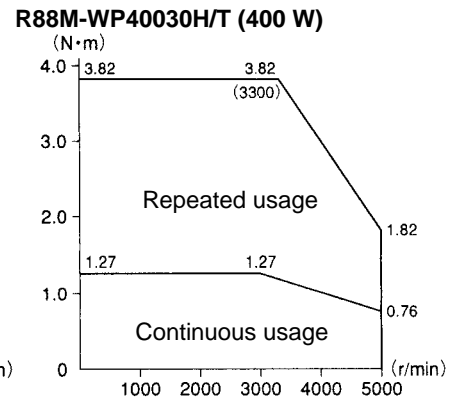
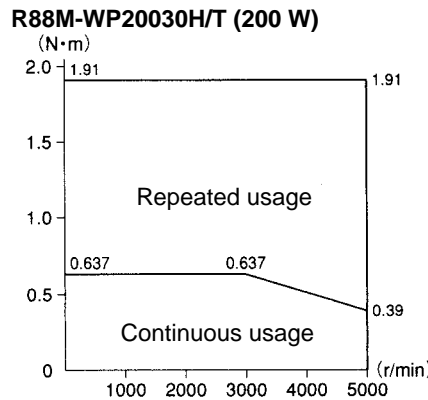
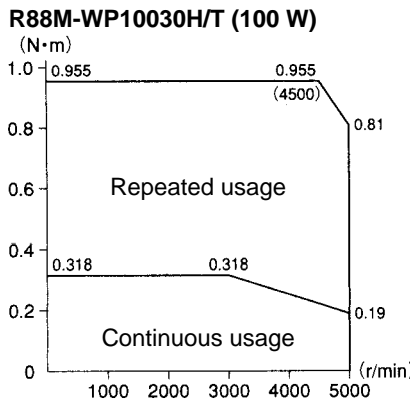

• Servomotor and Mechanical System Temperature Characteristics

- W-series AC Servomotors use rare earth magnets (neodymium-iron magnets). The temperature coefficient for these magnets is approximately $-0.13\%/^{\circ}\text{C}$. As the temperature drops, the Servomotor's momentary maximum torque increases, and as the temperature rises the Servomotor's momentary

maximum torque decreases. When the normal temperature of 20°C and –10°C are compared, the momentary maximum torque increases by approximately 4%. Conversely, when the magnet warms up to 80°C from the normal temperature of 20°C, the momentary maximum torque decreases by approximately 8%.

- Generally, in a mechanical system, when the temperature drops the friction torque increases and the load torque becomes larger. For that reason, overloading may occur at low temperatures. In particular, in systems which use deceleration devices, the load torque at low temperatures may be nearly twice the load torque at normal temperatures. Check with a current monitor to see whether overloading is occurring at low temperatures, and how much the load torque is. Likewise, check to see whether there abnormal Servomotor overheating or alarms are occurring at high temperatures.
- An increase in load friction torque visibly increases load inertia. Therefore, even if the Servo Driver parameters are adjusted at a normal temperature, there may not be optimal operation at low temperatures. Check to see whether there is optimal operation at low temperatures too.

■ 1,000-r/min Flat-style Servomotors

● Performance Specifications Table

Item	Unit	200 V AC								
		R88M -W30010H	R88M -W60010H	R88M -W90010H	R88M -W1K210 H	R88M -W2K010 H	R88M -W3K010 H	R88M -W4K010 H	R88M -W5K510 H	
		R88M -W30010T	R88M -W60010T	R88M -W90010T	R88M -W1K210 T	R88M -W2K010 T	R88M -W3K010 T	R88M -W4K010 T	R88M -W5K510 T	
Rated output*	W	300	600	900	1,200	2,000	3,000	4,000	5,500	
Rated torque*	N•m	2.84	5.68	8.62	11.5	19.1	28.4	38.2	52.6	
Rated rotation speed	r/min	1,000								
Momentary maximum rotation speed	r/min	2,000								
Momentary maximum torque*	N•m	7.17	14.1	19.3	28.0	44.0	63.7	107	137	
Rated current*	A (rms)	3.0	5.7	7.6	11.6	18.5	24.8	30.0	43.2	
Momentary maximum current*	A (rms)	7.3	13.9	16.6	28	42	56	84	110	
Rotor inertia	kg•m ² (GD ² /4)	7.24 × 10 ⁻⁴	1.39 × 10 ⁻³	2.05 × 10 ⁻³	3.17 × 10 ⁻³	4.60 × 10 ⁻³	6.75 × 10 ⁻³	8.90 × 10 ⁻³	1.25 × 10 ⁻²	
Torque constant*	N•m/A	1.03	1.06	1.21	1.03	1.07	1.19	1.34	1.26	
Power rate*	kW/s	11.2	23.2	36.3	41.5	79.4	120	164	221	
Mechanical time constant	ms	5.1	3.8	2.8	2.0	1.7	1.4	1.3	1.1	
Electrical time constant	ms	5.1	4.7	5.7	13.5	13.9	15.5	14.6	16.5	
Allowable radial load	N	490	490	686	1,176	1,470	1,470	1,764	1,764	
Allowable thrust load	N	98	98	343	490	490	490	588	588	
Weight	Without brake	kg	Approx. 5.5	Approx. 7.6	Approx. 9.6	Approx. 14	Approx. 18	Approx. 23	Approx. 30	Approx. 40
	With brake	kg	Approx. 7.5	Approx. 9.6	Approx. 12	Approx. 19	Approx. 23.5	Approx. 28.5	Approx. 35	Approx. 45.5
Radiation shield dimensions (material)		t20 × □400 mm (Fe)				t30 × □550 mm (Fe)				
Applicable load inertia		See note 6.								
Applicable Servo Driver (R88D-)		WT05H	WT08H	WT10H	WT15H	WT20H	WT30H	WT50H	WT60H	

Item	Unit	200 V AC									
		R88M -W30010H	R88M -W60010H	R88M -W90010H	R88M -W1K210 H	R88M -W2K010 H	R88M -W3K010 H	R88M -W4K010 H	R88M -W5K510 H		
		R88M -W30010T	R88M -W60010T	R88M -W90010T	R88M -W1K210 T	R88M -W2K010 T	R88M -W3K010 T	R88M -W4K010 T	R88M -W5K510 T		
Brake specifications	Brake inertia	kg•m ² (GD ² /4)	2.1 × 10 ⁻⁴	2.1 × 10 ⁻⁴	2.1 × 10 ⁻⁴	8.5 × 10 ⁻⁴	8.5 × 10 ⁻⁴	8.5 × 10 ⁻⁴	8.5 × 10 ⁻⁴	8.5 × 10 ⁻⁴	
	Excitation voltage	V	24 V DC ±10%								
	Power consumption (at 20°C)	W	9.85	9.85	9.85	18.5	18.5	18.5	23.5	23.5	
	Current consumption (at 20°C)	A	0.41	0.41	0.41	0.77	0.77	0.77	0.98	0.98	
	Static friction torque	N•m	4.41 min.	12.7 min.	12.7 min.	43.1 min.	43.1 min.	43.1 min.	72.6 min.	72.6 min.	
	Attraction time (See note 3.)	ms	180 max.	180 max.	180 max.	180 max.	180 max.	180 max.	180 max.	180 max.	
	Release time (See note 3.)	ms	100 max.	100 max.	100 max.	100 max.	100 max.	100 max.	100 max.	100 max.	
	Backlash		1° (reference value)								
	Rating	–	Continuous								
	Insulation grade	–	Type F								

Note 1. *The values for items marked by asterisks are the values at an armature winding temperature of 100°C, combined with the Servo Driver. Other values are at normal conditions (20°C, 65%). The momentary maximum torque shown above indicates the standard value.

Note 2. The brakes are the non-excitation operation type (released when excitation voltage is applied).

Note 3. The operation time is the measured value (reference value) with a surge killer (CR50500, by Okaya Electric Industries co. LTD) inserted.

Note 4. The allowable radial and thrust loads are the values determined for a service life of 20,000 hours at normal operating temperatures.

Note 5. The value indicated for the allowable radial load is for the position shown in the following diagram.

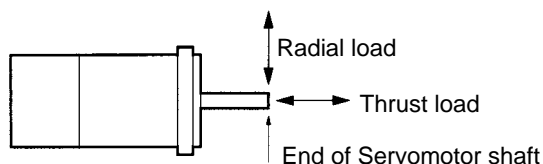

Note 6. Applicable Load Inertia

- 1) The drivable load inertia ratio (load inertia/rotor inertia) changes depending on the mechanical configuration being driven and its rigidity. Highly rigid machines can operate with a large load inertia. Select a Servomotor and verify operation.
- 2) If the dynamic brake is used frequently with a large load inertia, it may lead to burnout of the dynamic brake resistor. Do not repeatedly turn the Servo ON and OFF with the dynamic brake enabled.

• Torque and Rotation Speed Characteristics

1,000-r/min Servomotors (200 V AC)

The following graphs show the characteristics with a 3-m standard cable and 200-V AC input.

R88M-W30010H/T (300 W)

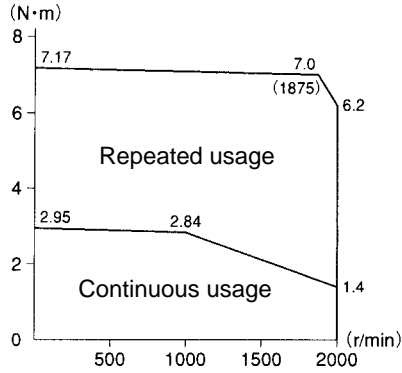

R88M-W60010H/T (600 W)

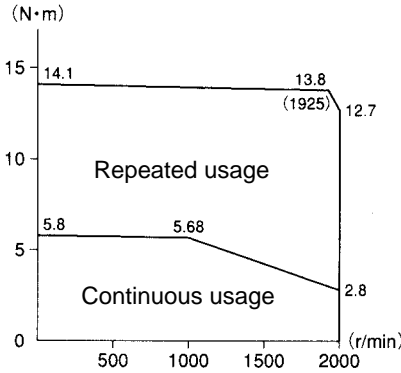

R88M-W90010H/T (900 W)

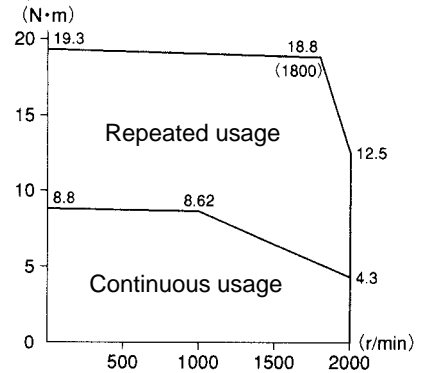

R88M-W1K210H/T (1.2 kW)

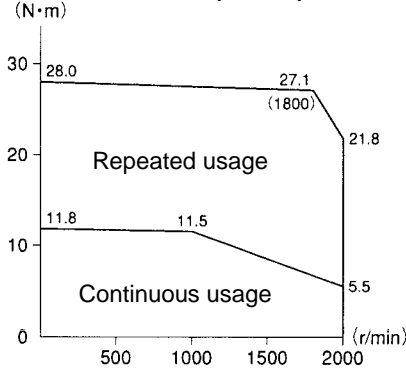

R88M-W2K010H/T (2 kW)

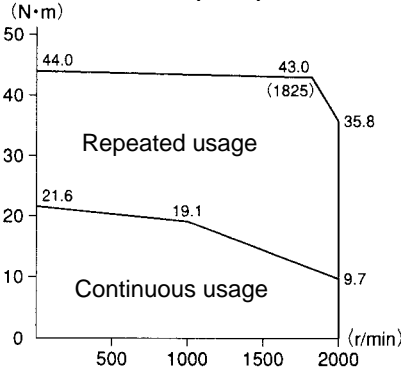

R88M-W3K010H/T (3 kW)

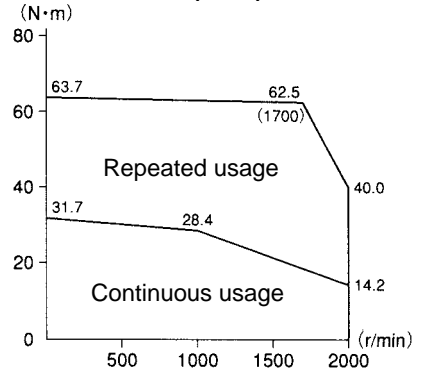

R88M-W4K010H/T (4 kW)

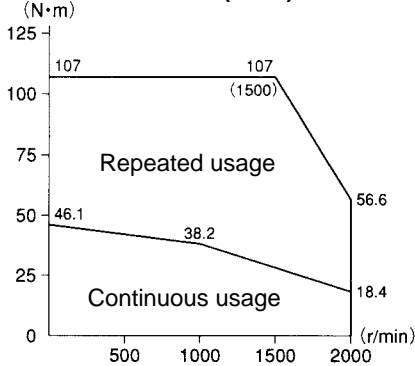

R88M-W5K510H/T (5.5 kW)

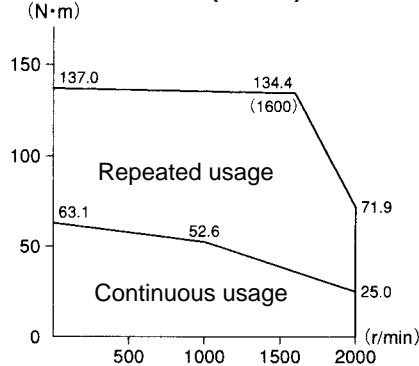

● **Servomotor and Mechanical System Temperature Characteristics**

- W-series AC Servomotors use rare earth magnets (neodymium-iron magnets). The temperature coefficient for these magnets is approximately $-0.13\%/^{\circ}\text{C}$. As the temperature drops, the Servomotor’s momentary maximum torque increases, and as the temperature rises the Servomotor’s momentary maximum torque decreases. When the normal temperature of 20°C and -10°C are compared, the momentary maximum torque increases by approximately 4%. Conversely, when the magnet warms up to 80°C from the normal temperature of 20°C , the momentary maximum torque decreases by approximately 8%.
- Generally, in a mechanical system, when the temperature drops the friction torque increases and the load torque becomes larger. For that reason, overloading may occur at low temperatures. In particular, in systems which use deceleration devices, the load torque at low temperatures may be nearly twice the load torque at normal temperatures. Check with a current monitor to see whether overloading is occurring at low temperatures, and how much the load torque is. Likewise, check to see whether there abnormal Servomotor overheating or alarms are occurring at high temperatures.
- An increase in load friction torque visibly increases load inertia. Therefore, even if the Servo Driver parameters are adjusted at a normal temperature, there may not be optimal operation at low temperatures. Check to see whether there is optimal operation at low temperatures too.

Caution Do not use 900-W, 2-kW, 4-kW, or 5.5-kW Servomotors within the shaded portions of the following diagrams. If used in these regions, the Servomotor may heat, causing the encoder to malfunction.

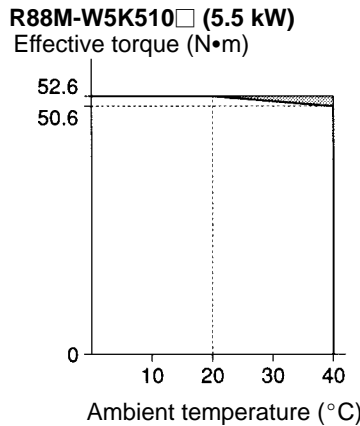
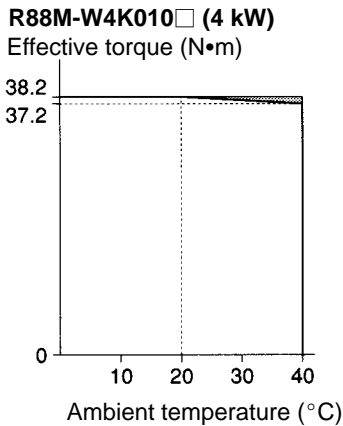
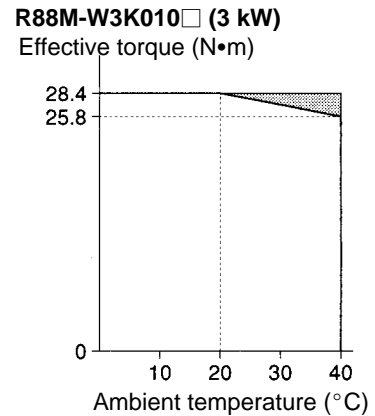
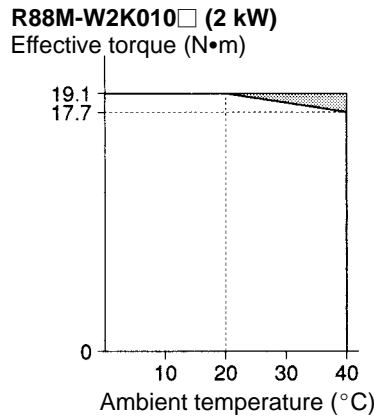
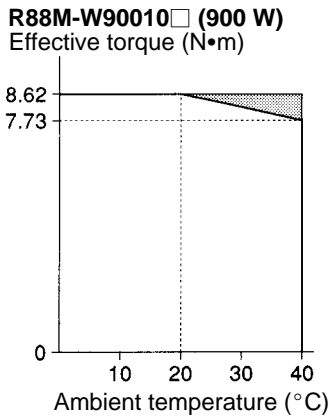

■ 1,500-r/min Servomotors

● Performance Specifications Table

Item	Unit	200 V AC										
		R88M -W45015T	R88M -W85015T	R88M -W1K315T	R88M -W1K815T	R88M -W2K915T	R88M -W4K415T	R88M -W5K515T	R88M -W7K515T	R88M -W11K015T	R88M -W15K015T	
Rated output*	W	450	850	1,300	1,800	2,900	4,400	5,500	7,500	11,000	15,000	
Rated torque*	N•m	2.84	5.39	8.34	11.5	18.6	28.4	35.0	48.0	70.0	95.4	
Rated rotation speed	r/min	1,500										
Momentary maximum rotation speed	r/min	3,000									2,000	
Momentary maximum torque*	N•m	8.92	13.8	23.3	28.7	45.1	71.1	87.6	119	175	224	
Rated current*	A (rms)	3.8	7.1	10.7	16.7	23.8	32.8	42.1	54.7	58.6	78.0	
Momentary maximum current*	A (rms)	11	17	28	42	56	84	110	130	140	170	
Rotor inertia	kg•m ² (GD ² /4)	7.24 × 10 ⁻⁴	1.39 × 10 ⁻³	2.05 × 10 ⁻³	3.17 × 10 ⁻³	4.60 × 10 ⁻³	6.75 × 10 ⁻³	8.90 × 10 ⁻³	1.25 × 10 ⁻²	2.81 × 10 ⁻²	3.15 × 10 ⁻²	
Torque constant*	N•m/A	0.82	0.83	0.84	0.73	0.83	0.91	0.88	0.93	1.25	1.32	
Power rate*	kW/s	11.2	20.9	33.8	41.5	75.3	120	137	184	174	289	
Mechanical time constant	ms	5.0	3.1	2.8	2.2	1.9	1.3	1.3	1.1	1.2	0.98	
Electrical time constant	ms	5.1	5.3	6.3	12.8	12.5	15.7	16.4	18.4	22.6	27.2	
Allowable radial load	N	490	490	686	1,176	1,470	1,470	1,764	1,764	1,764	4,998	
Allowable thrust load	N	98	98	343	490	490	490	588	588	588	2,156	
Weight	Without brake	kg	Approx. 5.5	Approx. 7.6	Approx. 9.6	Approx. 14	Approx. 18	Approx. 23	Approx. 30	Approx. 40	Approx. 57.5	Approx. 86
	With brake	kg	Approx. 7.5	Approx. 9.6	Approx. 12	Approx. 19	Approx. 23.5	Approx. 28.5	Approx. 35	Approx. 45.5	Approx. 65	Approx. 100
Radiation shield dimensions (material)		t20 × □400 mm (Fe)				t30 × □550 mm (Fe)				t35 × □650 mm (Fe)		
Applicable load inertia		See note 6.										
Applicable Servo Driver (R88D-)		WT05H	WT10H	WT15H	WT20H	WT30H	WT50H	WT60H	WT75H	WT150H	WT150H	

Item	Unit	200 V AC										
		R88M-W45015T	R88M-W85015T	R88M-W1K315T	R88M-W1K815T	R88M-W2K915T	R88M-W4K415T	R88M-W5K515T	R88M-W7K515T	R88M-W11K015T	R88M-W15K015T	
Brake specifications	Brake inertia	kg•m ² (GD ² /4)	2.1 × 10 ⁻⁴	2.1 × 10 ⁻⁴	2.1 × 10 ⁻⁴	8.5 × 10 ⁻⁴	8.5 × 10 ⁻⁴	8.5 × 10 ⁻⁴	8.5 × 10 ⁻⁴	8.5 × 10 ⁻⁴	1.88 × 10 ⁻³	3.75 × 10 ⁻³
	Excitation voltage	V	24 V DC ±10%									
	Power consumption (at 20°C)	W	9.85	9.85	9.85	18.5	18.5	18.5	23.5	23.5	32	35
	Current consumption (at 20°C)	A	0.41	0.41	0.41	0.77	0.77	0.77	0.98	0.98	1.33	1.46
	Static friction torque	N•m	4.41 min.	12.7 min.	12.7 min.	43.1 min.	43.1 min.	43.1 min.	72.6 min.	72.6 min.	84.3 min.	115 min.
	Attraction time (See note 3.)	ms	180 max.	180 max.	180 max.	180 max.	180 max.	180 max.	180 max.	180 max.	170 max.	250 max.
	Release time (See note 3.)	ms	100 max.	100 max.	100 max.	100 max.	100 max.	100 max.	100 max.	100 max.	80 max.	80 max.
	Backlash		1° (reference value)									
	Rating	–	Continuous									
	Insulation grade	–	Type F									

Note 1. *The values for items marked by asterisks are the values at an armature winding temperature of 20°C, combined with the Servo Driver. Other values are at normal conditions (20°C, 65%). The momentary maximum torque shown above indicates the standard value.

Note 2. The brakes are the non-excitation operation type (released when excitation voltage is applied).

Note 3. The operation time is the measured value (reference value) with a surge killer (CR50500, by Okaya Electric Industries co. LTD) inserted.

Note 4. The allowable radial and thrust loads are the values determined for a service life of 20,000 hours at normal operating temperatures.

Note 5. The value indicated for the allowable radial load is for the position shown in the following diagram.

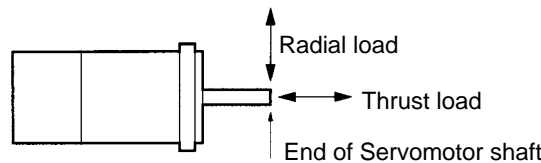

Note 6. Applicable Load Inertia

- 1) The drivable load inertia ratio (load inertia/rotor inertia) changes depending on the mechanical configuration being driven and its rigidity. Highly rigid machines can operate with a large load inertia. Select a Servomotor and verify operation.
- 2) If the dynamic brake is used frequently with a large load inertia, it may lead to burnout of the dynamic brake resistor. Do not repeatedly turn the Servo ON and OFF with the dynamic brake enabled.

• Torque and Rotation Speed Characteristics

1,500-r/min Servomotors (200 V AC)

The following graphs show the characteristics with a 3-m standard cable and 200-V AC input.

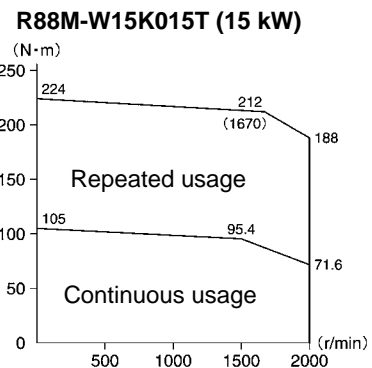
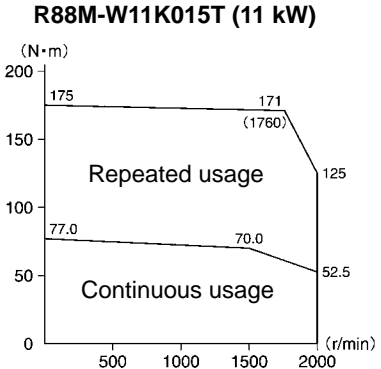
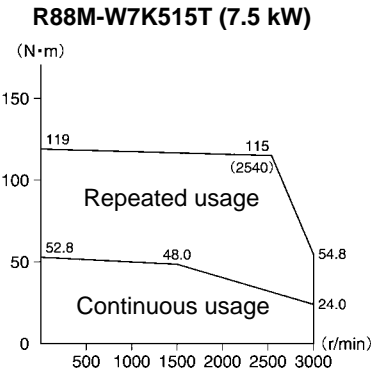
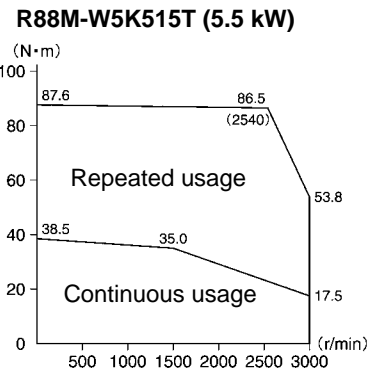
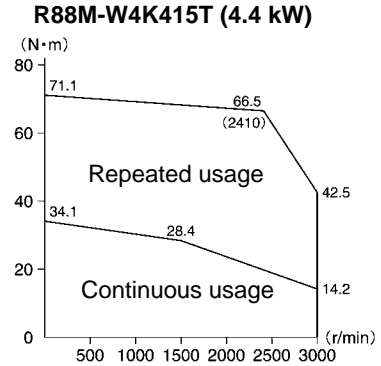
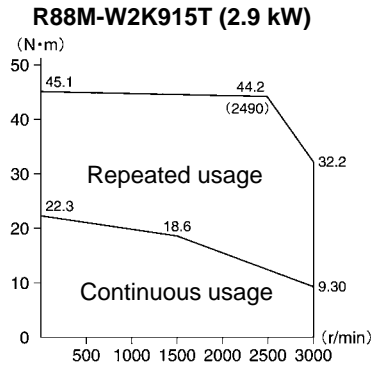
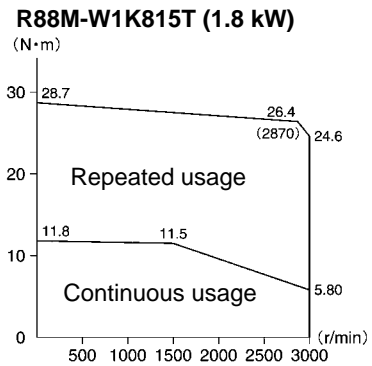
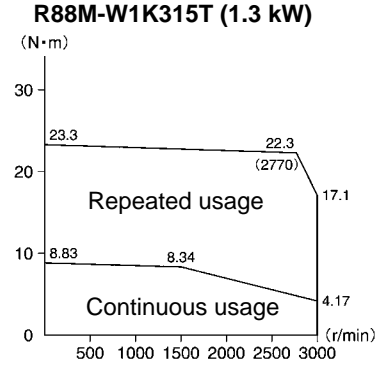
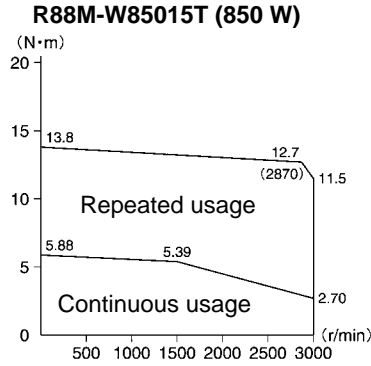
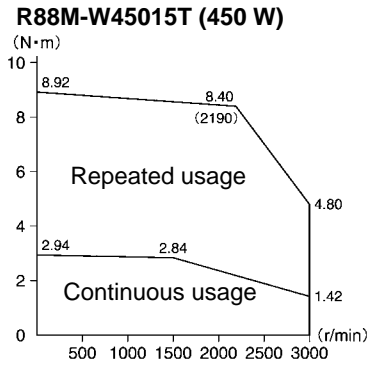

● **Servomotor and Mechanical System Temperature Characteristics**

- W-series AC Servomotors use rare earth magnets (neodymium-iron magnets). The temperature coefficient for these magnets is approximately $-0.13\%/^{\circ}\text{C}$. As the temperature drops, the Servomotor’s momentary maximum torque increases, and as the temperature rises the Servomotor’s momentary maximum torque decreases. When the normal temperature of 20°C and -10°C are compared, the momentary maximum torque increases by approximately 4%. Conversely, when the magnet warms up to 80°C from the normal temperature of 20°C , the momentary maximum torque decreases by approximately 8%.
- Generally, in a mechanical system, when the temperature drops the friction torque increases and the load torque becomes larger. Therefore, overloading may occur at low temperatures. In particular, in systems which use deceleration devices, the load torque at low temperatures may be nearly twice the load torque at normal temperatures. Check with a current monitor to see whether overloading is occurring at low temperatures, and how much the load torque is. Likewise, check to see whether there is abnormal Servomotor overheating or alarms are occurring at high temperatures.
- An increase in load friction torque visibly increases load inertia. Therefore, even if the Servo Driver parameters are adjusted at a normal temperature, there may not be optimal operation at low temperatures. Check to see whether there is optimal operation at low temperatures too.

Caution Do not use 1.3-kW, 2.9-kW, 4.4-kW, 5.5-kW, 7.5-kW, 11-kW, or 15-kW Servomotors within the shaded portions of the following diagrams. If used in these regions, the Servomotor may overheat, causing the encoder to malfunction.

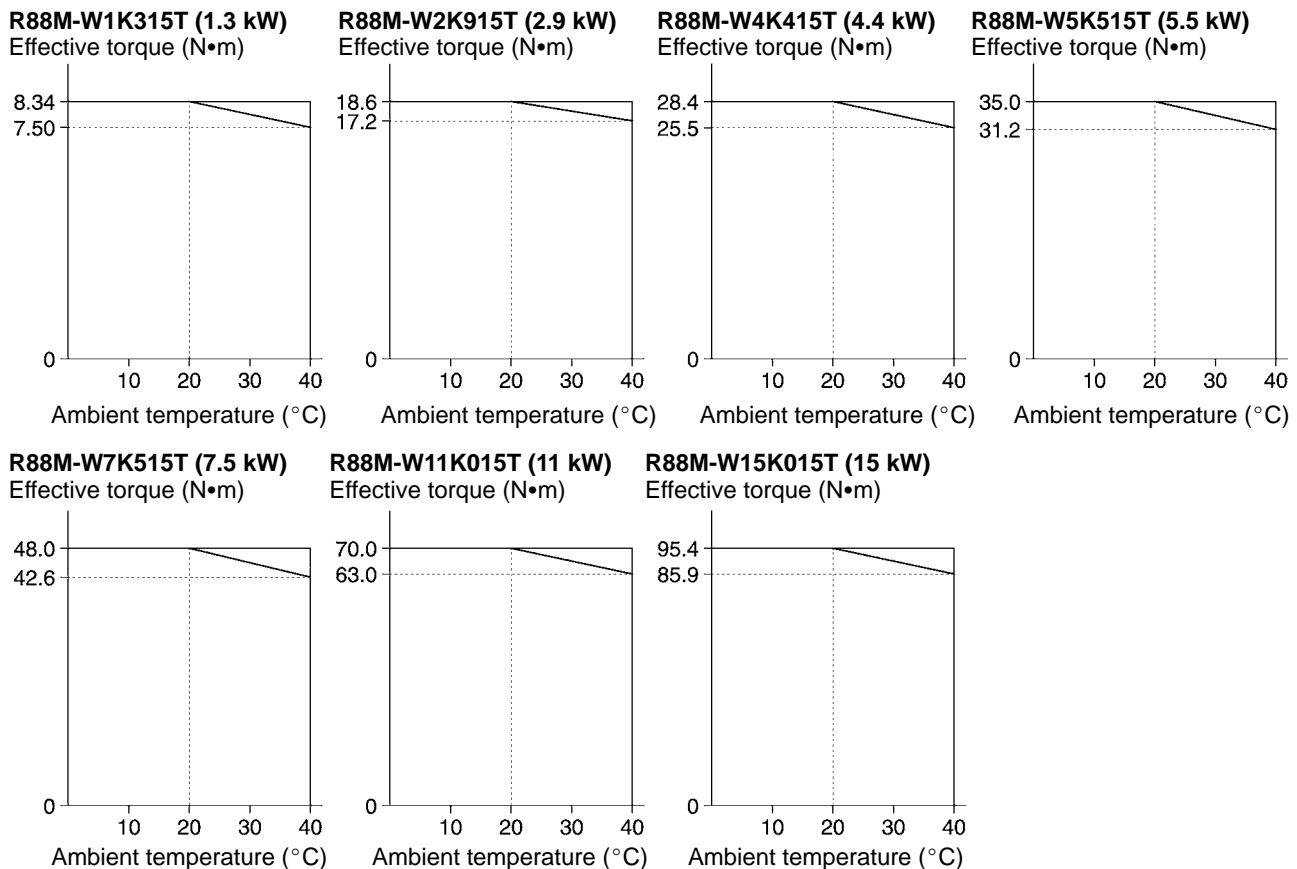

2-5-3 Specifications for Servomotors with Reduction Gears

■ 3,000-r/min Servomotors with Standard Reduction Gears (30 W to 5 kW)

	Model		Rated rotation speed	Rated torque	Ratio	Maximum momentary rotation speed	Maximum momentary torque	Reduction gear inertia	Allowable radial load	Allowable thrust load	Weight	
											Without brake	With brake
			r/min	N·m	%	r/min	N·m	kg·m ²	N	N	kg	kg
30 W	1/5	R88M-W03030□-□G05BJ	600	0.238	50	800	0.72	3.64×10^{-6}	137	127	1.0	1.3
	1/9	R88M-W03030□-□G09BJ	333	0.599	70	444	1.80	1.24×10^{-6}	176	127	1.0	1.3
	1/21	R88M-W03030□-□G21BJ	143	1.60	80	190	4.80	8.4×10^{-7}	176	127	1.0	1.3
	1/33	R88M-W03030□-□G33BJ	91	2.51	80	121	7.55	6.4×10^{-7}	176	127	1.0	1.3
50 W	1/5	R88M-W05030□-□G05BJ	600	0.557	70	800	1.67	3.60×10^{-6}	137	127	1.1	1.4
	1/9	R88M-W05030□-□G09BJ	333	1.00	70	444	3.01	3.30×10^{-6}	206	147	1.4	1.7
	1/21	R88M-W05030□-□G21BJ	143	2.67	80	190	8.01	1.80×10^{-6}	235	147	1.6	1.9
	1/33	R88M-W05030□-□G33BJ	91	4.20	80	121	12.6	1.3×11^{-6}	235	147	1.6	1.9
100 W	1/5	R88M-W10030□-□G05BJ	600	1.27	80	800	3.82	7.76×10^{-6}	167	147	1.4	1.7
	1/11	R88M-W10030□-□G11BJ	273	2.80	80	364	8.40	4.76×10^{-6}	216	147	1.7	2.0
	1/21	R88M-W10030□-□G21BJ	143	5.34	80	190	16.0	4.26×10^{-6}	392	235	2.7	3.0
	1/33	R88M-W10030□-□G33BJ	91	8.40	80	121	25.2	3.26×10^{-6}	431	235	2.7	3.0
200 W	1/5	R88M-W20030□-□G05BJ	600	2.55	80	800	7.64	3.35×10^{-5}	245	235	3.0	3.5
	1/11	R88M-W20030□-□G11BJ	273	5.96	85	364	17.9	8.50×10^{-6}	323	235	3.5	4.0
	1/21	R88M-W20030□-□G21BJ	143	11.4	85	190	34.1	1.10×10^{-5}	549	294	3.7	4.2
	1/33	R88M-W20030□-□G33BJ	91	17.9	85	121	53.6	6.50×10^{-6}	608	294	3.8	4.3
400 W	1/5	R88M-W40030□-□G05BJ	600	5.40	85	800	16.2	3.35×10^{-5}	245	235	3.6	4.1
	1/11	R88M-W40030□-□G11BJ	273	11.9	85	364	35.7	1.95×10^{-5}	441	294	4.3	4.8
	1/21	R88M-W40030□-□G21BJ	143	22.7	85	190	68.2	1.95×10^{-5}	568	314	4.7	5.2
	1/33	R88M-W40030□-□G33BJ	91	33.5	80	121	101	1.73×10^{-5}	657	314	7.1	7.6
750 W	1/5	R88M-W75030□-□G05BJ	600	10.2	85	800	30.4	5.83×10^{-5}	343	294	5.8	6.7
	1/11	R88M-W75030□-□G11BJ	273	22.3	85	364	67.0	5.28×10^{-5}	451	314	6.6	7.5
	1/21	R88M-W75030□-□G21BJ	143	42.7	85	190	128	5.93×10^{-5}	813	490	9.9	10.8
	1/33	R88M-W75030□-□G33BJ	91	67.0	85	121	201	2.63×10^{-5}	921	490	9.9	10.8
1 kW	1/5	R88M-W1K030□-□G05BJ	600	12.7	80	800	38.2	3.44×10^{-4}	833	1,280	13	14.4
	1/9	R88M-W1K030□-□G09BJ	333	22.9	80	444	68.7	3.11×10^{-4}	980	1,570	13	14.4
	1/20	R88M-W1K030□-□G20BJ	150	50.9	80	200	153	6.79×10^{-4}	2,650	4,220	30	31.4
	1/29	R88M-W1K030□-□G29BJ	103	73.8	80	138	221	4.88×10^{-4}	2,940	4,900	30	31.4
	1/45	R88M-W1K030□-□G45BJ	67	114	80	89	343	3.92×10^{-4}	3,430	5,690	30	31.4
1.5 kW	1/5	R88M-W1K530□-□G05BJ	600	19.6	80	800	58.8	3.44×10^{-4}	833	1,280	14	15.7
	1/9	R88M-W1K530□-□G09BJ	333	35.3	80	444	106	4.77×10^{-4}	1,960	3,000	31	32.7
	1/20	R88M-W1K530□-□G20BJ	150	78.4	80	200	235	6.79×10^{-4}	2,650	4,220	31	32.7
	1/29	R88M-W1K530□-□G29BJ	103	114	80	138	341	4.88×10^{-4}	2,940	4,900	31	32.7
	1/45	R88M-W1K530□-□G45BJ	67	176	80	89	529	6.58×10^{-4}	8,040	8,830	51	52.5
2 kW	1/5	R88M-W2K030□-□G05BJ	600	25.4	80	800	76.4	3.44×10^{-4}	833	1,280	15	16.5
	1/9	R88M-W2K030□-□G09BJ	333	45.8	80	444	138	4.77×10^{-4}	1,960	3,000	32	33.5
	1/20	R88M-W2K030□-□G20BJ	150	102	80	200	306	6.79×10^{-4}	2,650	4,220	32	33.5
	1/29	R88M-W2K030□-□G29BJ	103	148	80	138	443	1.03×10^{-3}	6,860	7,350	52	53.5
	1/45	R88M-W2K030□-□G45BJ	67	229	80	89	688	6.58×10^{-4}	8,040	8,830	52	53.5
3 kW	1/5	R88M-W3K030□-□G05BJ	600	39.2	80	800	118	1.02×10^{-3}	1,670	1,960	29	32
	1/9	R88M-W3K030□-□G09BJ	333	70.6	80	444	212	7.80×10^{-4}	1,960	3,000	36	39
	1/20	R88M-W3K030□-□G20BJ	150	157	80	200	470	2.02×10^{-3}	6,080	6,370	56	58.5
	1/29	R88M-W3K030□-□G29BJ	103	227	80	138	682	1.34×10^{-3}	6,860	7,350	56	58.5
	1/45	R88M-W3K030□-□G45BJ	67	353	80	89	1,058	9.70×10^{-4}	8,040	8,830	56	58.5
4 kW	1/5	R88M-W4K030□-□G05BJ	600	50.4	80	800	151	1.02×10^{-3}	1,670	1,960	32	35
	1/9	R88M-W4K030□-□G09BJ	333	90.7	80	444	272	1.25×10^{-3}	4,700	4,320	59	62
	1/20	R88M-W4K030□-□G20BJ	150	202	80	200	605	2.02×10^{-3}	6,080	6,370	59	62
	1/29	R88M-W4K030□-□G29BJ	103	292	80	138	877	1.34×10^{-3}	6,860	7,350	59	62
5 kW	1/5	R88M-W5K030□-□G05BJ	600	63.2	80	800	190	2.04×10^{-3}	3,820	2,940	52	55
	1/9	R88M-W5K030□-□G09BJ	333	114	80	444	343	1.25×10^{-3}	4,700	4,320	62	65
	1/20	R88M-W5K030□-□G20BJ	150	253	80	200	762	2.02×10^{-3}	6,080	6,370	62	65

- Note 1.** The reduction gear inertia indicates the Servomotor shaft conversion value.
- Note 2.** The enclosure rating for Servomotors with reduction gears is IP55 for 30- to 750-W models, and IP44 for 1- to 5-kW models.
- Note 3.** The maximum momentary rotation speed for the motor shaft of Servomotors with reduction gears is 4,000 r/min.
- Note 4.** The maximum momentary torque values marked by asterisks are the maximum allowable torque for the reduction gears. Use torque limits so that these values are not exceeded.
- Note 5.** The allowable radial loads are measured at a point 5 mm from the end of the shaft for 30- to 750-W Servomotors and in the center of the shaft for 1- to 5-W Servomotors.

■ 3,000-r/min Flat-style Servomotors with Standard Reduction Gears (100 W to 1.5 kW)

Model			Rated rotation speed	Rated torque	Efficiency	Maximum momentary rotation speed	Maximum momentary torque	Reduction gear inertia	Allowable radial load	Allowable thrust load	Weight	
											With-out brake	With brake
			r/min	N•m	%	r/min	N•m	kg•m ²	N	N	kg	kg
100 W	1/5	R88M-WP10030□-□G05BJ	600	1.27	80	800	3.82	9.29 × 10 ⁻⁶	167	147	1.5	1.7
	1/11	R88M-WP10030□-□G11BJ	273	2.80	80	364	8.40	4.79 × 10 ⁻⁶	216	147	1.5	1.7
	1/21	R88M-WP10030□-□G21BJ	143	5.34	80	190	16.0	4.29 × 10 ⁻⁶	392	235	3.0	3.2
	1/33	R88M-WP10030□-□G33BJ	91	8.40	80	121	25.2	3.29 × 10 ⁻⁶	431	235	3.0	3.2
200 W	1/5	R88M-WP20030□-□G05BJ	600	2.55	80	800	7.64	3.60 × 10 ⁻⁵	245	235	3.5	4.0
	1/11	R88M-WP20030□-□G11BJ	273	5.96	85	364	17.9	8.80 × 10 ⁻⁶	323	235	3.8	4.3
	1/21	R88M-WP20030□-□G21BJ	143	11.4	85	190	34.1	1.10 × 10 ⁻⁵	549	294	4.1	4.6
	1/33	R88M-WP20030□-□G33BJ	91	17.9	85	121	53.6	6.50 × 10 ⁻⁶	608	294	4.1	4.6
400 W	1/5	R88M-WP40030□-□G05BJ	600	5.40	85	800	16.2	3.60 × 10 ⁻⁵	245	235	4.2	4.7
	1/11	R88M-WP40030□-□G11BJ	273	11.9	85	364	35.7	1.95 × 10 ⁻⁵	441	294	4.8	5.3
	1/21	R88M-WP40030□-□G21BJ	143	22.7	85	190	68.2	1.95 × 10 ⁻⁵	568	314	5.2	5.7
	1/33	R88M-WP40030□-□G33BJ	91	33.5	80	121	101	1.72 × 10 ⁻⁵	657	314	7.7	8.2
750 W	1/5	R88M-WP75030□-□G05BJ	600	10.2	85	800	30.4	7.65 × 10 ⁻⁵	343	294	6.9	8.4
	1/11	R88M-WP75030□-□G11BJ	273	22.3	85	364	67.0	5.23 × 10 ⁻⁵	451	314	8.0	9.5
	1/21	R88M-WP75030□-□G21BJ	143	42.7	85	190	128	6.63 × 10 ⁻⁵	813	490	11.0	12.5
	1/33	R88M-WP75030□-□G33BJ	91	67.0	85	121	201	4.55 × 10 ⁻⁵	921	490	11.0	12.5
1.5 kW	1/5	R88M-WP1K530□-□G05BJ	600	20.3	85	800	60.8	1.54 × 10 ⁻⁴	353	314	11.6	13.1
	1/11	R88M-WP1K530□-□G11BJ	273	44.6	85	364	134	2.09 × 10 ⁻⁴	647	490	13.7	15.2
	1/21	R88M-WP1K530□-□G21BJ	143	80.1	80	190	270	1.98 × 10 ⁻⁴	1,274	882	23.6	25.1
	1/33	R88M-WP1K530□-□G33BJ	91	126	80	121	353	1.12 × 10 ⁻⁴	1,274	882	23.6	25.1

- Note 1.** The reduction gear inertia indicates the Servomotor shaft conversion value.
- Note 2.** The enclosure rating for Servomotors with reduction gears is IP55.
- Note 3.** The maximum momentary rotation speed for the motor shaft of Servomotors with reduction gears is 4,000 r/min.
- Note 4.** The maximum momentary torque values marked by asterisks are the maximum allowable torque for the reduction gears. Use torque limits so that these values are not exceeded.
- Note 5.** The allowable radial loads are measured at a point 5 mm from the end of the shaft.

■ 1,000-r/min Servomotors with Standard Reduction Gears (300 W to 3 kW)

Model			Rated rotation speed	Rated torque	Efficiency	Maximum momentary rotation speed	Maximum momentary torque	Reduction gear inertia	Allowable radial load	Allowable thrust load	Weight	
											Without brake	With brake
			r/min	N•m	%	r/min	N•m	kg•m ²	N	N	kg	kg
300 W	1/5	R88M-W30010□-□G05BJ	200	11.4	80	400	28.7	1.26 × 10 ⁻⁴	883	1,280	14	16
	1/9	R88M-W30010□-□G09BJ	111	20.4	80	222	51.6	9.40 × 10 ⁻⁵	980	1,570	14	16
	1/20	R88M-W30010□-□G20BJ	50	45.4	80	100	115	1.40 × 10 ⁻⁴	1,270	2,260	16	18
	1/29	R88M-W30010□-□G29BJ	34	65.9	80	69	166	2.76 × 10 ⁻⁴	2,940	4,900	31	33
	1/45	R88M-W30010□-□G45BJ	22	102	80	44	258	1.81 × 10 ⁻⁴	3,430	5,690	31	33
600 W	1/5	R88M-W60010□-□G05BJ	200	22.7	80	400	56.4	1.30 × 10 ⁻⁴	833	1,280	16	18
	1/9	R88M-W60010□-□G09BJ	111	40.9	80	222	*82.5	9.00 × 10 ⁻⁵	980	1,570	16	18
	1/20	R88M-W60010□-□G20BJ	50	90.9	80	100	226	4.70 × 10 ⁻⁴	2,650	4,220	33	35
	1/29	R88M-W60010□-□G29BJ	34	132	80	69	327	2.80 × 10 ⁻⁴	2,940	4,900	33	35
	1/45	R88M-W60010□-□G45BJ	22	204	80	44	508	4.50 × 10 ⁻⁴	8,040	8,830	53	55
900 W	1/5	R88M-W90010□-□G05BJ	200	34.5	80	400	77.2	3.40 × 10 ⁻⁴	833	1,280	18	20.4
	1/9	R88M-W90010□-□G09BJ	111	62.1	80	222	139	4.80 × 10 ⁻⁴	1,960	3,000	35	37.4
	1/20	R88M-W90010□-□G20BJ	50	138	80	100	309	6.90 × 10 ⁻⁴	2,650	4,220	35	37.4
	1/29	R88M-W90010□-□G29BJ	34	200	80	69	448	1.04 × 10 ⁻³	6,860	7,350	55	57.4
	1/45	R88M-W90010□-□G45BJ	22	310	80	44	695	6.70 × 10 ⁻⁴	8,040	8,830	55	57.4
1.2 kW	1/5	R88M-W1K210□-□G05BJ	200	46.0	80	400	112	1.02 × 10 ⁻³	1,670	1,960	32	37
	1/9	R88M-W1K210□-□G09BJ	111	82.8	80	222	202	7.80 × 10 ⁻⁴	1,960	3,000	39	44
	1/20	R88M-W1K210□-□G20BJ	50	184	80	100	448	2.02 × 10 ⁻³	6,080	6,370	59	64
	1/29	R88M-W1K210□-□G29BJ	34	267	80	69	650	1.34 × 10 ⁻³	6,860	7,350	59	64
	1/45	R88M-W1K210□-□G45BJ	22	414	80	44	1,008	9.70 × 10 ⁻⁴	8,040	8,830	59	64
2 kW	1/5	R88M-W2K010□-□G05BJ	200	76.4	80	400	176	1.02 × 10 ⁻³	1,670	1,960	36	41.5
	1/9	R88M-W2K010□-□G09BJ	111	138	80	222	317	7.80 × 10 ⁻⁴	1,960	3,000	43	48.5
	1/20	R88M-W2K010□-□G20BJ	50	306	80	100	704	2.02 × 10 ⁻³	6,080	6,370	63	68.5
3 kW	1/5	R88M-W3K010□-□G05BJ	200	114	80	400	255	2.04 × 10 ⁻³	3,820	2,940	58	63.5
	1/9	R88M-W3K010□-□G09BJ	111	204	80	222	459	1.25 × 10 ⁻³	4,700	4,320	68	73.5

Note 1. The reduction gear inertia indicates the Servomotor shaft conversion value.

Note 2. The enclosure rating for Servomotors with reduction gears is IP44.

Note 3. The maximum momentary torque values marked by asterisks are the maximum allowable torque for the reduction gears. Use torque limits so that these values are not exceeded.

Note 4. The allowable radial loads are measured in the center of the shaft.

■ 1,500-r/min Servomotors with Standard Reduction Gears (450 W to 4.4 kW)

Model			Rated rotation speed	Rated torque	Efficiency	Maximum momentary rotation speed	Maximum momentary torque	Reduction gear inertia	Allowable radial load	Allowable thrust load	Weight	
											Without brake	With brake
			r/min	N•m	%	r/min	N•m	kg•m ²	N	N	kg	kg
450 W	1/5	R88M-W45015T-□G05BJ	300	11.4	80	600	35.7	1.26×10^{-4}	883	1,280	14	16
	1/9	R88M-W45015T-□G09BJ	167	20.4	80	333	64.2	9.40×10^{-5}	980	1,570	14	16
	1/20	R88M-W45015T-□G20BJ	75	45.4	80	150	143	4.66×10^{-4}	2,650	4,220	31	33
	1/29	R88M-W45015T-□G29BJ	52	65.9	80	103	207	2.76×10^{-4}	2,940	4,900	31	33
	1/45	R88M-W45015T-□G45BJ	33	102	80	67	321	1.81×10^{-4}	3,430	5,690	31	33
850 W	1/5	R88M-W85015T-□G05BJ	300	21.6	80	400	55.2	1.30×10^{-4}	883	1,280	16	18
	1/9	R88M-W85015T-□G09BJ	167	38.8	80	222	*74.5	9.00×10^{-5}	980	1,570	16	18
	1/20	R88M-W85015T-□G20BJ	75	86.2	80	100	221	4.70×10^{-4}	2,650	4,220	33	35
	1/29	R88M-W85015T-□G29BJ	52	125	80	69	320	2.80×10^{-4}	2,940	4,900	33	35
	1/45	R88M-W85015T-□G45BJ	33	194	80	44	497	4.50×10^{-4}	8,040	8,830	53	55
1.3 kW	1/5	R88M-W1K315T-□G05BJ	300	33.4	80	400	93.2	7.20×10^{-4}	1,670	1,960	28	30.4
	1/9	R88M-W1K315T-□G09BJ	167	60.0	80	222	168	4.80×10^{-4}	1,960	3,000	35	37.4
	1/20	R88M-W1K315T-□G20BJ	75	133	80	100	373	6.90×10^{-4}	2,650	4,220	35	37.4
	1/29	R88M-W1K315T-□G29BJ	52	193	80	69	541	1.04×10^{-3}	6,860	7,350	55	57.4
	1/45	R88M-W1K315T-□G45BJ	33	300	80	44	839	6.70×10^{-4}	8,040	8,830	55	57.4
1.8 kW	1/5	R88M-W1K815T-□G05BJ	300	46.0	80	400	115	1.02×10^{-3}	1,670	1,960	32	37
	1/9	R88M-W1K815T-□G09BJ	167	82.8	80	222	207	7.80×10^{-4}	1,960	3,000	39	44
	1/20	R88M-W1K815T-□G20BJ	75	184	80	100	459	2.02×10^{-3}	6,080	6,370	59	64
	1/29	R88M-W1K815T-□G29BJ	52	267	80	69	666	1.34×10^{-3}	6,860	7,350	59	64
2.9 kW	1/5	R88M-W2K915T-□G05BJ	300	74.4	80	400	182	2.04×10^{-3}	3,820	2,940	53	58.5
	1/9	R88M-W2K915T-□G09BJ	167	134	80	222	325	1.25×10^{-3}	4,700	4,320	63	68.5
	1/20	R88M-W2K915T-□G20BJ	75	298	80	100	730	2.02×10^{-3}	6,080	6,370	63	68.5
4.4 kW	1/5	R88M-W4K415T-□G05BJ	300	114	80	400	284	2.04×10^{-3}	3,820	2,940	58	63.5
	1/9	R88M-W4K415T-□G09BJ	167	204	80	222	512	1.25×10^{-3}	4,700	4,320	68	73.5

Note 1. The reduction gear inertia indicates the Servomotor shaft conversion value.

Note 2. The enclosure rating for Servomotors with reduction gears is IP44.

Note 3. The maximum momentary torque values marked by asterisks are the maximum allowable torque for the reduction gears. Use torque limits so that these values are not exceeded.

Note 4. The allowable radial loads are measured in the center of the shaft.

■ 3,000-r/min Servomotors with Economy Reduction Gears (100 to 750 W)

Model			Rated rotation speed	Rated torque	Efficiency	Maximum momentary rotation speed	Maximum momentary torque	Reduction gear inertia	Allowable radial load	Allowable thrust load	Weight	
											Without brake	With brake
			r/min	N•m	%	r/min	N•m	kg•m ²	N	N	kg	kg
100 W	1/5	R88M-W10030□-□G05CJ	600	1.19	75	1,000	3.58	4.08 × 10 ⁻⁶	392	196	1.05	1.35
	1/9	R88M-W10030□-□G09CJ	333	2.29	80	556	6.88	3.43 × 10 ⁻⁶	441	220	1.05	1.35
	1/15	R88M-W10030□-□G15CJ	200	3.82	80	333	11.5	3.62 × 10 ⁻⁶	588	294	1.2	1.5
	1/25	R88M-W10030□-□G25CJ	120	6.36	80	200	19.1	3.92 × 10 ⁻⁶	1,323	661	2.2	2.5
200 W	1/5	R88M-W20030□-□G05CJ	600	2.71	85	1,000	8.12	1.53 × 10 ⁻⁵	392	196	1.82	2.32
	1/9	R88M-W20030□-□G09CJ	333	3.78	66	556	11.3	2.68 × 10 ⁻⁵	931	465	2.8	3.3
	1/15	R88M-W20030□-□G15CJ	200	6.31	66	333	18.9	2.71 × 10 ⁻⁵	1,176	588	3.2	3.7
	1/25	R88M-W20030□-□G25CJ	120	11.1	70	200	33.4	2.67 × 10 ⁻⁵	1,323	661	3.2	3.7
400 W	1/5	R88M-W40030□-□G05CJ	600	5.40	85	1,000	16.2	3.22 × 10 ⁻⁵	784	392	3.4	3.9
	1/9	R88M-W40030□-□G09CJ	333	9.49	83	556	28.5	2.68 × 10 ⁻⁵	931	465	3.4	3.9
	1/15	R88M-W40030□-□G15CJ	200	15.8	83	333	47.6	2.71 × 10 ⁻⁵	1,176	588	3.8	4.3
	1/25	R88M-W40030□-□G25CJ	120	26.4	83	200	79.3	2.79 × 10 ⁻⁵	1,617	808	4.9	5.4
750 W	1/5	R88M-W75030□-□G05CJ	600	10.8	90	1,000	32.2	7.17 × 10 ⁻⁵	784	392	5.5	6.4
	1/9	R88M-W75030□-□G09CJ	333	18.2	85	556	54.7	6.50 × 10 ⁻⁵	1,176	588	6.8	7.7
	1/15	R88M-W75030□-□G15CJ	200	30.4	85	333	91.2	7.09 × 10 ⁻⁵	1,372	686	7.2	8.1
	1/25	R88M-W75030□-□G25CJ	120	50.7	85	200	152	7.05 × 10 ⁻⁵	2,058	1,029	10.6	11.5

Note 1. The reduction gear inertia indicates the Servomotor shaft conversion value.

Note 2. The enclosure rating for Servomotors with reduction gears is IP44.

Note 3. The allowable radial loads are measured in the center of the shaft.

■ 3,000-r/min Flat-style Servomotors with Economy Reduction Gears (100 to 750 W)

Model			Rated rotation speed	Rated torque	Efficiency	Maximum momentary rotation speed	Maximum momentary torque	Reduction gear inertia	Allowable radial load	Allowable thrust load	Weight	
											Without brake	With brake
			r/min	N•m	%	r/min	N•m	kg•m ²	N	N	kg	kg
100 W	1/5	R88M-WP10030□-□G05CJ	600	1.19	75	1,000	3.58	1.60 × 10 ⁻⁵	392	196	1.42	1.62
	1/9	R88M-WP10030□-□G09CJ	333	2.29	80	556	6.88	1.37 × 10 ⁻⁵	441	220	1.42	1.62
	1/15	R88M-WP10030□-□G15CJ	200	3.82	80	333	11.5	3.38 × 10 ⁻⁶	588	294	1.47	1.67
	1/25	R88M-WP10030□-□G25CJ	120	6.36	80	200	19.1	3.68 × 10 ⁻⁶	1,323	661	2.5	2.7
200 W	1/5	R88M-WP20030□-□G05CJ	600	2.71	85	1,000	8.12	1.53 × 10 ⁻⁵	392	196	2.25	2.75
	1/9	R88M-WP20030□-□G09CJ	333	3.78	66	556	11.3	2.56 × 10 ⁻⁵	931	465	3.2	3.7
	1/15	R88M-WP20030□-□G15CJ	200	6.31	66	333	18.9	2.71 × 10 ⁻⁵	1,176	588	3.6	4.1
	1/25	R88M-WP20030□-□G25CJ	120	11.1	70	200	33.4	2.67 × 10 ⁻⁵	1,323	661	3.6	4.1
400 W	1/5	R88M-WP40030□-□G05CJ	600	5.40	85	1,000	16.2	3.23 × 10 ⁻⁵	784	392	3.9	4.4
	1/9	R88M-WP40030□-□G09CJ	333	9.49	83	556	28.5	2.56 × 10 ⁻⁵	931	465	3.9	4.4
	1/15	R88M-WP40030□-□G15CJ	200	15.8	83	333	47.6	2.71 × 10 ⁻⁵	1,176	588	4.3	4.8
	1/25	R88M-WP40030□-□G25CJ	120	26.4	83	200	79.3	2.79 × 10 ⁻⁵	1,617	808	5.4	5.9
750 W	1/5	R88M-WP75030□-□G05CJ	600	10.8	90	1,000	32.2	7.17 × 10 ⁻⁵	784	392	6.7	8.2
	1/9	R88M-WP75030□-□G09CJ	333	18.2	85	556	54.7	6.50 × 10 ⁻⁵	1,176	588	8.0	9.5
	1/15	R88M-WP75030□-□G15CJ	200	30.4	85	333	91.2	6.86 × 10 ⁻⁵	1,372	686	8.4	9.9
	1/25	R88M-WP75030□-□G25CJ	120	50.7	85	200	152	7.05 × 10 ⁻⁵	2,058	1,029	11.8	13.3

Note 1. The reduction gear inertia indicates the Servomotor shaft conversion value.

Note 2. The enclosure rating for Servomotors with reduction gears is IP44.

Note 3. The allowable radial loads are measured in the center of the shaft.

2-5-4 Encoder Specifications

■ Incremental Encoder Specifications

Item	3,000-r/min Servomotors		3,000-r/min Flat-style Servomotors	1,000-r/min Servomotors
	30 to 750 W	1 to 5 kW		
Encoder method	Optical encoder			
	13 bits	17 bits	13 bits	17 bits
Number of output pulses	A, B phase: 2,048 pulses/revolution Z phase: 1 pulse/revolution	A, B phase: 32,768 pulses/revolution Z phase: 1 pulse/revolution	A, B phase: 2,048 pulses/revolution Z phase: 1 pulse/revolution	A, B phase: 32,768 pulses/revolution Z phase: 1 pulse/revolution
Power supply voltage	5 V DC±5%			
Power supply current	120 mA	150 mA	120 mA	150 mA
Maximum rotation speed	5,000 r/min			
Output signals	+S, -S			
Output impedance	Conforming to EIA RS-422A. Output based on LTC1485CS or equivalent.			
Serial communications data	Position data, poll sensor, U, V, W phase, encoder alarm, Servomotor data			
Serial communications method	Bi-directional communications in HDLC format, by Manchester method			

■ Absolute Encoder Specifications

Item	3,000-r/min Servomotors		3,000-r/min Flat-style Servomotors	1,000-r/min Servomotors 1,500-r/min Servomotors
	30 to 750 W	1 to 5 kW		
Encoder method	Optical encoder			
	16 bits	17 bits	16 bits	17 bits
Number of output pulses	A, B phase: 16,384 pulses/revolution Z phase: 1 pulse/revolution	A, B phase: 32,768 pulses/revolution Z phase: 1 pulse/revolution	A, B phase: 16,384 pulses/revolution Z phase: 1 pulse/revolution	A, B phase: 32,768 pulses/revolution Z phase: 1 pulse/revolution
Maximum rotational speed	-32,768 to +32,767 rotations or 0 to 65,534 rotations			
Power supply voltage	5 V DC±5%			
Power supply current	180 mA			
Applicable battery voltage	3.6 V DC			
Battery current consumption	20 µA (for backup, when stopped), 3 µA (when Servo Driver is powered)			
Maximum rotation speed	5,000 r/min			
Output signals	+S, -S			
Output impedance	Conforming to EIA RS-422A. Output based on LTC1485CS or equivalent.			
Serial communications data	Position data, poll sensor, U, V, W phase, encoder alarm, Servomotor data			
Serial communications method	Bi-directional communications in HDLC format, by Manchester method			
Absolute value communications data	Amount of rotation			

2-6 Cable and Connector Specifications

All dimensions are in millimeters unless otherwise specified.

2-6-1 Control Cables

■ Motion Control Unit Cables (R88A-CPW□M□)

These are special cables for connecting to Motion Control Units used with OMRON Programmable Controllers. There are two types, for one or two axes.

Note The following Motion Control Units are available.

- CS1W-MC221/-MC421(-V1)
- CV-500-MC221/-MC421
- C200H-MC221

● Cable Models

Number of axes	Model	Length (L)	Outer diameter of sheath	Weight
1	R88A-CPW001M1	1 m	8.3 dia.	Approx. 0.2 kg
	R88A-CPW002M1	2 m		Approx. 0.3 kg
	R88A-CPW003M1	3 m		Approx. 0.4 kg
	R88A-CPW005M1	5 m		Approx. 0.6 kg
2	R88A-CPW001M2	1 m	8.3 dia.	Approx. 0.3 kg
	R88A-CPW002M2	2 m		Approx. 0.4 kg
	R88A-CPW003M2	3 m		Approx. 0.5 kg
	R88A-CPW005M2	5 m		Approx. 0.7 kg

● Connection Configuration and External Dimensions

Cables for One Axis

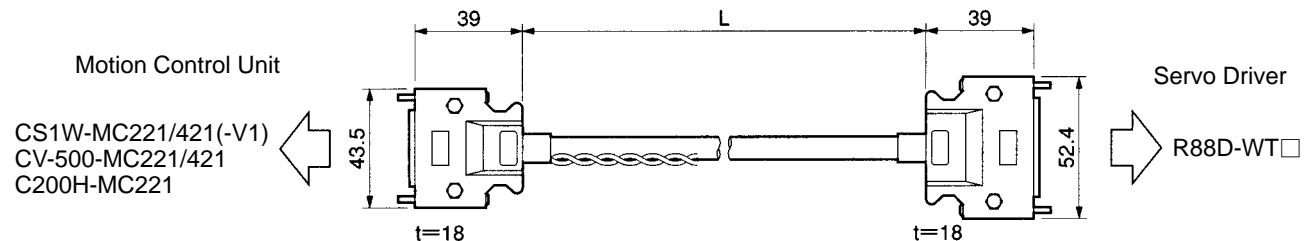

Cables for Two Axes

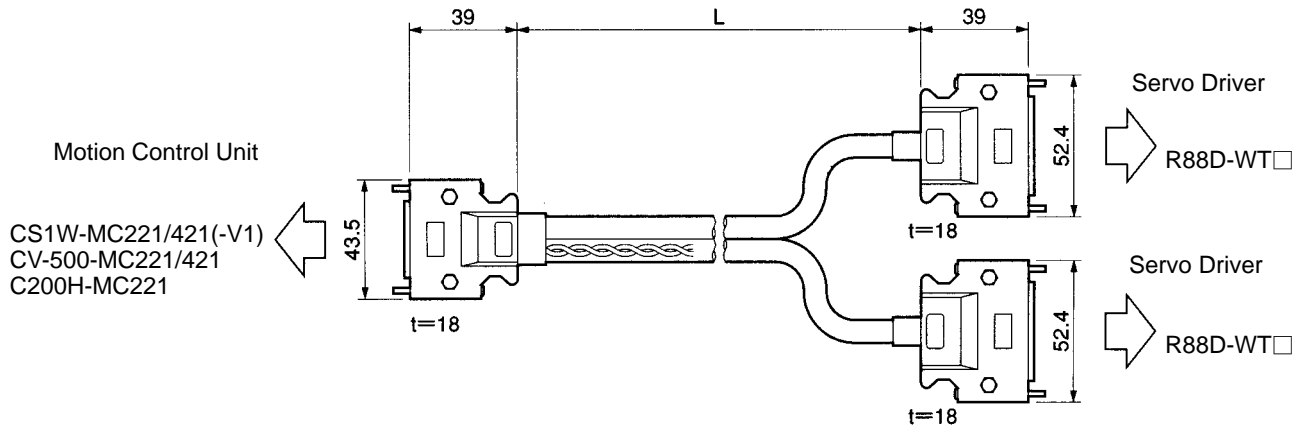

• Wiring

Cables for One Axis

Motion Control Unit

Servo Driver

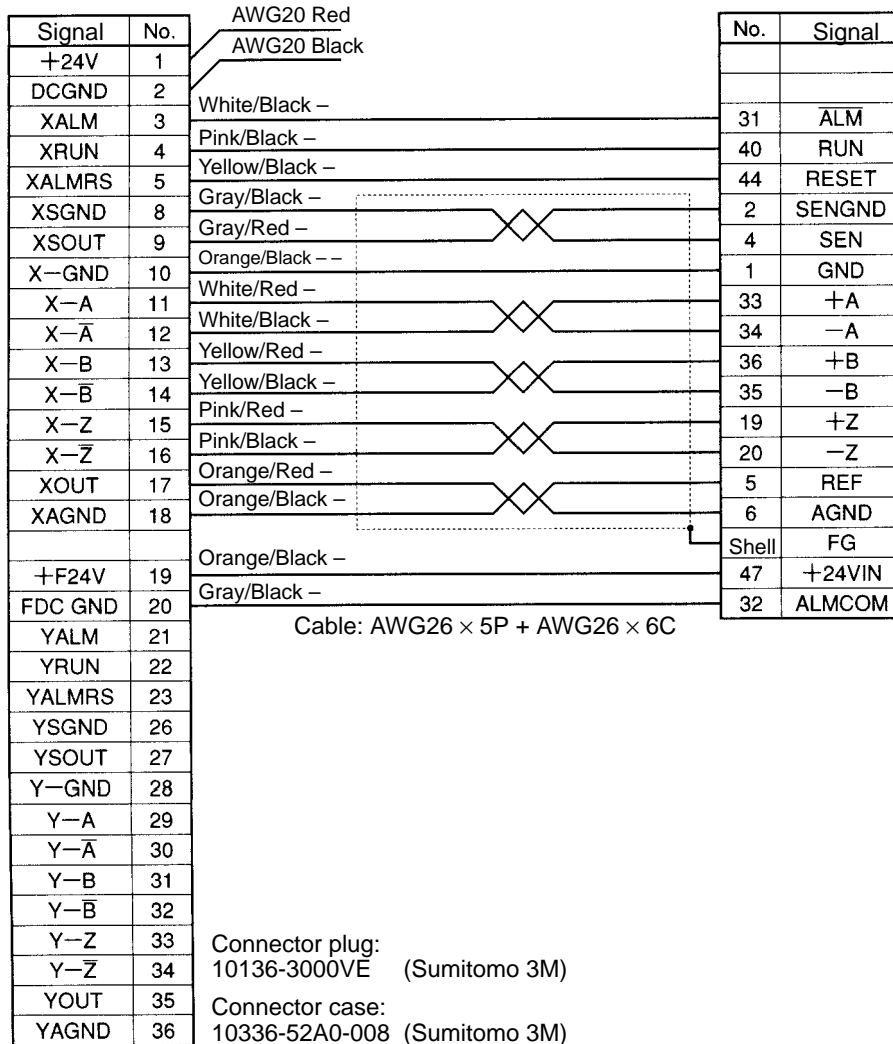

Note 3. Supply 24 V DC to the two wires (black and red) that are taken out from the Controller's connector. (Red is + and black is -.)

■ **General Control Cables (R88A-CPW□S)**

A General Control Cable is connected to the Servo Driver's Control I/O Connector (CN1). There is no connector on the Controller end. When connecting it to a Position Control Unit with no special cable provided, or to a controller manufactured by another company, wire a connector to match the controller.

Note There is one method for connecting to a Controller with no special cable provided, and another method for using connector Terminal Block cable and a connector Terminal Block.

● **Cable Models**

Model	Length (L)	Outer diameter of sheath	Weight
R88A-CPW001S	1 m	12.8 dia.	Approx. 0.3 kg
R88A-CPW002S	2 m		Approx. 0.6 kg

● **Connection Configuration and External Dimensions**

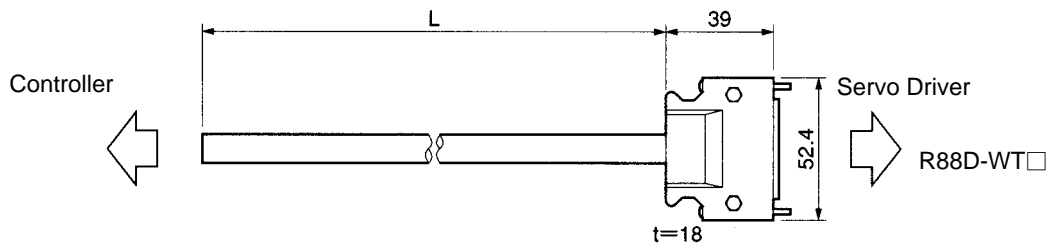

● Wiring

No.	Wire/mark color	Signal name	
		Pulse	Analog
1	Yellow/Black (---)	GND	GND
2	Pink/Black (----)	SENGND	SENGND
3	Yellow/Red (-----)	PCOM	
4	Pink/Red (----)	SEN	SEN
5	Orange/Red (-)		REF
6	Orange/Black (-)		AGND
7	Gray/Red (-)	+CW	
8	Gray/Black (-)	-CW	
9	White/Red (-)		TREF
10	White/Black (-)		AGND
11	Yellow/Red (-)	+CCW	
12	Yellow/Black (-)	-CCW	
13	Yellow/Black (-----)	PCOM	
14	Pink/Black (-)	-ECRST	
15	Pink/Red (-)	+ECRST	
16	Orange/Red (-----)		
17	Orange/Black (-----)		
18	Pink/Red (-----)	PCOM	
19	Gray/Red (-)	+Z	+Z
20	Gray/Black (-)	-Z	-Z
21	Gray/Red (-----)	BAT	BAT
22	Gray/Black (-----)	BATGND	BATGND
23	White/Red (-----)		
24	White/Black (-----)		
25	Orange/Red (-)	INP1	VCMP
26	Orange/Black (-)	INP1COM	VCMPCOM

No.	Wire/mark color	Signal name	
		Pulse	Analog
27	White/Red (-)	TGON	TGON
28	White/Black (-)	TGONCOM	TGONCOM
29	Yellow/Red (-)	READY	READY
30	Yellow/Black (-)	READYCOM	READYCOM
31	Pink/Red (-)	ALM	ALM
32	Pink/Black (-)	ALMCOM	ALMCOM
33	Orange/Red (---)	+A	+A
34	Orange/Black (---)	-A	-A
35	Gray/Black (---)	-B	-B
36	Gray/Red (---)	+B	+B
37	White/Red (---)	ALO1	ALO1
38	White/Black (---)	ALO2	ALO2
39	Yellow/Red (---)	ALO3	ALO3
40	Pink/Red (---)	RUN	RUN
41	Pink/Black (---)	MING	MING
42	Orange/Red (----)	POT	POT
43	Orange/Black (----)	NOT	NOT
44	Gray/Black (----)	RESET	RESET
45	White/Red (----)	PCL	PCL
46	White/Black (----)	NCL	NCL
47	Gray/Red (----)	+24VIN	+24VIN
48	Yellow/Red (----)	+ABS	+ABS
49	Yellow/Black (----)	-ABS	-ABS
50	Pink/Black (-----)		
Shell	-	FG	FG

Connector plug: 10150-3000VE (Sumitomo 3M)
 Connector case: 10350-52A0-008 (Sumitomo 3M)
 Cable: AWG24 × 25P UL20276

Note Wires with the same wire color and the same number of marks form twisted pairs. For example, the orange wire with one red mark (-) is twisted together with the orange wire with one black mark (-).

■ Connector Terminal Block Cables (R88A-CTW□N) and Connector Terminal Blocks (XW2B-50G5)

● Cable Models

Model	Length (L)	Outer diameter of sheath	Weight
R88A-CTW001N	1 m	11.8 dia.	Approx. 0.2 kg
R88A-CTW002N	2 m		Approx. 0.4 kg

● Connection Configuration and External Dimensions

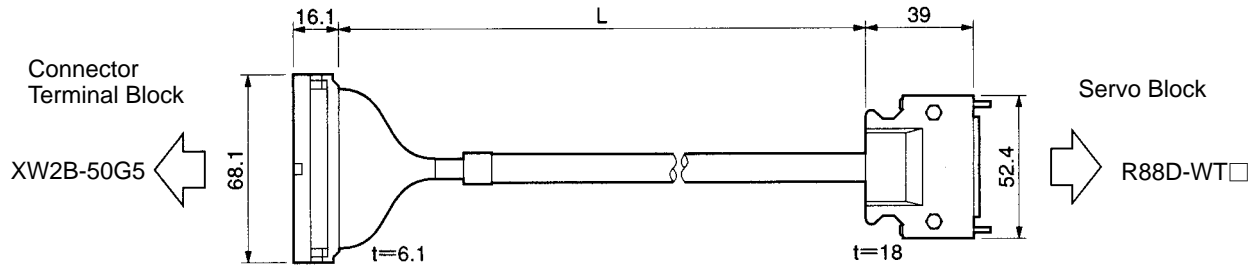

● Wiring

Terminal Block No.	Connector No.	Servo Driver No.	Wire/mark color	Signal	
				Pulse	Analog
1	1	1	Yellow/Black (---)	GND	GND
2	2	2	Pink/Black (----)	SENGND	SENGND
3	3	3	Yellow/Red (-----)	PCOM	
4	4	4	Pink/Red (-----)	SEN	SEN
5	5	5	Orange/Red (-)		REF
6	6	6	Orange/Black (-)		AGND
7	7	7	Gray/Red (-)	+CW	
8	8	8	Gray/Black (-)	-CW	
9	9	9	White/Red (-)		TREF
10	10	10	White/Black (-)		AGND
11	11	11	Yellow/Red (-)	+CCW	
12	12	12	Yellow/Black (-)	-CCW	
13	13	13	Yellow/Black (-----)	PCOM	
14	14	14	Pink/Black (-)	-ECRST	
15	15	15	Pink/Red (-)	+ECRST	
16	16	16	Orange/Red (-----)		
17	17	17	Orange/Black (-----)		
18	18	18	Pink/Red (-----)	PCOM	
19	19	19	Gray/Red (---)	+Z	+Z
20	20	20	Gray/Black (---)	-Z	-Z
21	21	21	Gray/Red (-----)	BAT	BAT
22	22	22	Gray/Black (-----)	BATGND	BATGND
23	23	23	White/Red (-----)		
24	24	24	White/Black (-----)		
25	25	25	Orange/Red (---)	INP1	VCMP
26	26	26	Orange/Black (---)	INP1COM	VCMPCOM
27	27	27	White/Red (---)	TGON	TGON
28	28	28	White/Black (---)	TGONCOM	TGONCOM
29	29	29	Yellow/Red (---)	READY	READY
30	30	30	Yellow/Black (---)	READYCOM	READYCOM
31	31	31	Pink/Red (---)	ALM	ALM
32	32	32	Pink/Black (---)	ALMCOM	ALMCOM
33	33	33	Orange/Red (---)	+A	+A
34	34	34	Orange/Black (---)	-A	-A
35	35	35	Gray/Black (---)	-B	-B
36	36	36	Gray/Red (---)	+B	+B
37	37	37	White/Red (---)	ALO1	ALO1
38	38	38	White/Black (---)	ALO2	ALO2
39	39	39	Yellow/Red (---)	ALO3	ALO3
40	40	40	Pink/Red (---)	RUN	RUN
41	41	41	Pink/Black (---)	MING	MING
42	42	42	Orange/Red (-----)	POT	POT
43	43	43	Orange/Black (-----)	NOT	NOT
44	44	44	Gray/Black (-----)	RESET	RESET
45	45	45	White/Red (-----)	PCL	PCL
46	46	46	White/Black (-----)	NCL	NCL
47	47	47	Gray/Red (-----)	+24VIN	+24VIN
48	48	48	Yellow/Red (-----)	+ABS	+ABS
49	49	49	Yellow/Black (-----)	-ABS	-ABS
50	50	50	Pink/Black (-----)		
		Shell	-	FG	FG

Note Wires with the same wire color and the same number of marks form twisted pairs. For example, the orange wire with one red mark (-) is twisted together with the orange wire with one black mark (-).

Servo Driver Connector

Connector plug:
10150-3000VE (Sumitomo 3M)

Connector case:
10350-52A0-008 (Sumitomo 3M)

Terminal Block Connector

Connector socket:
XG4M-5030 (OMRON)

Strain relief:
XG4T-5004 (OMRON)

Cable: AWG28 × 25P UL2464

■ Connector Terminal Block Cables (XW2Z-□J-B15) and Connector Terminal Blocks (XW2B-20G□)

Of the control I/O signals (CN1), only those related to positioning control are connected to a Terminal Block. Use a Connector Terminal Block to save wiring work when using the W-series Servo Driver with the FNY-NS115 MECHATROLINK-II Interface Unit attached to it. This also saves more wiring space than when using an XW2B-50G5 Connector Terminal Block.

Connector Terminal Block Cables (XW2Z-□J-B15)

● Cables

XW2Z-□J-B15

Model	Length (L)	External sheath diameter	Weight
XW2Z-100J-B15	1 m	8.0 dia.	Approx. 0.1 kg
XW2Z-200J-B15	2 m		Approx. 0.2 kg

● Connection Configuration and External Dimensions

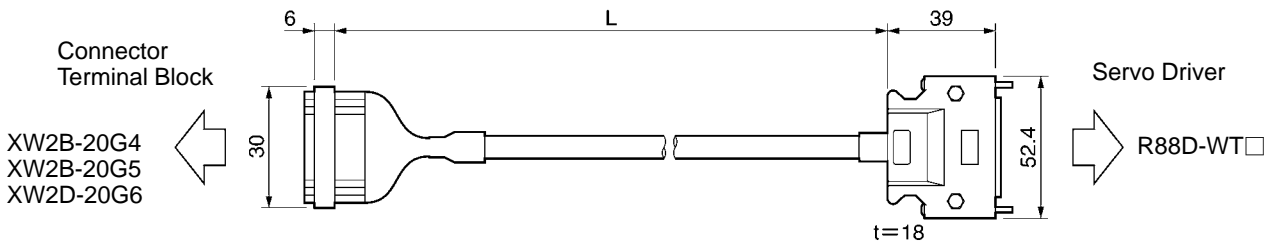

● Wiring

Connector Terminal Block

Servo Driver

No.	No.	Symbol
1	47	+24VIN
2		
3		
4		
5		
6		
7		
8	41*	DEC
9	42*	POT
10	43*	NOT
11	44*	EXT1
12	45*	EXT2
13	46*	EXT3
14	22	BATGND
15	21	BAT
16	28*	BKIRCOM
17	27*	BKIR
18	32	ALMCOM
19	31	ALM
20	Shell	FG

Note Functions can be allocated by the user to pin numbers with asterisks. Allocate functions to suit your application.

Servo Driver Connector

Connector plug:
10150-3000VE (Sumitomo 3M)
Connector case:
10350-52A0-008 (Sumitomo 3M)

Terminal Block Connector

Connector socket:
XG4M-2030 (OMRON)
Strain relief:
XG4T-2004 (OMRON)

Cable

AWG28 × 3P+AWG28 × 7C UL2464

■ Connector Terminal Blocks (XW2B-20G□)

Three models of Connector Terminal Block are available. Select an appropriate model depending on wiring methods and screw sizes.

● Terminal Blocks

XW2B-20G4

The XW2B-20G4 is an M3 screw terminal block.

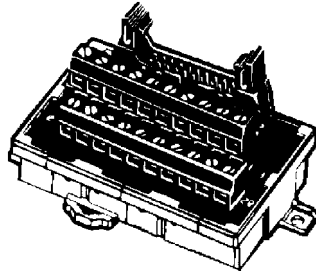

● External Dimensions

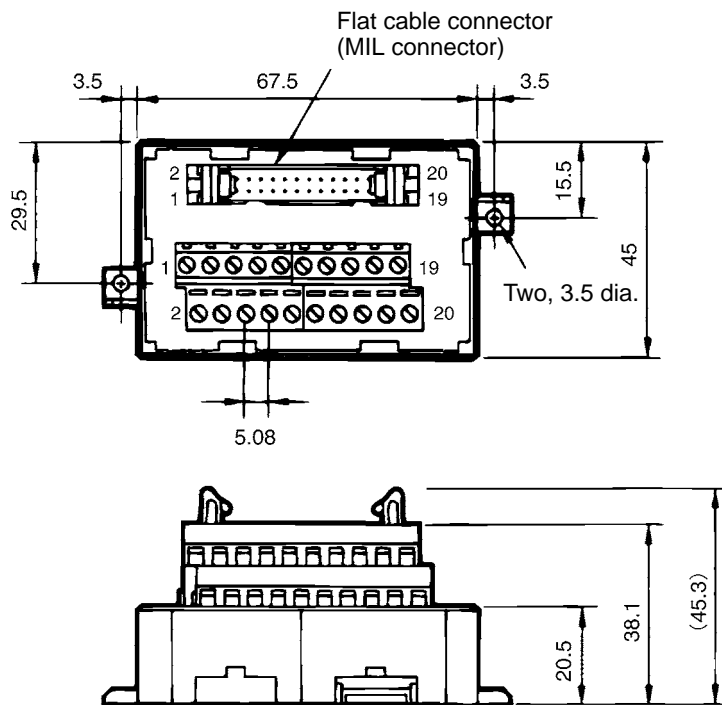

Note The terminal pitch is 5.08 mm.

Precautions

- Use 0.30 to 1.25 mm² wire (AWG22 to AWG16).
- The wire inlet for M3 screw terminal blocks is 1.8 × 2.5 mm (vertical × horizontal).

- Strip the sheath as shown in the following diagram.

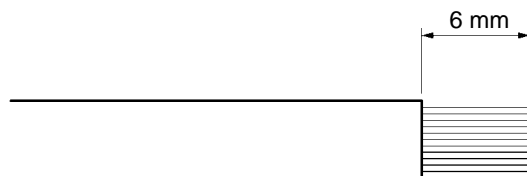

• Terminal Blocks

XW2B-20G5

The XW2B-20G5 is an M3.5 screw terminal block.

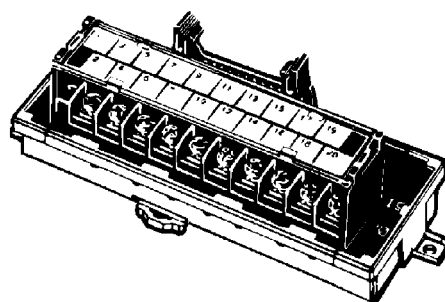

• External Dimensions

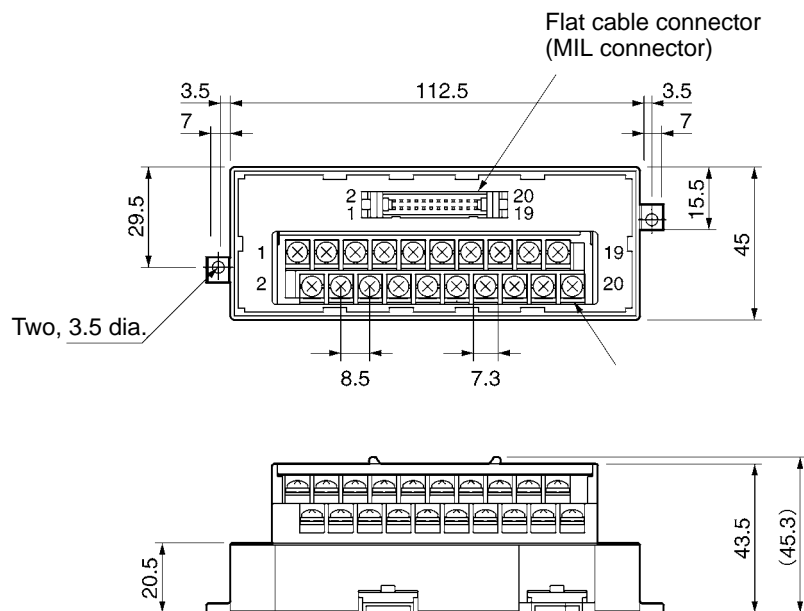

Note The terminal pitch is 8.5 mm.

Precautions

- When using crimp terminals, use crimp terminals with the following dimensions.

Round Crimp Terminals

Fork Crimp Terminals

Dia: 3.7 mm

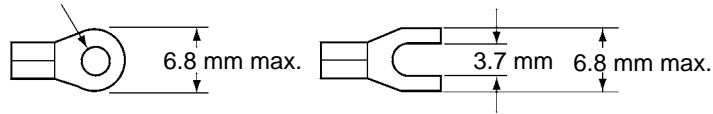

Applicable Crimp Terminals		Applicable Wires
Round Terminals	2 to 3.5	AWG16 to AWG14 (1.25 to 2.0 mm ²)
Fork Terminals	2Y to 3.5	AWG16 to AWG14 (1.25 to 2.0 mm ²)

• Terminal Blocks

XW2D-20G6

The XW2D-20G6 is an M3 screw terminal block.

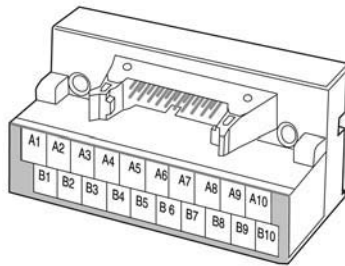

• External Dimensions

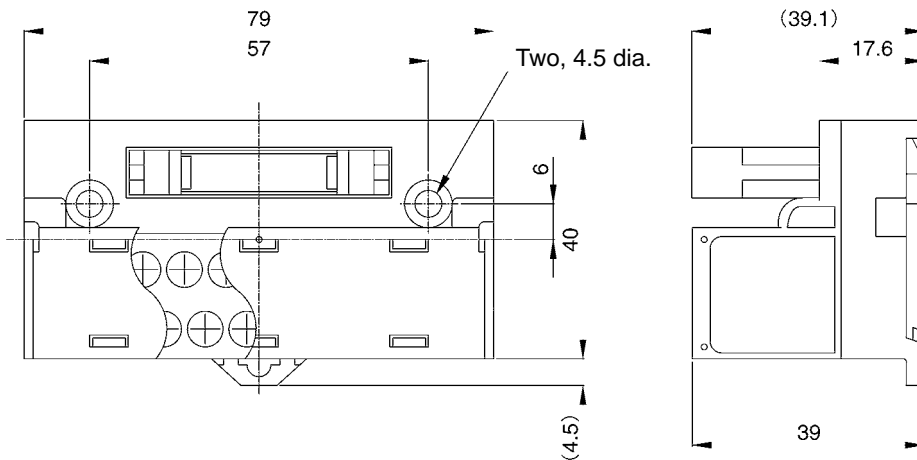

Precautions

- When using crimp terminals, use crimp terminals with the following dimensions.

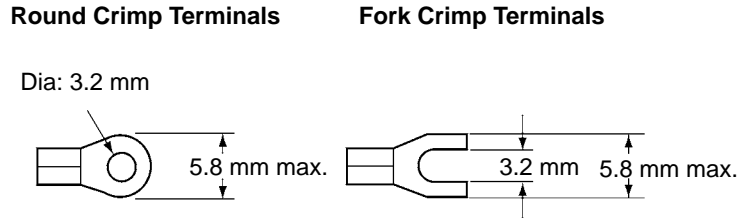

Applicable Crimp Terminals		Applicable Wires
Round Terminals	1.25 to 3	AWG22 to AWG16 (0.30 to 1.25 mm ²)
Fork Terminals	1.25Y to 3	AWG22 to AWG16 (0.30 to 1.25 mm ²)

• Terminal Block Wiring Example (for XW2B-20G4/XW2B-20G5 and XW2D-20G6)

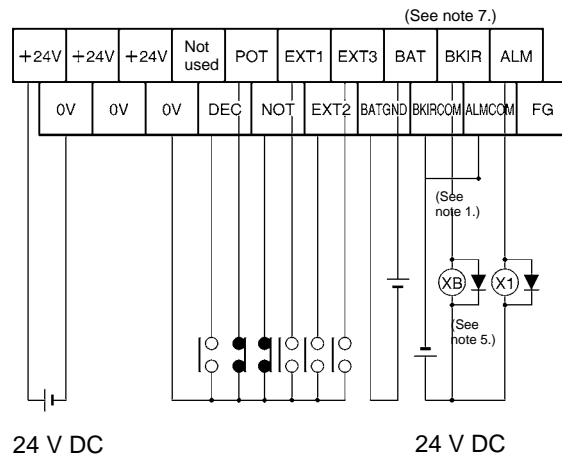

- Note 1.** Backup battery for absolute encoders (2.8 to 4.5 V).
- Note 2.** A backup battery for absolute encoders is not required for motors with incremental encoders.
- Note 3.** Connect a backup battery for an absolute encoder to either the Connector-Terminal Block Conversion Unit or to the battery cable for absolute encoder backup (with battery), but not to both.
- Note 4.** Secure the backup battery for an absolute encoder with cable clips with double-sided tape or a similar means.
- Note 5.** The XB contact is used to turn the electromagnetic brake ON and OFF.
- Note 6.** Do not wire unused terminals.

Note 7. Use the Terminal Block only after allocating Servo Driver signals to pins. The following parameters are set when wiring as described in the above wiring example.

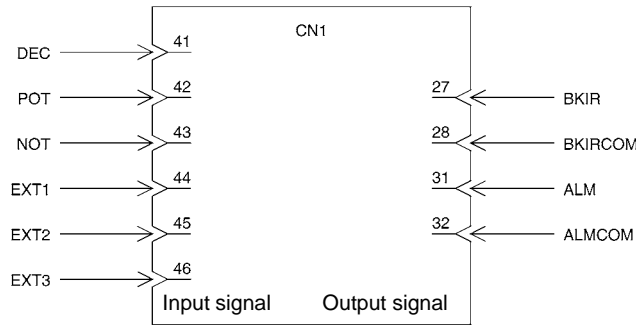

I/O Signal (CN1) Parameter Settings

Parameter No.	Name	Setting
Pn50A	Input Signal Selection 1	2881
Pn50B	Input Signal Selection 2	8883
Pn511	Input Signal Selection 5	6541
Pn50F	Output Signal Selection 2	0200

2-6-2 Motor Cable Specifications

The motor cable is used to connect the Servo Driver and Servomotor. Select the appropriate cable for the Servomotor. The maximum distance between Servo Driver and Servomotor is 50 m.

Note Use a Robot Cable if the cable needs to bend.

● Bend Resistance of Robot Cables

Robot Cables use wire that has a bending life of 20 million times when used at the minimum bending radius (R) or greater under the following conditions.

- Note 1.** The bending resistance data was compiled under test conditions and must be used as a guide only. An extra margin must always be allowed.
- Note 2.** The life expectancy is the number of uses without cracks or damage to the sheath that would affect performance while current is applied to the wire conductor. This value does not apply to cut shield strands.
- Note 3.** If Robot Cables are used at a bending radius smaller than the minimum bending radius, mechanical malfunctions, ground faults, and other problems may occur due to insulation breakdown. Contact your OMRON representative if you need to use a Robot Cable with a bending radius smaller than the minimum bending radius.

● Power Cables

	Model	Minimum bending radius (R)
Without brake	R88A-CAWA□□□SR	55 mm
With brake	R88A-CAWA□□□BR	55 mm
Without brake	R88A-CAWB□□□SR	96 mm
With brake	R88A-CAWB□□□BR	96 mm
Without brake	R88A-CAWC□□□SR	96 mm
With brake	R88A-CAWC□□□BR	96 mm
Without brake	R88A-CAWD□□□SR	150 mm
With brake	R88A-CAWD□□□BR	150 mm

□□□: 003 to 050

● Encoder Cables

Model	Minimum bending radius (R)
R88A-CAWA□□□CR	46 mm
R88A-CAWA△△△CR	78 mm
R88A-CAWB□□□NR	46 mm
R88A-CAWB△△△NR	78 mm

□□□: 003 to 020

△△△: 030 to 050

● Moving Bending Test

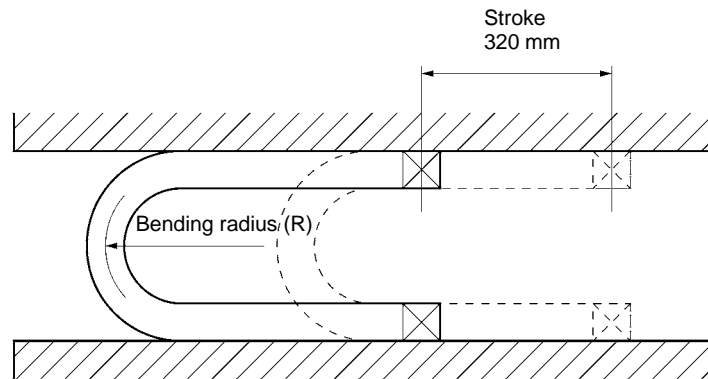

Standard Encoder Cable Specifications

Select an Encoder Cable to match the Servomotor being used. The cables range in length from 3 to 50 meters. (The maximum distance between the Servomotor and Servo Driver is 50 meters.)

■ **Cable Models**

R88A-CRWA□C

Model	Length (L)	Outer diameter of sheath	Weight
R88A-CRWA003C	3 m	6.5 dia.	Approx. 0.2 kg
R88A-CRWA005C	5 m		Approx. 0.4 kg
R88A-CRWA010C	10 m		Approx. 0.7 kg
R88A-CRWA015C	15 m		Approx. 1.0 kg
R88A-CRWA020C	20 m		Approx. 1.3 kg
R88A-CRWA030C	30 m	6.8 dia.	Approx. 2.5 kg
R88A-CRWA040C	40 m		Approx. 3.3 kg
R88A-CRWA050C	50 m		Approx. 4.1 kg

R88A-CRWB□N

Model	Length (L)	Outer diameter of sheath	Weight
R88A-CRWB003N	3 m	6.5 dia.	Approx. 0.4 kg
R88A-CRWB005N	5 m		Approx. 0.5 kg
R88A-CRWB010N	10 m		Approx. 0.8 kg
R88A-CRWB015N	15 m		Approx. 1.1 kg
R88A-CRWB020N	20 m		Approx. 1.4 kg
R88A-CRWB030N	30 m	6.8 dia.	Approx. 2.6 kg
R88A-CRWB040N	40 m		Approx. 3.4 kg
R88A-CRWB050N	50 m		Approx. 4.2 kg

■ **Connection Configuration and External Dimensions**

R88A-CRWA□C

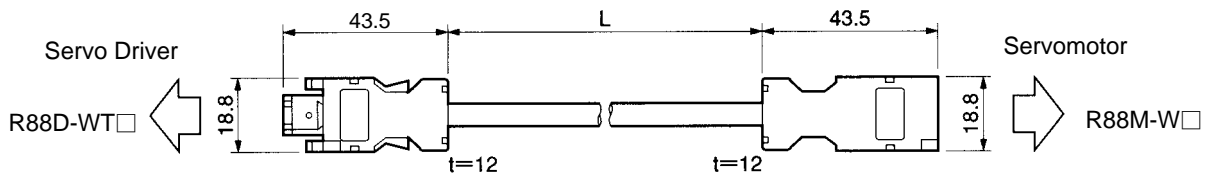

R88A-CRWB□N

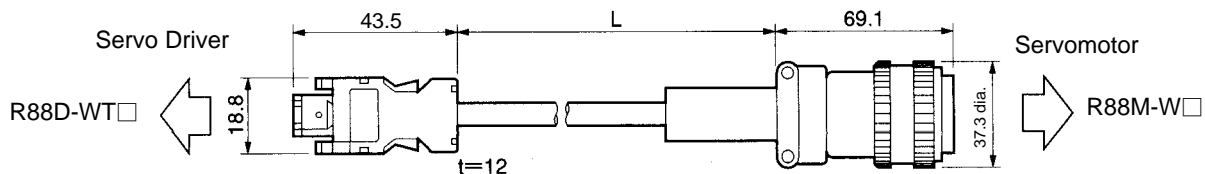

■ Wiring

R88A-CRWA□C

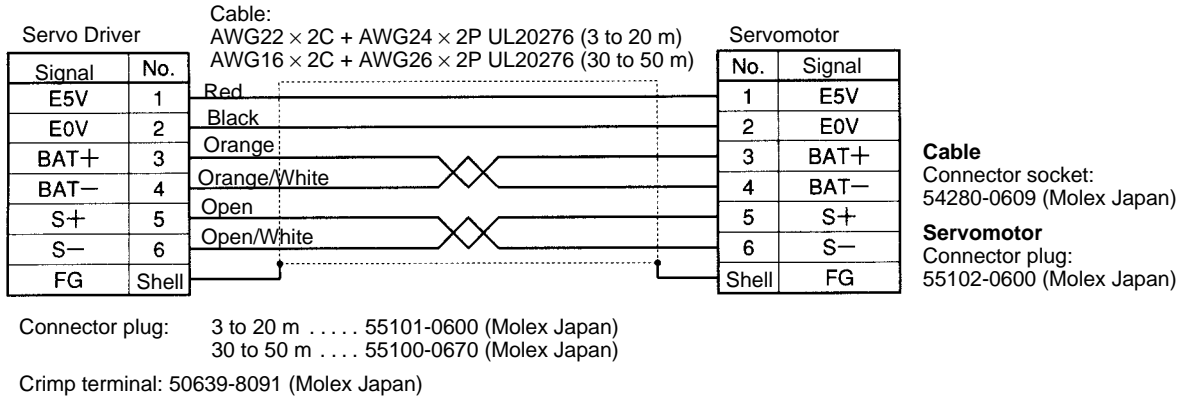

R88A-CRWB□N

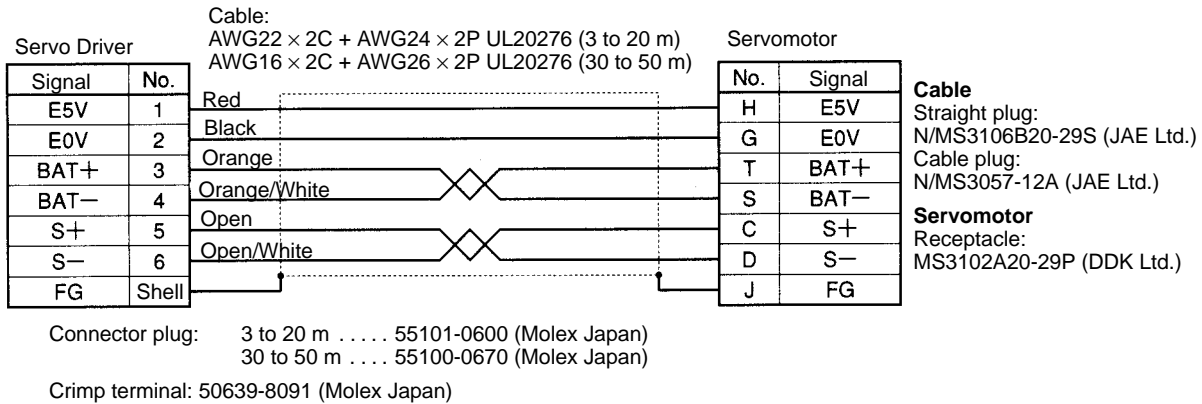

Power Cable

Select a Power Cable to match the Servomotor being used. The cables range in length from 3 to 50 meters. (The maximum distance between the Servomotor and Servo Driver is 50 meters.)

■ R88A-CAWA□

The R88A-CAWA□ Cables are for 3,000-r/min Servomotors (30 to 750 W) and 3,000-r/min Flat-style Servomotors (100 to 750 W).

● Cable Models

For Servomotors without Brakes

Model	Length (L)	Outer diameter of sheath	Weight
R88A-CAWA003S	3 m	6.2 dia.	Approx. 0.2 kg
R88A-CAWA005S	5 m		Approx. 0.3 kg
R88A-CAWA010S	10 m		Approx. 0.6 kg
R88A-CAWA015S	15 m		Approx. 0.9 kg
R88A-CAWA020S	20 m		Approx. 1.2 kg
R88A-CAWA030S	30 m		Approx. 1.8 kg
R88A-CAWA040S	40 m		Approx. 2.4 kg
R88A-CAWA050S	50 m		Approx. 3.0 kg

For Servomotors with Brakes

Model	Length (L)	Outer diameter of sheath	Weight
R88A-CAWA003B	3 m	7.4 dia.	Approx. 0.3 kg
R88A-CAWA005B	5 m		Approx. 0.5 kg
R88A-CAWA010B	10 m		Approx. 0.9 kg
R88A-CAWA015B	15 m		Approx. 1.3 kg
R88A-CAWA020B	20 m		Approx. 1.7 kg
R88A-CAWA030B	30 m		Approx. 2.5 kg
R88A-CAWA040B	40 m		Approx. 3.3 kg
R88A-CAWA050B	50 m		Approx. 4.1 kg

Note If a 750-W Servomotor is to be wired at a distance of 30 meters or more, use R88A-CAWB□□ Cable.

• Connection Configuration and External Dimensions

For Servomotors without Brakes

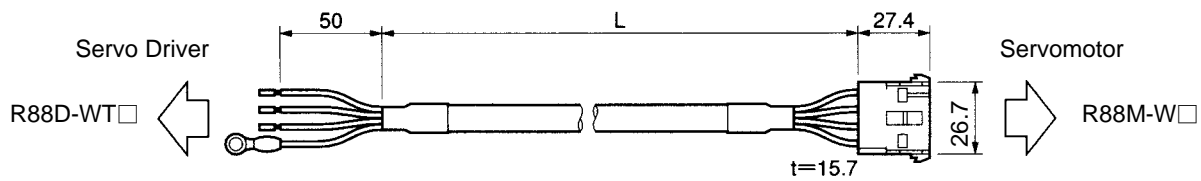

For Servomotors with Brakes

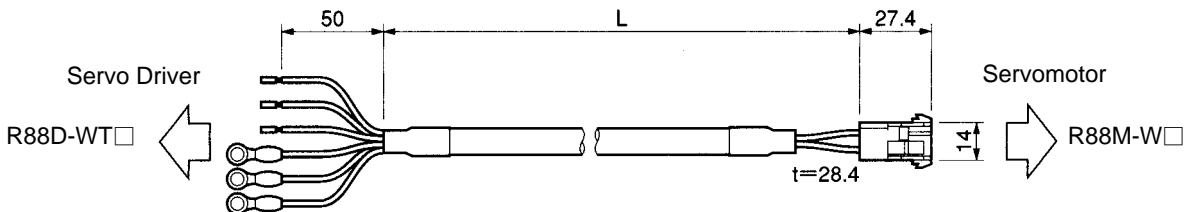

• Wiring

For Servomotors without Brakes

<p>Servo Driver</p> <p>Red</p> <p>White</p> <p>Blue</p> <p>Green/Yellow</p> <p>M4 crimp terminal</p>	<p>Cable: AWG20 × 4C UL2464</p>	<table border="1"> <thead> <tr> <th>No.</th> <th>Symbol</th> </tr> </thead> <tbody> <tr> <td>1</td> <td>Phase-U</td> </tr> <tr> <td>2</td> <td>Phase-V</td> </tr> <tr> <td>3</td> <td>Phase-W</td> </tr> <tr> <td>4</td> <td>FG</td> </tr> </tbody> </table>	No.	Symbol	1	Phase-U	2	Phase-V	3	Phase-W	4	FG	<p>Cable</p> <p>Connector cap: 350780-1 (Tyco Electronics AMP KK)</p> <p>Connector socket: 350689-3 (Tyco Electronics AMP KK)</p> <p>Servomotor</p> <p>Connector plug: 350779-1 (Tyco Electronics AMP KK)</p> <p>Connector pins 1 to 3: 350690-3 (Tyco Electronics AMP KK)</p> <p>Connector pin 4: 770210-1 (Tyco Electronics AMP KK)</p>
No.	Symbol												
1	Phase-U												
2	Phase-V												
3	Phase-W												
4	FG												

For Servomotors with Brakes

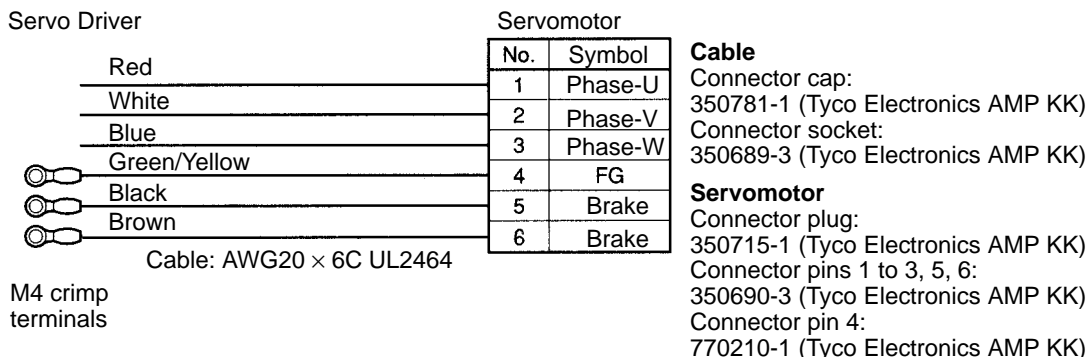

■ **R88A-CAWB□**

The R88A-CAWB□ Cables are for 3,000-r/min Flat-style Servomotors (1.5 kW).

● **Cable Models**

For Servomotors without Brakes

Model	Length (L)	Outer diameter of sheath	Weight
R88A-CAWB003S	3 m	10.4 dia.	Approx. 0.6 kg
R88A-CAWB005S	5 m		Approx. 1.0 kg
R88A-CAWB010S	10 m		Approx. 1.9 kg
R88A-CAWB015S	15 m		Approx. 2.8 kg
R88A-CAWB020S	20 m		Approx. 3.7 kg
R88A-CAWB030S	30 m		Approx. 5.5 kg
R88A-CAWB040S	40 m		Approx. 7.3 kg
R88A-CAWB050S	50 m		Approx. 9.2 kg

For Servomotors with Brakes

Model	Length (L)	Outer diameter of sheath	Weight
R88A-CAWB003B	3 m	14.5 dia.	Approx. 1.0 kg
R88A-CAWB005B	5 m		Approx. 1.6 kg
R88A-CAWB010B	10 m		Approx. 3.2 kg
R88A-CAWB015B	15 m		Approx. 4.8 kg
R88A-CAWB020B	20 m		Approx. 6.4 kg
R88A-CAWB030B	30 m		Approx. 9.5 kg
R88A-CAWB040B	40 m		Approx. 12.7 kg
R88A-CAWB050B	50 m		Approx. 15.8 kg

Note Use these cables if a 750-W Servomotor is to be wired at a distance of 30 meters or more.

• Connection Configuration and External Dimensions

For Servomotors without Brakes

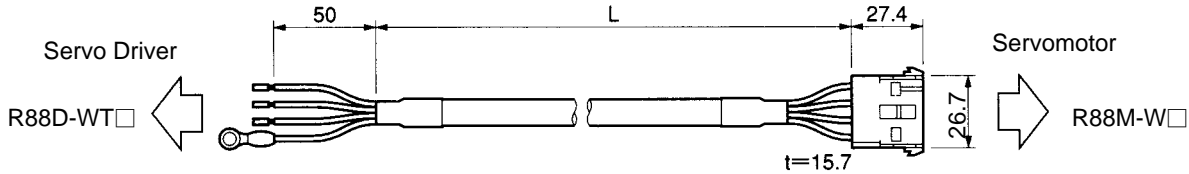

For Servomotors with Brakes

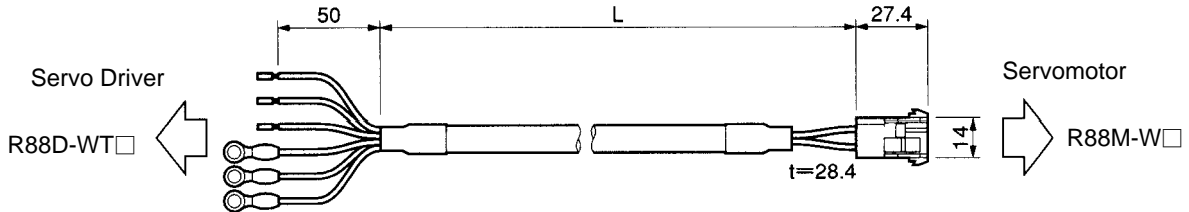

• Wiring

For Servomotors without Brakes

Servo Driver

Red

White

Blue

Green/Yellow

M4 crimp terminal

Cable: AWG14 × 4C UL2463

Servomotor	
No.	Symbol
1	Phase-U
2	Phase-V
3	Phase-W
4	FG

Cable
 Connector cap:
 350780-1 (Tyco Electronics AMP KK)
 Connector socket:
 Pins 1 to 3:
 350551-6 (Tyco Electronics AMP KK)
 Pin 4:
 350551-3 (Tyco Electronics AMP KK)

Servomotor
 Connector plug:
 350779-1 (Tyco Electronics AMP KK)
 Connector pins 1 to 3:
 350547-6 (Tyco Electronics AMP KK)
 Connector pin 4:
 350669-1 (Tyco Electronics AMP KK)

For Servomotors with Brakes

Servo Drivers

Red

White

Blue

Green/Yellow

Black

Brown

M4 crimp terminals

Cable: AWG14 × 6C UL2463

Servomotors	
No.	Symbol
1	Phase-U
2	Phase-V
3	Phase-W
4	FG
5	Brake
6	Brake

Cable
 Connector plug:
 350781-1 (Tyco Electronics AMP KK)
 Connector socket:
 Pins 1 to 3:
 350551-6 (Tyco Electronics AMP KK)
 Pins 4 to 6:
 350551-3 (Tyco Electronics AMP KK)

Servomotor
 Connector plug:
 350715-1 (Tyco Electronics AMP KK)
 Connector pins 1 to 3:
 350547-6 (Tyco Electronics AMP KK)
 Connector pin 4:
 350669-1 (Tyco Electronics AMP KK)
 Connector pins 5 and 6:
 350690-3 (Tyco Electronics AMP KK)

■ **R88A-CAWC□**

The R88A-CAWC□ Cables are for 3,000-r/min Servomotors (1 to 2 kW), 1,000-r/min Servomotors (300 to 900 W), and 1,500-r/min Servomotors (450 W to 1.3 kW).

● **Cable Models**

For Servomotors without Brakes

Model	Length (L)	Outer diameter of sheath	Weight
R88A-CAWC003S	3 m	10.4 dia.	Approx. 0.6 kg
R88A-CAWC005S	5 m		Approx. 1.0 kg
R88A-CAWC010S	10 m		Approx. 1.9 kg
R88A-CAWC015S	15 m		Approx. 2.8 kg
R88A-CAWC020S	20 m		Approx. 3.7 kg
R88A-CAWC030S	30 m		Approx. 5.6 kg
R88A-CAWC040S	40 m		Approx. 7.4 kg
R88A-CAWC050S	50 m		Approx. 9.2 kg

For Servomotors with Brakes

Model	Length (L)	Outer diameter of sheath	Weight
R88A-CAWC003B	3 m	14.5 dia.	Approx. 1.1 kg
R88A-CAWC005B	5 m		Approx. 1.7 kg
R88A-CAWC010B	10 m		Approx. 3.3 kg
R88A-CAWC015B	15 m		Approx. 4.9 kg
R88A-CAWC020B	20 m		Approx. 6.4 kg
R88A-CAWC030B	30 m		Approx. 9.6 kg
R88A-CAWC040B	40 m		Approx. 12.7 kg
R88A-CAWC050B	50 m		Approx. 15.9 kg

● **Connection Configuration and External Dimensions**

For Servomotors without Brakes

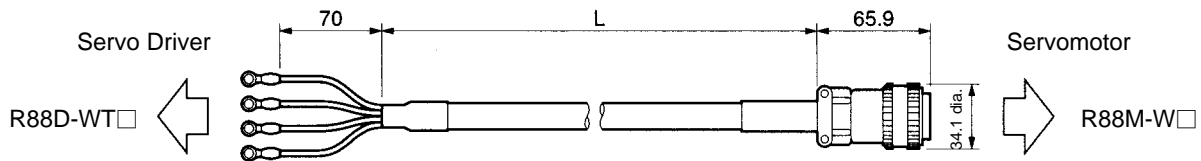

For Servomotors with Brakes

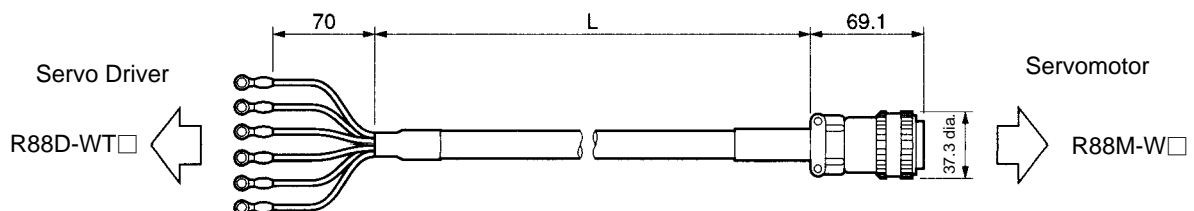

• Wiring

For Servomotors without Brakes

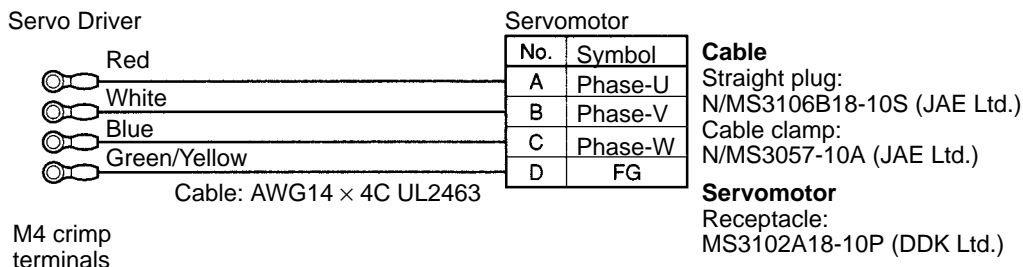

For Servomotors with Brakes

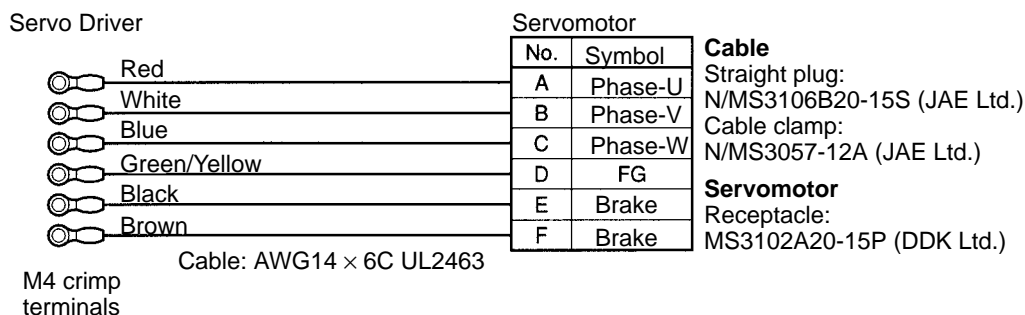

Note Connector-type terminal blocks are used for Servo Drivers of 1.5 kW or less, as shown in *Terminal Block Wiring Procedure* under *3-2-3 Terminal Block Wiring*. Remove the crimp terminals from the phase-U, phase-V, and phase-W wires for these Servo Drivers.

■ **R88A-CAWD**□

The R88A-CAWD□ Cables are for 3,000-r/min Servomotors (3 to 5 kW), 1,000-r/min Servomotors (1.2 to 3 kW), and 1,500-r/min Servomotors (1.8 to 4.4 kW).

• Cable Models

For Servomotors without Brakes

Model	Length (L)	Outer diameter of sheath	Weight
R88A-CAWD003S	3 m	14.7 dia.	Approx. 1.3 kg
R88A-CAWD005S	5 m		Approx. 2.1 kg
R88A-CAWD010S	10 m		Approx. 4.1 kg
R88A-CAWD015S	15 m		Approx. 6.0 kg
R88A-CAWD020S	20 m		Approx. 8.0 kg
R88A-CAWD030S	30 m		Approx. 11.9 kg
R88A-CAWD040S	40 m		Approx. 15.8 kg
R88A-CAWD050S	50 m		Approx. 19.7 kg

For Servomotors with Brakes

Model	Length (L)	Outer diameter of sheath	Weight
R88A-CAWD003B	3 m	17.8 dia.	Approx. 1.9 kg
R88A-CAWD005B	5 m		Approx. 3.0 kg
R88A-CAWD010B	10 m		Approx. 5.8 kg
R88A-CAWD015B	15 m		Approx. 8.6 kg
R88A-CAWD020B	20 m		Approx. 11.4 kg
R88A-CAWD030B	30 m		Approx. 17.0 kg
R88A-CAWD040B	40 m		Approx. 22.6 kg
R88A-CAWD050B	50 m		Approx. 28.2 kg

• Connection Configuration and External Dimensions

For Servomotors without Brakes

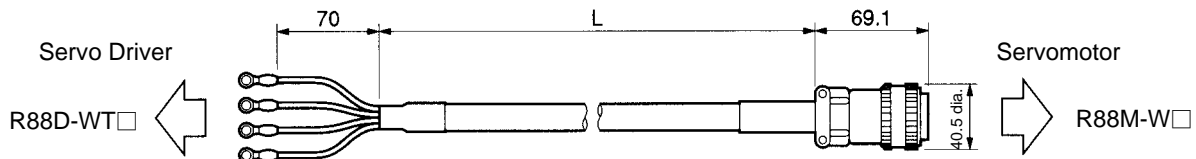

For Servomotors with Brakes

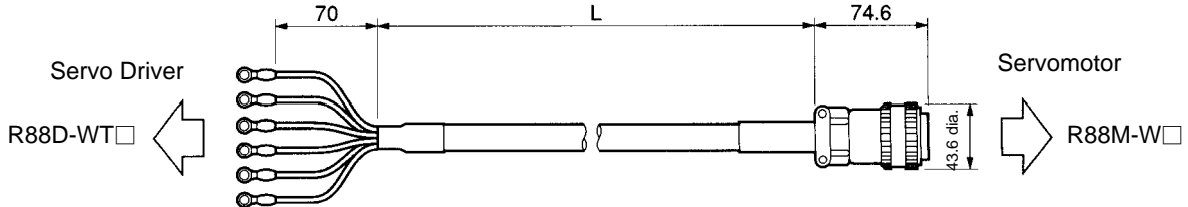

• Wiring

For Servomotors without Brakes

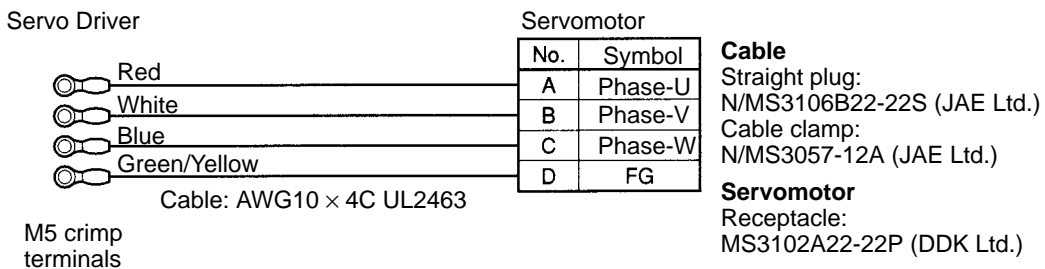

For Servomotors with Brakes

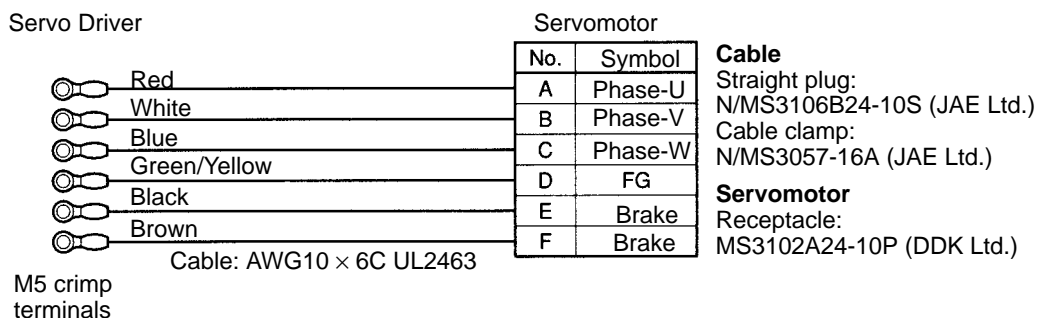

Note Connector-type terminal blocks are used for Servo Drivers of 1.5 kW or less, as shown in *Terminal Block Wiring Procedure* under *3-2-3 Terminal Block Wiring*. Remove the crimp terminals from the phase-U, phase-V, and phase-W wires for these Servo Drivers.

When using a 1.2-kW motor (1,000 r/min), it cannot be connected to the R88D-WT15H connector as is. Wires with ferrules must be thinned. Remove the crimp terminals from the phase-U, phase-V, and phase-W wires on the Servo Driver side and thin the conductor to approximately half or use a pin terminal.

■ **R88A-CAWE□**

The R88A-CAWE□ Cables are for 1,000-r/min Servomotors (4 kW) and 1,500-r/min Servomotors (5.5 kW).

● **Cable Models**

For Servomotors without Brakes

Model	Length (L)	Outer diameter of sheath	Weight
R88A-CAWE003S	3 m	23.8 dia.	Approx. 2.8 kg
R88A-CAWE005S	5 m		Approx. 4.5 kg
R88A-CAWE010S	10 m		Approx. 8.6 kg
R88A-CAWE015S	15 m		Approx. 12.8 kg
R88A-CAWE020S	20 m		Approx. 16.9 kg
R88A-CAWE030S	30 m		Approx. 25.2 kg
R88A-CAWE040S	40 m		Approx. 33.5 kg
R88A-CAWE050S	50 m		Approx. 41.8 kg

For Servomotors with Brakes

Model	Length (L)	Outer diameter of sheath	Weight
R88A-CAWE003B	3 m	5.4 dia.	Approx. 0.1 kg
R88A-CAWE005B	5 m		Approx. 0.2 kg
R88A-CAWE010B	10 m		Approx. 0.4 kg
R88A-CAWE015B	15 m		Approx. 0.6 kg
R88A-CAWE020B	20 m		Approx. 0.8 kg
R88A-CAWE030B	30 m		Approx. 1.2 kg
R88A-CAWE040B	40 m		Approx. 1.6 kg
R88A-CAWE050B	50 m		Approx. 2.0 kg

Note For 4-kW (1,000-r/min) Servomotors and 5.5-kW (1,500-r/min) Servomotors, there are separate connectors for power and brakes. Therefore, whenever a Servomotor with a brake is used, it is necessary to use both Power Cable for Servomotors without brakes (R88A-CAWE□S) and Power Cable for Servomotors with brakes (R88A-CAWE□B). R88A-CAWE□B Cable is used for wiring (2-core) the brake line only.

• Connection Configuration and External Dimensions

For Power Connector

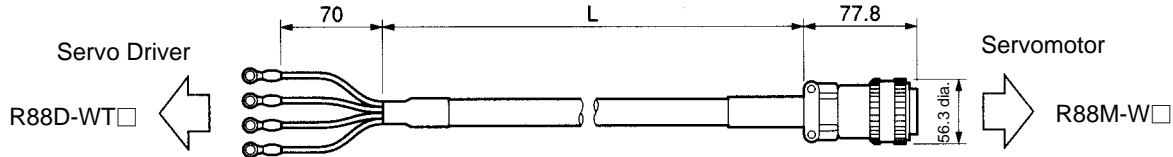

For Brake Connector

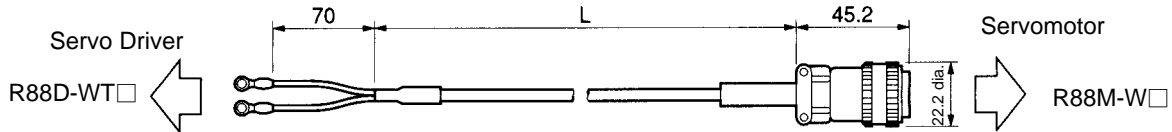

• Wiring

For Power Connector

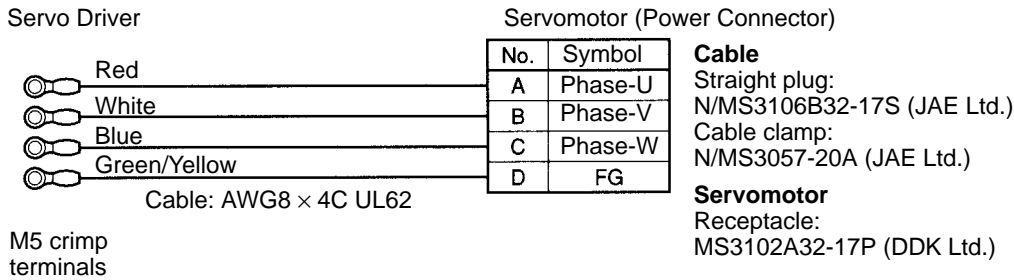

For Brake Connector

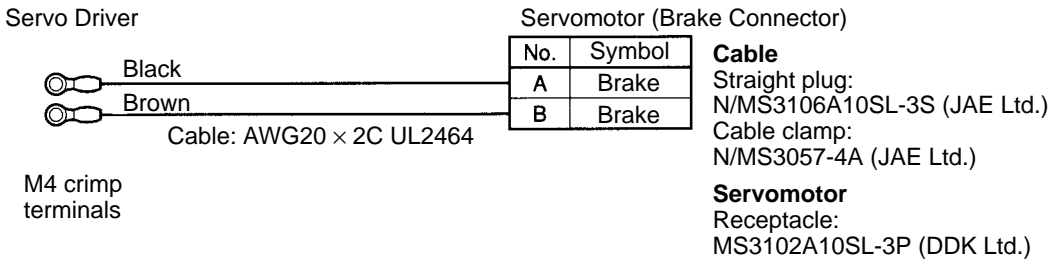

■ R88A-CAWF□

The R88A-CAWF□ Cables are for 1,000-r/min Servomotors (5.5 kW) and 1,500-r/min Servomotors (7.5 to 11 kW).

• Cable Models

For Servomotors without Brakes

Model	Length (L)	Outer diameter of sheath	Weight
R88A-CAWF003S	3 m	28.5 dia.	Approx. 4.0 kg
R88A-CAWF005S	5 m		Approx. 6.5 kg
R88A-CAWF010S	10 m		Approx. 12.6 kg
R88A-CAWF015S	15 m		Approx. 18.8 kg
R88A-CAWF020S	20 m		Approx. 24.9 kg
R88A-CAWF030S	30 m		Approx. 37.2 kg
R88A-CAWF040S	40 m		Approx. 49.5 kg
R88A-CAWF050S	50 m		Approx. 61.8 kg

For Servomotors with Brakes

To the Servomotor’s brake connector, connect R88A-CAWE□B Cable, just as for 4-kW (1,000-r/min) Servomotors with brakes. Refer to the previous page for R88A-CAWE□B specifications.

Note For 5.5-kW (1,000-r/min) Servomotors, and 7.5- to 11-kW (1,500-r/min) Servomotors, there are separate connectors for power and brakes. Therefore, whenever a Servomotor with a brake is used, it is necessary to use both Power Cable for Servomotors without brakes (R88A-CAWF□S) and Power Cable for Servomotors with brakes (R88A-CAWE□B). R88A-CAWE□B Cable is used for wiring (2-core) the brake line only.

• Connection Configuration and External Dimensions

(For Power Connector)

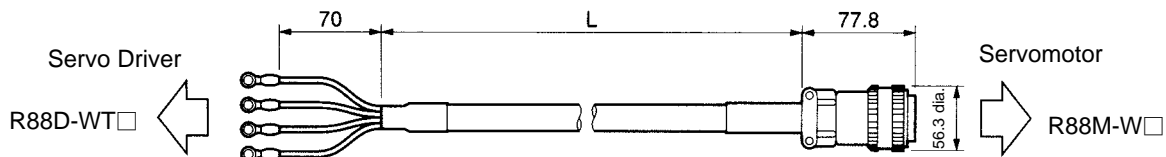

• Wiring (for Power Connector)

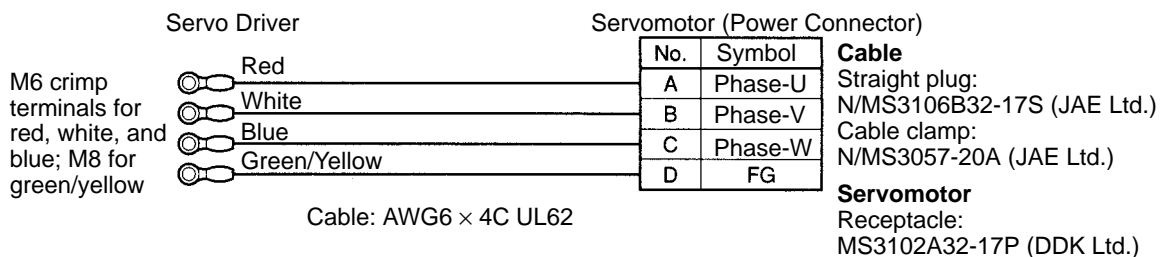

Robot Cable Encoder Cable Specifications

Select an Encoder Cable to match the Servomotor being used. The cables range in length from 3 to 50 meters. (The maximum distance between the Servomotor and Servo Driver is 50 meters.)

• Cable Models

R88A-CRWA□CR

Model	Length (L)	Outer diameter of sheath	Weight
R88A-CRWA003CR	3 m	7.0 dia.	Approx. 0.2 kg
R88A-CRWA005CR	5 m		Approx. 0.3 kg
R88A-CRWA010CR	10 m		Approx. 0.6 kg
R88A-CRWA015CR	15 m		Approx. 0.9 kg
R88A-CRWA020CR	20 m		Approx. 1.2 kg
R88A-CRWA030CR	30 m	6.7 dia.	Approx. 1.8 kg
R88A-CRWA040CR	40 m		Approx. 2.4 kg
R88A-CRWA050CR	50 m		Approx. 3.0 kg

R88A-CRWB□NR

Model	Length (L)	Outer diameter of sheath	Weight
R88A-CRWB003NR	3 m	7.0 dia.	Approx. 0.3 kg
R88A-CRWB005NR	5 m		Approx. 0.4 kg
R88A-CRWB010NR	10 m		Approx. 0.7 kg
R88A-CRWB015NR	15 m		Approx. 1.0 kg
R88A-CRWB020NR	20 m		Approx. 1.3 kg
R88A-CRWB030NR	30 m	6.7 dia.	Approx. 1.9 kg
R88A-CRWB040NR	40 m		Approx. 2.5 kg
R88A-CRWB050NR	50 m		Approx. 3.1 kg

• Connection Configuration and External Dimensions

R88A-CRWA□CR

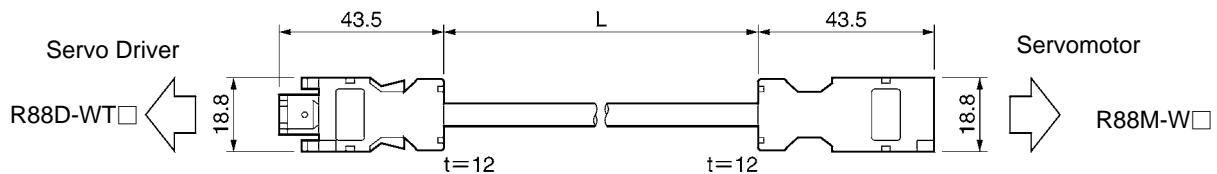

R88A-CRWB□NR

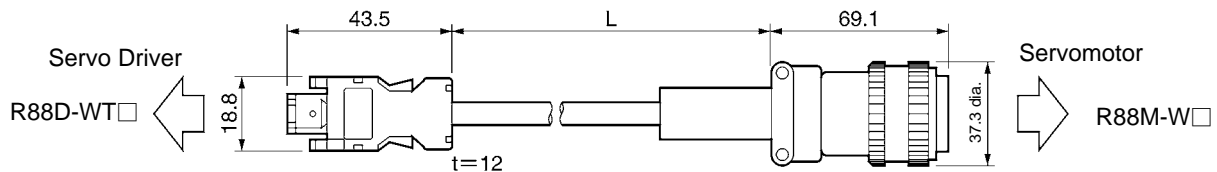

• Wiring

R88A-CRWA□CR

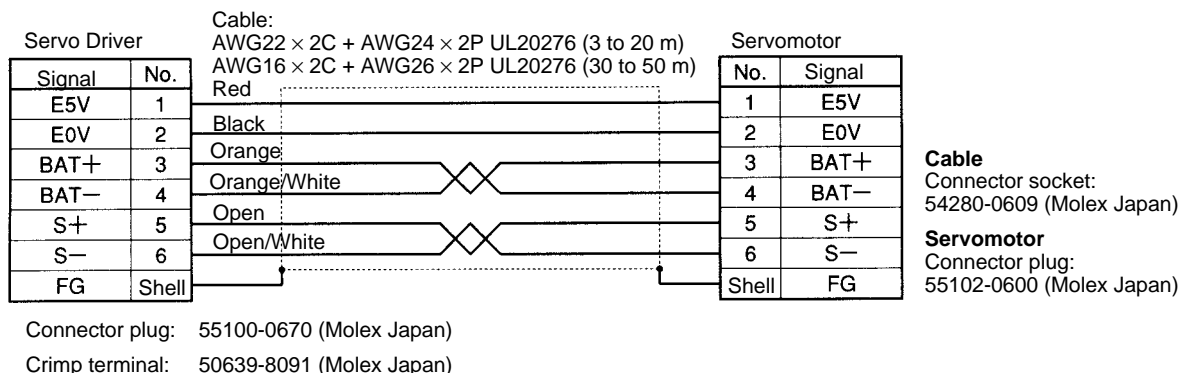

R88A-CRWB□NR

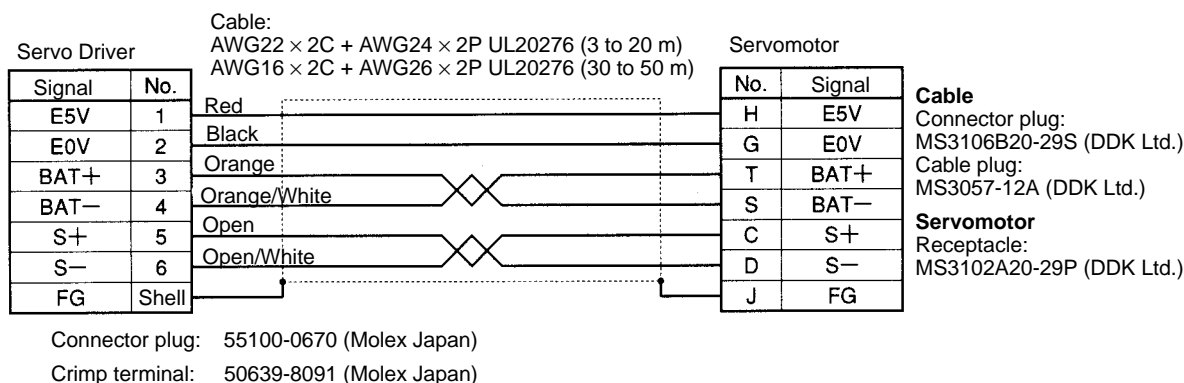

Robot Cable Power Cable Specifications

Select a Power Cable to match the Servomotor being used. The cables range in length from 3 to 50 meters. (The maximum distance between the Servomotor and Servo Driver is 50 meters.)

■ **R88A-CAWA□R**

The R88A-CAWA□R Cables are for 3,000-r/min Servomotors (30 to 750 W) and 3,000-r/min Flat-style Servomotors (100 to 750 W).

• Cable Models

For Servomotors without Brakes

Model	Length (L)	Outer diameter of sheath	Weight
R88A-CAWA003SR	3 m	6.5 dia.	Approx. 0.2 kg
R88A-CAWA005SR	5 m		Approx. 0.3 kg
R88A-CAWA010SR	10 m		Approx. 0.6 kg
R88A-CAWA015SR	15 m		Approx. 0.8 kg
R88A-CAWA020SR	20 m		Approx. 1.1 kg
R88A-CAWA030SR	30 m		Approx. 1.7 kg
R88A-CAWA040SR	40 m		Approx. 2.2 kg
R88A-CAWA050SR	50 m		Approx. 2.8 kg

For Servomotors with Brakes

Model	Length (L)	Outer diameter of sheath	Weight
R88A-CAWA003BR	3 m	7.0 dia.	Approx. 0.2 kg
R88A-CAWA005BR	5 m		Approx. 0.4 kg
R88A-CAWA010BR	10 m		Approx. 0.8 kg
R88A-CAWA015BR	15 m		Approx. 1.1 kg
R88A-CAWA020BR	20 m		Approx. 1.5 kg
R88A-CAWA030BR	30 m		Approx. 2.3 kg
R88A-CAWA040BR	40 m		Approx. 3.0 kg
R88A-CAWA050BR	50 m		Approx. 3.8 kg

Note If a 750-W Servomotor is to be wired at a distance of 30 meters or more, use R88A-CAWB□R Cable.

• **Connection Configuration and External Dimensions**

For Servomotors without Brakes

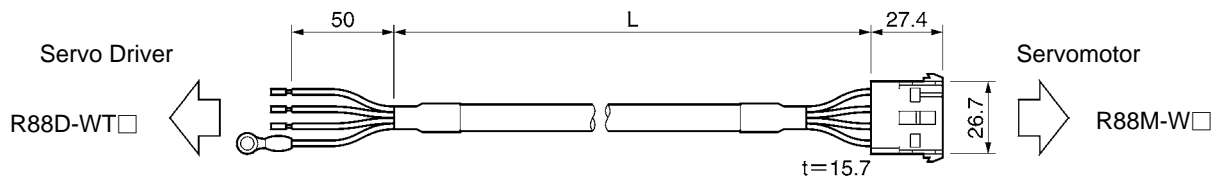

For Servomotors with Brakes

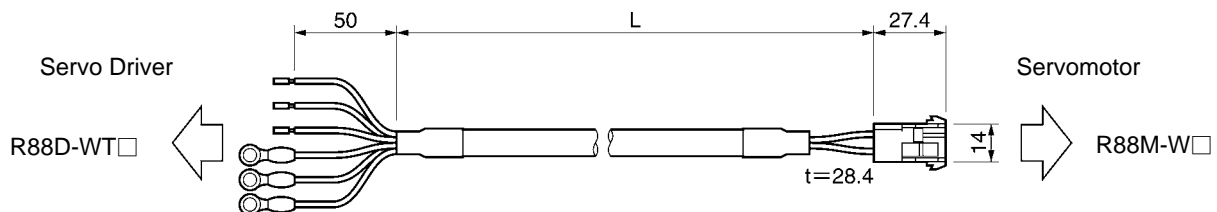

• **Wiring**

For Servomotors without Brakes

<p>Servo Driver</p> <p>Red</p> <p>White</p> <p>Blue</p> <p>Green/Yellow</p> <p>M4 crimp terminal</p> <p>Cable: AWG21 × 4C UL2464</p>	<table border="1"> <thead> <tr> <th>No.</th> <th>Symbol</th> </tr> </thead> <tbody> <tr> <td>1</td> <td>Phase-U</td> </tr> <tr> <td>2</td> <td>Phase-V</td> </tr> <tr> <td>3</td> <td>Phase-W</td> </tr> <tr> <td>4</td> <td>FG</td> </tr> </tbody> </table>	No.	Symbol	1	Phase-U	2	Phase-V	3	Phase-W	4	FG	<p>Servomotor</p> <p>Cable</p> <p>Connector cap: 350780-1 (Tyco Electronics AMP KK)</p> <p>Connector socket: 350689-3 (Tyco Electronics AMP KK)</p> <p>Servomotor</p> <p>Connector plug: 350779-1 (Tyco Electronics AMP KK)</p> <p>Connector pins 1 to 3: 350690-3 (Tyco Electronics AMP KK)</p> <p>Connector pin 4: 770210-1 (Tyco Electronics AMP KK)</p>
No.	Symbol											
1	Phase-U											
2	Phase-V											
3	Phase-W											
4	FG											

For Servomotors with Brakes

Servo Drivers

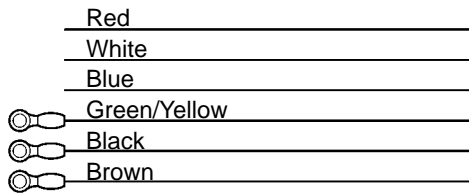

M4 crimp terminals

Cable: AWG21 × 6C UL2464

Servomotors

No.	Symbol
1	Phase-U
2	Phase-V
3	Phase-W
4	FG
5	Brake
6	Brake

Cable

Connector cap:
350781-1 (Tyco Electronics AMP KK)
Connector socket:
350689-3 (Tyco Electronics AMP KK)

Servomotor

Connector plug:
350715-1 (Tyco Electronics AMP KK)
Connector pins 1 to 3:
350690-3 (Tyco Electronics AMP KK)
Connector pin 4:
770210-1 (Tyco Electronics AMP KK)
Connector pins 5 and 6:
350690-3 (Tyco Electronics AMP KK)

■ **R88A-CAWB□R**

The R88A-CAWB□R Cables are for 3,000-r/min Flat-style Servomotors (1.5 kW).

● **Cable Models**

For Servomotors without Brakes

Model	Length (L)	Outer diameter of sheath	Weight
R88A-CAWB003SR	3 m	9.5 dia.	Approx. 0.5 kg
R88A-CAWB005SR	5 m		Approx. 0.8 kg
R88A-CAWB010SR	10 m		Approx. 1.5 kg
R88A-CAWB015SR	15 m		Approx. 2.2 kg
R88A-CAWB020SR	20 m		Approx. 3.0 kg
R88A-CAWB030SR	30 m		Approx. 4.5 kg
R88A-CAWB040SR	40 m		Approx. 5.9 kg
R88A-CAWB050SR	50 m		Approx. 7.4 kg

For Servomotors with Brakes

Model	Length (L)	Outer diameter of sheath	Weight
R88A-CAWB003BR	3 m	11.5 dia.	Approx. 0.7 kg
R88A-CAWB005BR	5 m		Approx. 1.1 kg
R88A-CAWB010BR	10 m		Approx. 2.2 kg
R88A-CAWB015BR	15 m		Approx. 3.3 kg
R88A-CAWB020BR	20 m		Approx. 4.4 kg
R88A-CAWB030BR	30 m		Approx. 6.6 kg
R88A-CAWB040BR	40 m		Approx. 8.8 kg
R88A-CAWB050BR	50 m		Approx. 11.0 kg

Note Use these cables if a 750-W Servomotor is to be wired at a distance of 30 meters or more.

• Connection Configuration and External Dimensions

For Servomotors without Brakes

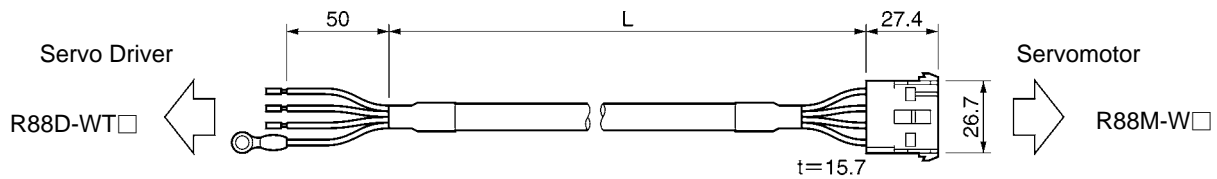

For Servomotors with Brakes

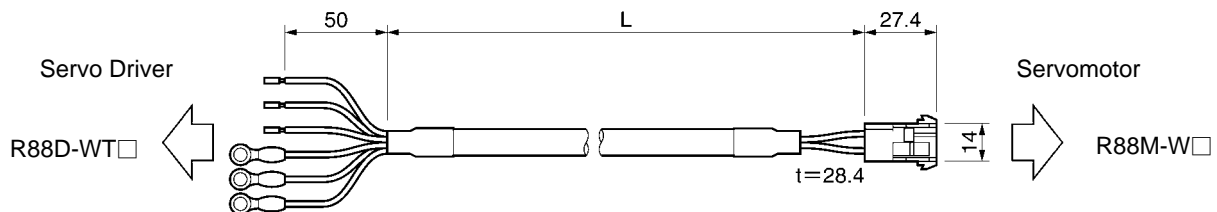

• Wiring

For Servomotors without Brakes

<p>Servo Driver</p> <p>Red</p> <p>White</p> <p>Blue</p> <p>Green/Yellow</p> <p>M4 crimp terminal</p>	<p>Cable: AWG15 × 4C UL2586</p>	<table border="1"> <thead> <tr> <th colspan="2">Servomotor</th> </tr> <tr> <th>No.</th> <th>Symbol</th> </tr> </thead> <tbody> <tr> <td>1</td> <td>Phase-U</td> </tr> <tr> <td>2</td> <td>Phase-V</td> </tr> <tr> <td>3</td> <td>Phase-W</td> </tr> <tr> <td>4</td> <td>FG</td> </tr> </tbody> </table>	Servomotor		No.	Symbol	1	Phase-U	2	Phase-V	3	Phase-W	4	FG	<p>Cable</p> <p>Connector cap: 350780-1 (Tyco Electronics AMP KK)</p> <p>Connector socket: Pins 1 to 3: 350550-6 (Tyco Electronics AMP KK)</p> <p>Pin 4: 350551-3 (Tyco Electronics AMP KK)</p> <p>Servomotor</p> <p>Connector plug: 350779-1 (Tyco Electronics AMP KK)</p> <p>Connector pins 1 to 3: 350547-6 (Tyco Electronics AMP KK)</p> <p>Connector pin 4: 350669-1 (Tyco Electronics AMP KK)</p>
Servomotor															
No.	Symbol														
1	Phase-U														
2	Phase-V														
3	Phase-W														
4	FG														

For Servomotors with Brakes

Servo Drivers

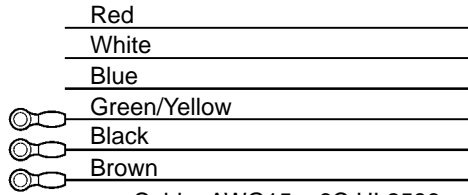

M4 crimp terminals

Servomotors

No.	Symbol
1	Phase-U
2	Phase-V
3	Phase-W
4	FG
5	Brake
6	Brake

Cable

Connector cap:
350781-1 (Tyco Electronics AMP KK)
Connector socket:
Pins 1 to 3:
350550-6 (Tyco Electronics AMP KK)
Pins 4 to 6:
350550-3 (Tyco Electronics AMP KK)

Servomotor

Connector plug:
350715-1 (Tyco Electronics AMP KK)
Connector pins 1 to 3:
350547-6 (Tyco Electronics AMP KK)
Connector pin 4:
350669-1 (Tyco Electronics AMP KK)
Connector pins 5 and 6:
350690-3 (Tyco Electronics AMP KK)

■ **R88A-CAWC□R**

The R88A-CAWC□R Cables are for 3,000-r/min Servomotors (1 to 2 kW), 1,000-r/min Servomotors (300 to 900 W), and 1,500-r/min Servomotors (450 W to 1.3 kW).

● **Cable Models**

For Servomotors without Brakes

Model	Length (L)	Outer diameter of sheath	Weight
R88A-CAWC003SR	3 m	9.5 dia.	Approx. 0.6 kg
R88A-CAWC005SR	5 m		Approx. 0.9 kg
R88A-CAWC010SR	10 m		Approx. 1.6 kg
R88A-CAWC015SR	15 m		Approx. 2.4 kg
R88A-CAWC020SR	20 m		Approx. 3.1 kg
R88A-CAWC030SR	30 m		Approx. 4.6 kg
R88A-CAWC040SR	40 m		Approx. 6.1 kg
R88A-CAWC050SR	50 m		Approx. 7.5 kg

For Servomotors with Brakes

Model	Length (L)	Outer diameter of sheath	Weight
R88A-CAWC003BR	3 m	11.5 dia.	Approx. 0.8 kg
R88A-CAWC005BR	5 m		Approx. 1.3 kg
R88A-CAWC010BR	10 m		Approx. 2.4 kg
R88A-CAWC015BR	15 m		Approx. 3.5 kg
R88A-CAWC020BR	20 m		Approx. 4.6 kg
R88A-CAWC030BR	30 m		Approx. 6.8 kg
R88A-CAWC040BR	40 m		Approx. 9.0 kg
R88A-CAWC050BR	50 m		Approx. 11.2 kg

• Connection Configuration and External Dimensions

For Servomotors without Brakes

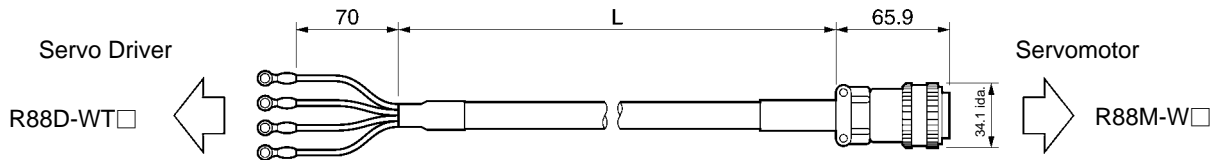

For Servomotors with Brakes

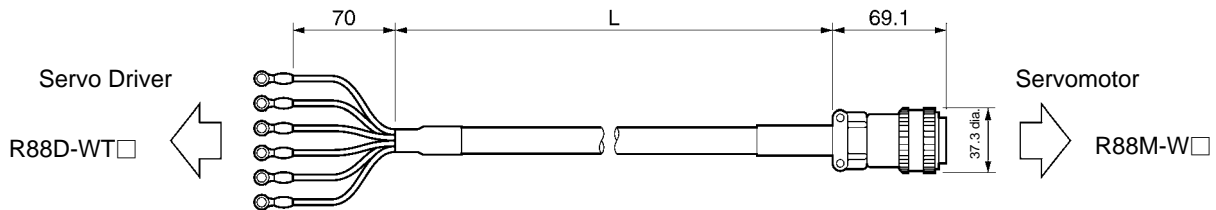

• Wiring

For Servomotors without Brakes

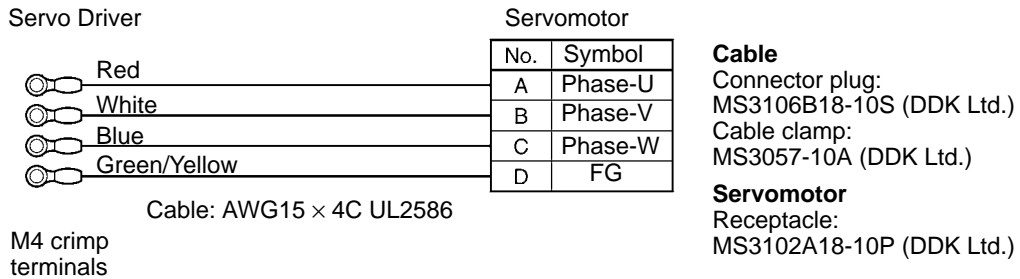

For Servomotors with Brakes

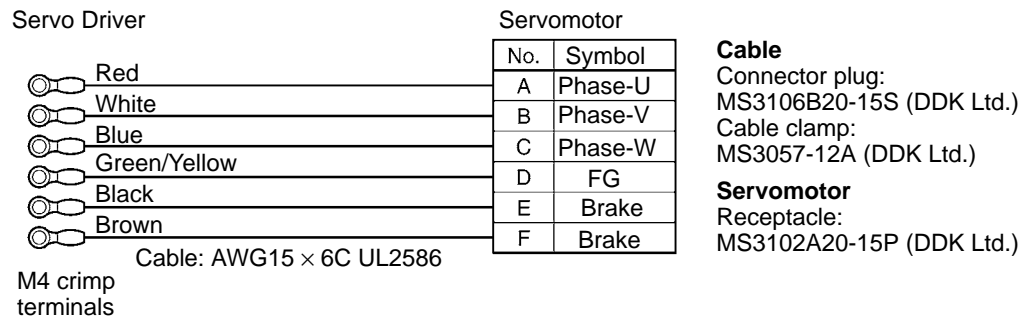

Note Connector-type terminal blocks are used for Servo Drivers of 1.5 kW or less, as shown in Terminal Block Wiring Procedure under 3-2-3 Terminal Block Wiring. Remove the crimp terminals from the phase-U, phase-V, and phase-W wires for these Servo Drivers.

■ R88A-CAWD□R

The R88A-CAWD□R Cables are for 3,000-r/min Servomotors (3 to 5 kW), 1,000-r/min Servomotors (1.2 to 3 kW), and 1,500-r/min Servomotors (1.8 to 4.4 kW).

● Cable Models

For Servomotors without Brakes

Model	Length (L)	Outer diameter of sheath	Weight
R88A-CAWD003SR	3 m	13.5 dia.	Approx. 1.1 kg
R88A-CAWD005SR	5 m		Approx. 1.7 kg
R88A-CAWD010SR	10 m		Approx. 3.3 kg
R88A-CAWD015SR	15 m		Approx. 4.9 kg
R88A-CAWD020SR	20 m		Approx. 6.4 kg
R88A-CAWD030SR	30 m		Approx. 9.5 kg
R88A-CAWD040SR	40 m		Approx. 12.6 kg
R88A-CAWD050SR	50 m		Approx. 15.7 kg

For Servomotors with Brakes

Model	Length (L)	Outer diameter of sheath	Weight
R88A-CAWD003BR	3 m	16.5 dia.	Approx. 1.7 kg
R88A-CAWD005BR	5 m		Approx. 2.6 kg
R88A-CAWD010BR	10 m		Approx. 4.9 kg
R88A-CAWD015BR	15 m		Approx. 7.2 kg
R88A-CAWD020BR	20 m		Approx. 9.4 kg
R88A-CAWD030BR	30 m		Approx. 14.1 kg
R88A-CAWD040BR	40 m		Approx. 18.7 kg
R88A-CAWD050BR	50 m		Approx. 23.3 kg

● Connection Configuration and External Dimensions

For Servomotors without Brakes

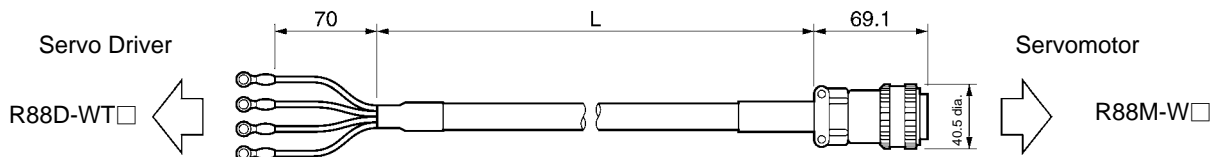

For Servomotors with Brakes

● Wiring

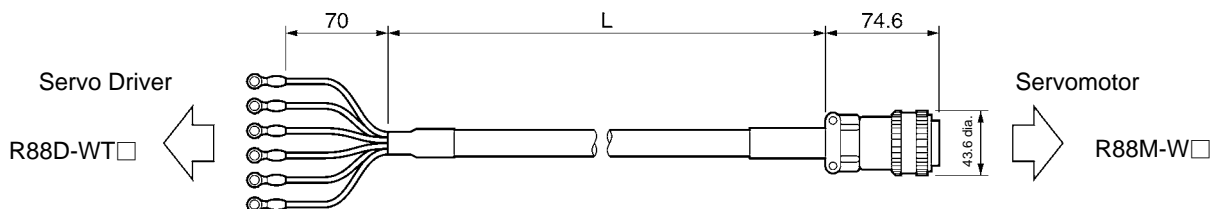

For Servomotors without Brakes

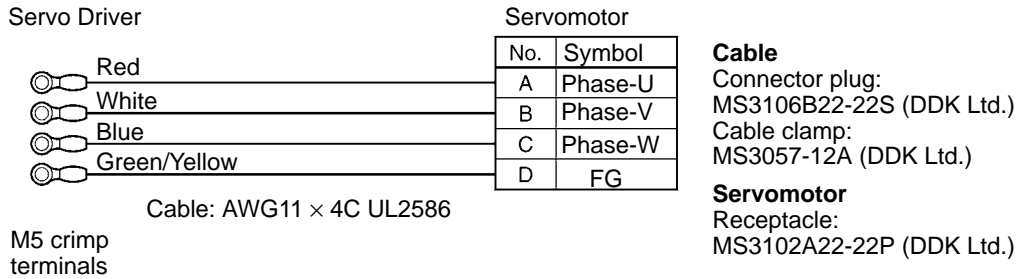

For Servomotors with Brakes

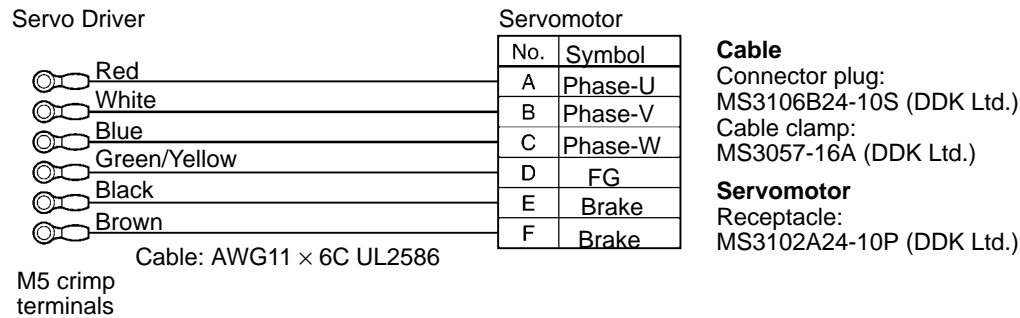

Note Connector-type terminal blocks are used for Servo Drivers of 1.5 kW or less, as shown in *Terminal Block Wiring Procedure* under 3-2-3 Terminal Block Wiring. Remove the crimp terminals from the phase-U, phase-V, and phase-W wires for these Servo Drivers. When using a 1.2-kW motor (1,000 r/min), it cannot be connected to the R88D-WT15H connector as is. Wires with ferrules must be thinned. Remove the crimp terminals from the phase-U, phase-V, and phase-W wires on the Servo Driver side and thin the conductor to approximately half.

2-6-3 Peripheral Cables and Connector Specifications

■ **Analog Monitor Cable (R88A-CMW001S)**

This is cable for connecting to the Servo Driver's Analog Monitor Connector (CN5). It is required for connecting analog monitor outputs to external devices such as measuring instruments.

● **Cable Models**

Model	Length (L)	Weight
R88A-CMW001S	1 m	Approx. 0.1 kg

● **Connection Configuration and External Dimensions**

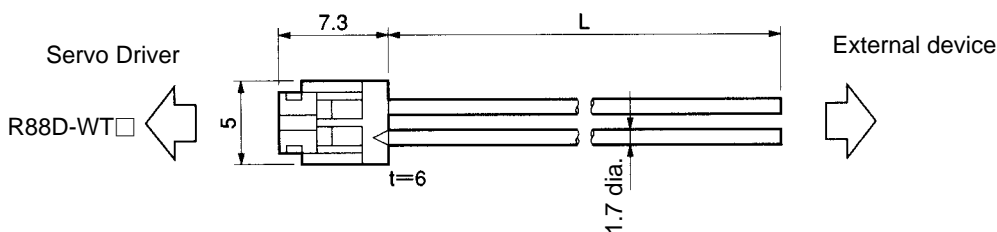

• Wiring

Servo Driver

Symbol	No.	
NM	1	Red
AM	2	White
GND	3	Black
GND	4	Black

Cable: AWG24 × 4C UL1007

Connector socket:
DF11-4DS-2C (Hirose Electric)

Connector contacts:
DF11-2428SCF (Hirose Electric)

■ Computer Monitor Cables (R88A-CCW002□P)

Computer Monitor Cable and computer monitoring software (run on Windows95) for OMNUC W-series Servo Drivers are required in order to use a personal computer for monitoring and setting parameters for a Servo Driver. There are two kinds of cable, one for DOS/V computers, and the other for NEC PC98 notebook computers (but not for PC98 desktop computers).

• Cable Models

For DOS/V Computers

Model	Length (L)	Outer diameter of sheath	Weight
R88A-CCW002P2	2 m	6 dia.	Approx. 0.1 kg

For NEC PC98 Notebook Computers

Model	Length (L)	Outer diameter of sheath	Weight
R88A-CCW002P3	2 m	6 dia.	Approx. 0.1 kg

• Connection Configuration and External Dimensions

For DOS/V Computers

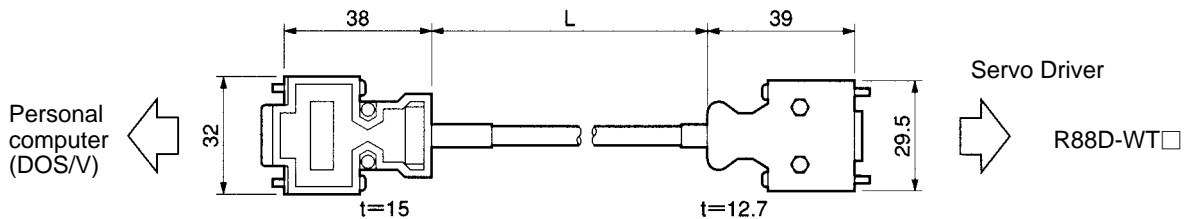

For NEC PC98 Notebook Computers

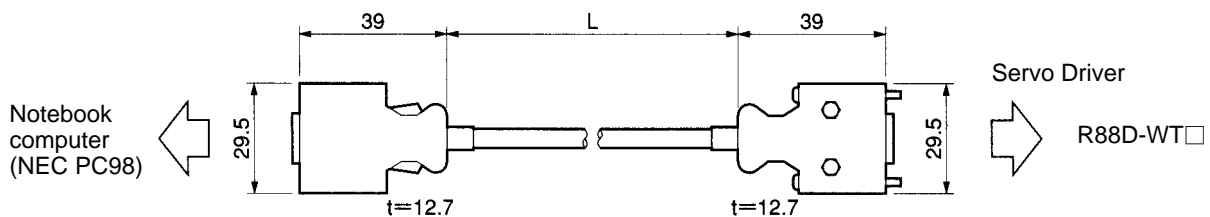

• Wiring

For DOS/V Computers

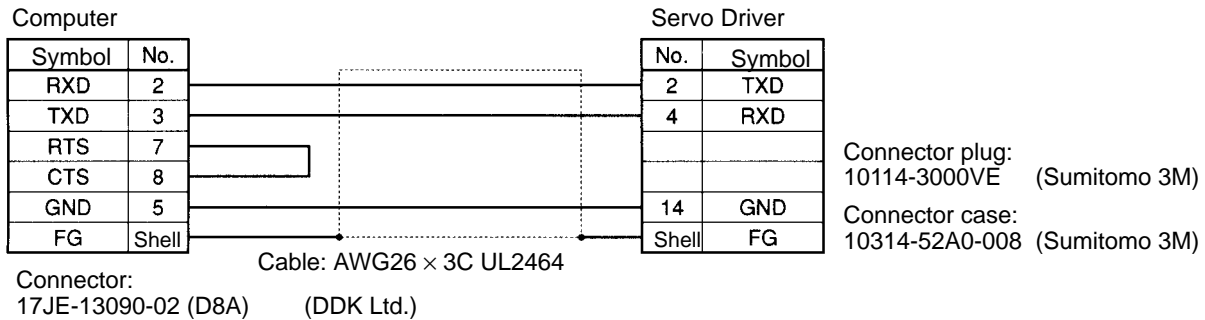

For NEC PC98 Notebook Computers

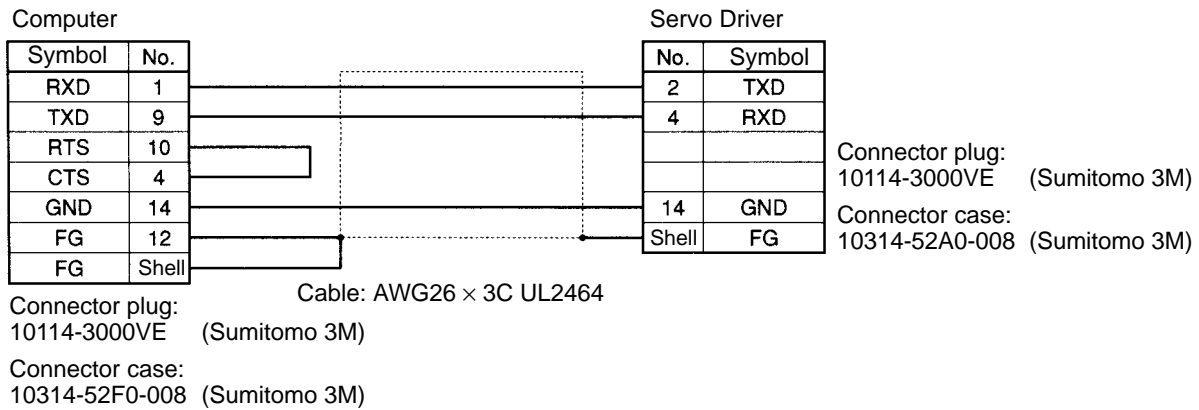

■ Control I/O Connector (R88A-CNU11C)

This is the connector for connecting to the Servo Driver's Control I/O Connector (CN1). This connector is used when the cable is prepared by the user.

• External Dimensions

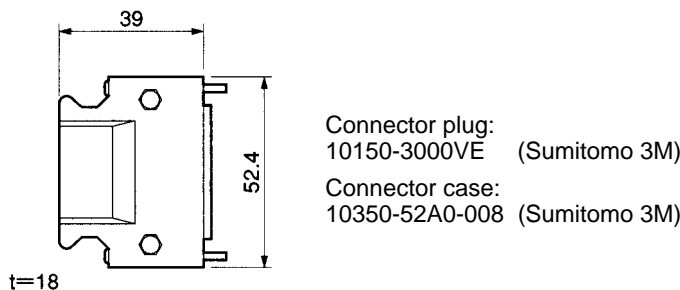

■ Encoder Connectors (R88A-CNW0□R)

These are the connectors for the encoder cable. These connectors are used when the cable is prepared by the user. They are solder-type connectors. Use the following cable.

- Wire size: AWG16 max.
- Stripped outer diameter: 2.1 mm max.
- Outer diameter of sheath: 6.7 ± 0.5 mm

• **External Dimensions**

R88A-CNW01R (For Driver's CN2 Connector)

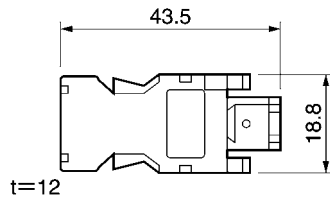

Connector Plug Model Number
55100-0670 (Molex)

R88A-CNW02R (For Motor Connector)

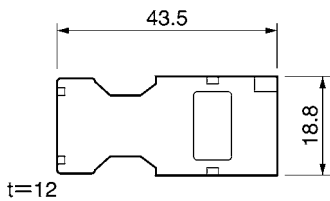

Connector Plug Model Number
54280-0609 (Molex)

2-7 Servo Relay Units and Cable Specifications

This section provides the specifications for the Servo Relay Units and cables used for connecting to OMRON Position Control Units. Select the models that match the Position Control Unit being used. For details, refer to 3-2-1 *Connecting Cable*.

All dimensions are in millimeters unless otherwise specified.

2-7-1 Servo Relay Units

■ XW2B-20J6-1B

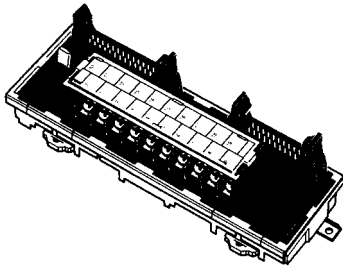

This Servo Relay Unit connects to the following OMRON Position Control Units.

- C200H-NC112
- C200HW-NC113

● External Dimensions

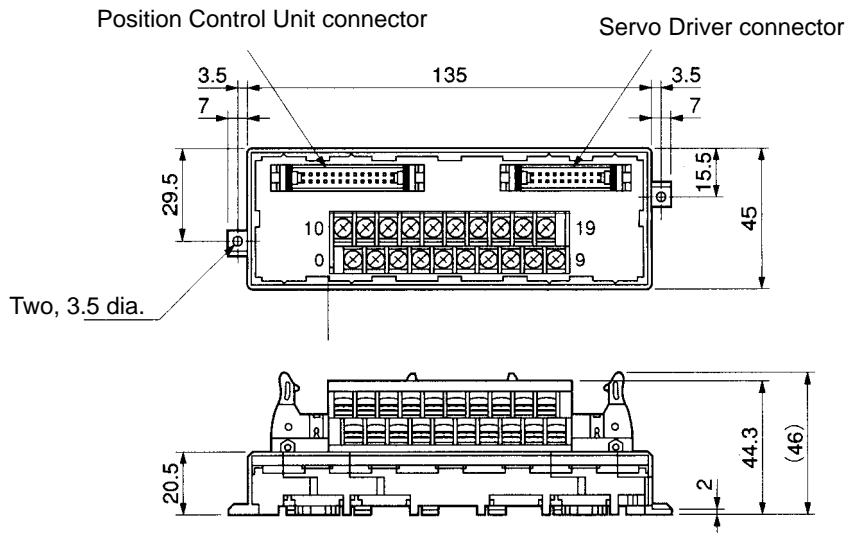

Note Terminal Block pitch: 7.62 mm

• Wiring

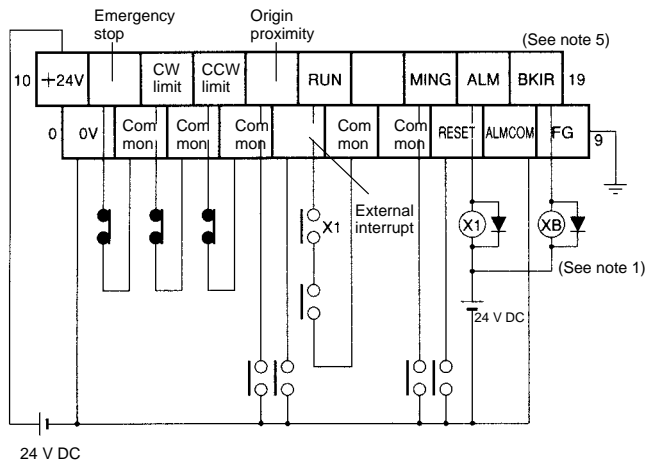

- Note**
1. The XB contact is used to turn ON/OFF the electromagnetic brake.
 2. Do not connect unused terminals.
 3. The 0 V terminal is internally connected to the common terminals.
 4. The following crimp terminal is applicable: R1.25-3 (round with open end).
 5. Allocate BKIR (Braking Lock) to CN1 pin 27.

■ XW2B-40J6-2B

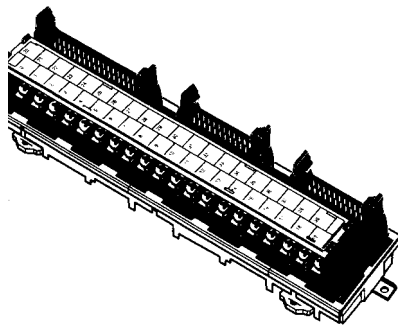

This Servo Relay Unit connects to the following OMRON Position Control Units.

- C200H-NC211
- C500-NC113/NC211
- C200HW-NC213/-NC413

• External Dimensions

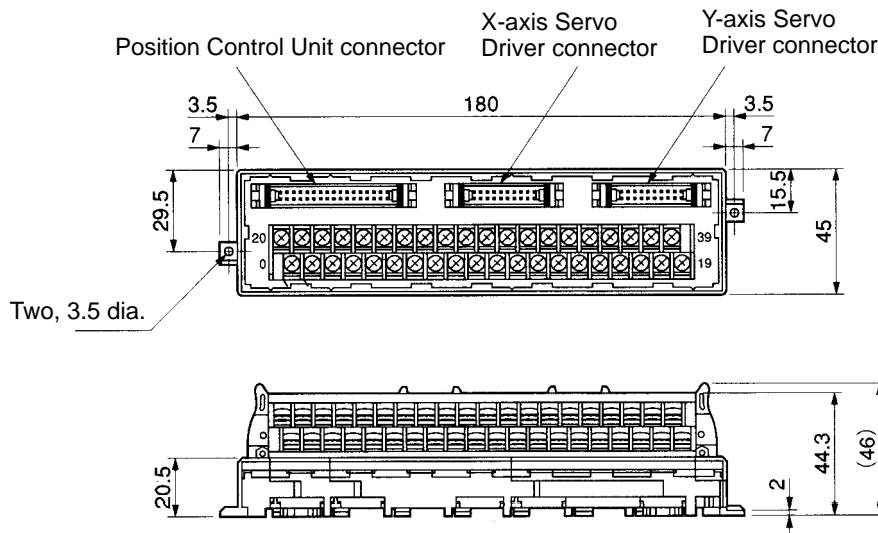

Note Terminal Block pitch: 7.62 mm

● Wiring

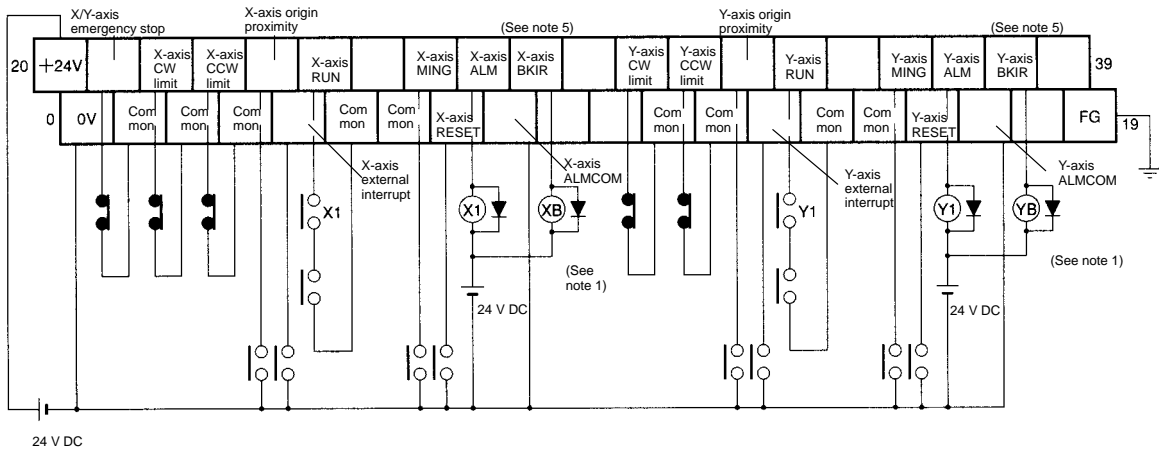

- Note 1.** The XB contact is used to turn ON/OFF the electromagnetic brake.
2. Do not connect unused terminals.
 3. The 0 V terminal is internally connected to the common terminals.
 4. The following crimp terminal is applicable: R1.25-3 (round with open end).
 5. Allocate BKIR (Braking Lock) to CN1 pin 27.

■ XW2B-20J6-3B

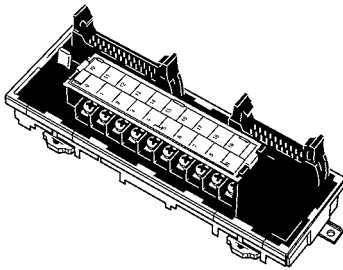

This Servo Relay Unit connects to the following OMRON Programmable Controllers.

- CQM1-CPU43-V1
- CQM1H-PLB21 (Pulse I/O Board for CQM1H-CPU51 or CQM1H-CPU61)
- CS1W-HCP22-V1

● External Dimensions

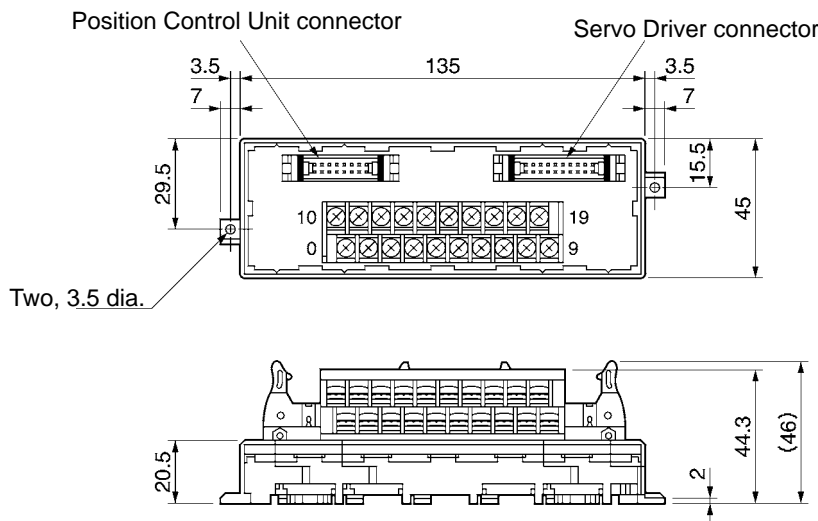

Note Terminal Block pitch: 7.62 mm

● Wiring

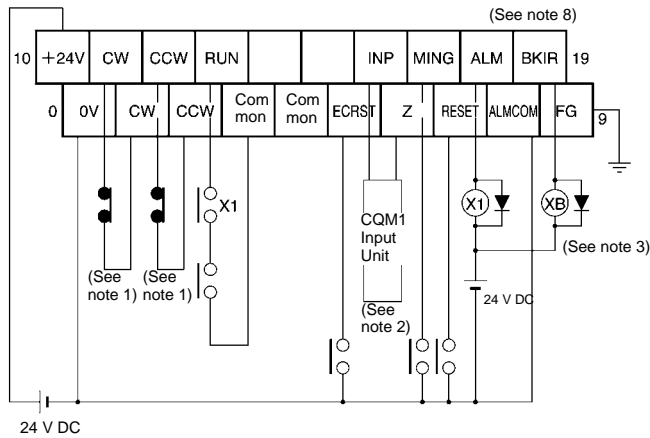

- Note**
1. If this signal is input, the output pulse from the CQM1 will be input to the high-speed counter.
 2. Input this output signal to a CQM1 Input Unit.
 3. The XB contact is used to turn ON/OFF the electromagnetic brake.
 4. The phase-Z output is an open-collector output.
 5. Do not connect unused terminals.
 6. The 0 V terminal is internally connected to the common terminals.
 7. The following crimp terminal is applicable: Radius of 1.25 to 3 (round with open end).
 8. Allocate BKIR (Braking Lock) to CN1 pin 27.

2-7-2 Cable for Servo Relay Units

■ Servo Driver Cable (XW2Z-□J-B4)

● Cable Models

Model	Length (L)	Outer diameter of sheath	Weight
XW2Z-100J-B4	1 m	8.0 dia.	Approx. 0.1 kg
XW2Z-200J-B4	2 m		Approx. 0.2 kg

● Connection Configuration and External Dimensions

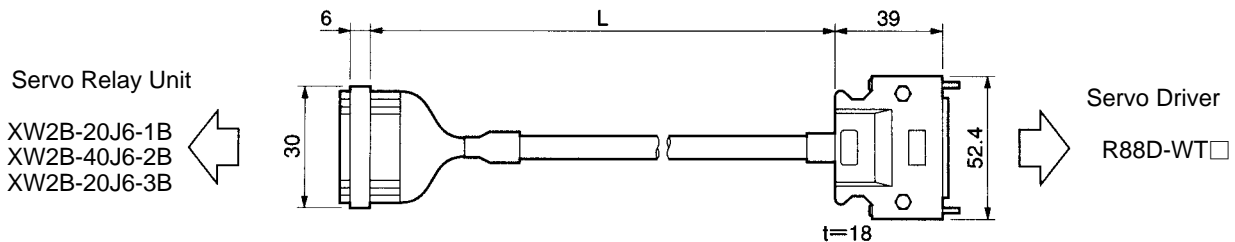

● Wiring

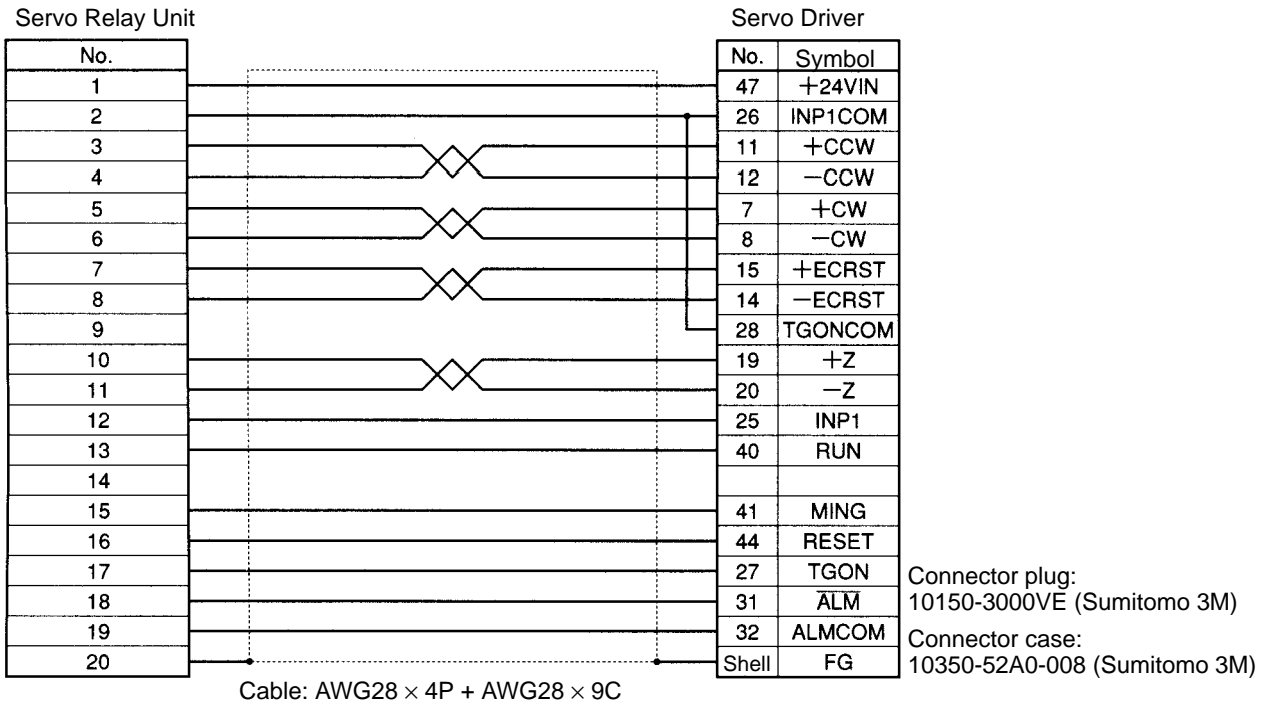

■ Position Control Unit Cable (XW2Z-□J-A2)

This is the cable for connecting between a C200H-NC211, C500-NC113, or C500-NC211 Position Control Unit and an XW2B-40J6-2B Servo Relay Unit.

● Cable Models

Model	Length (L)	Outer diameter of sheath	Weight
XW2Z-050J-A2	50 cm	10.0 dia.	Approx. 0.1 kg
XW2Z-100J-A2	1 m		Approx. 0.2 kg

● Connection Configuration and External Dimensions

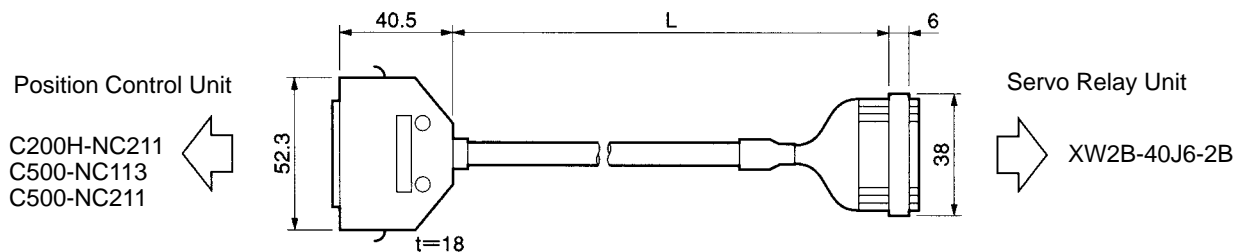

● Wiring

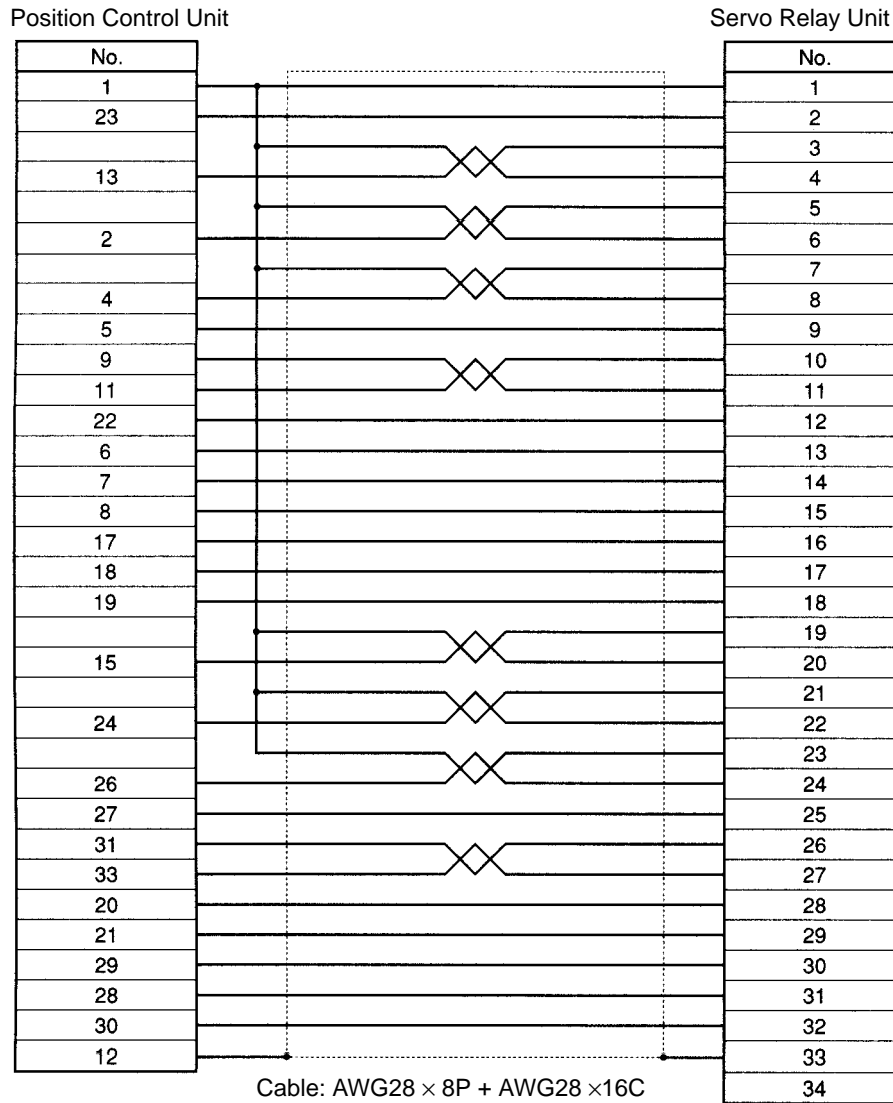

■ Position Control Unit Cable (XW2Z-□J-A3)

This is the cable for connecting between a CQM1-CPU43-V1 or CQM1H-PLB21 Programmable Controller and an XW2B-20J6-3B Servo Relay Unit.

● Cable Models

Model	Length (L)	Outer diameter of sheath	Weight
XW2Z-050J-A3	50 cm	7.5 dia.	Approx. 0.1 kg
XW2Z-100J-A3	1 m		Approx. 0.1 kg

● Connection Configuration and External Dimensions

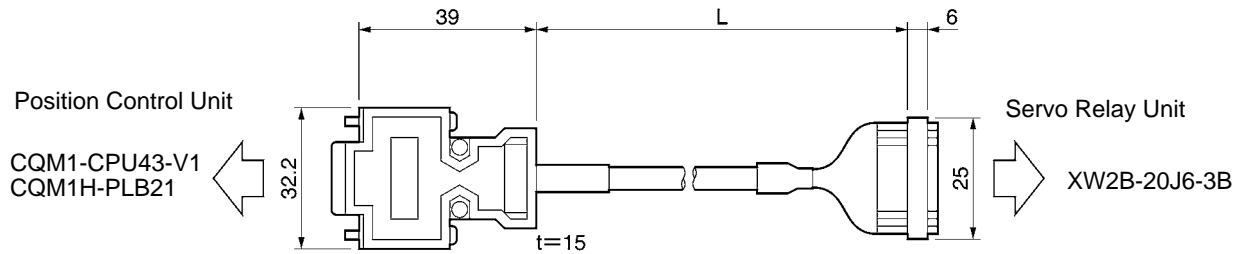

● Wiring

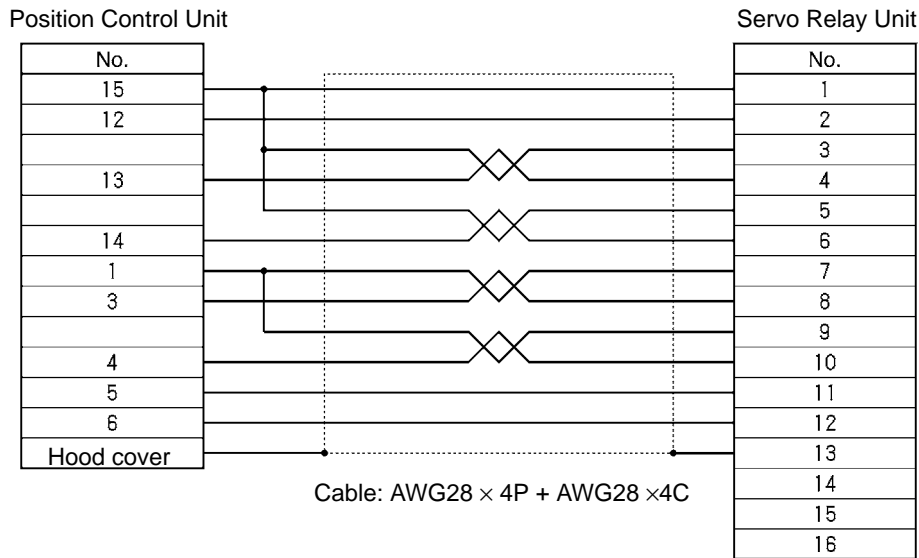

■ Position Control Unit Cable (XW2Z-□J-A6)

This is the cable for connecting between a CS1W-NC113 or C200HW-NC113 Position Control Unit and an XW2B-20J6-1B Servo Relay Unit.

● Cable Models

Model	Length (L)	Outer diameter of sheath	Weight
XW2Z-050J-A6	50 cm	8.0 dia.	Approx. 0.1 kg
XW2Z-100J-A6	1 m		Approx. 0.1 kg

● Connection Configuration and External Dimensions

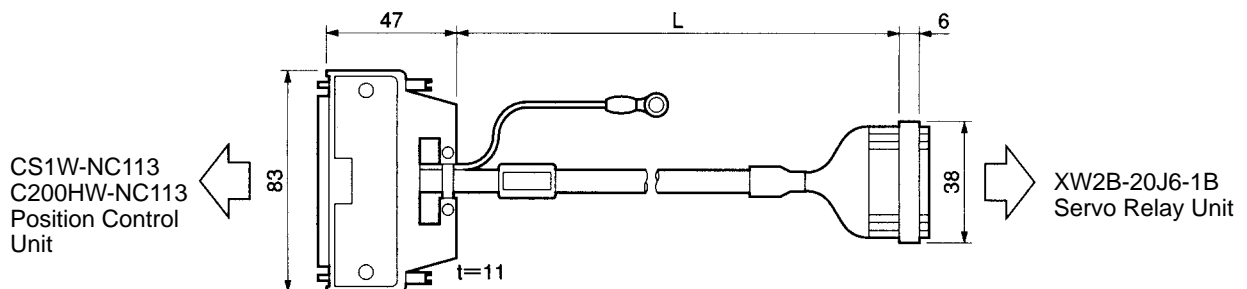

• Wiring

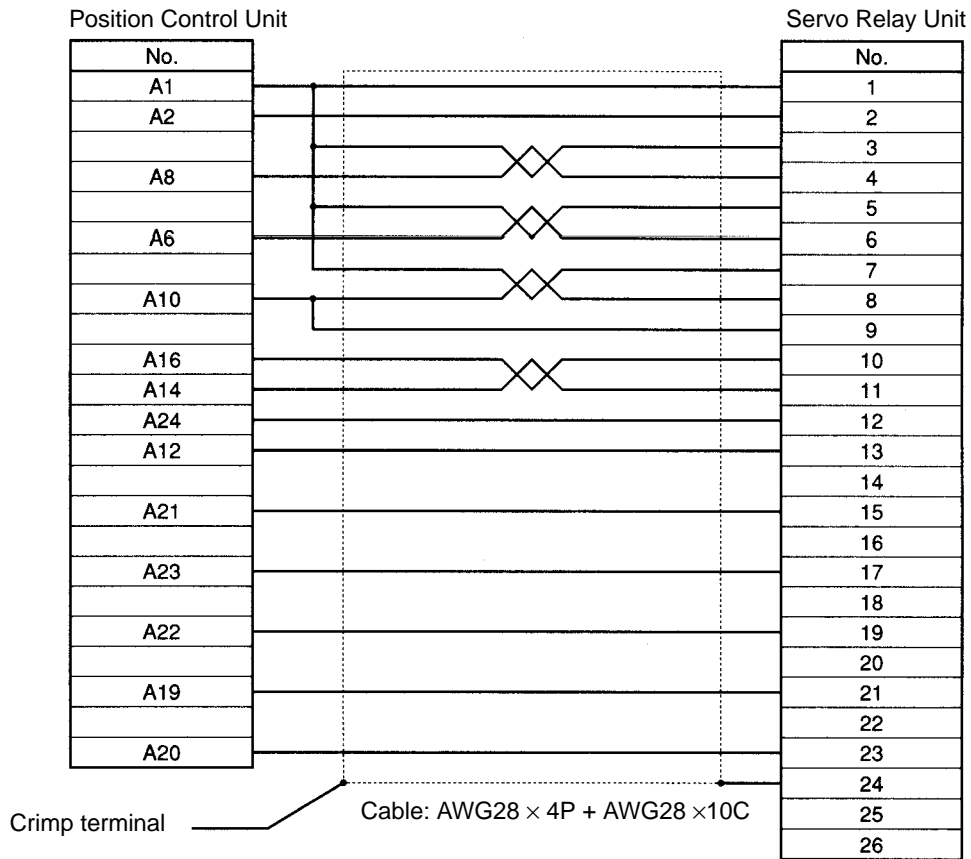

■ Position Control Unit Cable (XW2Z-□J-A7)

This is the cable for connecting between a CS1W-NC213, CS1W-NC413, C200HW-NC213 or C200HW-NC413 Position Control Unit and an XW2B-40J6-2B Servo Relay Unit.

• Cable Models

Model	Length (L)	Outer diameter of sheath	Weight
XW2Z-050J-A7	50 cm	10.0 dia.	Approx. 0.1 kg
XW2Z-100J-A7	1 m		Approx. 0.2 kg

• Connection Configuration and External Dimensions

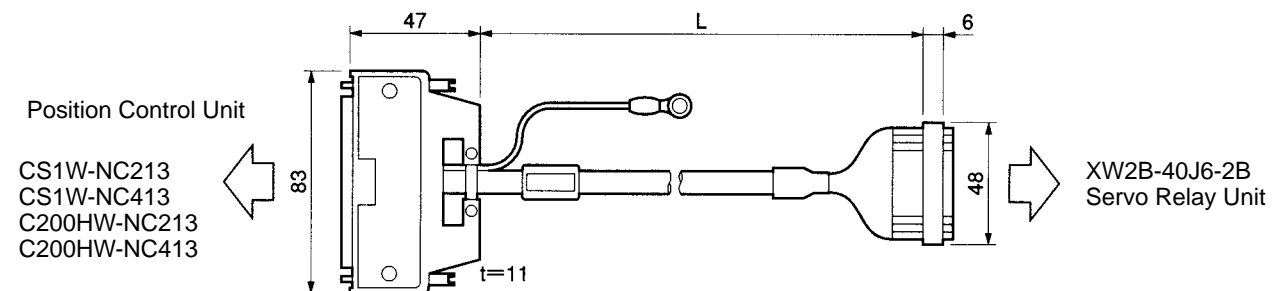

• Wiring

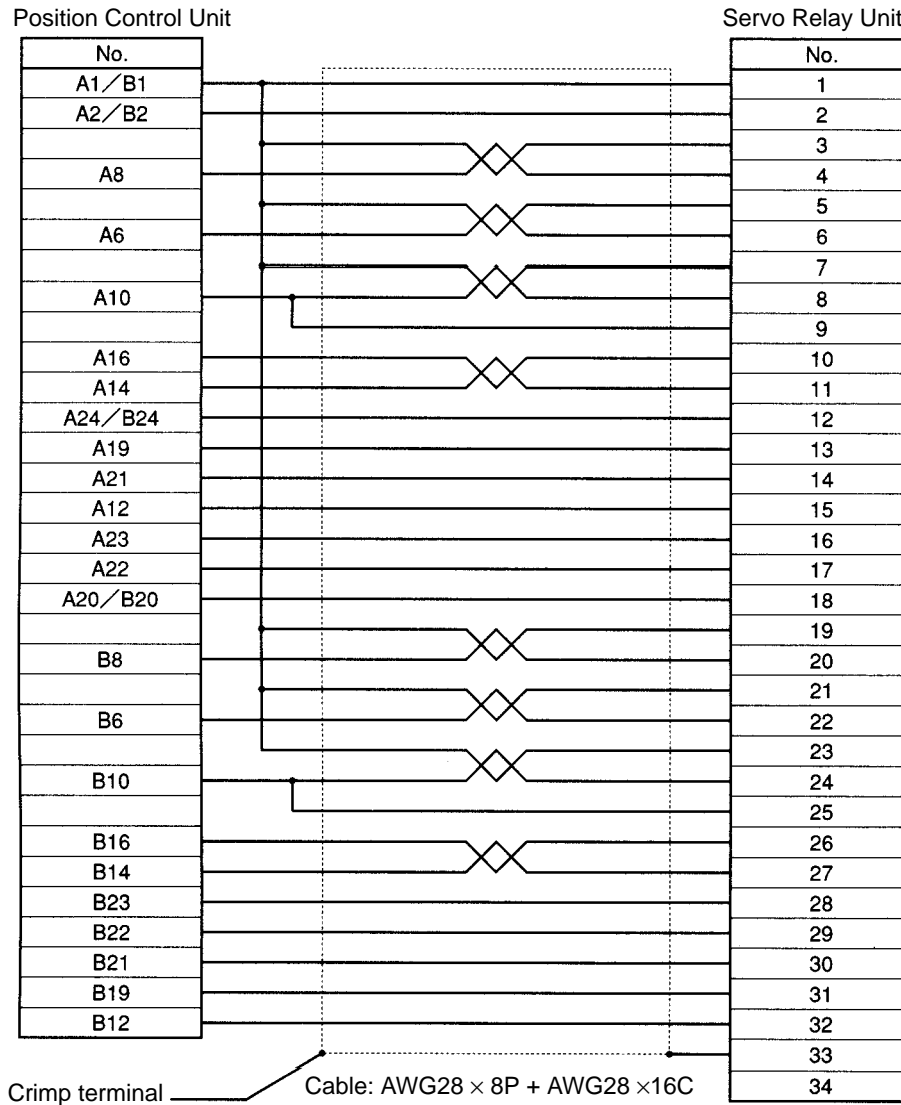

■ Position Control Unit Cable (XW2Z-□J-A10)

This is the cable for connecting between a CS1W-NC133 Position Control Unit and an XW2B-20J6-1B Servo Relay Unit.

• Cable Models

Model	Length (L)	Outer diameter of sheath	Weight
XW2Z-050J-A10	50 cm	10.0 dia.	Approx. 0.1 kg
XW2Z-100J-A10	1 m		Approx. 0.2 kg

● Connection Configuration and External Dimensions

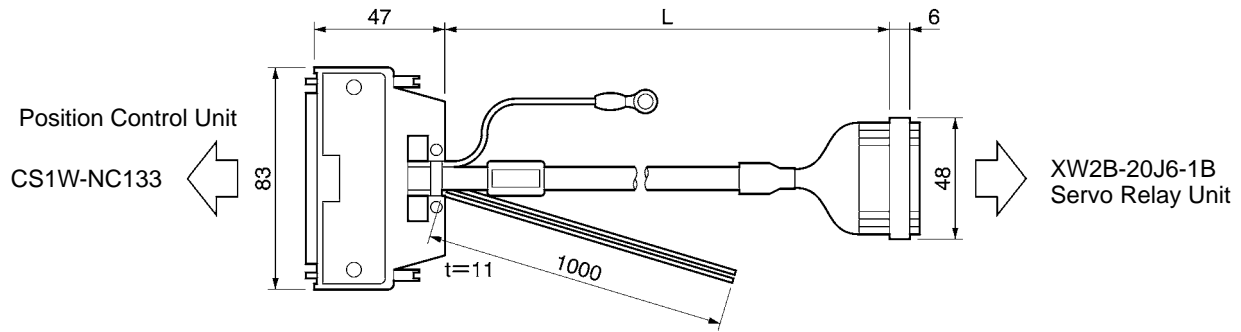

● Wiring

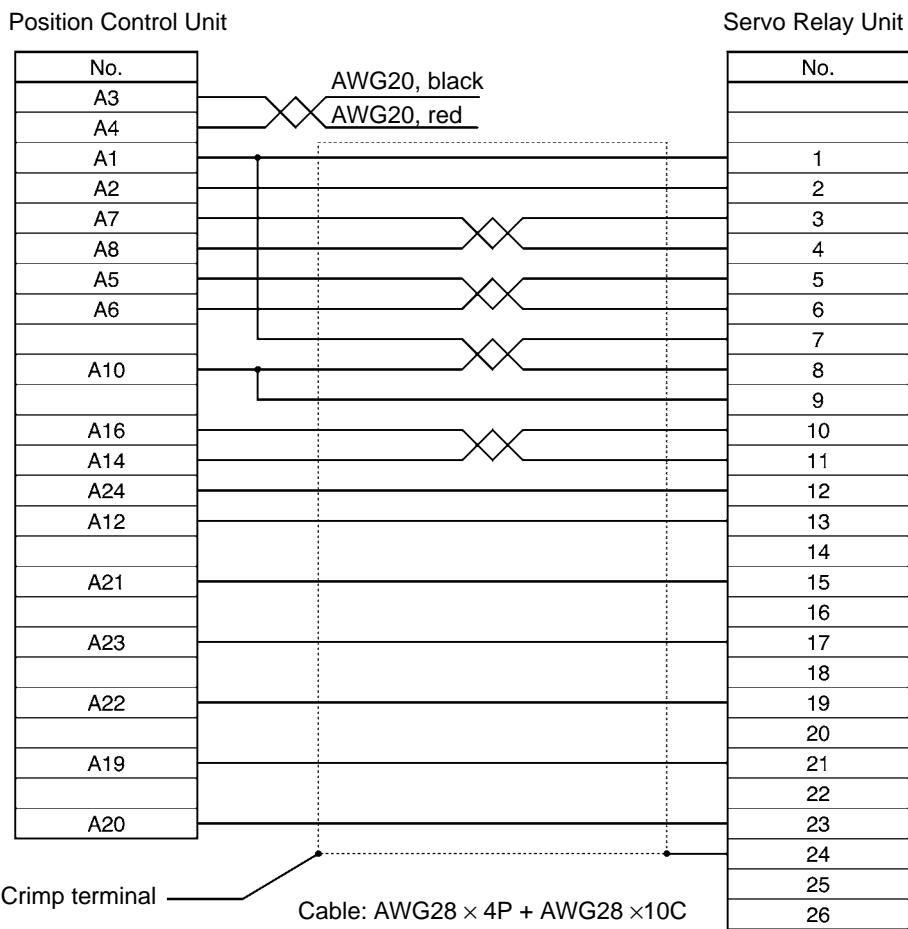

■ Position Control Unit Cable (XW2Z-□J-A11)

This is the cable for connecting between a CS1W-NC233/433 Position Control Unit and an XW2B-40J6-2B Servo Relay Unit.

● Cable Models

Model	Length (L)	Outer diameter of sheath	Weight
XW2Z-050J-A11	50 cm	10.0 dia.	Approx. 0.1 kg
XW2Z-100J-A11	1 m		Approx. 0.2 kg

● Connection Configuration and External Dimensions

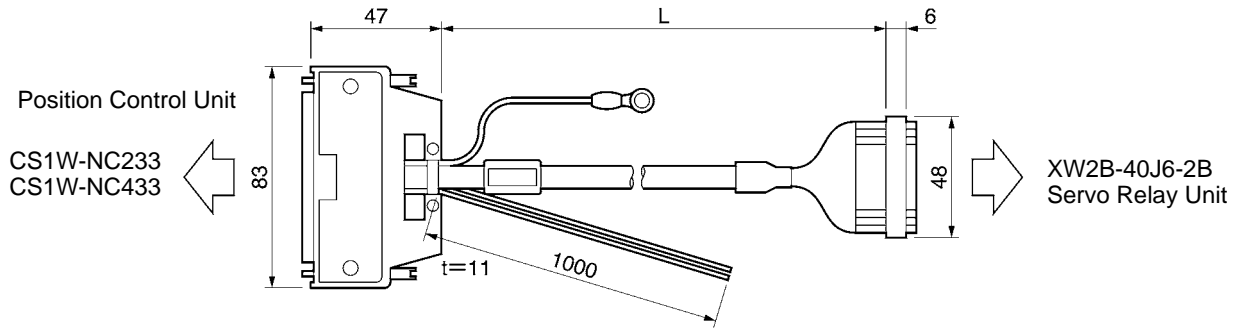

● Wiring

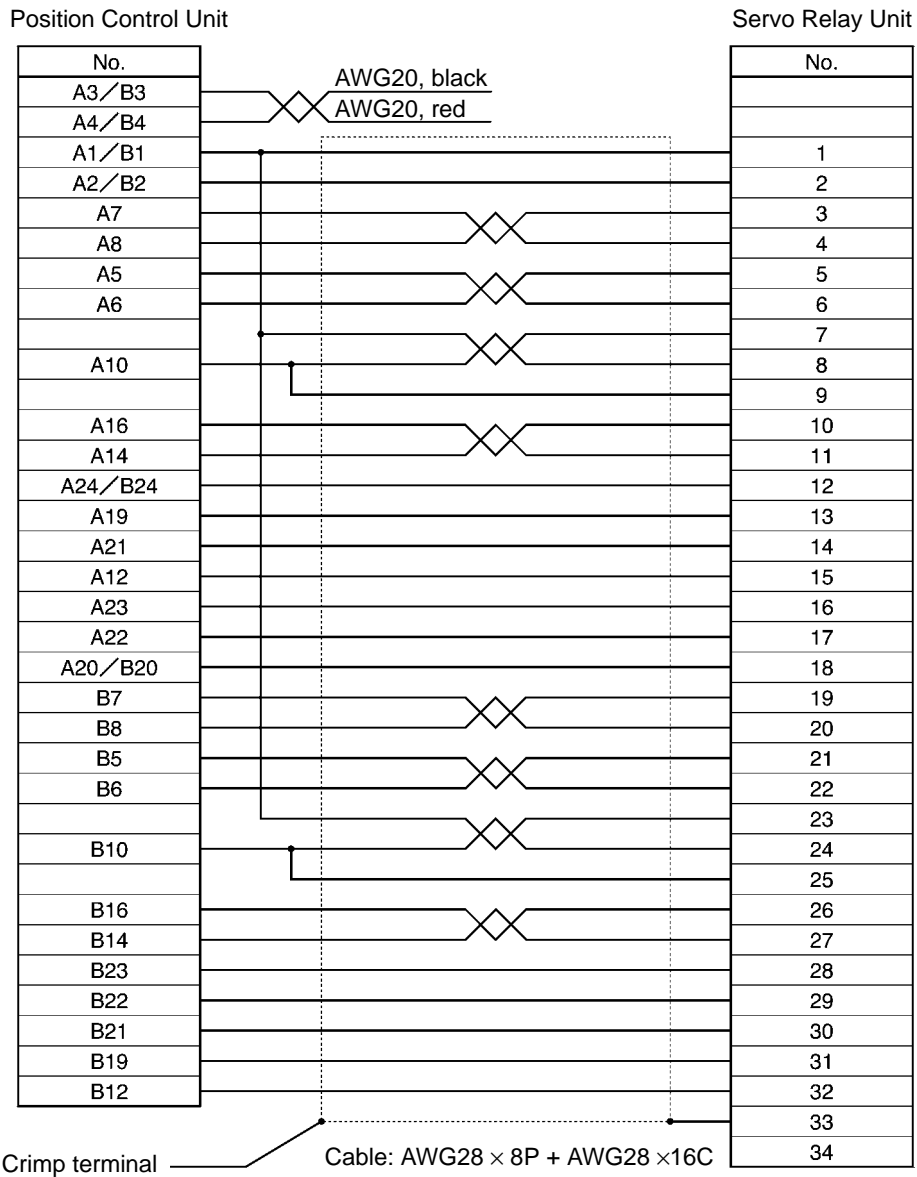

■ Position Control Unit Cable (XW2Z-□J-A14)

This is the cable for connecting between a CJ1W-NC113 Position Control Unit and an XW2B-20J6-1B Servo Relay Unit.

● Cable Models

Model	Length (L)	Outer diameter of sheath	Weight
XW2Z-050J-A14	50 cm	10.0 dia.	Approx. 0.1 kg
XW2Z-100J-A14	1 m		Approx. 0.2 kg

● Connection Configuration and External Dimensions

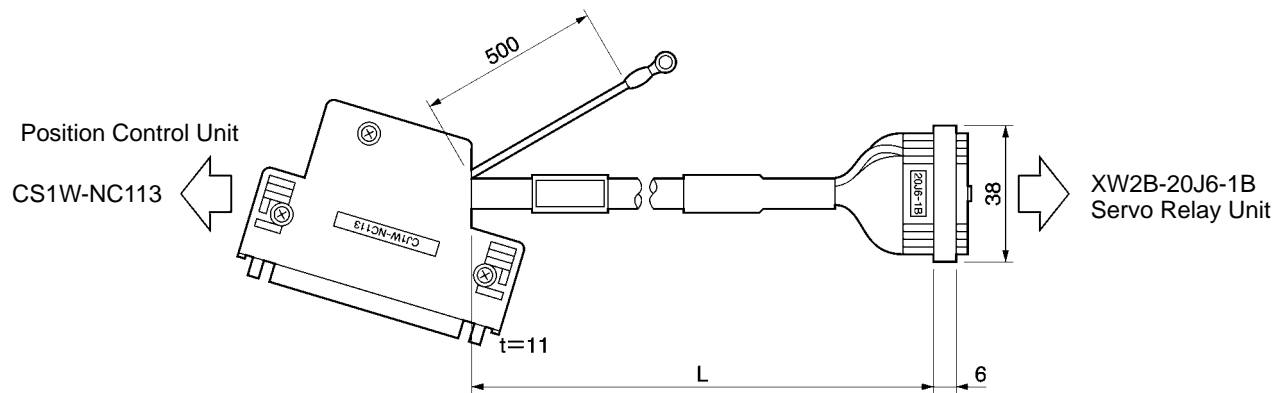

● Wiring

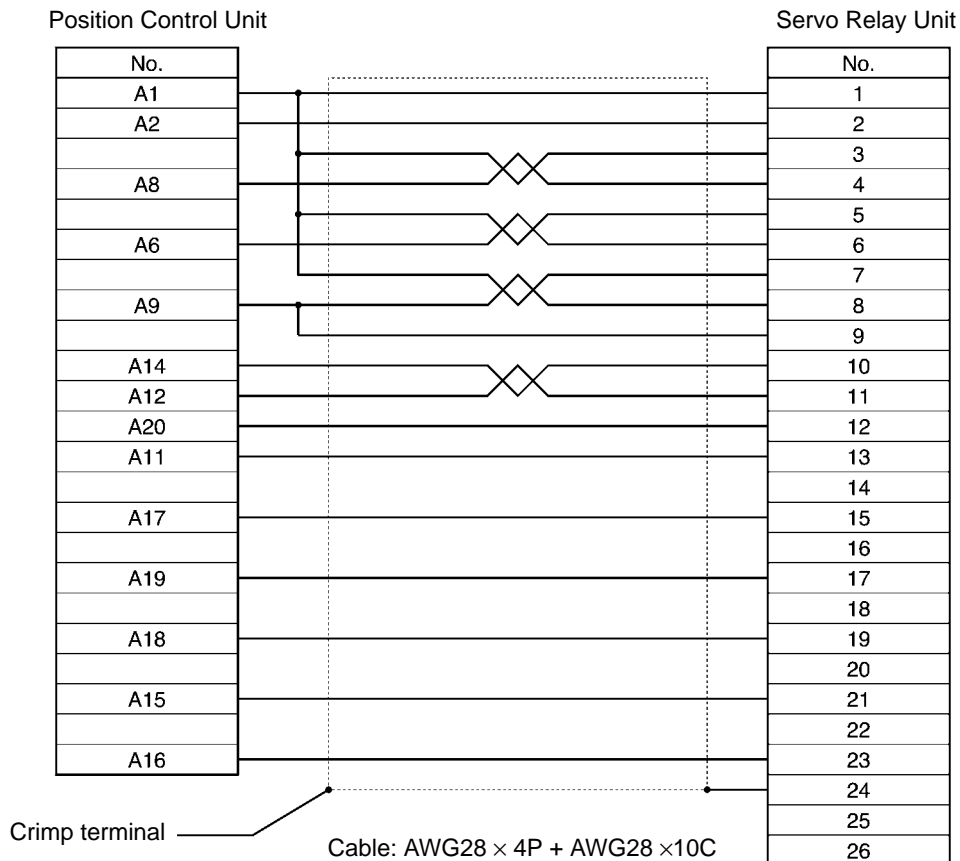

■ Position Control Unit Cable (XW2Z-□J-A15)

This is the cable for connecting between a CJ1W-NC213/NC413 Position Control Unit and an XW2B-40J6-2B Servo Relay Unit.

● Cable Models

Model	Length (L)	Outer diameter of sheath	Weight
XW2Z-050J-A15	50 cm	10.0 dia.	Approx. 0.1 kg
XW2Z-100J-A15	1 m		Approx. 0.2 kg

● Connection Configuration and External Dimensions

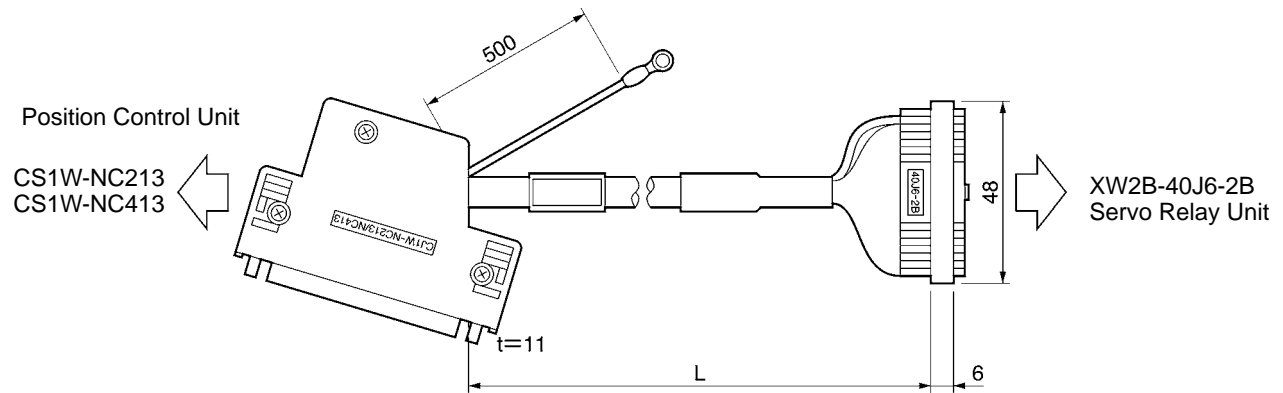

• Wiring

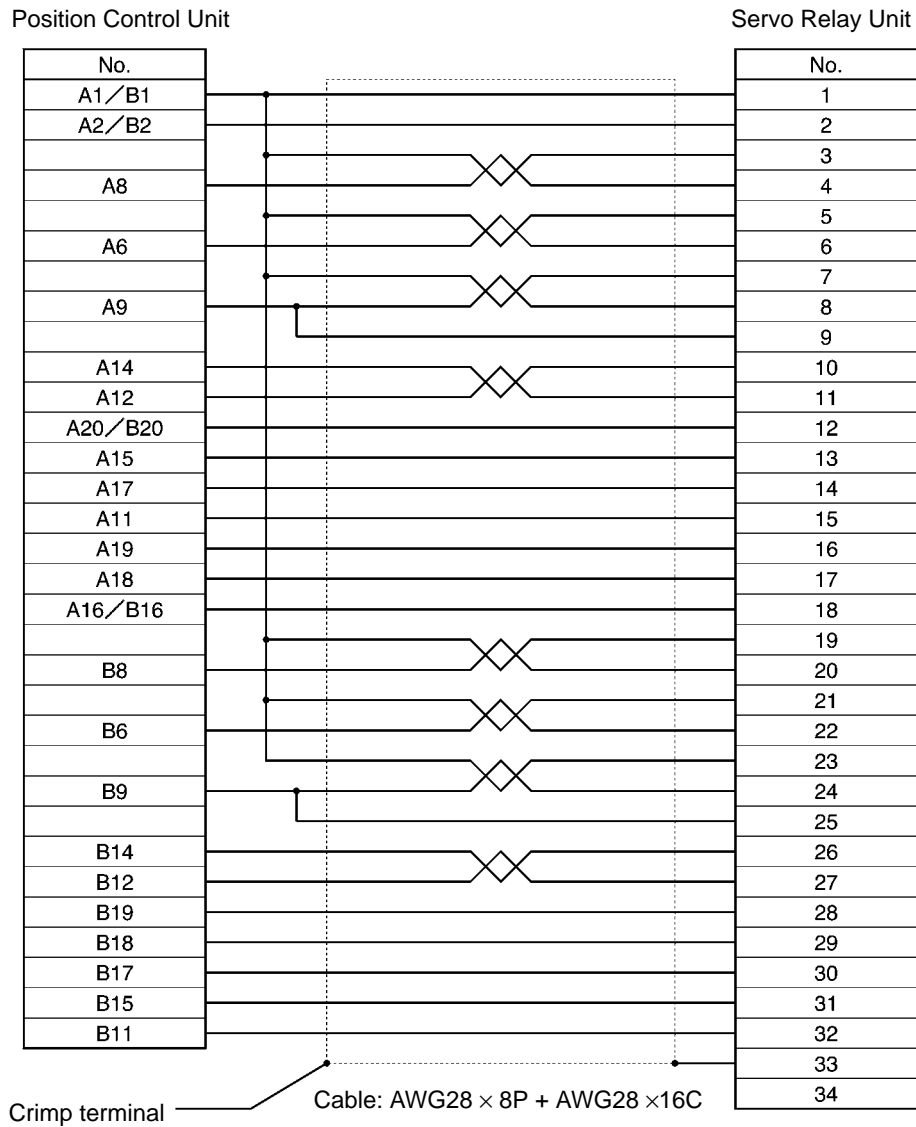

■ Position Control Unit Cable (XW2Z-□J-A18)

This is the cable for connecting between a CJ1W-NC133 Position Control Unit and an XW2B-20J6-1B Servo Relay Unit.

• Cable Models

Model	Length (L)	Outer diameter of sheath	Weight
XW2Z-050J-A18	50 cm	10.0 dia.	Approx. 0.1 kg
XW2Z-100J-A18	1 m		Approx. 0.2 kg

● Connection Configuration and External Dimensions

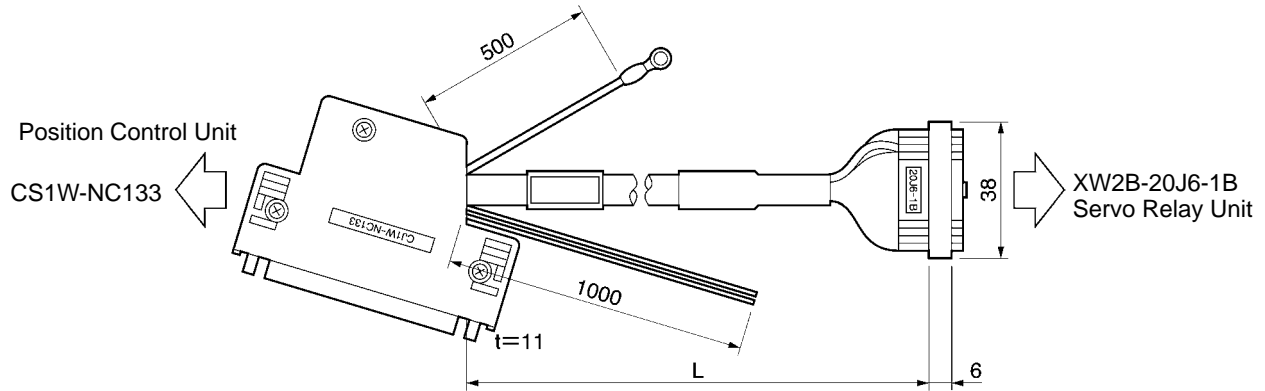

● Wiring

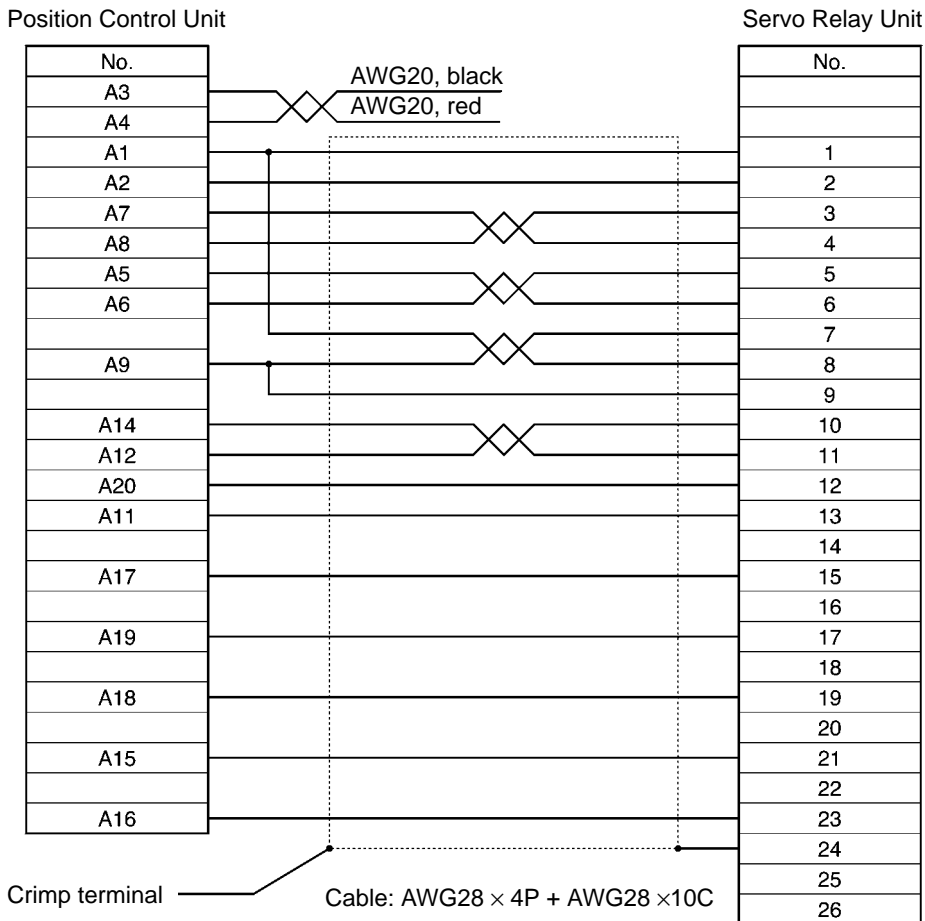

■ Position Control Unit Cable (XW2Z-□J-A19)

This is the cable for connecting between a CJ1W-NC233/NC433 Position Control Unit and an XW2B-40J6-2B Servo Relay Unit.

● Cable Models

Model	Length (L)	Outer diameter of sheath	Weight
XW2Z-050J-A19	50 cm	10.0 dia.	Approx. 0.1 kg
XW2Z-100J-A19	1 m		Approx. 0.2 kg

● Connection Configuration and External Dimensions

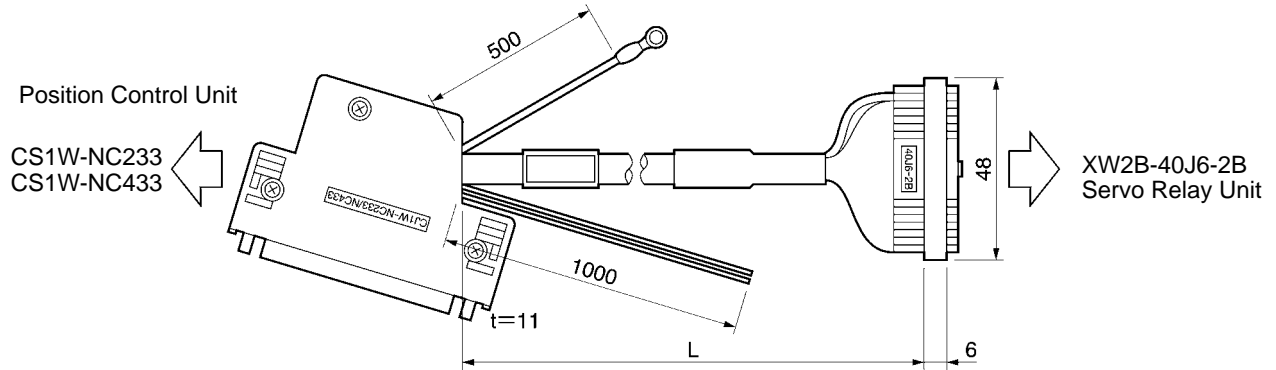

• Wiring

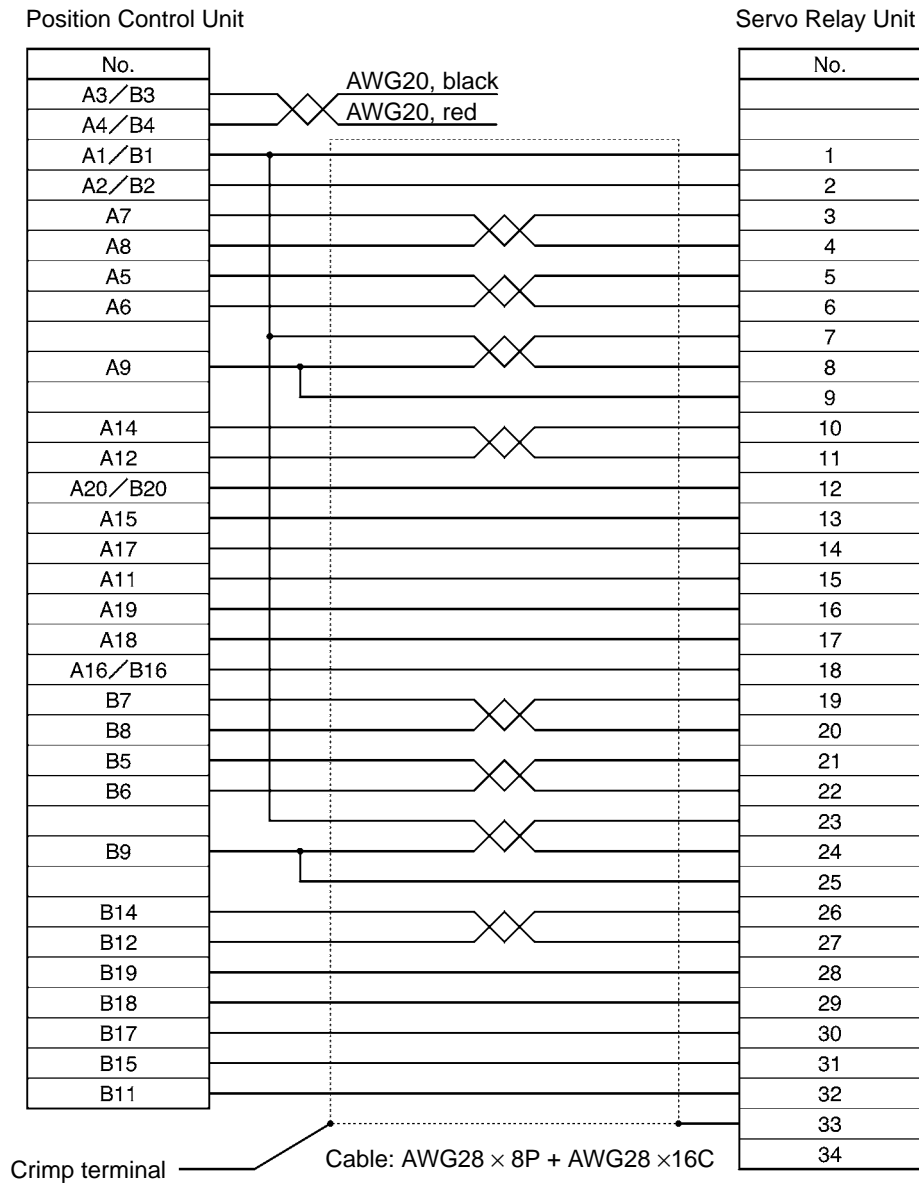

■ Position Control Unit Cable (XW2Z-□J-A22)

This is the cable for connecting between a CS1W-HCP22-V1 Position Control Unit and an XW2B-20J6-3B Servo Relay Unit.

• Cable Models

Model	Length (L)	Outer diameter of sheath	Weight
XW2Z-050J-A22	50 cm	10.0 dia.	Approx. 0.1 kg
XW2Z-100J-A22	1 m		Approx. 0.2 kg

● Connection Configuration and External Dimensions

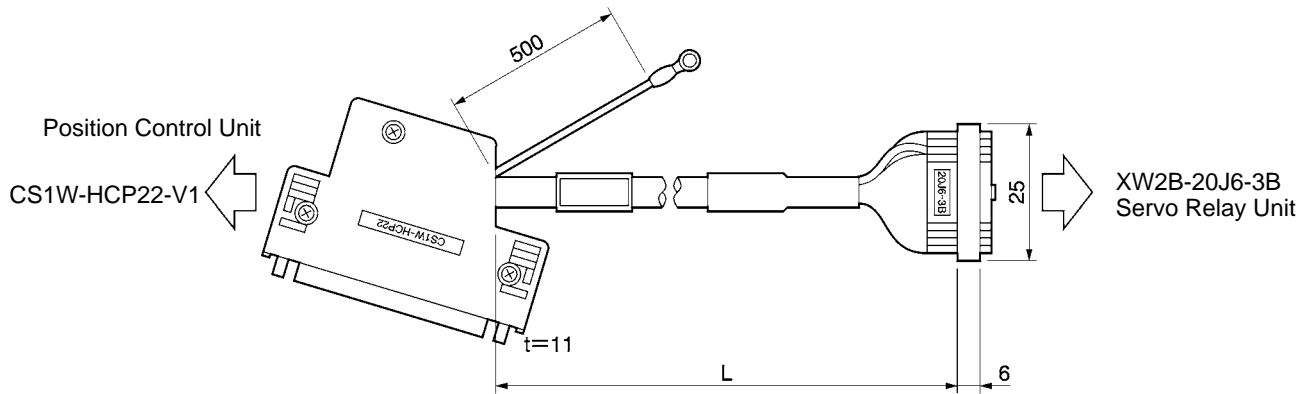

● Wiring

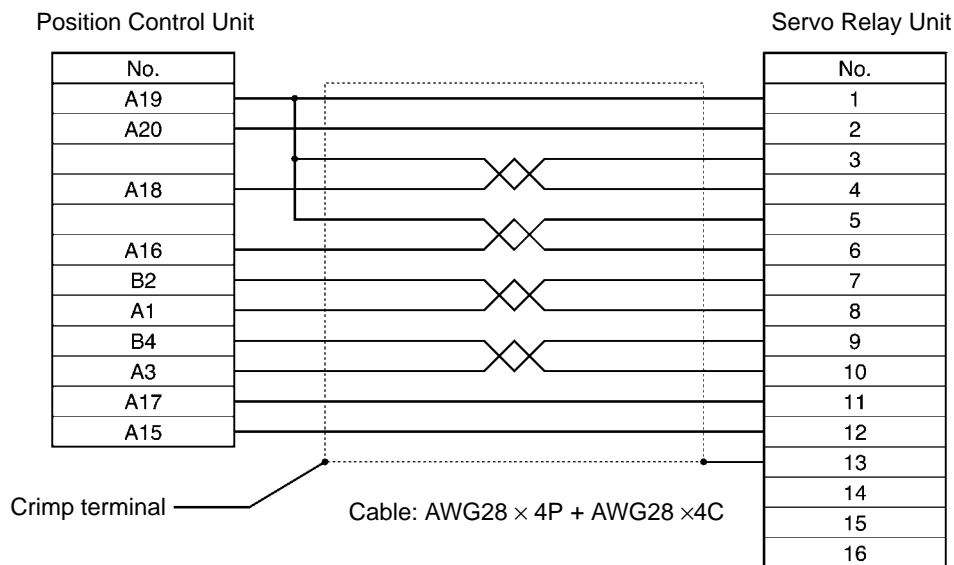

■ Position Control Unit Cable (XW2Z-□J-A23)

This is the cable for connecting between a CS1W-HCP22-V1 Position Control Unit and an XW2B-20J6-3B Servo Relay Unit.

● Cable Models

Model	Length (L)	Outer diameter of sheath	Weight
XW2Z-050J-A23	50 cm	10.0 dia.	Approx. 0.1 kg
XW2Z-100J-A23	1 m		Approx. 0.2 kg

● Connection Configuration and External Dimensions

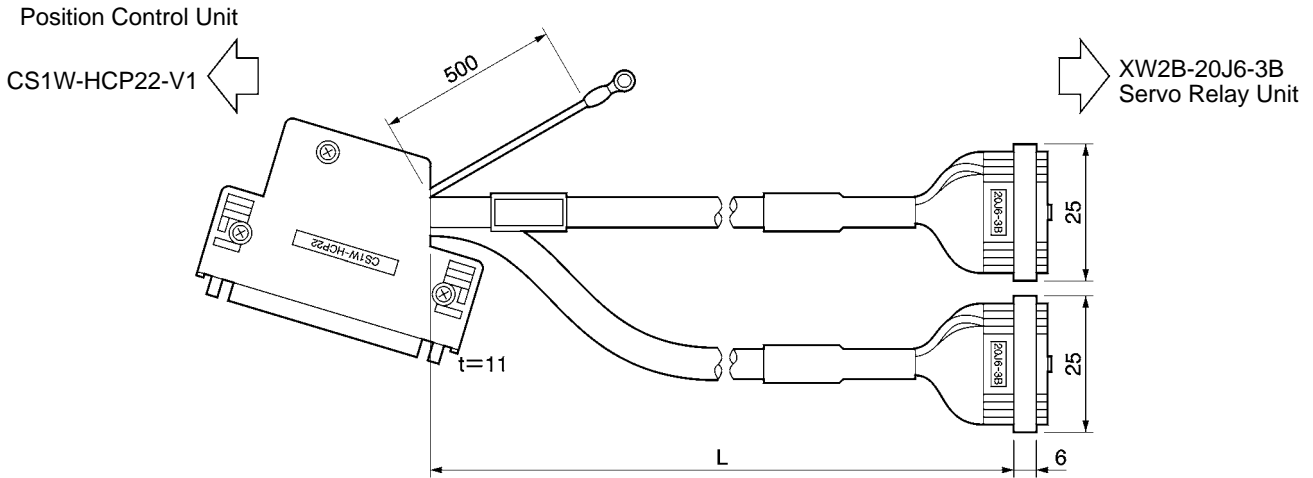

● Wiring

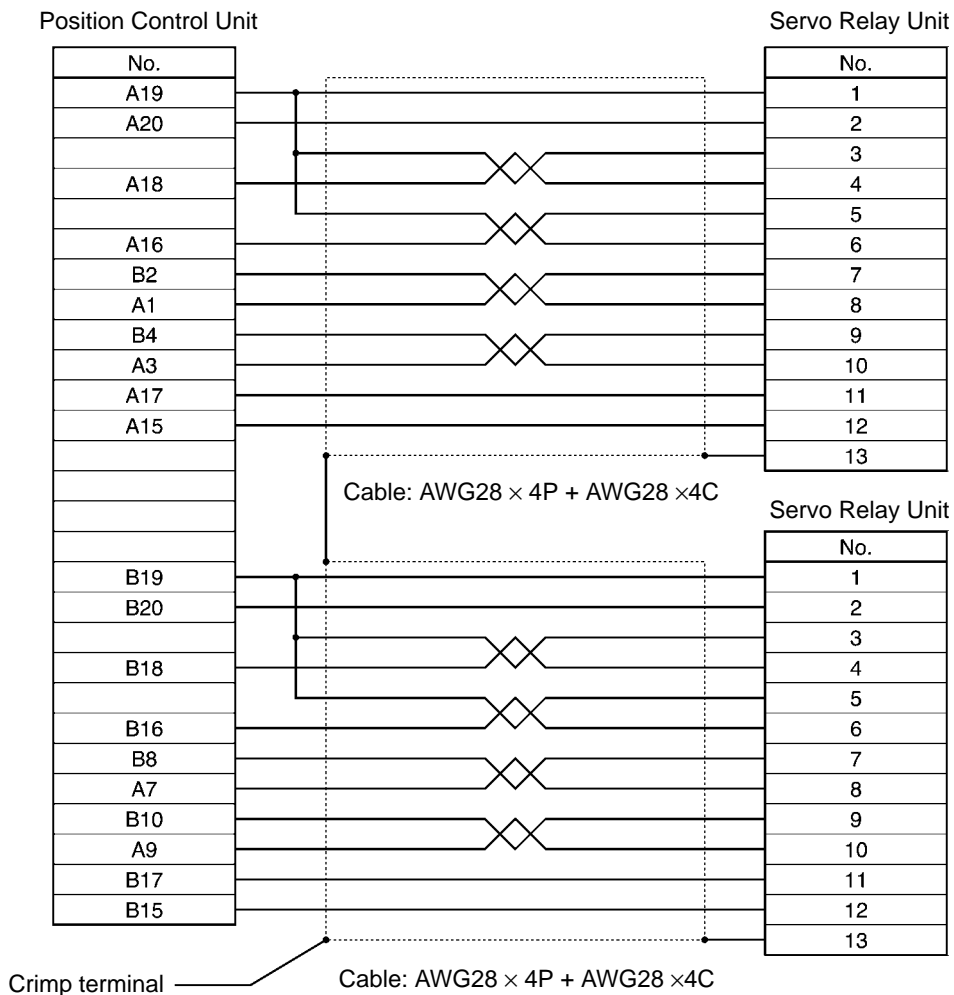

■ Position Control Unit Cable (XW2Z-□J-A24)

This is the cable for connecting between a 3F88M-DRT141 DeviceNet Single-axis Positioner and an XW2B-20J6-1B Servo Relay Unit.

● Cable Models

Model	Length (L)	Outer diameter of sheath	Weight
XW2Z-050J-A24	50 cm	10.0 dia.	Approx. 0.1 kg
XW2Z-100J-A24	1 m		Approx. 0.2 kg

● Connection Configuration and External Dimensions

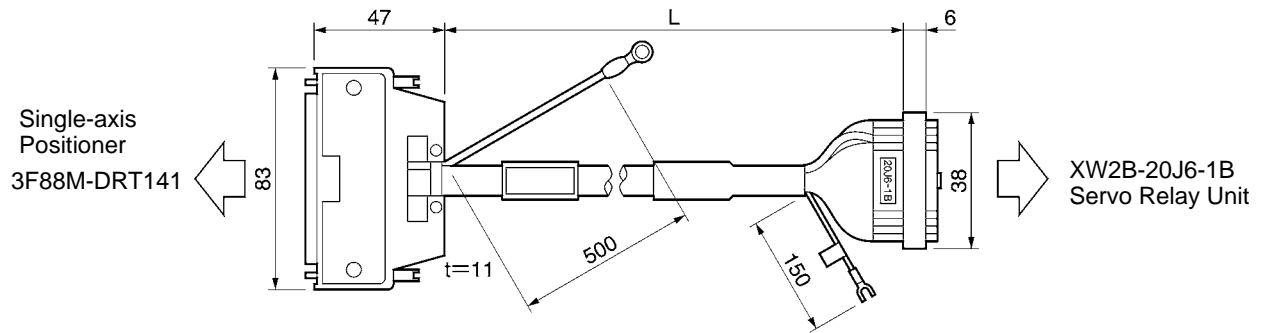

• Wiring

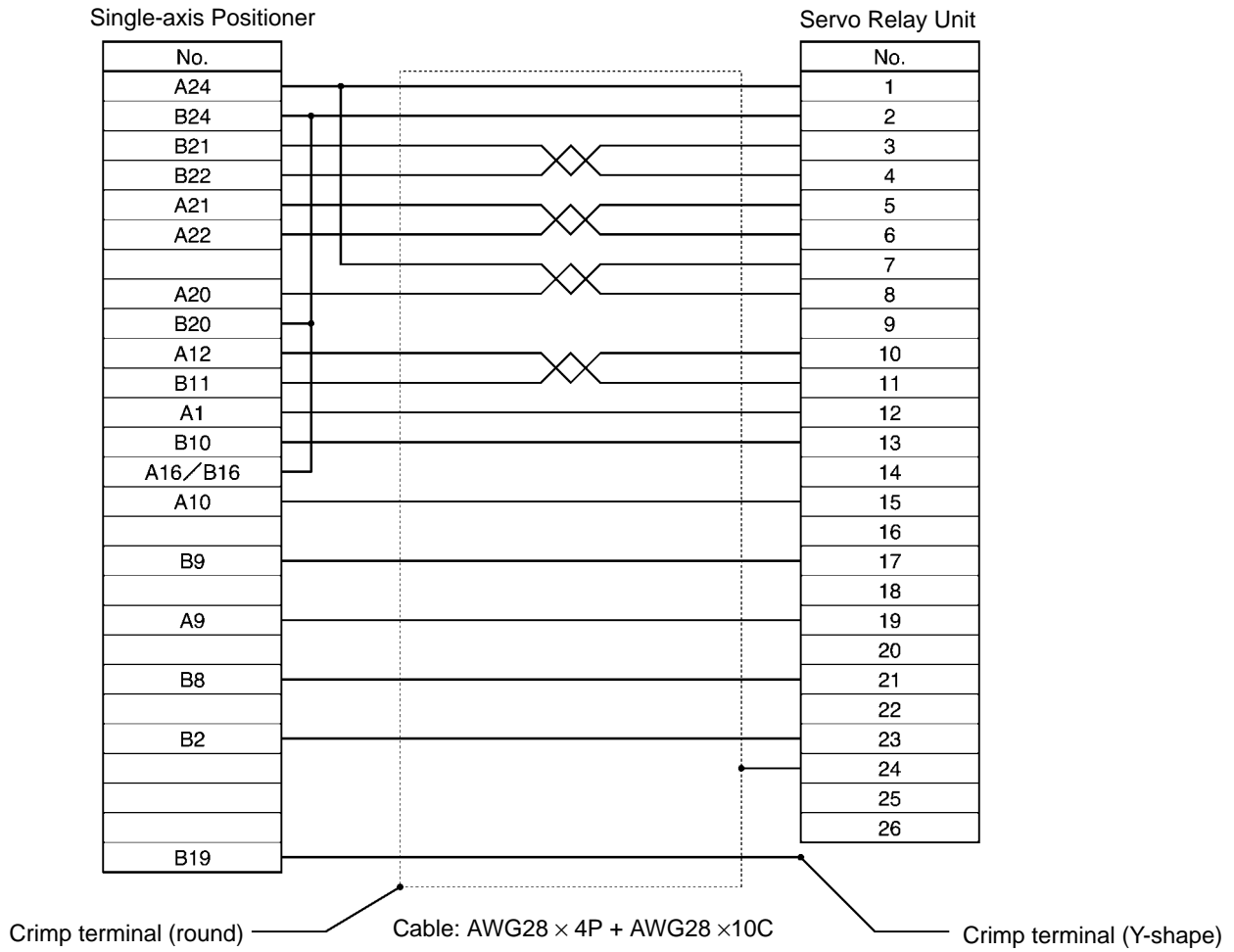

2-8 Parameter Unit and Cable Specifications

All dimensions are in millimeters unless otherwise specified.

2-8-1 Parameter Unit

■ R88A-PR02W Hand-held Parameter Unit

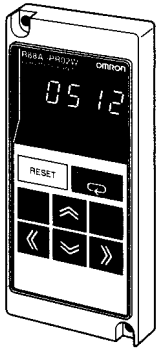

Parameter Units are required for operation and monitoring the Servo Driver at a remote location or with a control panel.

Note A 1-meter cable is provided with the Parameter Unit. If this is not long enough to connect between the Parameter Unit and the Servo Driver, then use the R88A-CCW002C Parameter Unit Cable (2 meters, purchased separately).

■ General Specifications

Item	Standards
Operating ambient temperature	0 to 55°C
Storage ambient temperature	-10 to 75°C
Operating ambient humidity	35% to 85% (with no condensation)
Storage ambient humidity	35% to 85% (with no condensation)
Storage and operating atmosphere	No corrosive gasses.
Vibration resistance	4.9 m/s ² max.
Impact resistance	Acceleration 19.6 m/s ² max.

■ Performance Specifications

Model		Standards	
Type		Hand-held	
Accessory cable		1 m	
Connectors		7910-7500SC (10 pins)	
Display		7-segment LED	
External dimensions		63 × 135 × 18.5 mm (W × H × D)	
Weight		Approx. 0.2 kg (including 1-m cable that is provided)	
Communications specifications	Standard	RS-232C	
	Communications method	Asynchronous (ASYNC)	
	Baud rate	2,400 bps	
	Start bits	1 bit	
	Data	8 bits	
	Parity	None	
	Stop bits	1 bit	
Errors detected by Parameter Unit	Display	CPF00	Cannot transmit even after 5 seconds have elapsed since power supply was turned on.
		CPF01	A BCC error or faulty reception data has occurred for five consecutive times, or a time overrun (1 s) has occurred for three consecutive times.

2-8-2 Parameter Unit Cable (R88A-CCW002C)

If the 1-meter cable provided with the Parameter Unit is not long enough, then replace it with R88A-CCW002C Parameter Unit Cable (2 meters).

Note If this cable is connected to an OMNUC U-series Hand-held Parameter Unit (R88A-PR02U), the Parameter Unit can be used as an OMNUC W-series Parameter Unit. (Operation is the same as for the R88A-PR02W.)

● Cable Models

Model	Length (L)	Outer diameter of sheath	Weight
R88A-CCW002C	2 m	6 dia.	Approx. 0.2 kg

● Connection Configuration and External Dimensions

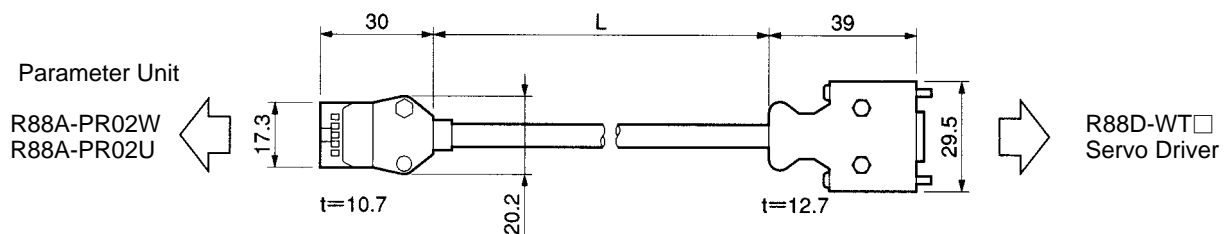

• Wiring

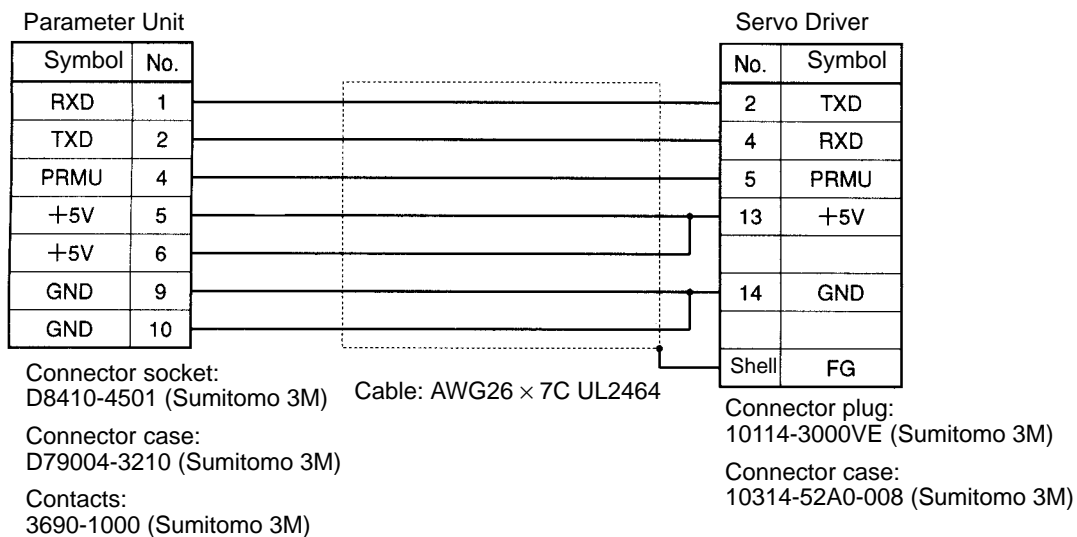

2-9 External Regeneration Resistors/Resistance Units

If the Servomotor's regenerative energy is excessive, connect an External Regeneration Resistor or an External Regeneration Resistance Unit.

- R88A-RR22047S External Regeneration Resistor
R88A-RR88006 External Regeneration Resistance Unit

■ Specifications

Model	Resistance	Nominal capacity	Regeneration absorption for 120°C temperature rise	Heat radiation condition	Thermal switch output specifications
R88A-RR22047S	47 Ω ± 5%	220 W	70 W	t1.0 × □350 (SPCC)	Operating temperature: 170°C±3%, NC contact, Rated output: 3 A
R88A-RR88006	6.25 Ω ± 10%	880 W	180 W	—	—

■ External Dimensions

All dimensions are in millimeters.

- R88A-RR22047S External Regeneration Resistor

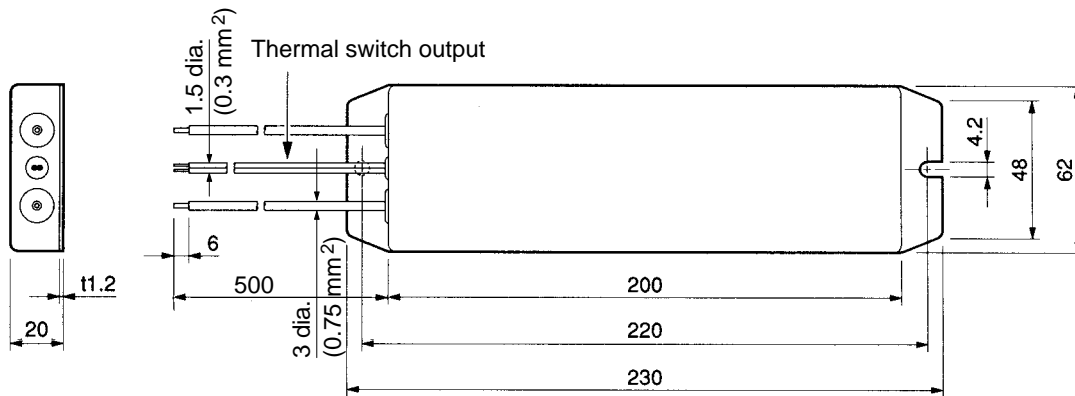

• R88A-RR88006 External Regeneration Resistance Unit

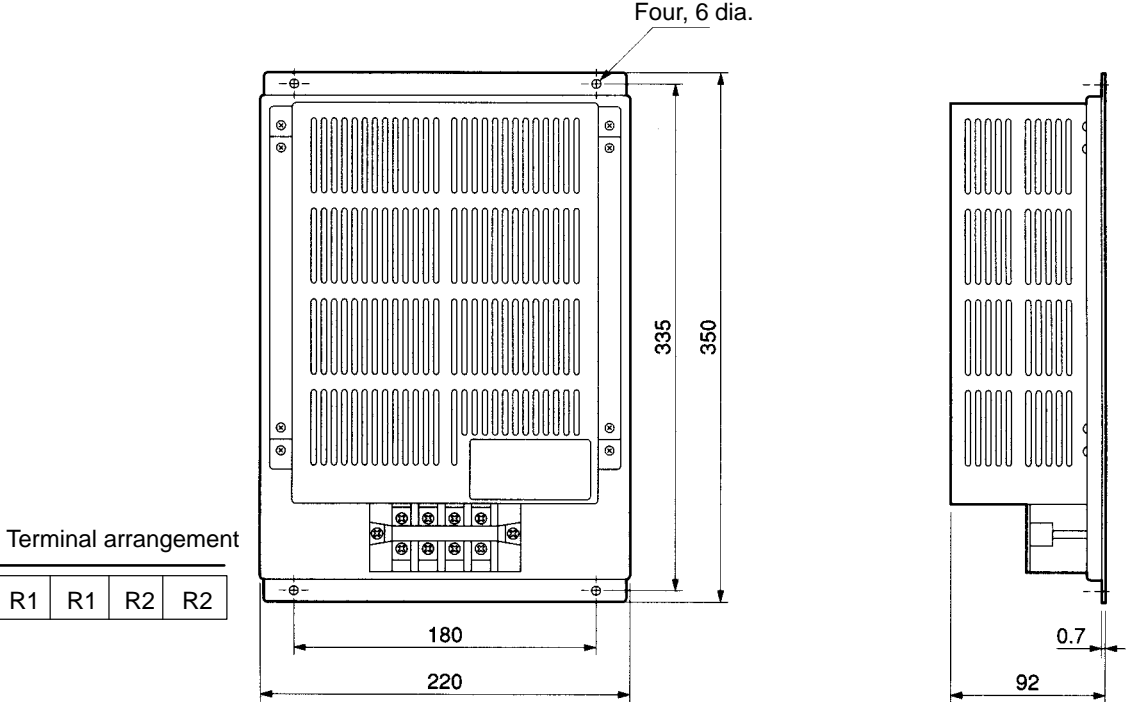

2-10 Absolute Encoder Backup Battery Specifications

A backup battery is required when using a Servomotor with an absolute encoder. Install the Battery Unit in the Servo Driver's battery holder, and connect the provided connector to the Battery Connector (CN8).

■ R88A-BAT0□W Absolute Encoder Backup Battery Unit

Model No.	Applicable Servo Driver
R88A-BAT01W	All drivers except for R88D-WT60H to R88D-WT150H
R88A-BAT02W	R88D-WT60H to R88D-WT150H

■ Specifications

Item	Specifications
Battery model number	ER3V (Toshiba)
Battery voltage	3.6 V
Current capacity	1,000 mA•h

● Connection Configuration and External Dimensions

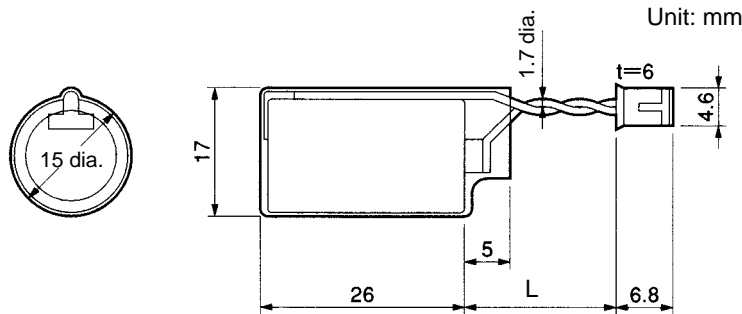

Model No.	Length (L)
R88A-BAT01W	20 mm
R88A-BAT02W	50 mm

● Wiring

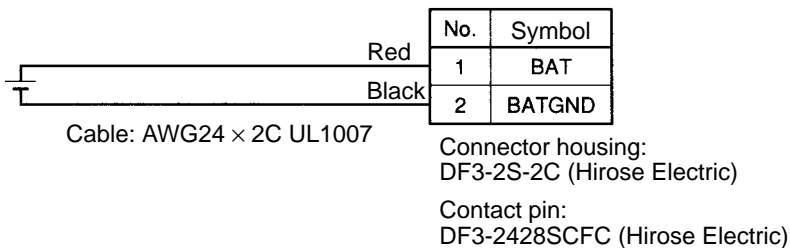

■ Manufacturing Code

A manufacturing date is indicated on the side surface of the Battery using the following code.

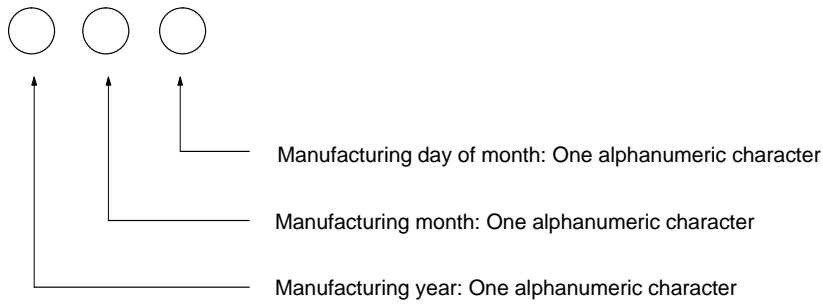

The following alphanumeric characters are used to indicate the year, month, and day of month.

Manufacturing year	Character	K	L	M	N	O	P	Q	R	S	T
	Christian year	1999	2000	2001	2002	2003	2004	2005	2006	2007	2008

Manufacturing month	Character	R	A	Y	O	L	I	T	E	S	H	U	M
	Month	1	2	3	4	5	6	7	8	9	10	11	12

Manufacturing day of month	Character	A	B	C	D	E	F	G	H	I	J	K	L
	Day of month	1	2	3	4	5	6	7	8	9	10	11	12
	Character	M	N	O	P	Q	R	S	T	U	V	W	X
	Day of month	13	14	15	16	17	18	19	20	21	22	23	24
	Character	Y	Z	2	3	4	5	6					
	Day of month	25	26	27	28	29	30	31					

Note For Batteries produced before 2000, some manufacturing codes are indicated only in two digits (i.e., year and month).

- Example 1
OMR: December 18, 2003
- Example 2
LU: November 2000

2-11 DC Reactors

Connect a DC Reactor to the Servo Driver's DC Reactor connection terminal as a harmonic current control measure. Select a model to match the Servo Driver being used. (The R88D-WT60H to R88D-WT150H models are not provided with a DC Reactor.)

■ R88A-PX□ DC Reactors

■ Specifications

Servo Driver model		DC Reactor			
		Model	Rated current (A)	Inductance (mH)	Weight (kg)
100 V	R88D-WTA3HL/A5HL/01HL	R88A-PX5063	1.8	10.0	Approx. 0.6
	R88D-WT02HL	R88A-PX5062	3.5	4.7	Approx. 0.9
200 V	R88D-WTA3H/A5H/01H	R88A-PX5071	0.85	40.0	Approx. 0.5
	R88D-WT02H	R88A-PX5070	1.65	20.0	Approx. 0.8
	R88D-WT04H	R88A-PX5069	3.3	10.0	Approx. 1.0
	R88D-WT05H/08H/10H	R88A-PX5061	4.8	2.0	Approx. 0.5
	R88D-WT15H/20H	R88A-PX5060	8.8	1.5	Approx. 1.0
	R88D-WT30H	R88A-PX5059	14.0	1.0	Approx. 1.1
	R88D-WT50H	R88A-PX5068	26.8	0.47	Approx. 1.9

■ External Dimensions

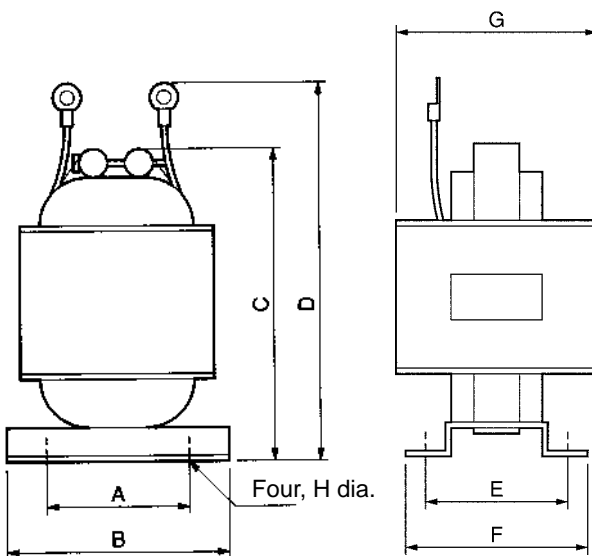

Model	A	B	C	D	E	F	G	H
R88A-PX5059	50	74	125	140	35	45	60	5
R88A-PX5060	40	59	105	125	45	60	65	4
R88A-PX5061	35	52	80	95	35	45	50	4
R88A-PX5062	40	59	100	120	40	50	55	4
R88A-PX5063	35	52	90	105	35	45	50	4
R88A-PX5068	50	74	125	155	53	66	75	5
R88A-PX5069	40	59	105	125	45	60	65	4
R88A-PX5070	40	59	100	120	35	45	50	4
R88A-PX5071	35	52	80	95	30	40	45	4

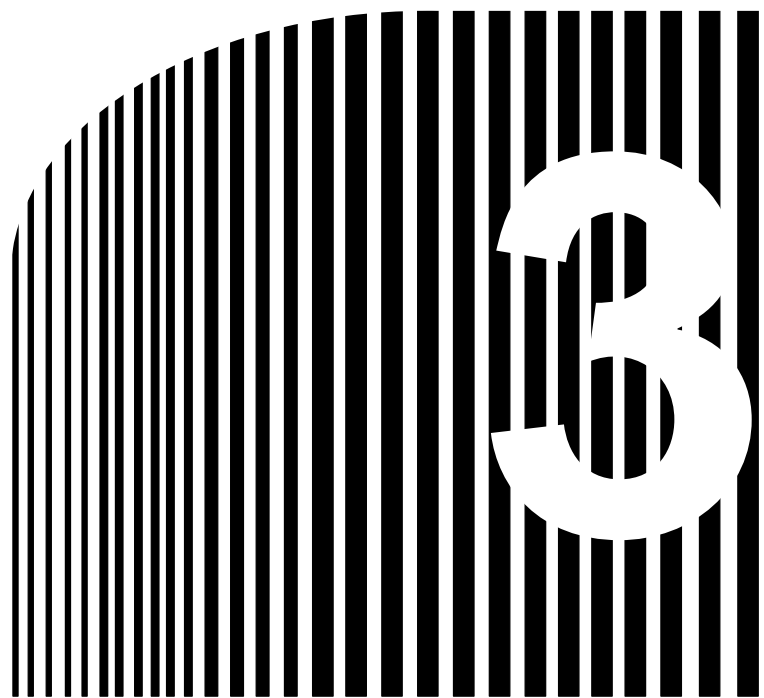













Chapter 3

- **System Design and Installation** •

- 3-1 Installation Conditions
- 3-2 Wiring
- 3-3 Regenerative Energy Absorption
- 3-4 Adjustments and Dynamic Braking When Load Inertia Is Large

Installation and Wiring Precautions

-  **Caution** Do not step on or place a heavy object on the product. Doing so may result in injury.
-  **Caution** Do not cover the inlet or outlet ports and prevent any foreign objects from entering the product. Failure to observe this may result in fire.
-  **Caution** Be sure to install the product in the correct direction. Not doing so may result in malfunction.
-  **Caution** Provide the specified clearances between the Servo Driver and the control box or other devices. Not doing so may result in fire or malfunction.
-  **Caution** Do not apply any strong impact. Doing so may result in malfunction.
-  **Caution** Be sure to wire correctly and securely. Not doing so may result in motor runaway, injury, or malfunction.
-  **Caution** Be sure that all the mounting screws, terminal screws, and cable connector screws are tightened to the torque specified in the relevant manuals. Incorrect tightening torque may result in malfunction.
-  **Caution** Use crimp terminals for wiring. Do not connect bare stranded wires directly to terminals. Connection of bare stranded wires may result in burning.
-  **Caution** Always use the power supply voltages specified in the this manual. An incorrect voltage may result in malfunctioning or burning.
-  **Caution** Take appropriate measures to ensure that the specified power with the rated voltage and frequency is supplied. Be particularly careful in places where the power supply is unstable. An incorrect power supply may result in malfunctioning.
-  **Caution** Install external breakers and take other safety measures against short-circuiting in external wiring. Insufficient safety measures against short-circuiting may result in burning.
-  **Caution** To avoid damage to the product, take appropriate and sufficient countermeasures when installing systems in the following locations:
 - Locations subject to static electricity or other sources of noise.
 - Locations subject to strong electromagnetic fields and magnetic fields.
 - Locations subject to possible exposure to radiation.
 - Locations close to power supply lines.
-  **Caution** When connecting the battery, be careful to connect the polarity correctly. Incorrect polarity connections can damage the battery or cause it to explode.

3-1 Installation Conditions

3-1-1 Servo Drivers

■ **Space Around Drivers**

- Install Servo Drivers according to the dimensions shown in the following illustration to ensure proper heat dispersion and convection inside the panel. Also install a fan for circulation if Servo Drivers are installed side by side to prevent uneven temperatures from developing inside the panel.
- Take the control cable's connector direction into account when installing the Servo Drivers.

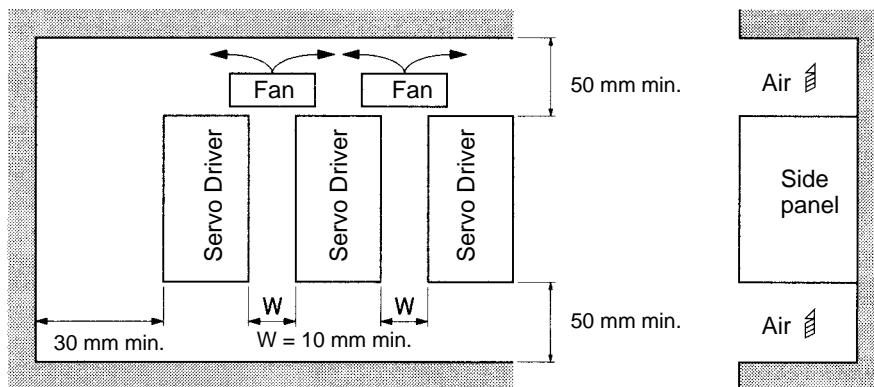

■ **Mounting Direction**

Mount the Servo Drivers in a direction (perpendicular) such that the lettering for the model number, and so on, can be seen.

■ **Operating Environment**

The environment in which Servo Drivers are operated must meet the following conditions.

- Ambient operating temperature: 0 to +55°C (Take into account temperature rises in the individual Servo Drivers themselves.)
- Ambient operating humidity: 20% to 90% (with no condensation)
- Atmosphere: No corrosive gases.

■ **Ambient Temperature**

- Servo Drivers should be operated in environments in which there is minimal temperature rise to maintain a high level of reliability.
- Temperature rise in any Unit installed in a closed space, such as a control box, will cause the ambient temperature to rise inside the entire closed space. Use a fan or a air conditioner to prevent the ambient temperature of the Servo Driver from exceeding 55°C.
- Unit surface temperatures may rise to as much as 30°C above the ambient temperature. Use heat-resistant materials for wiring, and keep separate any devices or wiring that are sensitive to heat.

- The service life of a Servo Driver is largely determined by the temperature around the internal electrolytic capacitors. The service life of an electrolytic capacitor is affected by a drop in electrolytic volume and an increase in internal resistance, which can result in overvoltage alarms, malfunctioning due to noise, and damage to individual elements. If a Servo Driver is always operated at the maximum ambient temperature of 40°C and at 80% of the rated torque, then a service life of approximately 50,000 hours can be expected. A drop of 10°C in the ambient temperature will double the expected service life.

■ Keeping Foreign Objects Out of Units

- Place a cover over the Units or take other preventative measures to prevent foreign objects, such as drill filings, from getting into the Units during installation. Be sure to remove the cover after installation is complete. If the cover is left on during operation, heat buildup may damage the Units.
- Take measures during installation and operation to prevent foreign objects such as metal particles, oil, machining oil, dust, or water from getting inside of Servo Drivers.

3-1-2 Servomotors

■ Operating Environment

The environment in which the Servomotor is operated must meet the following conditions.

- Ambient operating temperature: 0 to +40°C
- Ambient operating humidity: 20% to 80% (with no condensation)
- Atmosphere: No corrosive gases.

■ Impact and Load

- The Servomotor is resistant to impacts of up to 490 m/s². Do not subject it to heavy impacts or loads during transport, installation, or removal. When transporting it, hold onto the Servomotor itself, and do not hold onto the encoder, cable, or connector areas. Holding onto weaker areas such as these can damage the Servomotor.
- Always use a pulley remover to remove pulleys, couplings, or other objects from the shaft.
- Secure cables so that there is no impact or load placed on the cable connector areas.

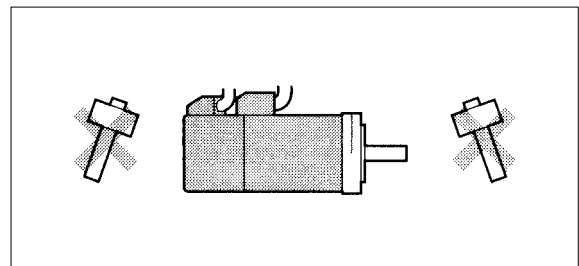

■ Connecting to Mechanical Systems

- The axial loads for Servomotors are specified in 2-5-2 Performance Specifications. If an axial load greater than that specified is applied to a Servomotor, it will reduce the service life of the motor bearings and may damage the motor shaft. When connecting to a load, use couplings that can sufficiently absorb mechanical eccentricity and variation.
- For spur gears, an extremely large radial load may be applied depending on the gear precision. Use spur gears with a high degree of accuracy (for example, JIS class 2: normal line pitch error of 6 μm max. for a pitch circle diameter of 50 mm). If the gear precision is not adequate, allow backlash to ensure that no radial load is placed on the motor shaft.
- Bevel gears will cause a load to be applied in the thrust direction depending on the structural precision, the gear precision, and temperature changes. Provide appropriate backlash or take other measures to ensure that no thrust load is applied which exceeds specifications.
- Do not put rubber packing on the flange surface. If the flange is mounted with rubber packing, the motor flange may separate due to the tightening strength.
- When connecting to a V-belt or timing belt, consult the maker for belt selection and tension. A radial load twice the belt tension will be placed on the motor shaft. Do not allow a radial load exceeding specifications to be placed on the motor shaft due to belt tension. If an excessive radial load is applied, the motor shaft may be damaged. Set up the structure so that the radial load can be adjusted. A large radial load may also be applied as a result of belt vibration. Attach a brace and adjust Servo Driver gain so that belt vibration is minimized.

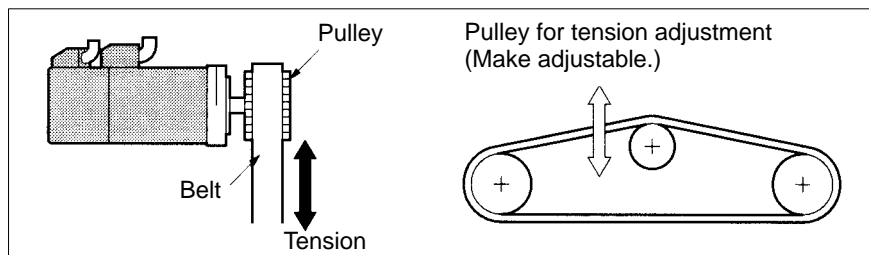
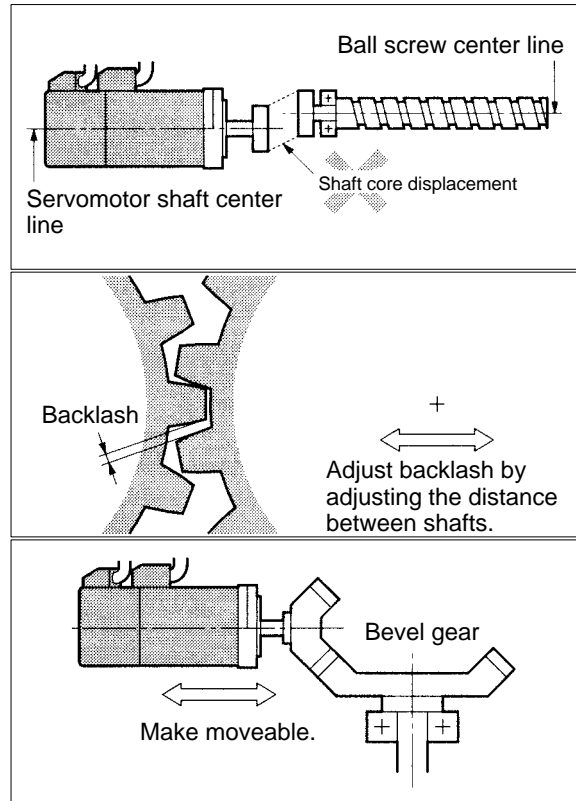

■ Connectors Conforming to EC Directives

The Power Cable and Encoder Cable connectors listed in the following table are recommended for conforming to EC Directives.

Note The connectors for the Servomotor models not listed below, i.e., 3,000-r/min Servomotors (30 to 750 W) and all 3,000-r/min Flat-style Servomotor models, already conform to EC Directives and do not need to be changed.

● **Recommended Connectors**

For Power Cables

Servomotor type		Servomotor model		Connector model	Cable clamp model	Maker
Without brake	3,000-r/min	1 kW	R88M-W1K030□-□	Angled type CE05-8A18-10SD-B-BAS Straight type CE06-6A18-10SD-B-BSS	For sheath external diameter of 6.5 to 8.7 dia.: CE3057-10A-3 (D265) For sheath external diameter of 8.5 to 11 dia.: CE3057-10A-2 (D265) For sheath external diameter of 10.5 to 14.1 dia.: CE3057-10A-1 (D265)	DDK Ltd.
		1.5 kW	R88M-W1K530□-□			
		2 kW	R88M-W2K030□-□			
	1,000-r/min	300 W	R88M-W30010□-□			
		600 W	R88M-W60010□-□			
		900 W	R88M-W90010□-□			
	1,500-r/min	450 W	R88M-W45015T-□			
		850 W	R88M-W85015T-□			
		1.3 kW	R88M-W1K315T-□			
	3,000-r/min	3 kW	R88M-W3K030□-□	Angled type JL04V-8A22-22SE-EB Straight type JL04V-6A22-22SE-EB	For sheath external diameter of 6.5 to 9.5 dia.: JL04-2022CK(09) For sheath external diameter of 9.5 to 13 dia.: JL04-2022CK(12) For sheath external diameter of 12.9 to 15.9 dia.: JL04-2022CK(14)	Japan Aviation Electronics Industry, Ltd. (JAE)
		4 kW	R88M-W4K030□-□			
		5 kW	R88M-W5K030□-□			
1,000-r/min	1.2 kW	R88M-W1K210□-□				
	2 kW	R88M-W2K010□-□				
	3 kW	R88M-W3K010□-□				
1,500-r/min	1.8 kW	R88M-W1K815T-□				
	2.9 kW	R88M-W2K915T-□				
	4.4 kW	R88M-W4K415T-□				
1,000-r/min	4 kW	R88M-W4K010□-□	Angled type JL04V-8A32-17SE	(Use a conduit.)	Japan Aviation Electronics Industry, Ltd. (JAE)	
	5.5 kW	R88M-W5K510□-□				
1,500-r/min	5.5 kW	R88M-W5K515T-B□	Straight type JL04V-6A32-17SE			
	7.5 kW	R88M-W7K515T-B□				
	11 kW	R88M-W11K015T-□				
		15 kW	R88M-W15K015T-□			

Servomotor type		Servomotor model		Connector model	Cable clamp model	Maker		
With brake	3,000-r/min	1 kW	R88M-W1K030□-B□	Angled type JL04V-8A20-15SE-EB Straight type JL04V-6A20-15SE-EB	For sheath external diameter of 6.5 to 9.5 dia.: JL04-2022CK(09) For sheath external diameter of 9.5 to 13 dia.: JL04-2022CK(12) For sheath external diameter of 12.9 to 15.9 dia.: JL04-2022C K(14)	Japan Aviation Electronics Industry, Ltd. (JAE)		
		1.5 kW	R88M-W1K530□-B□					
		2 kW	R88M-W2K030□-B□					
	1,000-r/min	300 W	R88M-W30010□-B□					
		600 W	R88M-W60010□-B□					
		900 W	R88M-W90010□-B□					
	1,500-r/min	450 W	R88M-W45015T-B□					
		850 W	R88M-W85015T-B□					
		1.3 kW	R88M-W1K315T-B□					
	3,000-r/min	3 kW	R88M-W3K030□-B□	Angled type JL04V-8A24-10SE-EB Straight type JL04V-6A24-10SE-EB	For sheath external diameter of 9 to 12 dia.: JL04-2428CK(11) For sheath external diameter of 12 to 15 dia.: JL04-2428CK(14) For sheath external diameter of 15 to 18 dia.: JL04-2428CK(17) For sheath external diameter of 18 to 20 dia.: JL04-2428CK(20)		Japan Aviation Electronics Industry, Ltd. (JAE)	
		4 kW	R88M-W4K030□-B□					
		5 kW	R88M-W5K030□-B□					
	1,000-r/min	1.2 kW	R88M-W1K210□-B□					
		2 kW	R88M-W2K010□-B□					
		3 kW	R88M-W3K010□-B□					
1,500-r/min	1.8 kW	R88M-W1K815T-B□						
	2.9 kW	R88M-W2K915T-B□						
	4.4 kW	R88M-W4K415T-B□						
1,000-r/min (See note.)	4 kW	R88M-W4K010□-B□	(For power connector) Angled type JL04V-8A32-17SE Straight type JL04V-6A32-17SE			(Use a conduit.)		Japan Aviation Electronics Industry, Ltd. (JAE)
	5.5 kW	R88M-W5K510□-B□						
1,500-r/min	5.5 kW	R88M-W5K515T-B□						
	7.5 kW	R88M-W7K515T-B□						
	11 kW	R88M-W11K015T-B□						
	15 kW	R88M-W15K015T-B□						
				(For brake connector) Angled type MS3108A10SL-3S (D190): Plug CE-10SLBA-S: Back shell Straight type MS3108A10SL-3S (D190): Plug CE-10SLBS-S: Back shell	For sheath external diameter of 5 to 8 dia.: CE3057-4A-1		DDK Ltd.	

Note For 4-kW and 5.5-kW (1,000-r/min) Servomotors and 5.5- to 15-kW (1,500-r/min) Servomotors, there are separate connectors for power and brakes. Therefore, when a Servomotor with a brake is used, it will require both a Power Cable for a Servomotor without a brake and a Power Cable for a Servomotor with a brake.

For Encoder Cables

Servomotor type	Servomotor model	Connector model	Cable clamp model	Maker
3,000-r/min (1 to 5 kW)	R88M-W1K030□-□ to R88M-W5K030□-□	Angled type JA08A-20-29S-J1-EB Straight type JA06A-20-29S-J1-EB	For sheath external diameter of 6.5 to 9.5 dia.: JL04-2022CKE(09)	Japan Aviation Electronics Industry, Ltd. (JAE)
1,000-r/min (300 W to 5.5 kW)	R88M-W30010□-□ to R88M-W5K510□-□		For sheath external diameter of 9.5 to 13 dia.: JL04-2022CKE(12)	
1,500-r/min (450 W to 15 kW)	R88M-W45015T-□ to R88M-W15K015T-□		For sheath external diameter of 12.9 to 16 dia.: JL04-2022CKE(14)	

■ **Water and Drip Resistance**

The enclosure ratings for the Servomotors are as follows:

3,000-r/min Servomotors (30 to 750 W): IP55 (except for through-shaft parts).

3,000-r/min Servomotors (1 to 5 kW): IP67 (except for through-shaft parts). Models are also available with IP67 ratings that include through-shaft parts.

3,000-r/min Flat-style Servomotors (100 W to 1.5 kW): IP55 (except for through-shaft parts). Models are also available with IP67 ratings that include through-shaft parts.

1,000-r/min Servomotors (300 W to 5.5 kW): IP67 (except for through-shaft parts). Models are also available with IP67 ratings that include through-shaft parts.

1,500-r/min Servomotors (450 W to 15 kW): IP67 (except for through-shaft parts). Models are also available with IP67 ratings that include through-shaft parts.

The standard cable conforms to IP30. When selecting an IP67-rated Servomotor for use in a wet environment, install waterproof connectors for the power and Encoder Cables. The recommended connectors are the same as for the EC Directives, listed in the tables above.

■ Oil Seals

If the Servomotor is to be used in a location where it may be exposed to oil or grease, select an IP67-rated Servomotor or a Servomotor with an oil seal.

■ Other Precautions

- Do not apply commercial power directly to the Servomotor. The Servomotors run on synchronous AC and use permanent magnets. Applying commercial power directly will burn out the motor coils.
- Take measures to prevent the shaft from rusting. The shafts are coated with anti-rust oil when shipped, but anti-rust oil or grease should also be applied when connecting the shaft to a load.
- Absolutely do not remove the encoder cover or take the motor apart. The magnet and the encoder are aligned in the AC Servomotor. If they become misaligned, the motor will not operate.

3-2 Wiring

3-2-1 Connecting Cable

This section shows the types of connecting cable used in an OMNUC W-series servo system. The wide selection of cables provided for configuring a servo system using a Motion Control Unit or Position Unit makes wiring simple.

■ Servo System Configuration

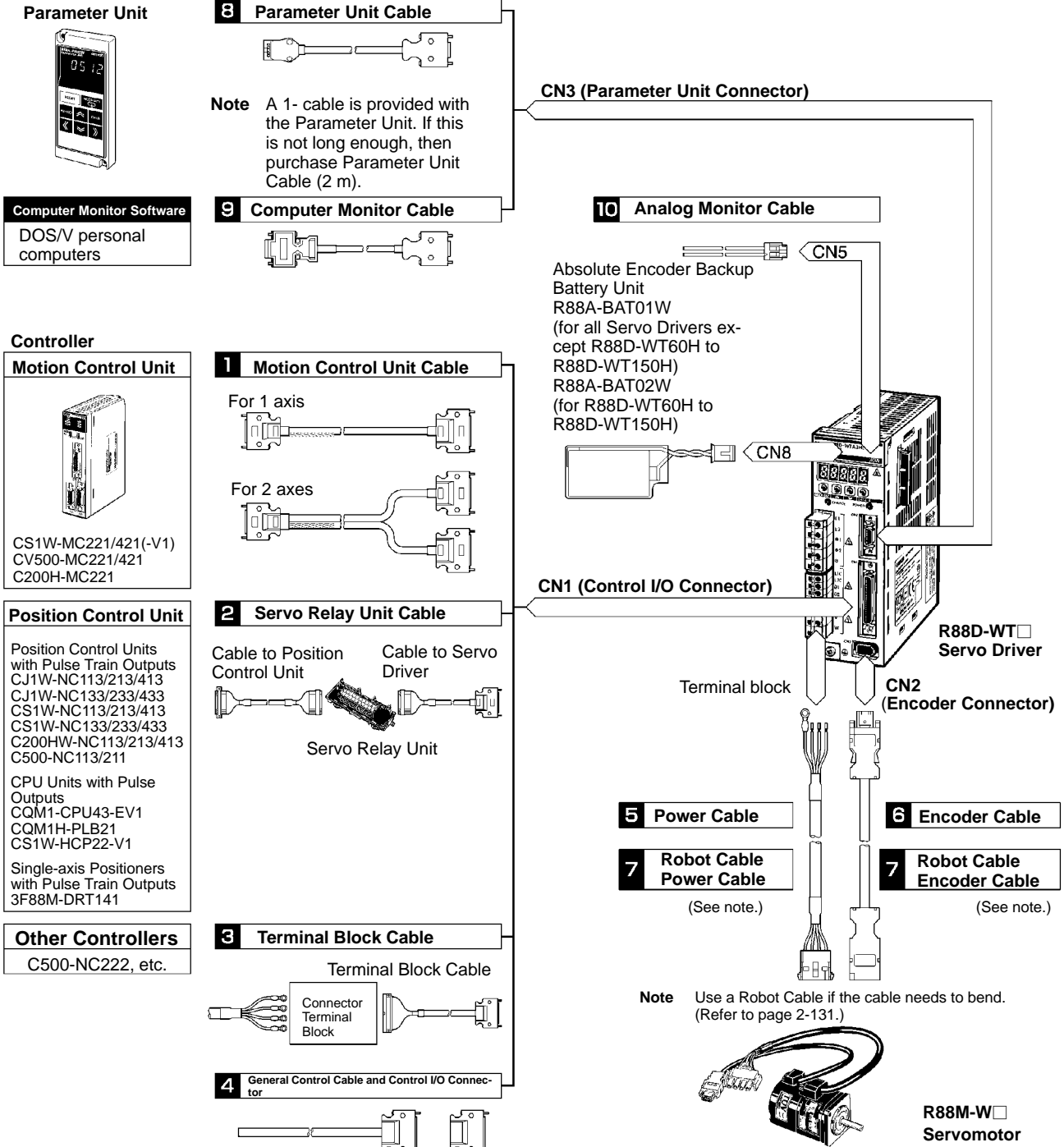

■ **Selecting Connecting Cables**

1. Motion Control Unit Cable

There are special cables for 1-axis and 2-axis Motion Control Unit operation. Select the appropriate cable for the number of axes to be connected.

Motion Control Unit	Cable	Remarks
CS1W-MC221/421(-V1) CV500-MC221/421 C200H-MC221	For 1 axis	R88A-CPW□□□M1
	For 2 axes	R88A-CPW□□□M2
		The empty boxes in the model numbers are for cable length. The cables can be 1, 2, 3, or 5 meters long. (For example, R88A-CPW002M1 is for one axis and is 2 meters long.)

2. Servo Relay Unit Cable

Select a Servo Relay Unit and Cable to match the Position Control Unit that is to be used.

Position Control Unit	Cable to Position Control Unit	Servo Relay Unit	Cable to Servo Driver
C500-NC113	XW2Z-□□□J-A2	XW2B-40J6-2B	XW2Z-□□□J-B4
C500-NC211			
CQM1-CPU43-EV1	XW2Z-□□□J-A3	XW2B-20J6-3B	
CQM1H-PLB21			
CS1W-NC113	XW2Z-□□□J-A6	XW2B-20J6-1B	
C200HW-NC113			
CS1W-NC213	XW2Z-□□□J-A7	XW2B-40J6-2B	
CS1W-NC413			
C200HW-NC213			
C200HW-NC413			
CS1W-NC133	XW2Z-□□□J-A10	XW2B-20J6-1B	
CS1W-NC233	XW2Z-□□□J-A11	XW2B-40J6-2B	
CS1W-NC433			
CJ1W-NC113	XW2Z-□□□J-A14	XW2B-20J6-1B	
CJ1W-NC213	XW2Z-□□□J-A15	XW2B-40J6-2B	
CJ1W-NC413			
CJ1W-NC133	XW2Z-□□□J-A18	XW2B-20J6-1B	
CJ1W-NC233	XW2Z-□□□J-A19	XW2B-40J6-2B	
CJ1W-NC433			
CS1W-HCP22-V1	XW2Z-□□□J-A22 (for 1 axis)	XW2B-20J6-3B	
	XW2Z-□□□J-A23 (for 2 axes)		
3F88M-DRT141	XW2Z-□□□J-A24	XW2B-20J6-1B	

Note 1. The empty boxes in the model numbers are for cable length. The cables can be 0.5 or 1 meter long. (For example, XW2Z-050J-A1 is 0.5 meter long.)

Note 2. When 2-axis control is used with C200HW-NC213, C200HW-NC413, C200H-NC211, or C500-NC211 Position Control Units, two cables are required to the Servo Driver.

3. Connector-Terminal Block Cables

These cables are used for connecting to Controllers for which no special cable is provided. The cables and terminal block convert the Servo Driver's Control I/O Connector (CN1) signals to terminal block connections.

Connector Terminal Block	Cable	Remarks
XW2B-50G5	R88A-CTW□□□N	The empty boxes in the model numbers are for cable length. The cables can be 1 or 2 meters long. (For example, R88A-CTW002N is 2 meters long.)

4. General Control Cable and Control I/O Connector

These cables and connector are used for connecting to Controllers for which no special cable is provided, and when the cable for the Servo Driver's control I/O connector is prepared by the user.

Name	Cable	Remarks
General Control Cable	R88A-CPW□□□S	The cable is attached to a connector that connects to the Control I/O Connector (CN1). The empty boxes in the model numbers are for cable length. The cables can be 1 or 2 meters long. (For example, R88A-CPW001S is 1 meter long.)
Control I/O Connector	R88A-CNU11C	This is the connector for connecting to the Control I/O Connector (CN1). (This item is a connector only.)

5. Power Cable

Select a Power Cable to match the Servomotor that is to be used.

Servomotor type		Power Cables for Servomotors Without Brakes	Power Cables for Servomotors With Brakes
3,000-r/min Servomotors	30 to 750 W	R88A-CAWA□□□S	R88A-CAWA□□□B
	1 to 2 kW	R88A-CAWC□□□S	R88A-CAWC□□□B
	3 to 5 kW	R88A-CAWD□□□S	R88A-CAWD□□□B
3,000-r/min Flat-style Servomotors	100 to 750 W	R88A-CAWA□□□S	R88A-CAWA□□□B
	1.5 kW	R88A-CAWB□□□S	R88A-CAWB□□□B
1,000-r/min Servomotors	300 to 900 W	R88A-CAWC□□□S	R88A-CAWC□□□B
	1.2 to 3 kW	R88A-CAWD□□□S	R88A-CAWD□□□B
	4 kW	R88A-CAWE□□□S	R88A-CAWE□□□S (For Power Connector) R88A-CAWE□□□B (For Brake Connector)
	5.5 kW	R88A-CAWF□□□S	R88A-CAWF□□□S (For Power Connector) R88A-CAWE□□□B (For Brake Connector)

Servomotor type		Power Cables for Servomotors Without Brakes	Power Cables for Servomotors With Brakes
1,500-r/min Servomotors	450 W to 1.3 kW	R88A-CAWC□□□S	R88A-CAWC□□□B
	1.8 to 4.4 kW	R88A-CAWD□□□S	R88A-CAWD□□□B
	5.5 kW	R88A-CAWE□□□S	R88A-CAWE□□□S (For Power Connector) R88A-CAWE□□□B (For Brake Connector)
	7.5 to 11 kW	R88A-CAWF□□□S	R88A-CAWF□□□S (For Power Connector) R88A-CAWE□□□B (For Brake Connector)
	15 kW	(Made by customer.)	(Make the cable for the Power Connector.) R88A-CAWE□□□B (For Brake Connector)

- Note 1.** The empty boxes in the model numbers are for cable length. The cables can be 3, 5, 10, 15, 20, 30, 40, or 50 meters long. (For example, R88A-CAWA003S is 3 meters long.)
- Note 2.** For 4-kW and 5.5-kW (1,000-r/min) Servomotors, and 5.5-kW and higher (1,500-r/min) Servomotors, there are separate connectors for power and brakes. Therefore, when a Servomotor with a brake is used, it will require both a Power Cable for a Servomotor without a brake and a Power Cable for a Servomotor with a brake.
- Note 3.** For 750-W Servomotors, use R88A-CAWB□ Power Cable if the wiring distance will be 30 meters or more.
- Note 4.** A Power Cable is not provided for 15-kW (1,500-r/min) Servomotors. Refer to *Power Cable for 1,500-r/min Servomotors* under 3-2-3 Terminal Block Wiring, and make the power cable.

6. Encoder Cable

Select an Encoder Cable to match the Servomotor that is to be used.

Servomotor type		Encoder Cable	Remarks
3,000-r/min Servomotors	30 to 750 W	R88A-CRWA□□□C	The empty boxes in the model numbers are for cable length. The cables can be 3, 5, 10, 15, 20, 30, 40, or 50 meters long. (For example, R88A-CRWA003C is 3 meters long.)
	1 to 5 kW	R88A-CRWB□□□N	
3,000-r/min Flat-style Servomotors	100 W to 1.5 kW	R88A-CRWA□□□C	
1,000-r/min Servomotors	300 W to 5.5 kW	R88A-CRWB□□□N	
1,500-r/min Servomotors	450 W to 15 kW	R88A-CRWB□□□N	

7. Robot Cable

Use a Robot Cable if the encoder or power cables need to bend.

• Encoder Cables

Motor		Encoder Cable	Remarks
3,000-r/min Servomotors	30 to 750 W	R88A-CRWA□□□CR	The “□□□” in the model number indicates the cable length.
	1 to 5 kW	R88A-CRWB□□□NR	
3,000-r/min Flat-style Servomotors	100 to 1.5 kW	R88A-CRWA□□□CR	There are 8 cable lengths: 3 m, 5 m, 10 m, 15 m, 20 m, 30 m, 40 m, and 50 m. (Example model number: R88A-CRWA003CR (3 m))
1,000-r/min Servomotors	300 to 5.5 kW	R88A-CRWB□□□NR	
1,500-r/min Servomotors	450 W to 15 kW	R88A-CRWB□□□NR	

• Power Cables

Motor		Power Cable for Motors Without Brakes	Power Cable for Motors With Brakes
3,000-r/min Servomotors	30 to 750 W	R88A-CAWA□□□SR	R88A-CAWA□□□BR
	1 to 2 kW	R88A-CAWC□□□SR	R88A-CAWC□□□BR
	3 to 5 kW	R88A-CAWD□□□SR	R88A-CAWD□□□BR
3,000-r/min Flat-style Servomotors	100 to 750 W	R88A-CAWA□□□SR	R88A-CAWA□□□BR
	1.5 kW	R88A-CAWB□□□SR	R88A-CAWB□□□BR
1,000-r/min Servomotors	300 to 900 W	R88A-CAWC□□□SR	R88A-CAWC□□□BR
	1.2 to 3 kW	R88A-CAWD□□□SR	R88A-CAWD□□□BR
1,500-r/min Servomotors	450 W to 1.3 kW	R88A-CAWC□□□SR	R88A-CAWC□□□BR
	1.8 to 4.4 kW	R88A-CAWD□□□SR	R88A-CAWD□□□BR

Note The “□□□” in the model number indicates the cable length. There are 8 cable lengths: 3 m, 5 m, 10 m, 15 m, 20 m, 30 m, 40 m, and 50 m.
(Example model number: R88A-CAWA003SR (3 m))

8. Parameter Unit Cable

With OMNUC W-series Servo Drivers, parameter settings and Servo Driver monitoring can be carried out using the display and settings areas on the front panel of the Servo Driver. A Parameter Unit (R88A-PR02W) is required in order to perform these operations at a distance from the Servo Driver, or using a control box. If the 1-meter cable provided with the Parameter Unit is not long enough, then replace it with 2-meter Parameter Unit Cable.

Note If this cable is connected to an OMNUC U-series Hand-held Parameter Unit (R88A-PR02U), that Unit can be used as a W-series Parameter Unit.

Name/specifications	Model	Remarks
Parameter Unit Cable	2 m R88A-CCW002C	Only 2-meter cables are available.

9. Computer Monitor Cable

A Computer Monitor Cable and the OMNUC W-series Computer Monitor Software for Servo Drivers (run on Windows) are required to make Servo Driver parameter settings and perform monitoring from a personal computer.

Name/specifications	Model	Remarks
Computer Monitor Cable	For DOS personal computers 2 m R88A-CCW002P2	Only 2-meter cables are available.

10. Analog Monitor Cable

This is the cable for connecting to the Servo Driver’s Analog Monitor Connector (CN5). It is required for connecting analog monitor outputs to an external device (such as a measuring instrument).

Name/specifications		Model	Remarks
Analog Monitor Cable	1 m	R88A-CMW001S	Only 1-meter cables are available.

3-2-2 Peripheral Device Connection Examples

■ R88D-WTA3HL/-WTA5HL/-WT01HL/-WT02HL/-WTA3H/-WTA5H/-WT01H/-WT02H/-WT04H

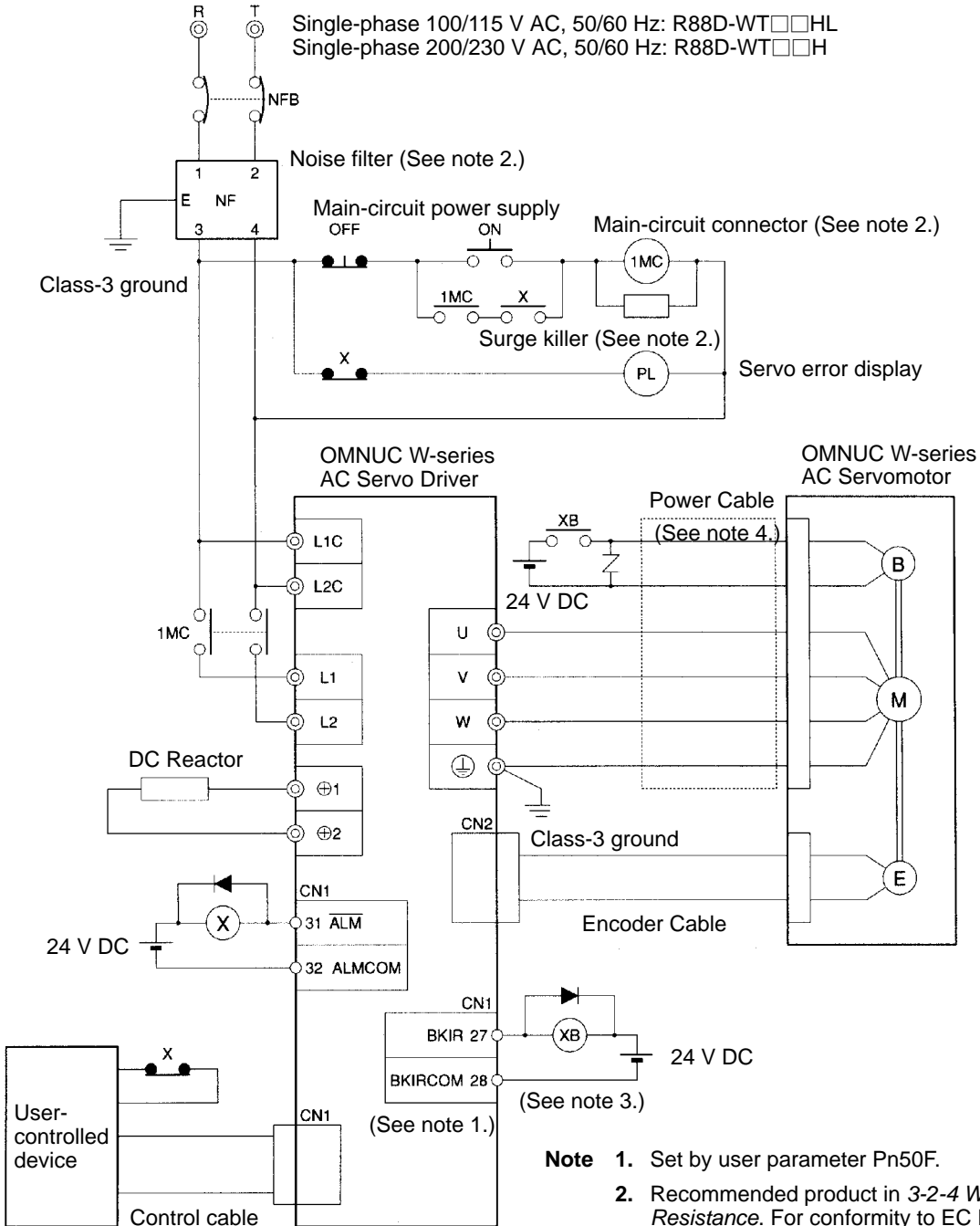

- Note**
1. Set by user parameter Pn50F.
 2. Recommended product in 3-2-4 *Wiring for Noise Resistance*. For conformity to EC Directives, refer to 3-2-5 *Wiring for Conformity to EMC Directives*.
 3. Recommended relay: MY Relay (24 V), by OMRON. For example, an MY2 Relay outputs to a 2-A inductive load at 24 V DC, making it applicable to all W-series Motors with Brakes.
 4. The brake is not affected by the polarity of the power supply.

■ R88D-WT05H/-WT08H/-WT10H/-WT15H/-WT20H/-WT30H/-WT50H/-WT60H/-WT75H/-WT150H

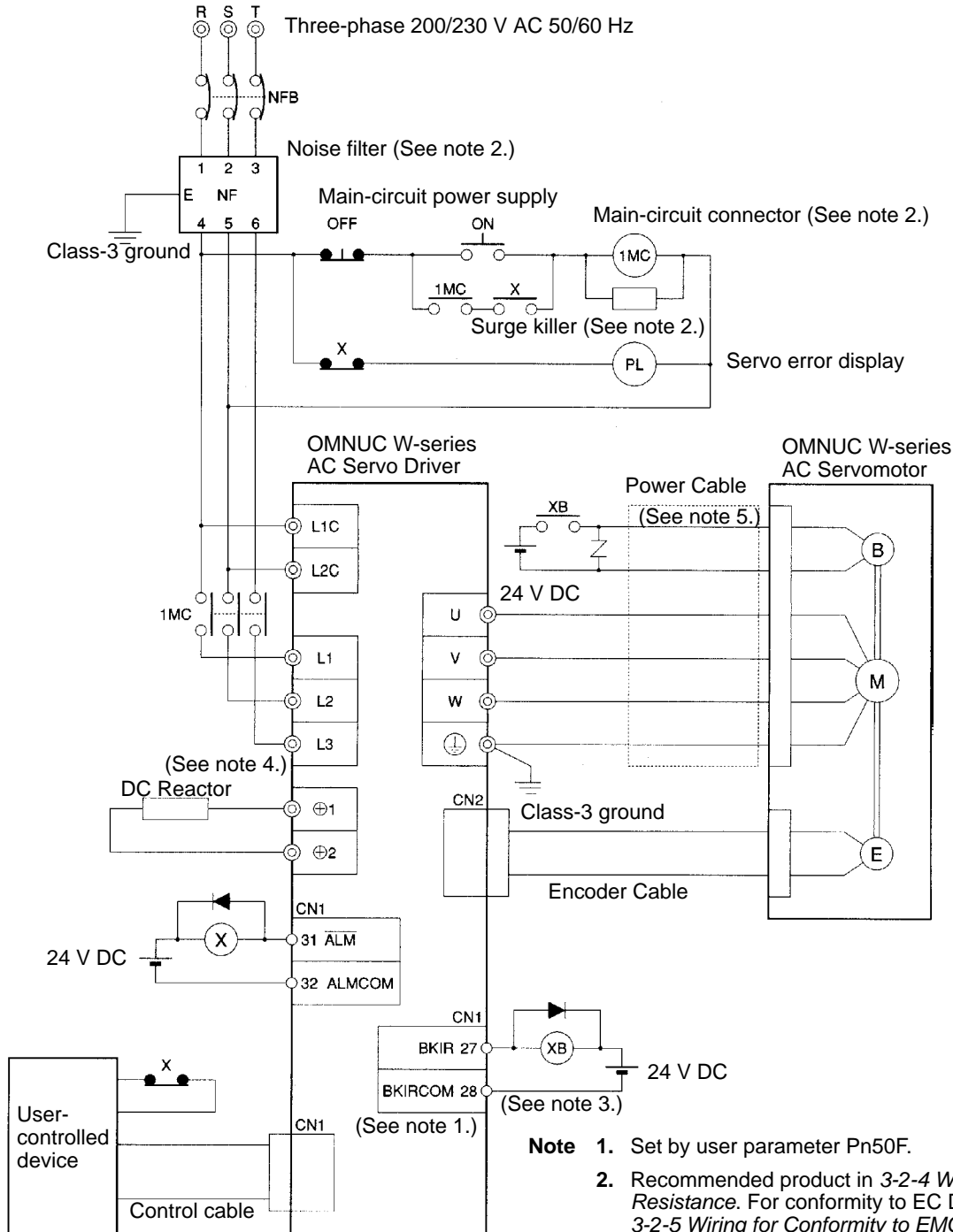

- Note**
1. Set by user parameter Pn50F.
 2. Recommended product in 3-2-4 *Wiring for Noise Resistance*. For conformity to EC Directives, refer to 3-2-5 *Wiring for Conformity to EMC Directives*.
 3. Recommended relay: MY relay (24 V), by OMRON. For example, an MY2 Relay outputs to a 2-A inductive load at 24 V DC, making it applicable to all W-series Motors with Brakes.
 4. Refer to 6-3 *Single-phase Power for 3,000-r/min (750-W) Servomotors* when using an R88D-WT08H with single-phase 200-V power supply.
 5. The brake is not affected by the polarity of the power supply.

3-2-3 Terminal Block Wiring

When wiring a Terminal Block, pay attention to wire sizes, grounding systems, and anti-noise measures.

■ Terminal Block Names and Functions

Terminal label	Name	Function	
L1	Main circuit power supply input	R88D-WT□H (30 to 400 W) Single-phase 200/230 V AC (170 to 253 V), 50/60 Hz	
L2		R88D-WT□H (500 W to 6 kW) Three-phase 200/230 V AC (170 to 253 V), 50/60 Hz	
L3		R88D-WT□HL (30 to 200 W) Single-phase 100/115 V AC (85 to 127 V), 50/60 Hz	
⊕	Main circuit DC output (positive)	Do not connect anything to these terminals. (Only the R88D-WT60H, R88D-WT75H, and R88D-WT150H have this terminal.)	
⊕1	Connection terminals for DC Reactor for power supply harmonic control	Normally short between ⊕1 and ⊕2. When harmonic control measures are required, connect a DC Reactor between ⊕1 and ⊕2.	
⊕2		(The R88D-WT60H, R88D-WT75H, and R88D-WT150H do not have these terminals.)	
⊖	Main circuit DC output (negative)	Do not connect anything to these terminals.	
L1C	Control circuit power supply input	R88D-WT□H Single-phase 200/230 V AC (170 to 253 V), 50/60 Hz	
L2C		R88D-WT□HL Single-phase 100/115 V AC (85 to 127 V), 50/60 Hz	
B1	External regeneration resistance connection terminal	30 to 400 W: These terminals normally do not need to be connected. If there is high regenerative energy, connect an External Regeneration Resistor between B1 and B2.	
B2		500 W to 5 kW: Normally short between B2 and B3. If there is high regenerative energy, remove the short bar between B2 and B3 and connect an External Regeneration Resistor between B1 and B2.	
B3		6 to 15 kW: Connect an External Regeneration Resistance Unit between B1 and B2.	
U	Servomotor connection terminals	Red	These are the output terminals to the Servomotor. Be careful to wire them correctly.
V		White	
W		Blue	
⊕		Green/ Yellow	
⊕	Frame ground	This is the ground terminal. Ground to a 100 Ω or less.	

■ Terminal Block Wire Sizes

● 100-V AC Input (R88D-WT□HL)

Item	Model Unit	R88D-WTA3HL	R88D-WTA5HL	R88D-WT01HL	R88D-WT02HL	
Power supply capacity	kVA	0.15	0.25	0.4	0.6	
Main circuit power supply input (L1, L2) (See note 1.)	Rated current	A (rms)	1.1	1.8	3.0	5.2
	Wire size	mm ²	1.25	1.25	1.25	2
	Screw size	–	–	–	–	–
	Torque	N•m	–	–	–	–
Control circuit power supply input (L1C, L2C)	Rated current	A (rms)	0.13	0.13	0.13	0.13
	Wire size	mm ²	1.25	1.25	1.25	1.25
	Screw size	–	–	–	–	–
	Torque	N•m	–	–	–	–
Servomotor connection terminal (U, V, W, ⊕) (See note 2.)	Rated current	A (rms)	0.66	0.95	2.4	3.0
	Wire size	mm ²	1.25	1.25	1.25	1.25
	Screw size	–	–	–	–	–
	Torque	N•m	–	–	–	–
Frame ground (⊕)	Wire size	mm ²	2	2	2	2
	Screw size	–	M4	M4	M4	M4
	Torque	N•m	1.2	1.2	1.2	1.2

Note 1. Use the same wire sizes for ⊕1, ⊕2, B1, and B2.

Note 2. Connect special OMRON Power Cable to the Servomotor connection terminals.

● 200-V AC Input (R88D-WT□H)

Item	Model Unit	R88D-WTA3H	R88D-WTA5H	R88D-WT01H	R88D-WT02H	R88D-WT04H	R88D-WT05H	R88D-WT08H	R88D-WT10H	R88D-WT15H	R88D-WT20H	R88D-WT30H	R88D-WT50H	R88D-WT60H	R88D-WT75H	R88D-WT150H	
Power supply capacity	kVA	0.2	0.25	0.4	0.75	1.2	1.4	1.9	2.3	3.2	4.3	5.9	7.5	12.5	15.5	30.9	
Main circuit power supply input (L1, L2 or L1, L2, L3) (See note 1.)	Rated current	A (rms)	0.8	1.1	2.0	3.4	5.5	4.0	5.4	7.0	9.5	12.0	17.0	24.0	32.0	41.0	81.0
	Wire size	mm ²	1.25	1.25	1.25	1.25	2	2	2	2	3.5	3.5	5.5	8	14	22	
	Screw size	–	–	–	–	–	–	–	–	–	–	M4	M4	M5	M6	M6	M8
	Torque	N•m	–	–	–	–	–	–	–	–	–	1.2	1.2	2	2.5	2.5	6
Control circuit power supply input (L1C, L2C)	Rated current	A (rms)	0.13	0.13	0.13	0.13	0.13	0.15	0.15	0.15	0.15	0.15	0.15	0.15	0.27	0.27	0.30
	Wire size	mm ²	1.25	1.25	1.25	1.25	1.25	1.25	1.25	1.25	1.25	1.25	1.25	1.25	1.25	1.25	1.25
	Screw size	–	–	–	–	–	–	–	–	–	–	M4	M4	M4	M4	M4	M4
	Torque	N•m	–	–	–	–	–	–	–	–	–	1.2	1.2	1.2	1.2	1.2	1.2
Servomotor connection terminal (U, V, W, ⊕) (See note 2.)	Rated current	A (rms)	0.44	0.64	0.91	2.1	2.8	3.8	5.7	7.6	11.6	18.5	24.8	32.9	46.9	54.7	7.8
	Wire size	mm ²	1.25	1.25	1.25	1.25	1.25	2	2	3.5	3.5	3.5	5.5	8	14	14	22
	Screw size	–	–	–	–	–	–	–	–	–	–	M4	M4	M5	M6	M6	M8
	Torque	N•m	–	–	–	–	–	–	–	–	–	1.2	1.2	2	2.5	2.5	6
Frame ground (⊕)	Wire size	mm ²	2	2	2	2	2	2	2	2	2	2	2	2	2	2	2
	Screw size	–	M4	M4	M4	M4	M4	M4	M4	M4	M4	M4	M4	M4	M8	M8	M8
	Torque	N•m	1.2	1.2	1.2	1.2	1.2	1.2	1.2	1.2	1.2	1.2	1.2	1.2	6	6	6

Note 1. Use the same wire sizes and tightening torques for ⊕1, ⊕2, B1, and B2.

Note 2. Connect special OMRON Power Cable to the Servomotor connection terminals.

■ Wire Sizes and Allowable Current

The following table shows the allowable current for when there are three wires.

● 600-V Heat-resistant Vinyl Wiring (HIV) (Reference Values)

AWG size	Nominal cross-sectional area (mm ²)	Configuration (wires/mm ²)	Conductive resistance (Ω/km)	Allowable current (A) for ambient temperature		
				30°C	40°C	50°C
20	0.5	19/0.18	39.5	6.6	5.6	4.5
–	0.75	30/0.18	26.0	8.8	7.0	5.5
18	0.9	37/0.18	24.4	9.0	7.7	6.0
16	1.25	50/0.18	15.6	12.0	11.0	8.5
14	2.0	7/0.6	9.53	23	20	16
12	3.5	7/0.8	5.41	33	29	24
10	5.5	7/1.0	3.47	43	38	31
8	8.0	7/1.2	2.41	55	49	40
6	14.0	7/1.6	1.35	79	70	57
4	22.0	7/2.0	0.849	99	88	70

■ Terminal Block Wiring Procedure

Connector-type Terminal Blocks are used for Servo Drivers of 1.5 W or less (R88D-WTA3H□ to R88D-WT15H). The procedure for wiring these Terminal Blocks is explained below.

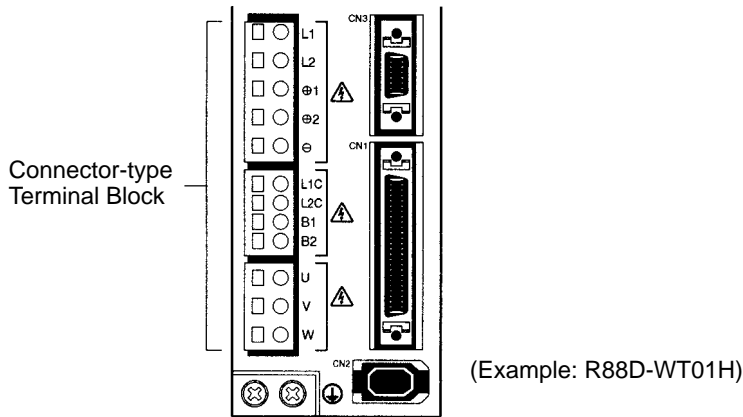

1. Remove the Terminal Block from the Servo Driver.

Caution The Terminal Block must be removed from the Servo Driver before being wired. The Servo Driver will be damaged if the wiring is done with the Terminal Block in place.

2. Strip the covering off the ends of the wires.

Prepare wires of the right sizes, according to the tables provided under *Terminal Block Wire Sizes* above, and strip off 8 or 9 mm of the covering from the end of each wire.

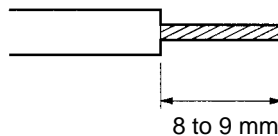

3. Open the wire insertion slots in the Terminal Block

There are two ways to open the wire insertion slots, as follows:

- Pry the slot open using the lever that comes with the Servo Driver (as in Fig. A).
- Insert a flat-blade screwdriver (end width: 3.0 to 3.5 mm) into the opening for Servo Driver installation, and press down firmly to open the slot (as in Fig. B).

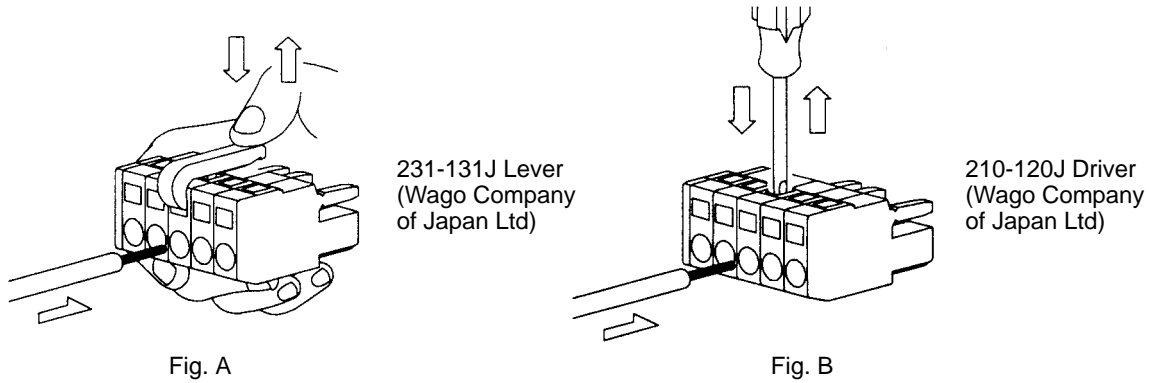

4. Insert the wire into the slot.

With the slot held open, insert the end of the wire. Then let the slot close by releasing the pressure from the lever or the screwdriver.

5. Mount the Terminal Block to the Servo Driver.

After all of the terminals have been wired, return the Terminal Block to its original position on the Servo Driver.

■ Power Cable for 1,500-r/min Servomotors

When using a 15-kW Servomotor (R88M-W15K015T-□), make a Power Cable as shown below to connect the Servomotor and Servo Driver.

● Connection Configuration and External Dimensions

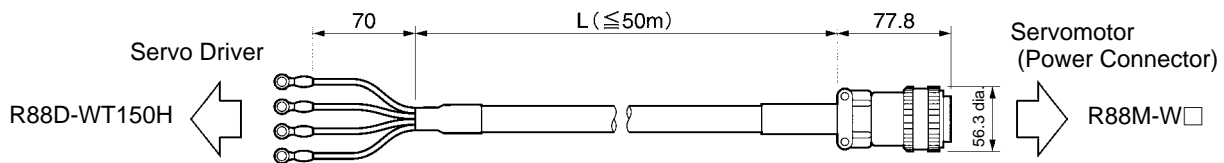

● Wiring

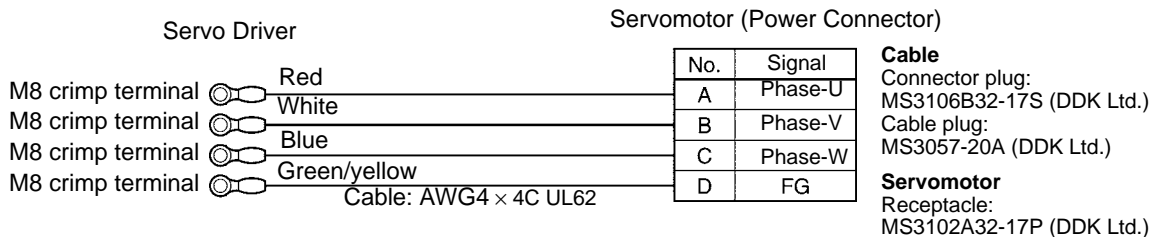

Note 1. The maximum cable distance between the Servomotor and Servo Driver is 50 m.

Note 2. For Servomotors with brakes, there are separate connectors for power and brakes. Therefore, whenever a Servomotor with a brake is used, a separate R88A-CAWE□B Power Cable is required. R88A-CAWE□B Power Cable is used for wiring (2-core) the brake line only.

3-2-4 Wiring for Noise Resistance

System noise resistance will vary greatly depending on the wiring method used. This section explains how to reduce noise through proper wiring.

■ Wiring Method

● R88D-WTA3H□ to R88D-WT04H Servo Drivers (Single-phase Power Supply Input)

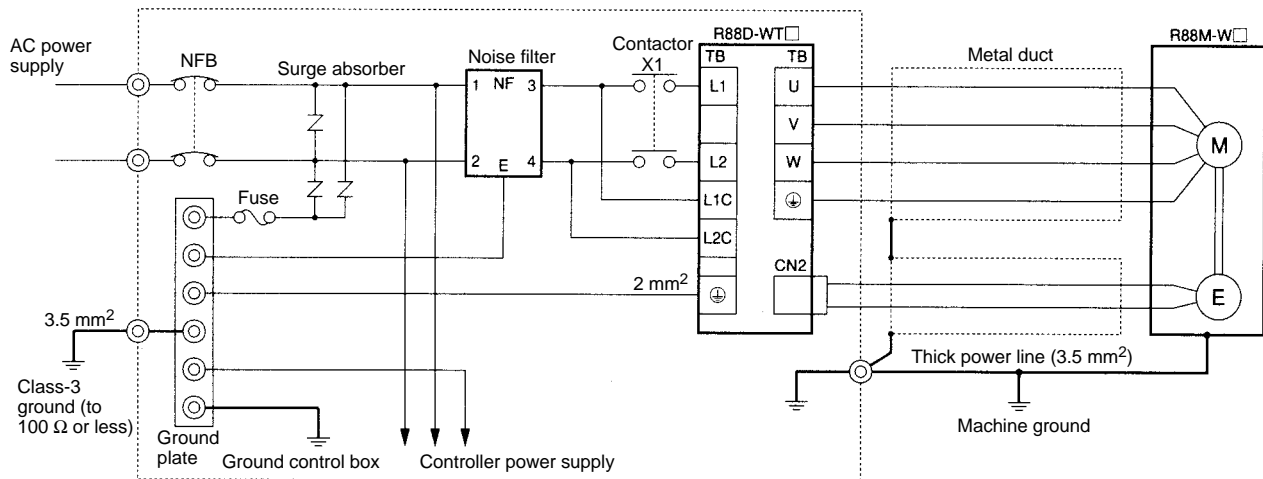

● R88D-WT05H to R88D-WT150H Servo Drivers (Three-phase Power Supply Input)

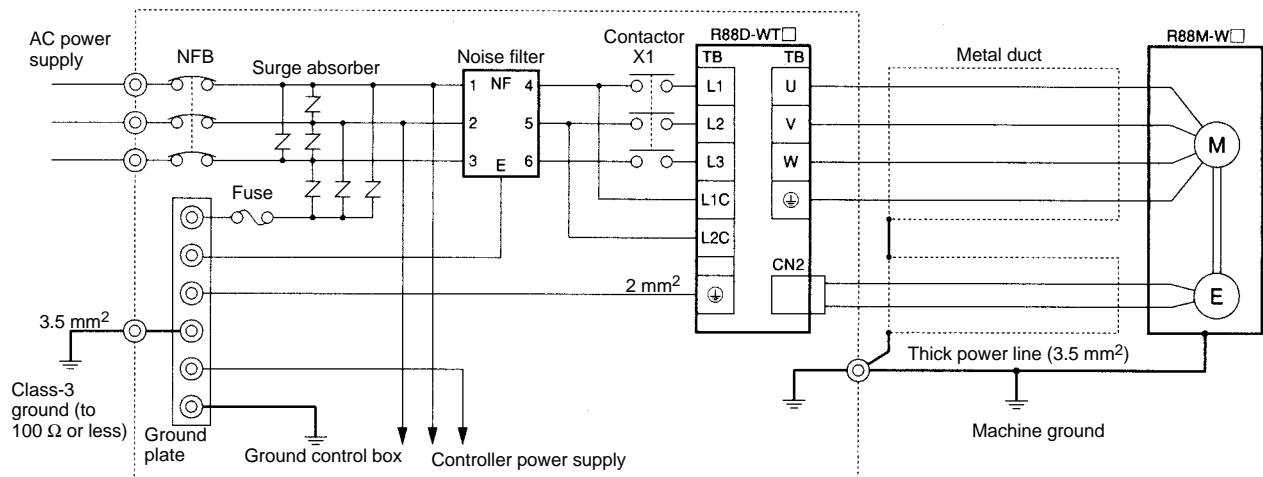

- Ground the motor's frame to the machine ground when the motor is on a movable shaft.
- Use a grounding plate for the frame ground for each Unit, as shown in the above diagrams, and ground to a single point.

- Use ground lines with a minimum thickness of 3.5 mm², and arrange the wiring so that the ground lines are as short as possible.
- If no-fuse breakers are installed at the top and the power supply line is wired from the lower duct, use metal tubes for wiring and make sure that there is adequate distance between the input lines and the internal wiring. If input and output lines are wired together, noise resistance will decrease.
- No-fuse breakers, surge absorbers, and noise filters (NF) should be positioned near the input terminal block (ground plate), and I/O lines should be isolated and wired using the shortest distance possible.
- If surge absorbers are installed, incorporate a fuse to protect against short-circuit failure. As a guide, select a fuse with approximately three times the maximum momentary current.
- Wire the noise filter as shown at the left in the following illustration. The noise filter should be installed at the entrance to the control box whenever possible.

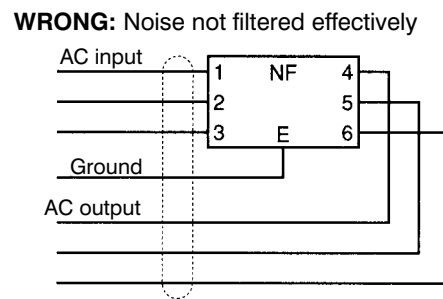
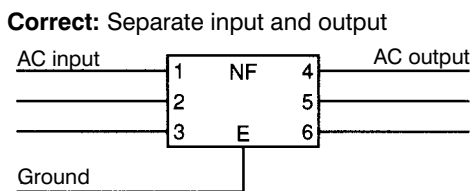

- Use twisted-pair cables for the power supply cables whenever possible, or bind the cables.

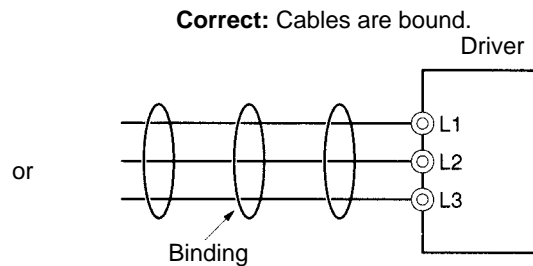
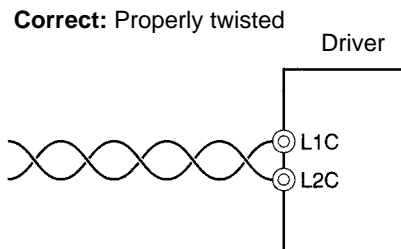

- Separate power supply cables and signal cables when wiring.

■ Selecting Components

This section explains the criteria for selecting the connection components required for improving noise resistance. These criteria include capacity performance, applicable range, and so on. For more details, contact the manufacturers directly.

● **No-fuse Breakers (NFB)**

When selecting no-fuse breakers, take into consideration the maximum output current and the inrush current.

Maximum input current:

The momentary maximum output for a Servo Driver is approximately three times that of the rated output, and a maximum output of three seconds can be executed. Therefore, select no-fuse breakers with an operating time of at least five seconds at 300% of the rated maximum output. General-purpose and low-speed no-fuse breakers are generally suitable. The table in 3-2-3 *Terminal Block Wiring* shows the rated power supply input currents for each Servomotor. Select a no-fuse-breaker with a rated current greater than the total effective load current (when multiple Servomotors are used). When making the selection, add in the current consumption of other controllers, and so on.

Servo Driver inrush current:

With low-speed no-fuse breakers, an inrush current 10 times the rated current flows for 0.02 second. For a simultaneous inrush for multiple Servo Drivers, select a no-fuse-breaker with a 20-ms allowable current greater than the total inrush current shown in the following table for the applicable Servomotor models.

W	Power supply voltage	Model	Capacity	Rated current A (rms)	Inrush current (main power supply circuit) A (0-p)	From rated current (*125%)	No-fuse breaker model
Single-phase	100	WTA3HL	30 W	1.1	90	1.375	NF30-SW 10A
	100	WTA5HL	50 W	1.8	90	2.25	NF30-SW 10A
	100	WT01HL	100 W	3	90	3.75	NF30-SW 10A
	100	WT02HL	200 W	5.2	90	6.5	NF30-SW 10A
Single-phase	200	WTA3H	30 W	0.8	90	1	NF30-SW 10A
	200	WTA5H	50 W	1.1	90	1.375	NF30-SW 10A
	200	WT01H	100 W	2	90	2.5	NF30-SW 10A
	200	WT02H	200 W	3.4	90	4.25	NF30-SW 10A
	200	WT04H	400 W	5.5	90	6.875	NF30-SW 10A
Three-phase	200	WT05H	450 W	4	130	5	NF30-SW 15A
	200	WT08H	750 W	5.4	130	6.75	NF30-SW 15A
	200	WT10H	1 kW	7	130	8.75	NF30-SW 15A
	200	WT15H	1.5 kW	9.5	130	11.875	NF30-SW 15A
	200	WT20H	2 kW	12	140	15	NF30-SW 20A
	200	WT30H	3 kW	17	140	21.25	NF30-SW 30A
	200	WT50H	5 kW	28	140	35	NF50-SW 50A
	200	WT60H	6 kW	32	140	40	NF50-SW 50A
	200	WT75H	7.5 kW	41	140	51.25	NF100-SW 75A
200	WT15K0H	15 kW	81	140	101.25	NF100-SW 125A	

● **Surge Absorbers**

Use surge absorbers to absorb surges from power supply input lines due to lightning, abnormal voltages, etc. When selecting surge absorbers, take into account the varistor voltage, the amount of surge immunity, and the amount of energy resistance. The surge absorbers shown in the following table are recommended.

Maker	Model	Varistor voltage	Max. limit voltage	Surge immunity	Energy resistance	Type
Matsushita Electric	ERZC20EK471(W)	470 V	775 V	5,000 A	150 J	Block
	ERZC25EK471(W)	470 V	775 V	10,000 A	225 J	
	ERZC32EK471(W)	470 V	775 V	20,000 A	405 J	
Ishizuka Electronics Co.	Z25M471S	470 V	775 V	10,000A	235 J	Block
	Z33M471S	470 V	775 V	20,000 A	385 J	

- Note 1.** The (W) for the Matsushita models indicates that they are UL and CSA certified.
- Note 2.** Refer to the manufacturers' documentation for operating details.
- Note 3.** The surge immunity is for a standard impulse current of 8/20 μs. If pulses are wide, either decrease the current or change to a larger-capacity surge absorber.
- Note 4.** The energy resistance is the value for 2 ms. It may not be possible to retard high-energy pulses at less than 700 V. In that case, absorb surges with an insulated transformer or reactor.

● Noise Filters for Power Supply Input

Use a noise filter to attenuate extraneous noise and to diminish noise radiation from the Servo Driver. Select a noise filter with an effective load current of at least twice the rated current. The effective load current is the total of the rated currents for the main circuit power supply input and the control circuit power supply input given in *3-2-3 Terminal Block Wiring*. The following table shows noise filters that reduce by 40 dB noise between 200 kHz and 30 MHz.

Type	Model	Rated current	Maker
Single-phase	GT-2050	5 A	NEC TOKIN
	LF-210N	10 A	
	LF-215N	15 A	
	LF-220N	20 A	
Three-phase	LF-315K	15 A	NEC TOKIN
	LF-325K	25 A	
	LF-335K	35 A	
	LF-380K	80 A	
	ZCW2210-01	10 A	TDK
	ZCW2220-01	20 A	
	ZCW2230-01	30 A	
	ZCW2240-01	40 A	
	ZACT2280-ME	80 A	

- Note 1.** To attenuate noise at frequencies of 200 kHz or less, use an insulated transformer and a noise filter. For high frequencies of 30 MHz or more, use a ferrite core and a high-frequency noise filter with a through-type capacitor.
- Note 2.** If multiple Servo Drivers are to be connected to a single noise filter, select a noise filter with a rated current at least two times the total rated current of all the Servo Drivers.

● Noise Filters for Servomotor Output

Use noise filters without built-in capacitors on the Servomotor output lines. Select a noise filter with a rated current at least two times the total rated current of the Servo Driver's continuous output current. The following table shows the noise filters that are recommended for Servomotor output.

Maker	Model	Rated current	Remarks
NEC TOKIN	LF-310KA	10 A	Three-phase block noise filter
	LF-320KA	20 A	
	LF-350KA	50 A	
	LF-3110KA	110 A	

Note 1. Servomotor output lines cannot use the same noise filters used for power supplies.

Note 2. Typical noise filters are used with power supply frequencies of 50/60 Hz. If these noise filters are connected to outputs of 11.7 kHz/5.9 kHz (the Servo Driver's PWM frequency), a very large (about 100 times larger) leakage current will flow through the noise filter's condenser and the Servo Driver could be damaged.

● **Surge Killers**

Install surge killers for loads that have induction coils, such as relays, solenoids, brakes, clutches, etc. The following table shows types of surge killers and recommended products.

Type	Features	Recommended products
Diode	Diodes are used for relatively small loads when the reset time is not an issue, such as relays. The reset time is increased because the surge voltage is the lowest when power is cut off. Used for 24/48-V DC systems.	Use a fast-recovery diode with a short reverse recovery time. Example: Fuji Electric Co., ERA22-06
Thyristor or varistor	Thyristors and varistors are used for loads when induction coils are large, as in electro-magnetic brakes, solenoids, etc., and when reset time is an issue. The surge voltage when power is cut off is approximately 1.5 times the varistor voltage.	Select the varistor voltage as follows: 24 V DC system: 39 V 100 V DC system: 200 V 100 V AC system: 270 V 200 V AC system: 470 V
Capacitor + resistor	The capacitor + resistor combination is used to absorb vibration in the surge when power is cut off. The reset time can be shortened by selecting the appropriate capacitance and resistance.	Okaya Electric Industries Co., Ltd. XEB12002 0.2 μF – 120 Ω XEB12003 0.3 μF – 120 Ω

Note Thyristors and varistors are made by the following companies. Refer to manufacturers documentation for operating details. Thyristors: Ishizuka Electronics Co.

Varistors: Ishizuka Electronics Co., Matsushita Electric Industrial Co.

● **Contactors**

When selecting contactors, take into consideration the circuit's inrush current and the maximum momentary current. The Servo Driver inrush current is covered in the preceding explanation of no-fuse-breaker selection, and the maximum momentary current is approximately twice the rated current. The following table shows the recommended contactors.

Maker	Model	Rated current		Coil voltage
OMRON	J7L-09	11 A		200 V AC
	J7L-32	26 A		
	J7L-40	35 A		
	J7L-50	50 A		
	J7L-85	80 A		
	J7L-12	Two poles	12 A	24 V DC
		Three poles	12 A	
	J7L-32	Two poles	25 A	
		Three poles	25 A	
	J7L-40	Two poles	35 A	
		Three poles	35 A	
	J7L-50	Two poles	45 A	
		Three poles	50 A	
	J7L-85	Two poles	65 A	
Three poles		80 A		

• Leakage Breakers

Select leakage breakers designed for inverters.

Since switching takes place inside the Servo Drivers, harmonic current leaks from the armature of the motor. With inverter leakage breakers, harmonic current is not detected, preventing the breaker from operating due to leakage current.

When selecting leakage breakers, remember to also add the leakage current from devices other than the Servomotor, such as machines using a switching power supply, noise filters, inverters, and so on. For details on leakage breakers, refer to the manufacturer’s catalog.

The following table shows the Servomotor leakage current for each Servo Driver model.

Driver	Leakage current (resistor/capacitor measurement) (commercial power supply frequency range)
R88D-WTA3HL to -WT02HL	16 mA
R88D-WTA3H to -WT04H	8 mA
R88D-WT05H to -WT10H	3 mA
R88D-WT15H	5 mA
R88D-WT20H/-WT30H	6 mA
R88D-WT50H	9 mA
R88D-WT60H/-WT75H	21 mA
R88D-WT150H	57 mA

Note 1. The above leakage current is for cases where Servomotor power line length is less than 10 meters. (It varies depending on the power line length and the insulation.)

Note 2. The above leakage current is for normal temperature and humidity. (It varies depending on the temperature and humidity.)

Leakage Breaker Connection Example

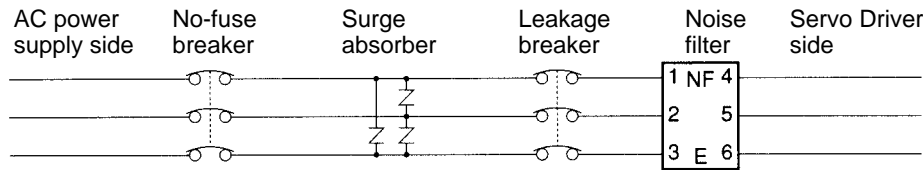

• Harmonic Current Countermeasures (AC Reactor)

The AC Reactor is used for suppressing harmonic currents. It suppresses sudden and quick changes in electric currents.

In September 1994, the Ministry of International Trade and Industry established guidelines for the suppression of harmonic waves emitted from home and general electric appliances. To comply with the guidelines, appropriate measures are required to suppress the influence of harmonic waves on power supply lines.

Select the proper AC Reactor model according to the Servo Driver that is to be used.

Note DC Reactors cannot be connected to models R88D-WT60H to R88D-WT150H, so use an AC Reactor instead.

Servo Drive	Reactor specifications			
	Model number	Rated current (A)	Inductance (mH)	Reactor type
R88D-WTA3HL/A5HL/01HL	R88A-PX5063	1.8	10.0	DC Reactor
R88D-WT02HL	R88A-PX5062	3.5	4.7	
R88D-WTA3H/A5H/01H	R88A-PX5071	0.85	40.0	
R88D-WT02H	R88A-PX5070	1.65	20.0	
R88D-WT04H	R88A-PX5069	3.3	10.0	
R88D-WT05H/08H/10H	R88A-PX5061	4.8	2.0	
R88D-WT15H/20H	R88A-PX5060	8.8	1.5	
R88D-WT30H	R88A-PX5059	14.0	1.0	
R88D-WT50H	R88A-PX5068	26.8	0.47	
R88D-WT60H	3G3IV-PUZBAB40A0.265MH	40	0.265	AC Reactor
R88D-WT75H	3G3IV-PUZBAB60A0.18MH	60	0.18	
R88D-WT150H	3G3IV-PUZBAB90A0.12MH	90	0.12	

DC Reactor Connection Example

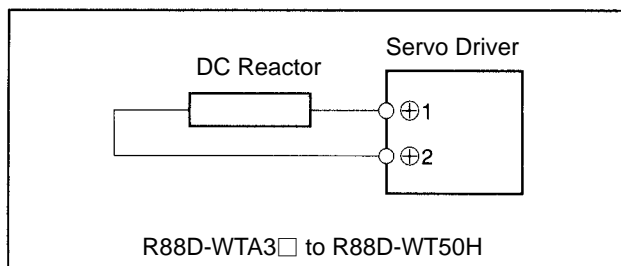

AC Reactor Connection Example

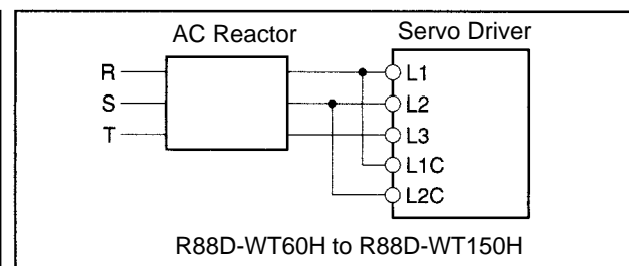

■ Improving Encoder Cable Noise Resistance

The OMNUC W Series uses serial encoders, with phase-S signals from the encoder. The phase-S communications speed is 4 Mbits/s.

In order to improve the encoder’s noise resistance, take the following measures for wiring and installation.

- Always use the specified Encoder Cables.
- If lines are interrupted in the middle, be sure to connect them with connectors, making sure that the cable insulation is not peeled off for more than 50 mm. In addition, always use shielded cable.
- Do not coil cables. If cables are long and are coiled, mutual induction and inductance will increase and will cause malfunctions. Always use cables fully extended.
- When installing noise filters for Encoder Cables, use clamp filters. The following table shows the recommended clamp filter models.

Maker	Name	Model
NEC TOKIN	EMI core	ESD-SR-25
TDK	Clamp filter	ZCAT2032-0930
		ZCAT3035-1330
		ZCAT2035-0930A

- Do not place the Encoder Cable in the same duct as Power Cables and Control Cables for brakes, solenoids, clutches, and valves.

■ Improving Control I/O Signal Noise Resistance

Positioning can be affected if control I/O signals are influenced by noise.

- Use completely separate power supplies for the control power supply (especially 24 V DC) and the external operation power supply. In particular, be careful not to connect the two power supply ground wires. Install a noise filter on the primary side of the control power supply.
- As much as possible, keep the power supply for pulse command and deviation counter reset input lines separate from the control power supply. Be particularly careful not to connect the two power supply ground lines.
- It is recommended that a line driver be used for pulse command and deviation counter reset outputs.
- Always use twisted-pair shielded cable for pulse command and deviation counter reset signal lines, and connect both ends of the shield to frame grounds.
- Always use twisted-pair shielded cable for speed and torque command signal lines, and connect both ends of the shield to frame grounds.
- If the control power supply wiring is long, noise resistance can be improved by adding 1-μF laminated ceramic capacitors between the control power supply and ground at the Servo Driver input section or the controller output section.
- For encoder output (phase-A, -B, and -Z) lines, be sure to use twisted-pair shielded cable, and connect both ends of the shield to frame grounds.
- For open-collector specifications, keep the length of wires to within two meters.

3-2-5 Wiring for Conformity to EMC Directives

When the wiring conditions provided in this section are satisfied, the wiring will conform to EMC Directives (EN55011 Class A Group 1 (EMI), EN61000-6-2 (EMS)). These

conditions were stipulated when EMC Directive approval was obtained for the W Series. They will be affected by the installation and wiring conditions resulting from the connected devices and wiring when the W Series is built into the system. Therefore, the entire system must be checked for conformity.

The following conditions must be satisfied in order to conform to the EC Directives.

- The Servo Driver must be mounted in a metal case (control box). (It is not necessary to mount the Servomotor in a metal box.)
- Noise filters and surge absorbers must be inserted in power supply lines.
- Shielded cable must be used for I/O signal cables and encoder cables. (Use tinned soft steel wire.)
- Cables leading out from the control box must be enclosed within metal ducts or conduits with blades. (It is not necessary to enclose the 30-cm power cable, encoder cable, or connectors in a metal duct or conduit.)
- Ferrite cores must be installed for cables with braided shields, and the shield must be directly grounded to a ground plate.

■ Wiring Method

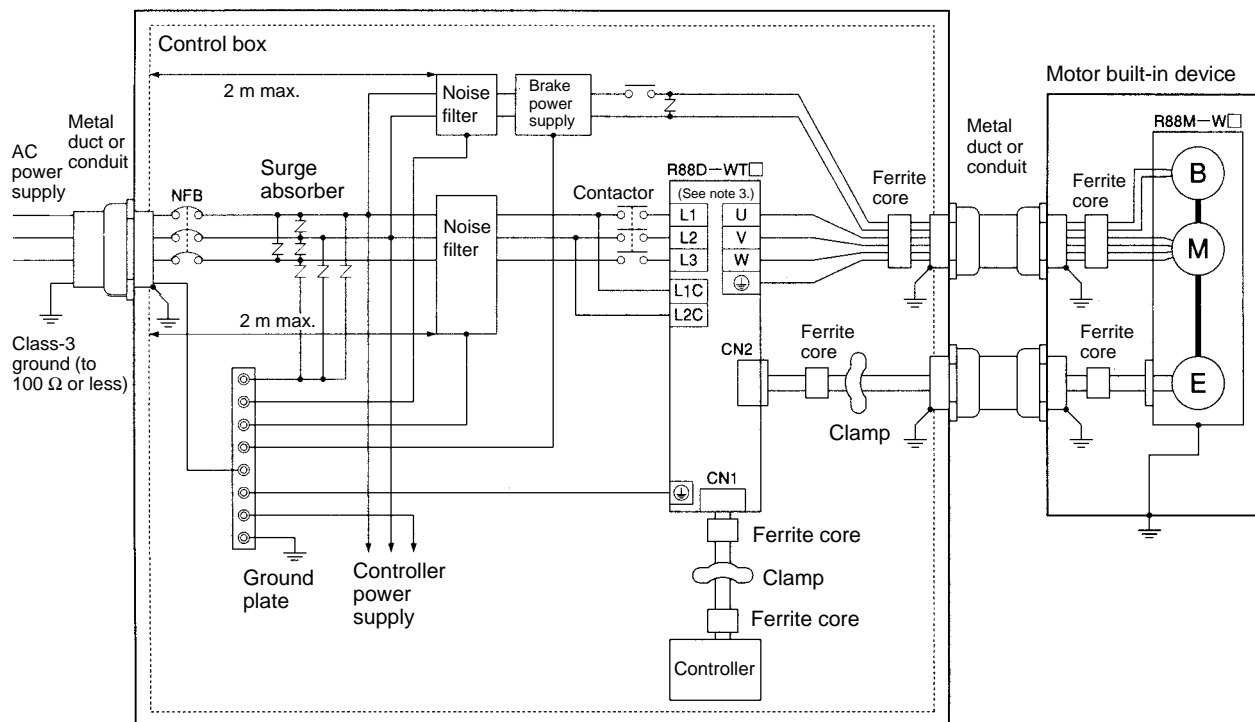

Note 1. Make 1.5 turns for the ferrite core's cable winding.

Note 2. Peel the insulation off the cable at the clamp, and directly connect the shield to the metal plate.

Note 3. For single-phase power supply input models (R88D-WTA3H□ to R88D-WT04H), the main-circuit power supply input terminals will be L1 and L2.

- Ground the motor's frame to the machine ground when the motor is on a movable shaft.
- Use a grounding plate for the frame ground for each Unit, as shown in the above diagrams, and ground to a single point.

- Use ground lines with a minimum thickness of 3.5 mm², and arrange the wiring so that the ground lines are as short as possible.
- If no-fuse breakers are installed at the top and the power supply line is wired from the lower duct, use metal tubes for wiring and make sure that there is adequate distance between the input lines and the internal wiring. If input and output lines are wired together, noise resistance will decrease.
- No-fuse breakers, surge absorbers, and noise filters should be positioned near the input terminal block (ground plate), and I/O lines should be isolated and wired using the shortest distance possible.
- Wire the noise filter as shown at the left in the following illustration. The noise filter should be installed at the entrance to the control box whenever possible.

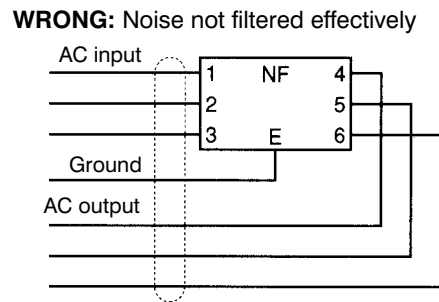
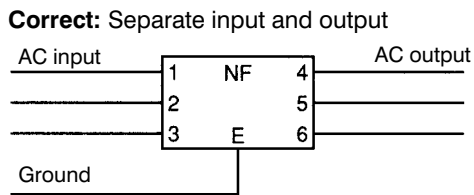

- Use twisted-pair cables for the power supply cables whenever possible, or bind the cables.

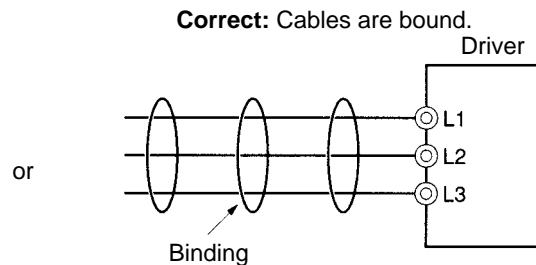
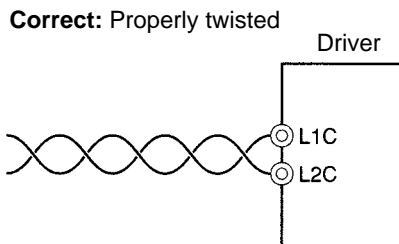

- Separate power supply cables and signal cables when wiring.

■ Control Box Structure

If there are gaps in the control box from cable openings, operating panel installation holes, gaps around the door, and so on, it may allow electric waves to penetrate. In order to prevent this from occurring, take the measures described below.

● Case Structure

- Construct the control box case of metal, and weld the joints between the top, bottom, and sides so that they will be electrically conductive.
- For assembly, strip the paint off of joined areas (or mask them during painting), to make them electrically conductive.
- If gaps are opened in the control box case when tightening down screws, make adjustments to prevent this from occurring.
- Do not leave any conducting part unconnected.

- Connect to the case all Units inside of the case.
- **Door Structure**
 - Construct the door of metal.
 - Use a water draining structure where the door and case fit together, and leave no gaps. (Refer to the diagrams below.)
 - Use conductive packing between the door and the case, as shown in the diagrams below. Strip the paint off of the sections of the door and case that will be in contact with the conductive packing (or mask them during painting), so that they will be electrically conductive.
 - Be careful not to let gaps be opened in the control box while tightening down screws.

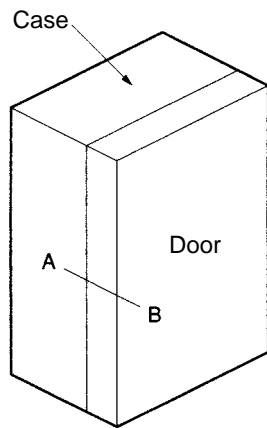

Control box

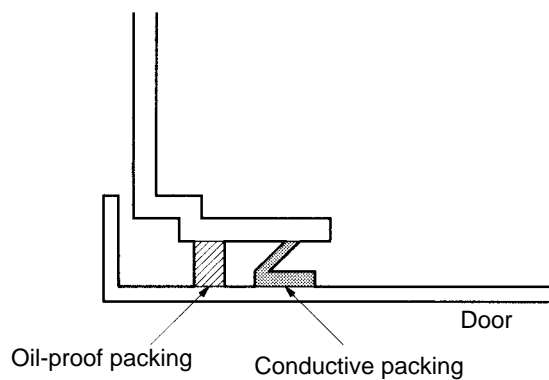

Cross-sectional view of A-B

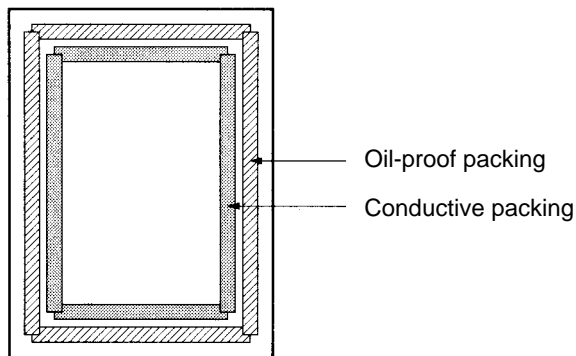

Door (interior view)

■ Selecting Components

This section explains the criteria for selecting the connection components required for improving noise resistance. These criteria include capacity performance, applicable range, and so on. For more details, contact the manufacturers directly.

● **No-fuse Breakers (NFB)**

When selecting no-fuse breakers, take into consideration the maximum output current and the inrush current.

Maximum input current:

The momentary maximum output for a Servo Driver is approximately three times that of the rated output, and a maximum output of three seconds can be executed. Therefore, select no-fuse breakers with an operating time of at least five seconds at 300% of the rated maximum output. General-purpose and low-speed no-fuse breakers are generally suitable. The table in 3-2-3 *Terminal Block Wiring* shows the rated power supply input currents for each Servomotor. Select a no-fuse-breaker with a rated current greater than the total effective load current (when multiple Servomotors are used). When making the selection, add in the current consumption of other controllers, and so on.

Servo Driver inrush current:

With low-speed no-fuse breakers, an inrush current 10 times the rated current flows for 0.02 second. For a simultaneous inrush for multiple Servo Drivers, select a no-fuse-breaker with a 20-ms allowable current greater than the total inrush current shown in the following table for the applicable Servomotor models.

Servo Driver	Inrush current (Ao-p)	
	Control-circuit power supply	Main-circuit power supply
R88D-WTA3HL to -WT02HL	30	90
R88D-WTA3H to -WT04H	35	90
R88D-WT05H to -WT10H	60	130
R88D-WT15H	60	130
R88D-WT20H/-WT30H	60	140
R88D-WT50H	60	140
R88D-WT60H	65	140
R88D-WT75H	65	140
R88D-WT150H	65	140

● **Surge Absorbers**

Use surge absorbers to absorb surges from power supply input lines due to lightning, abnormal voltages, etc. When selecting surge absorbers, take into account the varistor voltage, the amount of surge immunity, and the amount of energy resistance. The surge absorbers shown in the following table are recommended.

Maker	Model	Max. limit voltage	Surge immunity	Type	Remarks
Okaya Electric Industries Co., Ltd.	R•A•V-781BYZ-2	783 V	1,000 A	Block	Between power supply lines
	R•A•V-781BXZ-4	783 V	1,000 A		Between power supply line grounds

Note 1. Refer to the manufacturers' documentation for operating details.

Note 2. The surge immunity is for a standard impulse current of 8/20 μs. If pulses are wide, either decrease the current or change to a larger-capacity surge absorber.

● **Noise Filters for Power Supply Input**

Use the following noise filters for the Servo Driver power supply

Servo Driver model	Noise Filter				
	Model	Rated current	Rated voltage	Leakage current (See note.)	Maker
R88D-WTA3HL to WT01HL	SUP-P5H-EPR	5 A	250 V	0.6 mA (at 250 Vrms, 60 Hz)	Okaya Electric Industries Co., Ltd.
R88D-WT02HL	SUP-P8H-EPR	8 A			
R88D-WTA3H to WT02H	SUP-P5H-EPR	5 A	250 V	0.6 mA (at 250 Vrms, 60 Hz)	Okaya Electric Industries Co., Ltd.
R88D-WT04H	SUP-P8H-EPR	8 A			
R88D-WT05H	FN351-8/29	8 A	440 V	1.9 mA (at 400 Vrms, 50 Hz)	Schaffner
R88D-WT08H to WT15H	FN351-16/29	16 A		1.9 mA (at 400 Vrms, 50 Hz)	
R88D-WT20H	FN351-25/33	25 A		28 mA (at 400 Vrms, 50 Hz)	
R88D-WT30H	FN351-36/33	36 A		28 mA (at 400 Vrms, 50 Hz)	
R88D-WT50H to WT60H	FMAC-0934-5010	50 A	480 V	5 mA (at 440 Vrms, 50 Hz)	TIMONTA
R88D-WT75H	FMAC-0953-6410	64 A		5 mA (at 440 Vrms, 50 Hz)	
R88D-WT150H	FS5559-150-35	150 A		1.8 mA (at 480 Vrms, 50 Hz)	Schaffner

Note The leakage currents shown for Schaffner noise filters are the values for when a three-phase power supply uses a Y connection. The leakage current will be greater for a Δ connection.

External Dimensions

● **SUP-P□H-EPR Noise Filters (by Okaya Electric Industries Co., Ltd.)**

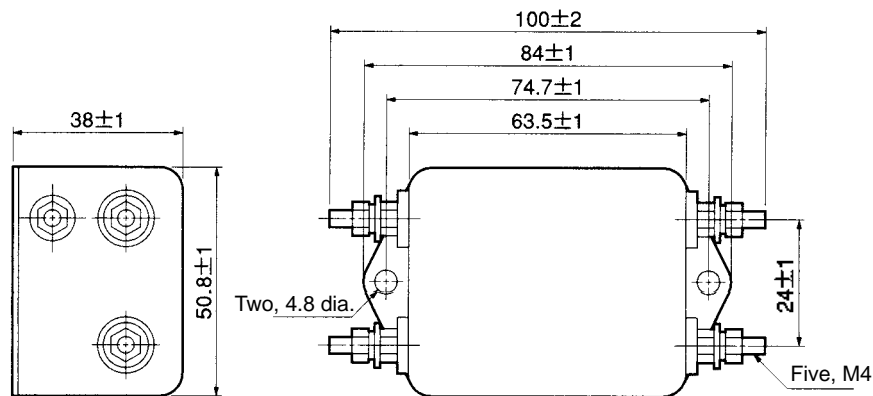

• FN351-□ Noise Filters (by Schaffner)

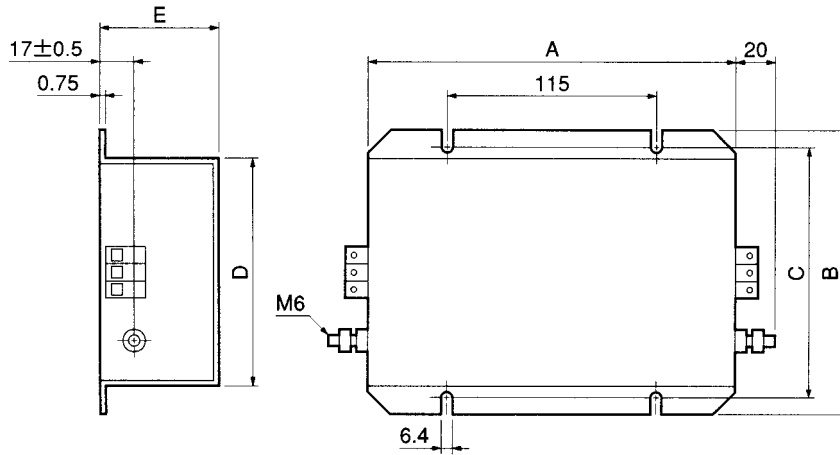

Model	Dimensions (mm)				
	A	B	C	D	E
FN351-8/29	180	115	100	85	60
FN351-16/29	200	150	136	120	65
FN351-25/33					
FN351-36/33					

• FMAC-□ Noise Filters (by Timonta)

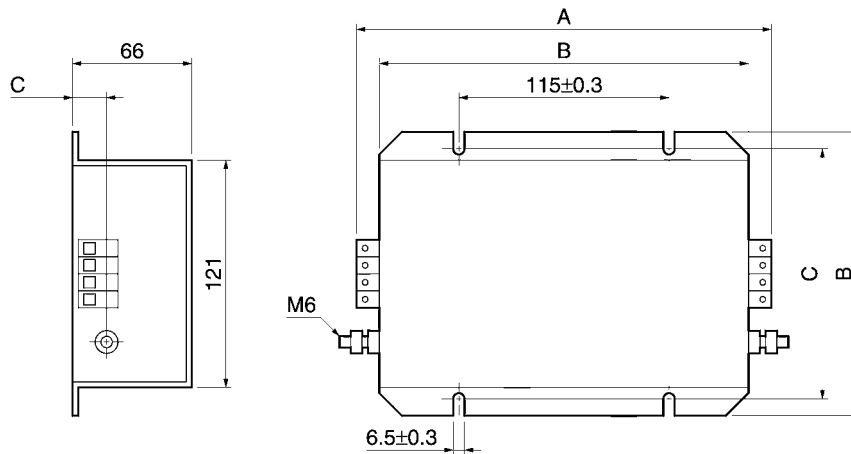

Model	Dimensions (mm)		
	A	B	C
FMAC-0934-5010	250	201	17
FMAC-0953-6410	308	231	34

• FS5559-150-35 Noise Filters (by Schaffner)

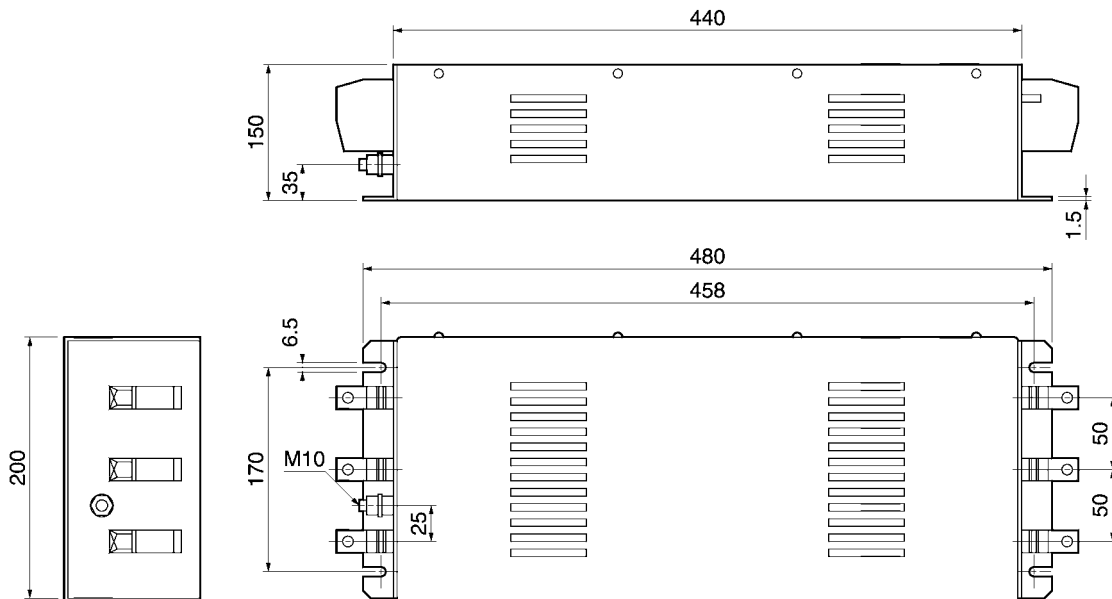

• **Noise Filter for Brake Power Supply**

Use the following noise filter for the brake power supply. (Refer to the SUP-P□H-EPR diagram above for dimensions.)

Model	Rated current	Rated voltage	Leakage current	Maker
SUP-P5H-EPR	5 A	250 V	0.6 mA (at 250 Vrms, 60 Hz)	Okaya Electric Industries Co., Ltd.

• **Surge Killers**

Install surge killers for loads that have induction coils, such as relays, solenoids, brakes, clutches, etc. The following table shows types of surge killers and recommended products.

Type	Features	Recommended products
Diode	Diodes are relatively small devices such as relays used for loads when reset time is not an issue. The reset time is increased because the surge voltage is the lowest when power is cut off. Used for 24/48-V DC systems.	Use a fast-recovery diode with a short reverse recovery time. Fuji Electric Co., ERB44-06 or equivalent
Thyristor or Varistor	Thyristor and varistor are used for loads when induction coils are large, as in electromagnetic brakes, solenoids, etc., and when reset time is an issue. The surge voltage when power is cut off is approximately 1.5 times that of the varistor.	Select varistor voltage as follows: 24-V DC system: 39 V 100-V DC system: 200 V 100-V AC system: 270 V 200-V AC system: 470 V
Capacitor + resistor	Use capacitors and resistors for vibration absorption of surge when power is cut off. The reset time can be shortened by proper selection of the capacitor or resistor.	Okaya Electric Industries Co., Ltd. CR-50500 0.5 μF-50 Ω CRE-50500 0.5 μF-50 Ω S2-A-0 0.2 μF-500 Ω

Note Thyristors and varistors are made by the following companies. Refer to manufacturers' documentation for operating details. Thyristors: Ishizuka Electronics Co.
Varistors: Ishizuka Electronics Co., Matsushita Electric Industrial Co.

• **Contactors**

When selecting contactors, take into consideration the circuit's inrush current and the maximum momentary current. The Servo Driver inrush current is covered in the preceding explanation of no-fuse-breaker selection, and the maximum momentary current is approximately twice the rated current. The following table shows the recommended contactors.

Maker	Model	Rated current	Coil voltage
OMRON	LC1D09106	11 A	200 V AC
	LC1D25106	26 A	
	LC1D40116	35 A	
	LC1D50116	50 A	
	LC1D80116	80 A	
	LC1D09106	11 A	
LP1D25106	26 A		
LP1D40116	35 A		
LP1D50116	50 A		
LP1D80116	80 A		

Leakage Current and Leakage Breakers

Use a surge-resistant leakage breaker designed for Inverters that will not operate for high-frequency currents. The detection current of a leakage breaker is set to approximately 60% of the normal rated current. You should thus allow a leeway of approximately two times the rated current.

Leakage current will also flow to the input noise filter, switch mode power supply, and other devices. Be sure to allow for these devices as well.

Values indicated with asterisks are measured using the UL (JIS) methods.

Servo Driver model	*Leakage current (for 10-m cable)	*Additional leakage current per 10 m of cable	PWM frequency	Input power supply voltage
R88D-WTA3HL	2.5 mA	0.5 mA	11.7 kHz	Single-phase 100/115 VAC (85 to 127 V), 50/60 Hz
R88D-WTA5HL				
R88D-WT01HL				
R88D-WT02HL	3.0 mA			
R88D-WTA3H	5.0 mA			
R88D-WTA5H				
R88D-WT01H				
R88D-WT02H	8.0 mA			
R88D-WT04H				
R88D-WT05H				
R88D-WT08H				
R88D-WT10H	10.0 mA	0.6 mA	3.9 kHz	Single-phase 200/230 VAC (170 to 253 V), 50/60 Hz
R88D-WT15H				
R88D-WT20H	12.0 mA	0.7 mA		
R88D-WT30H				
R88D-WT50H	15.0 mA	0.8 mA		
R88D-WT60H	21.0 mA	1.0 mA		
R88D-WT75H				
R88D-WT150H	57.0 mA	1.5 mA		

Leakage Breaker Connection Example

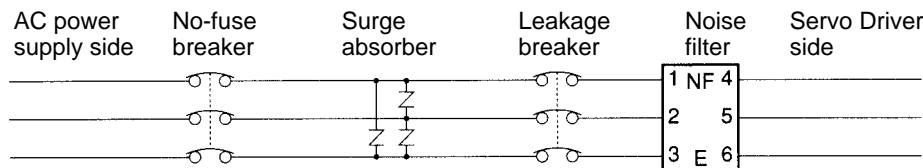

Improving Encoder Cable Noise Resistance

The OMNUC W Series uses serial encoders, with phase-S signals from the encoder. The phase-S communications speed is 4 Mbits/s.

In order to improve the encoder’s noise resistance, take the following measures for wiring and installation.

- Always use the specified Encoder Cables.
- If lines are interrupted in the middle, be sure to connect them with connectors, making sure that the cable insulation is not peeled off for more than 50 mm. In addition, always use shielded cable.

- Do not coil cables. If cables are long and are coiled, mutual induction and inductance will increase and will cause malfunctions. Always use cables fully extended.
- When installing noise filters for Encoder Cables, use clamp filters. The following table shows the recommended clamp filter models.

Maker	Name	Model
NEC TOKIN	EMI core	ESD-SR-25
TDK	Clamp filter	ZCAT2032-0930
		ZCAT3035-1330
		ZCAT2035-0930A

- Do not place the Encoder Cable in the same duct as Power Cables and Control Cables for brakes, solenoids, clutches, and valves.

■ Improving Control I/O Signal Noise Resistance

Positioning can be affected if control I/O signals are influenced by noise. Follow the methods outlined below for the power supply and wiring.

- Use completely separate power supplies for the control power supply (especially 24 V DC) and the external operation power supply. In particular, be careful not to connect the two power supply ground wires. Install a noise filter on the primary side of the control power supply.
- As much as possible, keep the power supply for pulse command and deviation counter reset input lines separate from the control power supply. Be particularly careful not to connect the two power supply ground lines.
- It is recommended that a line driver be used for pulse command and deviation counter reset outputs.
- Always use twisted-pair shielded cables for pulse command and deviation counter reset signal lines, and connect both ends of the shield to frame grounds.
- Always use twisted-pair shielded cable for speed and torque command signal lines, and connect both ends of the shield to frame grounds.
- If the control power supply wiring is long, noise resistance can be improved by adding 1- μ F laminated ceramic capacitors between the control power supply and ground at the Servo Driver input section or the controller output section.
- For encoder output (phase-A, -B, and -Z) lines, be sure to use twisted-pair shielded cable, and connect both ends of the shield to frame grounds.
- For open-collector specifications, keep the length of wires to within two meters.

3-3 Regenerative Energy Absorption

The Servo Drivers have internal regenerative energy absorption circuitry for absorbing the regenerative energy produced during time such as Servomotor deceleration, and thus preventing the DC voltage from increasing. An overcurrent error is generated, however, if the amount of regenerative energy from the Servomotor is too large. If this occurs, measures must be taken to reduce the regenerative energy produced by changing operating patterns, and so on, or to improve the regenerative energy absorption capacity by connecting external regeneration resistance.

3-3-1 Regenerative Energy Calculation

■ Horizontal Axis

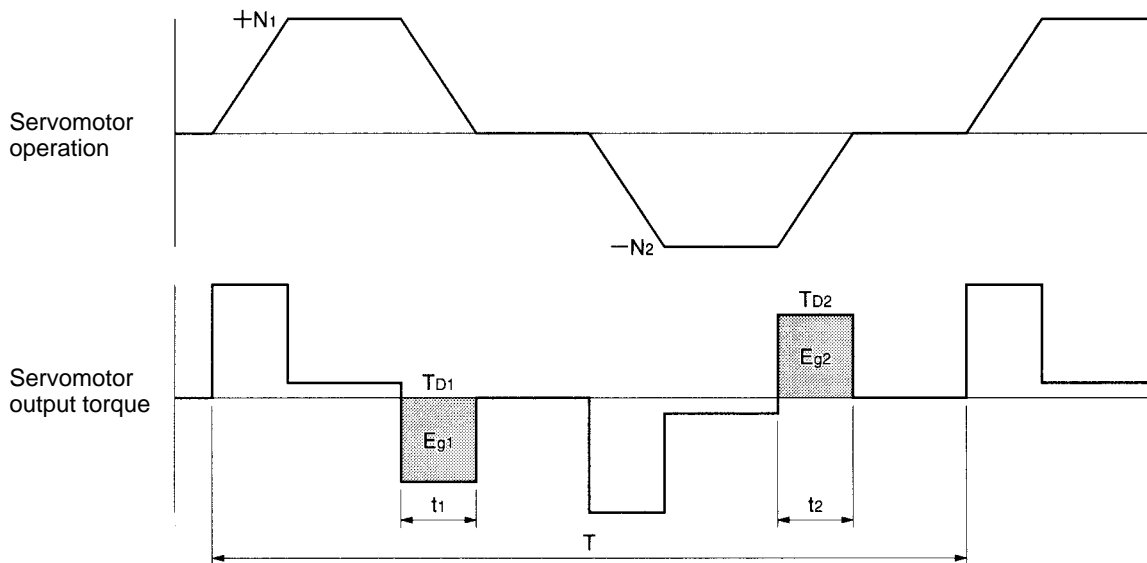

Note In the output torque graph, acceleration in the positive direction is shown as positive, and acceleration in the negative direction is shown as negative.

- The regenerative energy values for E_{g1} and E_{g2} are derived from the following equations.

$$E_{g1} = \frac{1}{2} \cdot \frac{2\pi}{60} \cdot N_1 \cdot T_{D1} \cdot t_1 \quad [\text{J}]$$

$$E_{g2} = \frac{1}{2} \cdot \frac{2\pi}{60} \cdot N_2 \cdot T_{D2} \cdot t_2 \quad [\text{J}]$$

N_1, N_2 : Rotation speed at beginning of deceleration [r/min]

T_{D1}, T_{D2} : Deceleration torque [N•m]

t_1, t_2 : Deceleration time [s]

Note There is some loss due to winding resistance, so the actual regenerative energy will be approximately 90% of the values derived from these equations.

- For Servo Driver models with internal capacitors for absorbing regenerative energy (i.e., models of 400 W or less.), the values for both E_{g1} or E_{g2} (unit: J) must be lower than the Servo Driver's regen-

erative energy absorption capacity. (The capacity varies depending on the model. For details, refer to 3-3-2 Servo Driver Regenerative Energy Absorption Capacity.)

- For Servo Driver models with internal regeneration resistance for absorbing regenerative energy (i.e., models of 500 W or more), the average amount of regeneration P_r (unit: W) must be calculated, and this value must be lower than the Servo Driver’s regenerative energy absorption capacity. (The capacity varies depending on the model. For details, refer to 3-3-2 Servo Driver Regenerative Energy Absorption Capacity.)

The average amount of regeneration (P_r) is the power consumed by regeneration resistance in one cycle of operation.

$$P_r = (E_{g1} + E_{g2})/T \quad [W]$$

T: Operation cycle [s]

■ **Vertical Axis**

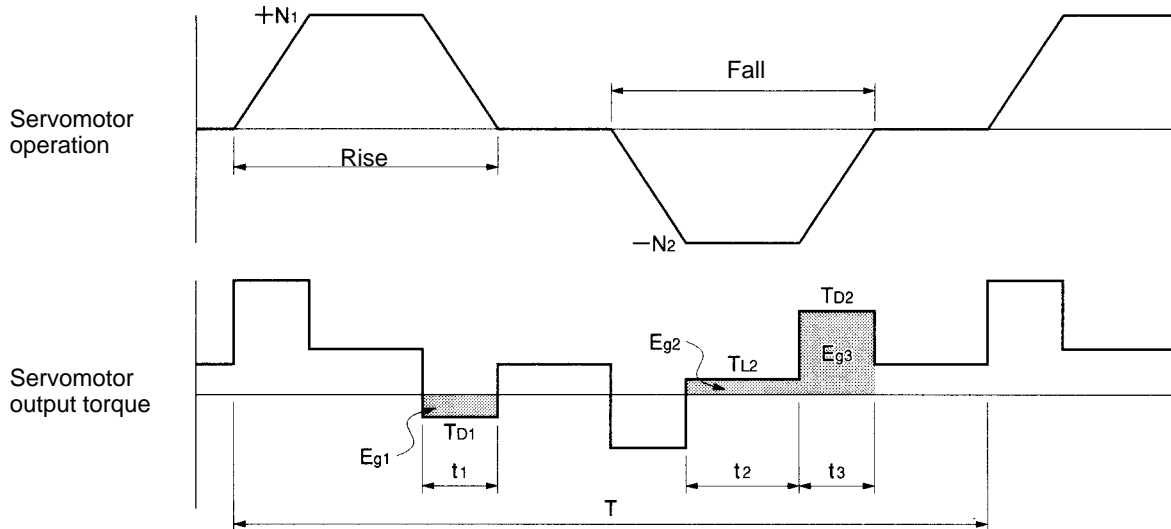

Note In the output torque graph, acceleration in the positive direction (rise) is shown as positive, and acceleration in the negative direction (fall) is shown as negative.

- The regenerative energy values for E_{g1} , E_{g2} , and E_{g3} are derived from the following equations.

$$E_{g1} = \frac{1}{2} \cdot \frac{2\pi}{60} \cdot N_1 \cdot T_{D1} \cdot t_1 \quad [J]$$

$$E_{g2} = \frac{2\pi}{60} \cdot N_2 \cdot T_{L2} \cdot t_2 \quad [J]$$

$$E_{g3} = \frac{1}{2} \cdot \frac{2\pi}{60} \cdot N_2 \cdot T_{D2} \cdot t_3 \quad [J]$$

N_1, N_2 : Rotation speed at beginning of deceleration [r/min]

T_{D1}, T_{D2} : Deceleration torque [N•m]

T_{L2} : Torque when falling [N•m]

t_1, t_3 : Deceleration time [s]

t_2 : Constant-velocity travel time when falling [s]

Note There is some loss due to winding resistance, so the actual regenerative energy will be approximately 90% of the values derived from these equations.

- For Servo Driver models with internal capacitors for absorbing regenerative energy (i.e., models of 400 W or less.), the values for both E_{g1} or $E_{g2} + E_{g3}$ (unit: J) must be lower than the Servo Driver's regenerative energy absorption capacity. (The capacity varies depending on the model. For details, refer to *3-3-2 Servo Driver Regenerative Energy Absorption Capacity*.)
- For Servo Driver models with internal regeneration resistance for absorbing regenerative energy (i.e., models of 500 W or more), the average amount of regeneration P_r (unit: W) must be calculated, and this value must be lower than the Servo Driver's regenerative energy absorption capacity. (The capacity varies depending on the model. For details, refer to *3-3-2 Servo Driver Regenerative Energy Absorption Capacity*.)

The average amount of regeneration (P_r) is the power consumed by regeneration resistance in one cycle of operation.

$$P_r = (E_{g1} + E_{g2} + E_{g3})/T \quad [\text{W}]$$

T: Operation cycle [s]

3-3-2 Servo Driver Regenerative Energy Absorption Capacity

■ Amount of Internal Regeneration Resistance in Servo Drivers

W-series Servo Drivers absorb regenerative energy by means of internal capacitors or resistors. If the regenerative energy is more than can be processed internally, an overvoltage error is generated and operation cannot continue. The following table shows the regenerative energy (and amount of regeneration) that the individual Servo Drivers themselves can absorb. If these values are exceeded, take the following measures.

- Connect external regeneration resistance (to improve the regeneration processing capacity).
- Reduce the operating rotation speed. (The amount of regeneration is proportional to the square of the rotation speed.)
- Lengthen the deceleration time (to decrease the regenerative energy produced per time unit).
- Lengthen the operation cycle, i.e., the cycle time (to decrease the average regenerative power).

Servo Driver	Regenerative energy (J) that can be absorbed by internal capacitor (See note 1.)	Internal regeneration resistance	
		Average amount of regeneration that can be absorbed (W)	Resistance (Ω)
R88D-WTA3HL	7.8	–	–
R88D-WTA5HL	15.7	–	–
R88D-WT01HL	15.7	–	–
R88D-WT02HL	15.7	–	–
R88D-WTA3H	18.5	–	–
R88D-WTA5H	18.5	–	–
R88D-WT01H	37.1	–	–
R88D-WT02H	37.1	–	–
R88D-WT04H	37.1	–	–
R88D-WT05H	–	12	50
R88D-WT08H	–	12	50
R88D-WT10H	–	12	50
R88D-WT15H	–	14	30
R88D-WT20H	–	28	25
R88D-WT30H	–	28	12.5
R88D-WT50H	–	56	8
R88D-WT60H	–	–	–
R88D-WT75H	–	–	–
R88D-WT150H	–	–	–

Note 1. These are the values at 100 V AC for 100-V AC models, and at 200 V AC for 200-V AC models.

Note 2. The R88D-WT60H to R88D-WT150H models do not have built-in regeneration resistor. External resistance must be connected according to the amount of regeneration.

3-3-3 Regenerative Energy Absorption by External Regeneration Resistance

If the regenerative energy exceeds the absorption capacity of the Servo Driver by itself, then external regeneration resistance must be connected. That resistance can be provided by either an External Regeneration Resistor or an External Regeneration Resistance Unit (for the R88D-WT60H to R88D-WT150H). A Resistor or Unit can be used alone or in combination with other Resistors/Units to provide the required regeneration processing capacity.



Caution

Connect the External Regeneration Resistor or External Regeneration Resistance Unit between the Servo Driver's B1 and B2 terminals. Check the terminal names carefully when connecting to the terminals. If the Resistor or Unit is connected to the wrong terminals it will damage the Servomotor.

Note 1. The External Regeneration Resistor can reach a temperature of approximately 120°C, so install it at a distance from heat-sensitive devices and wiring. In addition, a radiation shield must be installed according to the radiation conditions.

Note 2. The External Regeneration Resistance Unit is for use with R88D-WT60H to R88D-WT150H Servo Drivers only. It cannot be connected to other Servo Drivers.

Note 3. For external dimensions, refer to 2-9 External Regeneration Resistors/Resistance Units.

External Regeneration Resistors and External Regeneration Resistance Units

Specifications

Model	Resistance	Nominal capacity	Regeneration absorption at 120°C	Heat radiation	Thermal switch output
R88D-RR22047S External Regeneration Resistor	47 Ω ± 5%	220 W	70 W	t1.0 × □350 (SPCC)	Operating temperature: 170°C NC contact
R88D-RR88006 External Regeneration Unit	6.25 Ω ± 10%	880 W	180 W	—	—

Note The following external regeneration resistors are recommended products from another manufacturer, Iwaki Musen Kenkyusho Co., Ltd. For details, refer to the manufacturer’s documentation.

- RH120N50ΩJ 50 Ω ± 5% 30 W (Amount of regeneration at 120°C)
- RH300N50ΩJ 50 Ω ± 5% 75 W (Amount of regeneration at 120°C)
- RH500N50ΩJ 50 Ω ± 5% 100 W (Amount of regeneration at 120°C)

Combining External Regeneration Resistors (R88D-RR22047S)

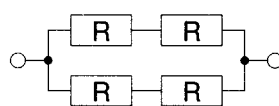
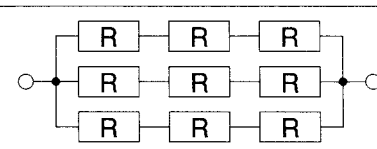
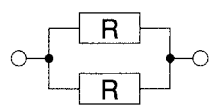
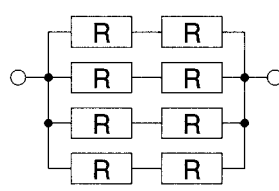
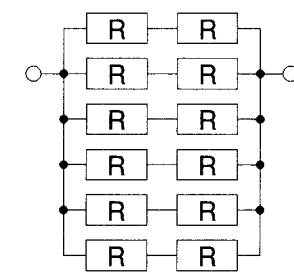
<p>1 70W (47Ω)</p> 	<p>2 280W (47Ω)</p> 	<p>3 630W (47Ω)</p> 
<p>4 140W (23.5Ω)</p> 	<p>5 560W (23.5Ω)</p> 	<p>6 840W (15.7Ω)</p> 

Note A combination cannot be used if the resistance is less than the minimum connection resistance for any given Servo Driver. Refer to the following table for the minimum connection resistance values for each Servo Driver, and select a suitable combination.

■ Servo Driver Minimum Connection Resistance and External Regeneration Resistor Combinations

Servo Driver	Minimum Connection Resistance (Ω)	External Regeneration Resistor Combinations
R88D-WTA3HL to R88D-WT01HL	40	1
R88D-WT02HL	40	1, 2
R88D-WTA3H to R88D-WT01H	40	1
R88D-WT02H/-WT04H	40	1, 2
R88D-WT05H to R88D-WT10H	40	1, 2, 3
R88D-WT15H	20	1, 2, 3, 4, 5
R88D-WT20H/-WT30H	12	1, 2, 3, 4, 5, 6
R88D-WT50H	8	1, 2, 3, 4, 5, 6
R88D-WT60H	5.8	1, 2, 3, 4, 5, 6 (or External Regeneration Resistance Unit)
R88D-WT75H/-WT150H	2.9	1, 2, 3, 4, 5, 6 (or External Regeneration Resistance Unit)

■ Wiring External Regeneration Resistance

● R88D-WTA3HL/-WTA5HL/-WT01HL/--WT02HL/-WTA3H/-WTA4H/-WTA5H/-WT01H/-WT02H/-WT04H

Connect an External Regeneration Resistor between the B1 and B2 terminals.

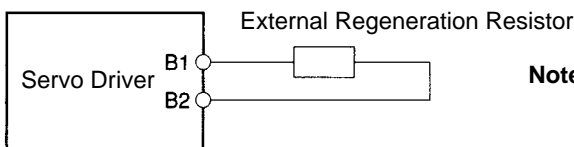

Note When using the R88A-RR22047S, connect the thermal switch output so that the power supply will be shut off when open.

● R88D-WT05H/-WT08H/-WT10H/-WT15H/-WT20H/-WT30H/-WT50H

Remove the short-circuit wiring between B2 and B2, and then connect an External Regeneration Resistor between the B1 and B2 terminals.

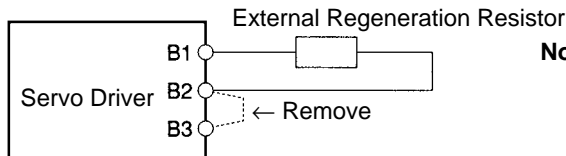

Note

1. The short-circuit wiring between B2 and B3 must be removed.
2. When using the R88A-RR22047S, connect the thermal switch output so that the power supply will be shut off when open.

● R88D-WT60H/-75H/-150H

Connect an External Regeneration Resistor or an External Regeneration Resistance Unit between the B1 and B2 terminals.

Note The R88D-WT60H to R88D-WT150H models do not have built-in regeneration processing circuitry, so external resistance must be connected.

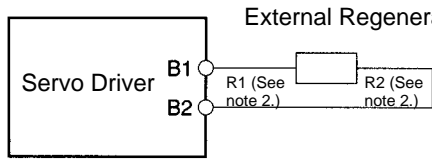

- Note**
1. When using the R88A-RR22047S, connect the thermal switch output so that the power supply will be shut off when open.
 2. For the R88A-RR88006 (R1 and R2 have no polarity).
 3. Connect an External Regeneration Resistor or External Regeneration Resistance Unit either alone or in combination, according to the required regeneration processing capacity.

3-4 Adjustments and Dynamic Braking When Load Inertia Is Large

The value that is given for the Servomotor's applicable load inertia is the value that will not damage the Servo Driver's internal circuits (dynamic brake circuit, regenerative circuit, etc.) when control is basically stable and the operating status is normal. When the Servomotor is used at the applicable load inertia or below, there are certain operating conditions and precautions that must be observed when making adjustments and using the dynamic brake. For details on regenerative energy processing, refer to 3-3 *Regenerative Energy Absorption*.

3-4-1 Adjustments When Load Inertia Is Large

Operation is possible with a large load inertia as long as the load torque is within a range that allows Servo Driver control (i.e., no larger than the rated torque and within the electronic thermal range: these depend on the motor speed and acceleration/deceleration). If the load inertia ratio is large, however, adjustment becomes difficult using only the rigidity setting and autotuning, as shown below. The following table lists the adjustment criteria according to the load inertia.

Load inertia ratio	Adjustment criteria
Below 500%	Adjustment is possible using mainly the factory settings or the rigidity setting function (Fn001).
500% to 1,000%	Adjustment is possible using mainly the rigidity setting and autotuning.
1,000% to 3,000%	Adjustment may be possible using the rigidity setting and autotuning, but it may be necessary to manually adjust settings such as the gain.
Above 3,000%	Adjustment will be difficult using the rigidity setting and autotuning. Set the load inertia based on mechanism settings, and manually adjust the gain.

3-4-2 Dynamic Braking When Load Inertia Is Large

Dynamic braking is used to brake the Servomotor by consuming rotational energy using a resistor. The Servomotor's rotational energy can be found by using the following equation.

$$\text{Servomotor rotational energy} = (1/2 \times J \times \omega^2) = 1/2 \times J \times (2 \times \pi)^2 \times (N/60)^2$$

J: Load inertia + Servomotor rotor inertia

N: Servomotor speed [r/min]

Therefore, if the load inertia ratio is large and the motor speed is high, the load on the dynamic brake circuit will be great and there will be a risk of burnout. Burnout may also occur if the dynamic brake is used repeatedly within a short period of time. Do not use the dynamic brake under conditions where the maximum speeds or load inertia ratios shown in the following table are exceeded. For operating conditions other than these, use the following equation: $1/2 \times J \times \omega^2 = \text{Constant}$.

Servomotor	Load inertia ratio	Application conditions
3,000-r/min Servomotors, 30 to 400 W	3,000% max.	Maximum speed of 5,000 r/min
3,000-r/min Servomotors, 750 W	2,000% max.	Maximum speed of 5,000 r/min
3,000-r/min Servomotors, 1 k to 2 kW	1,000% max.	Maximum speed of 5,000 r/min
3,000-r/min Servomotors, 3 kW	1,000% max.	Maximum speed of 4,000 r/min
3,000-r/min Servomotors, 4 kW, 5 kW	1,000% max.	Maximum speed of 5,000 r/min
3,000-r/min Flat-type Servomotors, 100 W	2,500% max.	Maximum speed of 5,000 r/min
3,000-r/min Flat-type Servomotors, 200 W or 400 W	1,500% max.	Maximum speed of 5,000 r/min
3,000-r/min Flat-type Servomotors, 750 W or 1.5 kW	1,000% max.	Maximum speed of 5,000 r/min
1,000-r/min Servomotors, 300 W to 1.2 kW	1,000% max.	Maximum speed of 2,000 r/min
1,000-r/min Servomotors, 2 kW	1,000% max.	Maximum speed of 1,500 r/min
1,000-r/min Servomotors, 3 kW	1,000% max.	Maximum speed of 1,000 r/min
1,000-r/min Servomotors, 4 kW	1,000% max.	Maximum speed of 2,000 r/min
1,000-r/min Servomotors, 5 kW	1,000% max.	Maximum speed of 1,500 r/min
1,500-r/min Servomotors, 450 W, 850 W	1,000% max.	Maximum speed of 3,000 r/min
1,500-r/min Servomotors, 1.3 kW	1,000% max.	Maximum speed of 2,500 r/min
1,500-r/min Servomotors, 1.8 kW	1,000% max.	Maximum speed of 2,000 r/min
1,500-r/min Servomotors, 2.9 kW	1,000% max.	Maximum speed of 1,500 r/min
1,500-r/min Servomotors, 4.4 kW	1,000% max.	Maximum speed of 2,500 r/min
1,500-r/min Servomotors, 5.5 kW	1,000% max.	Maximum speed of 2,000 r/min
1,500-r/min Servomotors, 7.5 kW	700% max.	Maximum speed of 2,000 r/min
1,500-r/min Servomotors, 11 kW, 15 kW	500% max.	Maximum speed of 1,500 r/min

Note If the dynamic brake is stopped at a speed higher than the speed specified above under *Application conditions*, the dynamic brake resistor may weld.

For Servomotors of 1.5 kW or less, observe the following precautions if there is a possibility of the power being turned ON while the Servomotor is rotating.

In Servomotors of 1.5 kW or less, the dynamic brake circuit uses a relay. Normally, if an alarm occurs while the Servo is OFF, the dynamic brake operates according to the function selection application switch (Pn001.0, 1) when drive prohibition is being input. At 1.5 kW or less, however, the dynamic brake operates regardless of this setting even if the main circuit power supply or the control power supply is OFF.

Current flows to the relay while the dynamic brake is operating. If 2 (Stop Servomotor by free run) is selected for the function selection application switch (Pn001.0: Stop selection for alarm generation with Servo OFF), the relay turns OFF when the power is turned ON again.

If the power is turned from OFF to ON while the Servomotor is rotating, the relay operates while current is flowing to it. This may cause the relay contacts to fuse.

For Servomotors of 1.5 kW or less, if there is a possibility of the power being turned ON during Servomotor rotation, either set 0 (Stop Servomotor by dynamic brake) for the function selection application switch (Pn001.0: Stop selection for alarm generation with Servo OFF) or make sure that the power will not be turned ON until the Servomotor has stopped.

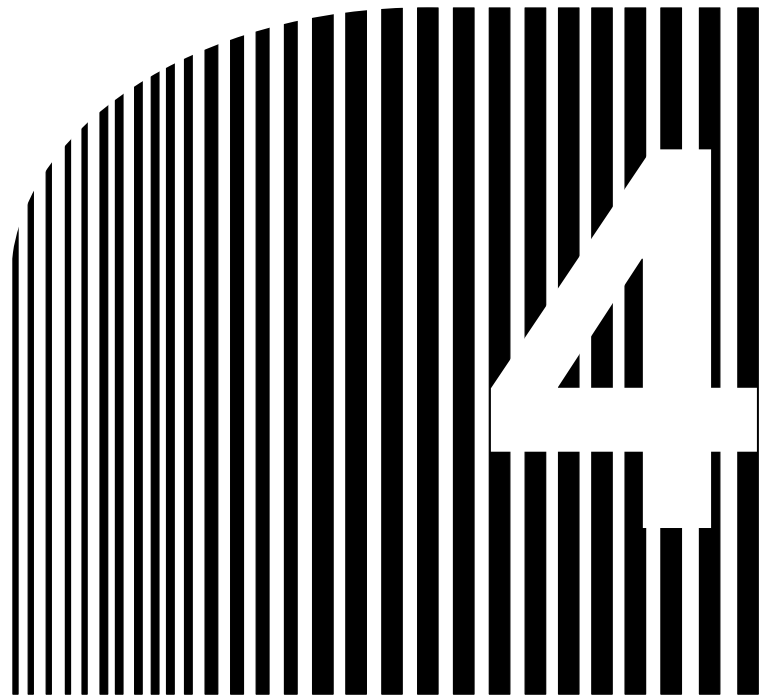



Chapter 4

• Operation •

- 4-1 Operational Procedure
- 4-2 Preparing for Operation
- 4-3 Trial Operation
- 4-4 User Parameters
- 4-5 Operation Functions
- 4-6 Trial Operation Procedure
- 4-7 Making Adjustments
- 4-8 Advanced Adjustment Functions
- 4-9 Using Displays
- 4-10 Using Monitor Output
- 4-11 System Check Mode

Precautions

-  **Caution** Confirm that there will be no effect on the equipment, and then perform a test operation. Not doing so may result in equipment damage.

-  **Caution** Check the newly set parameters for proper execution before actually running them. Not doing so may result in equipment damage.

-  **Caution** Do not make any extreme adjustments or setting changes. Doing so may result in unstable operation and injury.

-  **Caution** Separate the Servomotor from the machine, check for proper operation, and then connect to the machine. Not doing so may cause injury.

-  **Caution** When an alarm occurs, remove the cause, reset the alarm after confirming safety, and then resume operation. Not doing so may result in injury.

-  **Caution** Do not use the built-in brake of the Servomotor for ordinary braking. Doing so may result in a malfunction.

4-1 Operational Procedure

After mounting, wiring, and connecting a power supply, check the operation of the Servomotor and Servo Driver. Then make the function settings as required according to the use of the Servomotor and Servo Driver. If the parameters are set incorrectly, there is a risk of an unforeseen Servomotor operation. Set the parameters in accordance with the instructions in this manual.

1. Mounting and installation

Install the Servomotor and Servo Driver according to the installation conditions. (Do not connect the Servomotor to the mechanical system before checking the no-load operation.) Refer to *3-1 Installation Conditions*.

2. Wiring and connections

Connect to power supply and peripheral devices. Specified installation and wiring requirements must be satisfied, particularly for models conforming to the EC Directives. Refer to *3-2 Wiring*.

3. Preparing for operation

Before turning ON the power supply, check the necessary items. Check by means of the displays to see whether there are any internal errors in the Servo Driver. If using a Servomotor with an absolute encoder, first set up the absolute encoder. Refer to *4-2-2 Absolute Encoder Setup and Battery Changes*.

4. Checking operation

Check the operation of the Servomotor and Servo Driver alone by performing a jogging operation without a load. Refer to *4-4-3 Important Parameters*.

5. Function settings

By means of the user parameters, set the functions according to the operating conditions. Refer to *4-4-4 Parameter Details and 4-5 Operation Functions*.

6. Trial operation

Turn the power OFF then ON again to enable the parameter settings. If using a Servomotor with an absolute encoder, set up the absolute encoder and set the Motion Control Unit's initial parameters. Turn ON the power, and check to see whether protective functions such as emergency stop and operational limits are working reliably. Check operation at both low speed and high speed (using instructions from the Host Controller). Refer to *4-6 Trial Operation Procedure*.

7. Adjustments

Manually adjust the gain as required. Further adjust the various functions to further improve the control performance as required. Refer to *4-7 Making Adjustments and 4-8 Advanced Adjustment Functions*.

8. Operation

Operation can now begin. If any trouble should occur, refer to *Chapter 5 Troubleshooting*.

4-2 Preparing for Operation

This section explains the procedure following installation and wiring of the Servomotor and Servo Driver, to prepare the mechanical system for operation. It explains what you need to check both before and after turning ON the power. It also explains the setup procedure required if using a Servomotor with an absolute encoder.

4-2-1 Turning Power ON and Checking Indicators

■ Items to Check Before Turning ON the Power

● Checking Power Supply Voltage

- Check to be sure that the power supply voltage is within the ranges shown below.

R88D-WT□HL (Single-phase 100 V AC input)

Main-circuit power supply: Single-phase 100/115 V AC (85 to 127 V) 50/60 Hz

Control-circuit power supply: Single-phase 100/115 V AC (85 to 127 V) 50/60 Hz

R88D-WTA3H/A5H/01H/02H/04H (Single-phase 200 V AC input)

Main-circuit power supply: Single-phase 200/230 V AC (170 to 253 V) 50/60 Hz

Control-circuit power supply: Single-phase 200/230 V AC (170 to 253 V) 50/60 Hz

R88D-WT05H/08H/10H/15H/20H/30H/50H/60H/75H/150H (Three-phase 200 V AC input)

Main-circuit power supply: Three-phase 200/230 V AC (170 to 253 V) 50/60 Hz

Control-circuit power supply: Single-phase 200/230 V AC (170 to 253 V) 50/60 Hz

● Checking Terminal Block Wiring

- The main-circuit power supply inputs (L1/L2 or L1/L2/L3) and the control-circuit power supply inputs (L1C/L2C) must be properly connected to the terminal block.
- The Servomotor's red (U), white (V), and blue (W) power lines and the yellow/green ground wire (\perp) must be properly connected to the terminal block.

● Checking the Servomotor

- There should be no load on the Servomotor. (Do not connect to the mechanical system.)
- The power lines at the Servomotor must be securely connected.

● Checking the Encoder Connectors

- The Encoder Cable must be securely connected to the Encoder Connector (CN2) at the Servo Driver.
- The Encoder Cable must be securely connected to the Encoder Connector at the Servomotor.

● Checking the Control Connectors

- The Control Cable must be securely connected to the I/O Control Connector (CN1).
- The RUN command (RUN) must be OFF.

● **Checking Parameter Unit Connections**

- The Parameter Unit (R88A-PR02W) must be securely connected to the CN3 connector.

■ **Turning ON Power**

- First carry out the preliminary checks, and then turn ON the control-circuit power supply. It makes no difference whether or not the main-circuit power supply is also turned ON.
- The $\overline{\text{ALM}}$ output will take approximately 2 seconds to turn ON after the power has been turned ON. Do not attempt to detect an alarm using the Host Controller during this time (when power is being supplied with the Host Controller connected).

■ **Checking Displays**

- When the power is turned ON, one of the codes shown below will be displayed at either the indicators or the Parameter Unit.

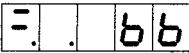
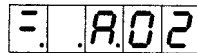





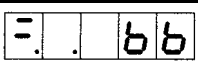

Normal (Base Block)	Error (Alarm Display)
	

Note 1. “bb” (baseblock) means that the Servomotor is not receiving power.

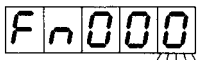
Note 2. The alarm code (the number shown in the alarm display) changes depending on the contents of the error.

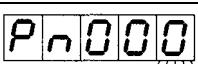
Note 3. When using a Servomotor with an absolute encoder for the first time, A.81 (backup error) will be displayed. Clear this error by setting up the absolute encoder. (Refer to 4-2-2 *Absolute Encoder Setup and Battery Changes*).

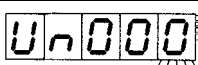
- If the display is normal (i.e., no errors), manually turn the Servomotor shaft forward and reverse, and check to be sure that it agrees with the positive and negative on the speed display. Display the speed feedback in Monitor Mode using the setting switches on the front panel, or the Parameter Unit, and turn the Servomotor shaft forward and reverse.

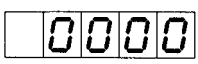
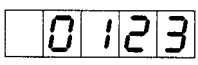
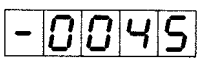
PR02W operation	Front panel key operation	Display example	Explanation
			(Baseblock display)
			Press the MODE/SET Key to change to System Check Mode.
			Press the MODE/SET Key once again to change to Setting Mode.
			Press the MODE/SET Key once again to change to Monitor Mode.
	 (Press and hold for 1 s min.)		Press the DATA Key to display the Servomotor speed (r/min). Un000 is the speed feedback monitor number. (See note 1.)
Rotate the Servomotor shaft forwards by hand.			Rotate the Servomotor shaft forward to check that the load is displayed. (Refer to the diagram below.)
Rotate the Servomotor shaft in reverse by hand.			Rotate the Servomotor shaft in reverse to check that the load is displayed. (Refer to the diagram below.)

Note 1. If using the operation keys on the front panel, press and hold the DATA Key for one second or longer.

Note 2. Refer to 4-3-1 Operation Details for details of operations.

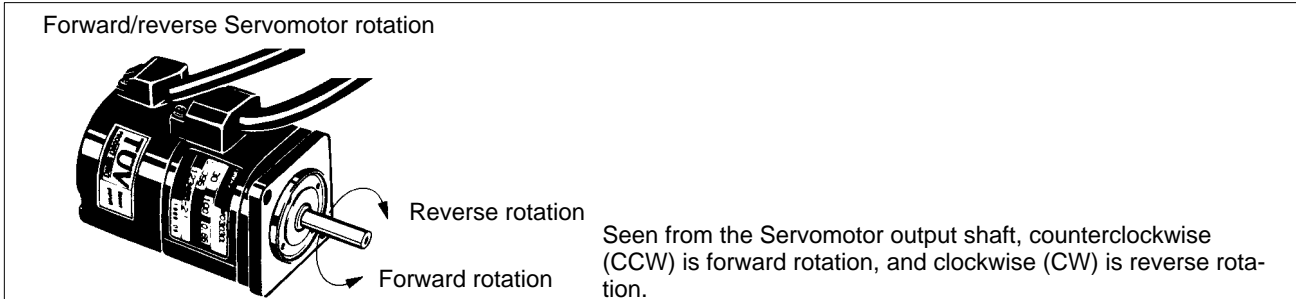

If the direction of Servomotor rotation and the speed feedback monitor symbols do not agree, the Encoder Cable may be incorrectly wired. Check the conduction for each cable.

- If there is an error, refer to Chapter 5 Troubleshooting and take the necessary countermeasures.

4-2-2 Absolute Encoder Setup and Battery Changes

You must set up the absolute encoder if using a Servomotor with an absolute encoder. Perform the setup if connecting a Battery Unit (R88A-BAT01W) to an absolute encoder for the first time, or when setting the mechanical rotation data to 0 for a trial operation.

■ Absolute Encoder Setup Procedure

- Be sure to follow this procedure carefully. Any mistakes in carrying out this procedure could result in faulty operation.

● Absolute Encoder Setup (Fn008) in System Check Mode

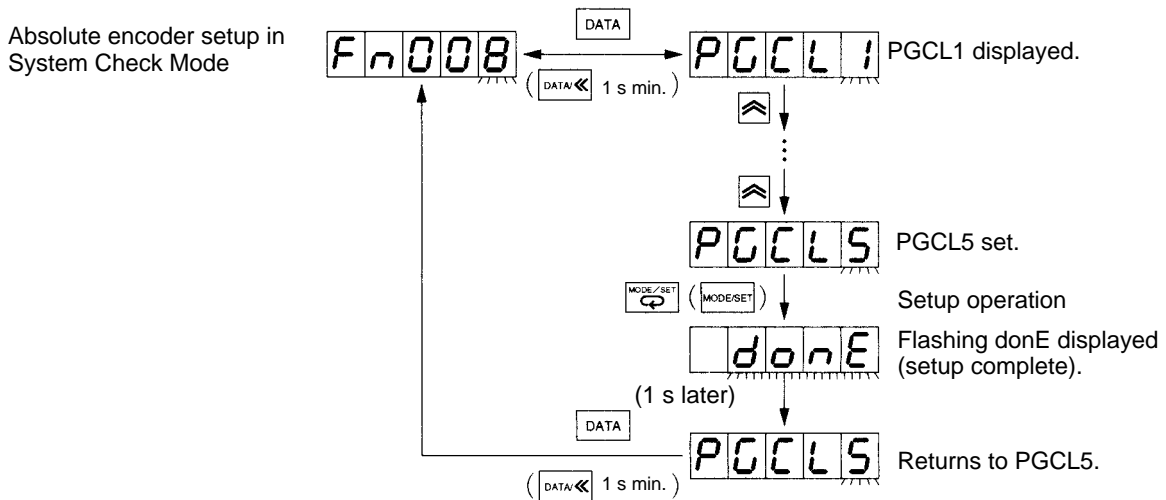

● Operation Procedure

PR02W operation	Front panel key operation	Display example	Explanation
			Status Display Mode. (See note.)
			Press the MODE/SET Key to change to System Check Mode.
			Press the Up or Down Key to select function Fn008.
			Press the DATA Key (front panel: DATA Key for 1 s min.) to enter the absolute encoder setup functions. PGCL1 will be displayed.
			Press the Up Key to display PGCL5.
			Press the MODE/SET Key to set up the absolute encoder. When setup is complete, “donE” will flash for approximately 1 s.
(Approx. 1 s later)			After “donE” has been displayed, the display will return to “PGCL5.”
			Press the DATA Key (front panel: DATA Key for 1 s min.) to display the System Check Mode function code.

Note When connecting a Servomotor with an absolute encoder and turning ON the power for the first time, A.81 (backup error) will be displayed.

● Turn ON the Power

The alarm (A.81) will not be cancelled with the setup operation. Turn OFF the power (and check that the power indicator is not lit), then turn ON the power again to cancel the alarm. After the power is turned ON again, as long as there is no error, the setup procedure is complete at this point. If an alarm (A.81) occurs, repeat the previous step.

■ Additional Setup Operations

● Trial Operation Setup

- The preceding setup is necessary to check the Servomotor and Servo Driver operations (without a load). When connecting the Servomotor and mechanical system for a trial operation, the absolute encoder may rotate excessively. If that occurs, perform the setup once again.
- When connecting to the CV500-MC221/421 or C200H-MC221 Motion Control Unit, carry out the setup close to the mechanical origin. An error will be generated if the absolute data exceeds ±32,767 pulses when making the initial settings for the CV500-MC221/MC421 or C200H-MC221 Motion Control Unit (This limitation does not apply to the CS1W-MC221/MC241 Motion Control Unit).

Note The number of rotations and the output range for the OMNUC W-series absolute encoders are different from the previous models (U series).

W series: Number of rotations and output range: –32,768 to 32,767

U series: Number of rotations and output range: –99,999 to 99,999

Set the operating range within the number of rotations and output range.

• Setup when Replacing Battery Unit

- If an alarm (A.81) occurs after replacing the Battery Unit, repeat the setup from the start.
- When connecting to the CV500-MC221/421 or C200H-MC221 Motion Control Unit, carry out the set-up close to the mechanical origin (This limitation does not apply to the CS1W-MC221/MC241 Motion Control Unit). The rotation data will be different from before the battery was replaced, so reset the initial Motion Control Unit parameters (including for the CS1W-MC221/MC421 Motion Control Unit).

Note It is not necessary to set up and reset the initial parameters for the Motion Control Unit if no alarm occurs after the Battery Unit has been replaced. If the Battery Unit is replaced using the correct procedure before it wears out, an error alarm will not be generated. Refer to *4-2-2 Absolute Encoder Setup and Battery Changes* for Battery Unit service life and replacement method.

• Other Cases where Setup Is Required

- If the Encoder Cable is removed from the connector (on either the Servo Driver or Servomotor side), the data within the absolute encoder will be cleared. In this case, perform the setup once again.
- If the Battery Unit has completely worn down, the data within the absolute encoder will be cleared. In this case, replace the Battery Unit and perform the setup once again.

4-3 Trial Operation

This section explains basic operations and the jog operation for the Servomotor and Servo Driver.

4-3-1 Operation Details

- The key operations for the R88A-PR02W Parameter Unit and the Servo Driver front panel setting keys vary depending on the functions used. The same settings and operations are possible with either method.
- If a Parameter Unit is connected, the indicators (7-segment LEDs) on the front panel will flash, and the settings keys cannot be used.

■ Keys and Functions

Parameter Unit

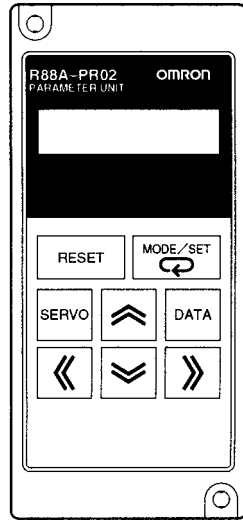

Servo Driver front panel settings area

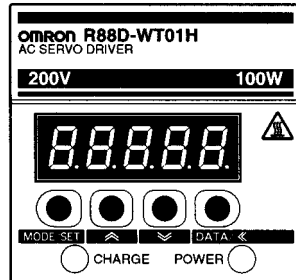

PR02W	Front panel keys	Function
RESET	[↑] + [↓]	Alarm reset
MODE/SET	MODE/SET	Mode switching Data memory
SERVO	MODE/SET	Servo ON/OFF during jog operations
DATA	DATA<<	Switching between parameter display and data display; data memory
[↑]	[↑]	Increments parameter numbers and data values.
[↓]	[↓]	Decrements parameter numbers and data values.
[<<]	DATA<<	Left shift for operation digits
[>>]		Right shift for operation digits

■ Modes

OMNUC W-series AC Servo Drivers have the following four modes.

Mode	Function
Status Display Mode	This mode displays the internal Servo Driver status using bit display (LED lit/not lit) and symbol display (7-segment 3-digit LEDs). Bit display: Control-circuit power supply ON display, main-circuit power supply ON display, baseblock, in position, speed conformity, rotation detection, command pulses being input, speed command being input, torque command being input, deviation counter reset signal being input Symbol display: Baseblock (bb), operating (run), forward rotation prohibited (Pot), reverse rotation prohibited (not), alarm display (A.□□), key operation disabled (nO OP), setting error (Error)
System Check Mode	Alarm history display, rigidity setting during online auto-tuning, jog operation, Servomotor origin search, user parameter initialization, alarm history data clear, online auto-tuning results storage, absolute encoder setup, automatic command offset adjustment, manual command offset adjustment, manual analog monitor output offset adjustment, analog monitor output scaling, automatic Servomotor current detection offset adjustment, manual current detection offset adjustment, password setting, Servomotor parameters check, version check, absolute encoder rotation setting change
Settings Mode	This is the mode for setting and checking user parameters (Pn□□□)
Monitor Mode	This mode monitors the I/O status for each signal and internal Servo Driver data. Speed feedback, speed commands, torque commands, number of pulses from Z-phase, electrical angle, internal signal monitor, external signal monitor, command pulse speed display, position displacement, cumulative load rate, regeneration load rate, dynamic brake load rate, input pulse counter, feedback pulse counter

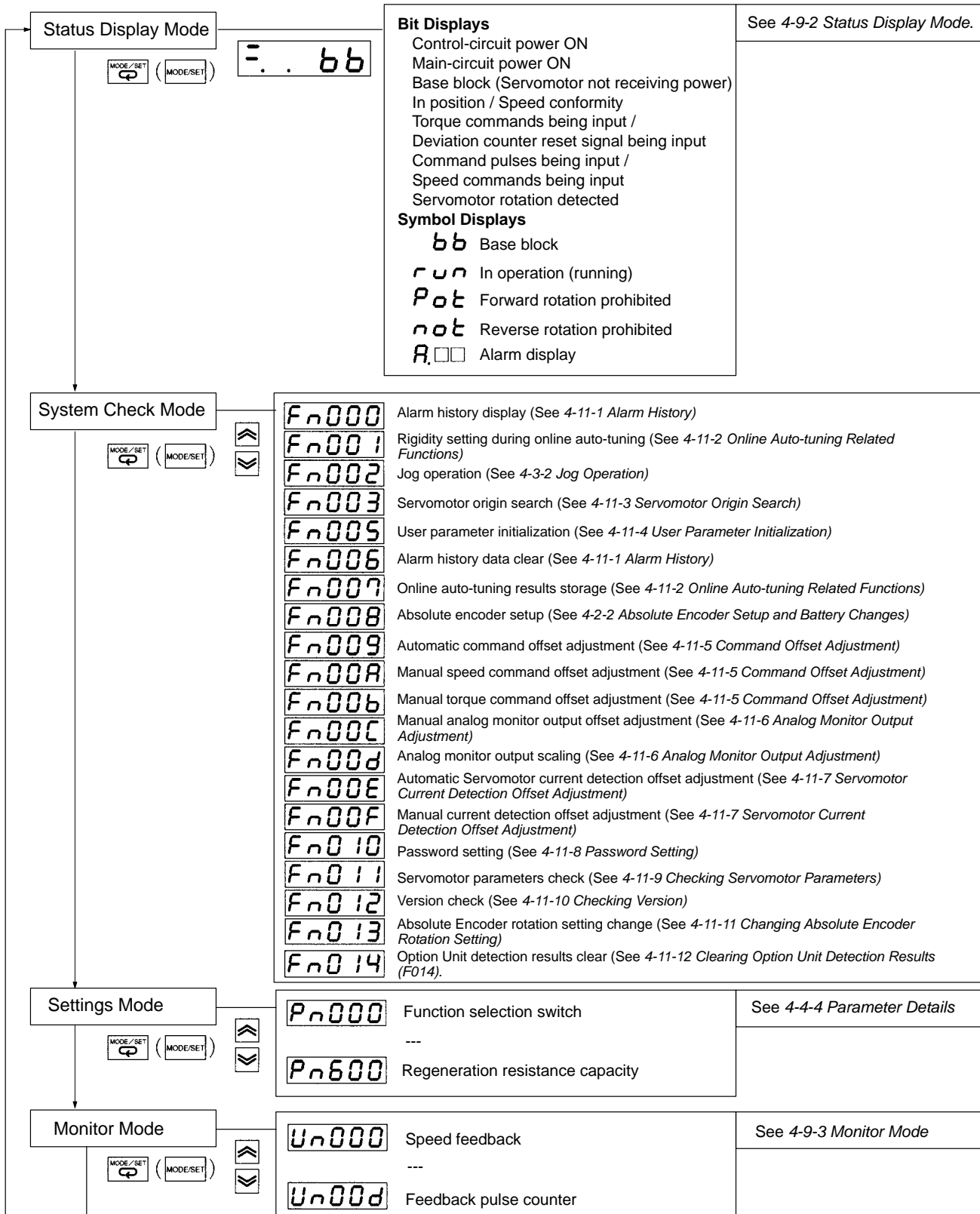

■ Mode Changes and Display Contents

- Use the MODE/SET Key to change modes.
- Use the Up and Down Keys to change parameter and monitor numbers.

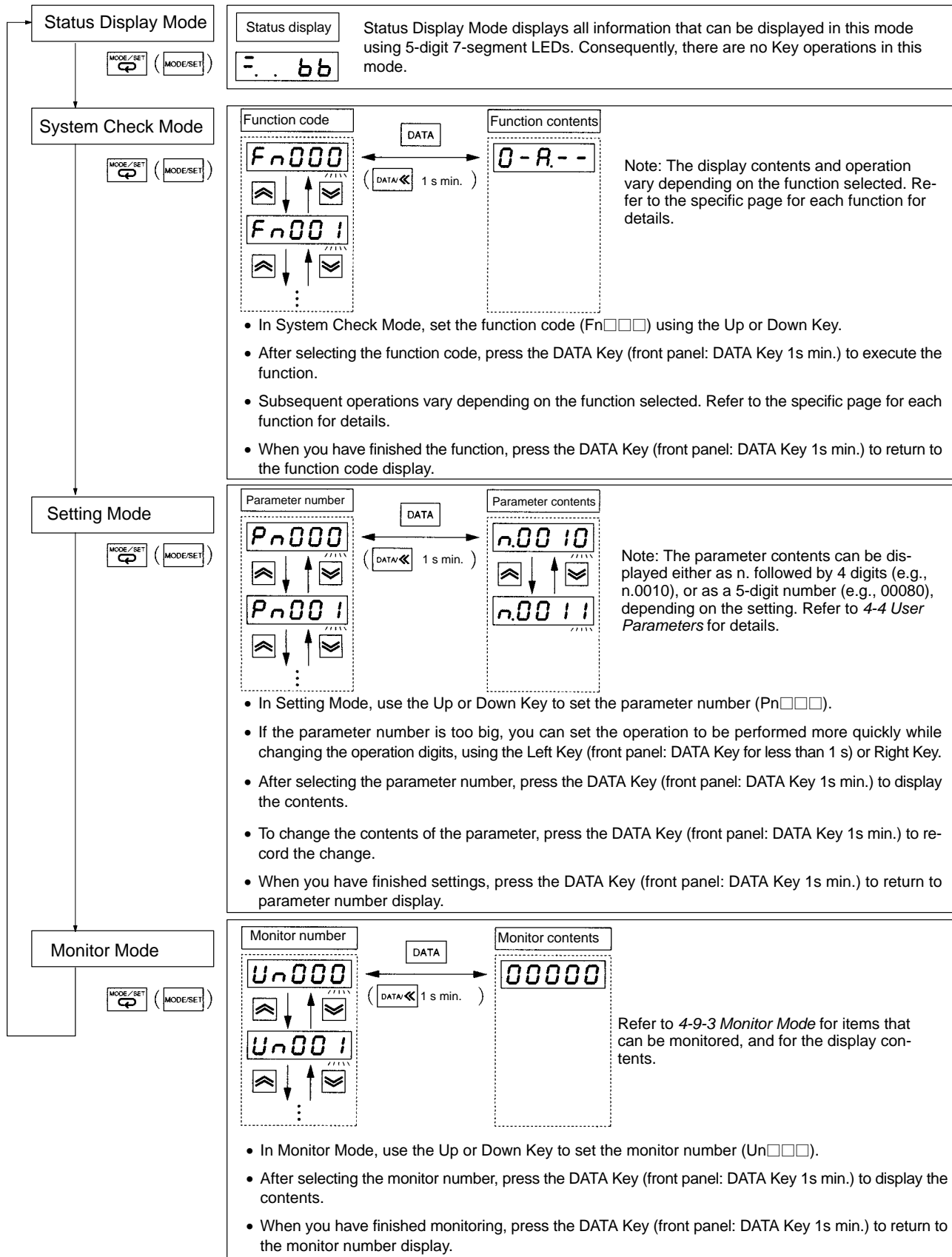

■ Basic Operations in Each Mode



- Note 1.** The “.....” mark beneath a display example indicates the numbers are flashing. (Digits that can be changed flash).
- Note 2.** In this manual, when Parameter Unit keys and front panel keys are shown together, the Parameter Unit key is given first, and the front panel key is given in parentheses as follows:  ().
- Note 3.** Press and hold the Up or Down Key to increment or decrement rapidly (auto-increment function).
- Note 4.** The function selected depends on the length of time you press and hold the DATA Key on the Servo Driver front panel (functions as the Left Key when held for less than 1 s, and as the DATA Key when held for 1 s or longer).

4-3-2 Jog Operation

- Jog operations rotate the Servomotor in a forward or reverse direction using the operation keys.
- For safety's sake, only use the jog operation when the Servomotor is unloaded (i.e., when the shaft is not connected to the mechanical system). Also, to prevent the Servomotor rotating sideways, fasten the Servomotor mounting surface firmly to the machinery.
- Use the jog operation when the power to the Host Controller is turned OFF, or the Host Controller is not connected.

■ Using the Jog Operation

- The jog operation is System Check Mode function code Fn002.
- You can use the keys to turn the Servomotor ON or OFF, or rotate the Servomotor forward and reverse.
- The default jog operation speed is 500 r/min. You can change the speed using user parameter number Pn304 (jog speed).

● First Try 500 r/min.

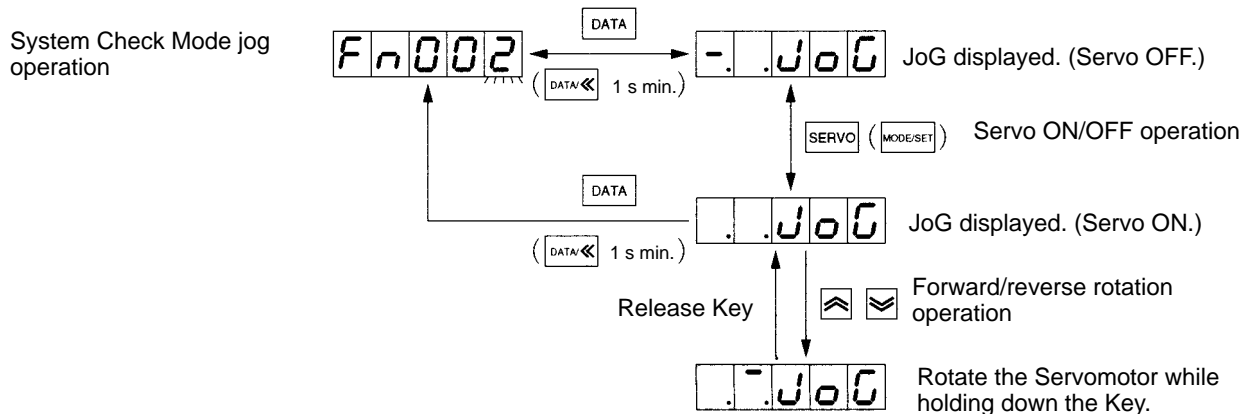

● Operation Procedure

PR02W	Front panel key operation	Display example	Explanation
			Press the MODE SET Key to change to System Check Mode.
			Select function code Fn002 using the Up or Down Key. The digits you can operate will flash.
			Press the DATA Key (front panel: DATA Key for 1 s min.). The jog operation will be enabled.
			Turn ON the Servomotor.
			Press the Up Key. While the Up Key is held down, the Servomotor will rotate forwards at 500 r/min.
			Press the Down Key. While the Down Key is held down, the Servomotor will rotate in reverse at 500 r/min.
			Turn OFF the Servomotor.
			Press the DATA Key (front panel: DATA Key for 1 s min.) to end the jog operation and return to the function code display.

Note 1. You can end the jog operation with the Servomotor turned OFF. When the display returns to Fn002, the Servomotor will turn OFF automatically.

Note 2. The 2-digit LED bit display before the “JoG” display is the same as the bit display in Status Display Mode.

● Changing the Rotation Speed

- The default setting for user parameter number Pn304 (jog speed) is 00500 (500 r/min.). You can change this setting to change the rotation speed during a jog operation.
- Try changing the jog speed setting to 01000 (1000 r/min.)

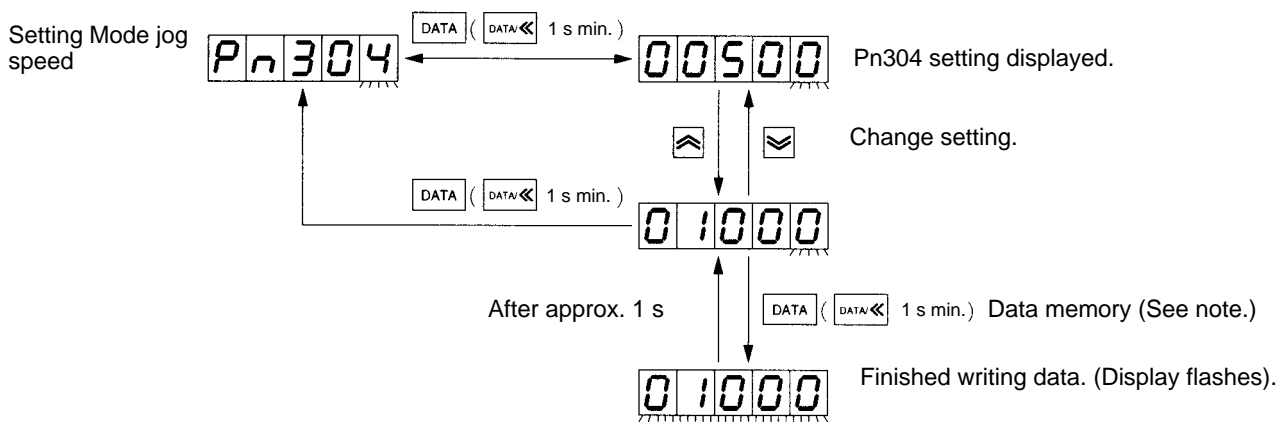

Note When changing the setting, first press the DATA Key (front panel: DATA Key for 1 s min.) to write the data to memory, then press the Key again to return to the parameter number display. You cannot return to the parameter number display without saving the changed data to memory.

● Operation Procedure

PR02W	Front panel key operation	Display example	Explanation
			(System Check Mode)
			Press the MODE/SET Key to change to Setting Mode.
			Press the Up or Down Key to set parameter number Pn304. (See note 1.)
			Press DATA Key (front panel: DATA Key for 1 s min.). The parameter number Pn304 setting will be displayed.
			Press the Up or Down Key to change the setting to 01000.
			Press the DATA Key (front panel: DATA Key for 1 s min.) to save the data to memory (the setting display will flash for approximately 1 s).
(Approx. 1 s later)			After the display has finished flashing, it will return to normal.
			Press the DATA Key (front panel: DATA Key for 1 s min.) to return to the parameter number display.

Note 1. The digits you can operate will flash.

Note 2. Change the jog speed setting as described, then perform jog operations as before. Confirm that the rotation speed is faster than before.

● Procedure for Changing Settings

- You can use various operations to change the parameter number and parameter settings. Use these operations as needed to shorten the time required for a setting operation.
- Try changing the jog speed setting using various different operations.

Note Do not change any other parameter settings at this stage. Before changing other parameter settings, make sure you read and fully understand *4-4 User Parameters*.

Changing the Setting Using the Up and Down Keys

- The digits that can be changed will flash.
- Press the Up Key to increment the setting, and press the Down Key to decrement the setting.

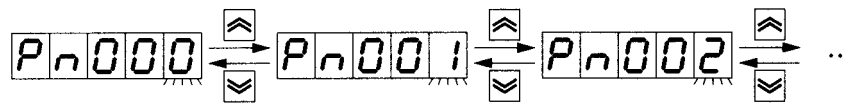

- Press and hold the keys to increment and decrement rapidly (auto-increment function).

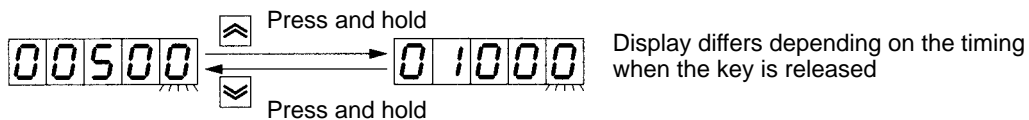

Changing the Setting while Changing the Operation Digits using the Left Key and Right Keys

- Press the Left Key (front panel: DATA Key for less than 1 s) to shift the operation digit to the left, and press the Right Key to shift the operation digit to the right.

Note 1. There is no right shift function for the front panel keys.

Note 2. Press the DATA Key on the front panel for less than 1 s. Pressing the Key for 1 s or more causes the Unit to recognize the Key as the DATA Key.

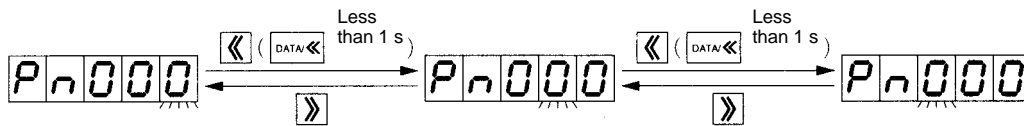

- The function code, parameter number, and monitor number are the rightmost three digits of the digits that can be changed. Press the Left Key (front panel: DATA Key for less than 1 s) to change the operation digit as follows:

Units (digit No. 0) to 10s (digit No. 1) to 100s (digit No. 2) to units (digit No. 0), etc.

Note This manual uses digit numbers shown above to denote the position of the digit in question in the 5-digit display. The rightmost digit is digit No. 0, and the leftmost digit is digit No. 4. Also, you can change 4 or 5 digits in the parameter setting data. Press the Left Key (front panel: DATA Key for less than 1 s) to shift the operation digit to the left in the same way. After you reach the leftmost digit you can change, the display returns to digit No. 0.

- Use the following operation to shift the operation digit if, for example, you want to change the setting from 00500 to 01000.

Select operation digit No. 2 using the Left Key (front panel: DATA Key for less than 1 s), and then press the Up Key 5 times at digit No. 5. You can shorten the operation time by performing operations in this way.

- You can shorten the operation time by using the operation digit shift function, but the digit number from which you start the operation depends on which current setting (display contents) you want to change. Try a variety of different procedures to find the best one.

4-4 User Parameters

Set and check the user parameters using the Setting Mode. Make sure you fully understand the parameter meanings and how to set them before setting user parameters in the system. Some parameters are enabled by turning OFF the Unit, then turning it ON again. When changing these parameters, turn OFF the power (check that the power lamp is not lit), then turn ON the power again.

4-4-1 Setting and Checking Parameters

■ Operation Overview

- Use the following procedure to set and check parameters.
 - Go into Setting Mode: ()
 - Set the parameter number (Pn□□□□): , , (less than 1 s),
 - Display the parameter setting: (for 1 s min.)
 - Change the setting: , , (less than 1 s), (Not required for checking only.)
 - Save the changed setting to memory: (for 1 s min.) (Not required for checking only.)
 - Return to parameter number display: (for 1 s min.)

■ Operation Procedure

● Going into Setting Mode

PR02W operation	Front panel key operation	Display example	Explanation
			(Status Display Mode)
			Press the MODE/SET Key to go into Setting Mode

● Setting the Parameter Number

PR02W operation	Front panel key operation	Display example	Explanation
, , ,	, , (less than 1 s)		Set the parameter number you want to set or check. If the parameter number is too big, you can set the operation to be performed more quickly while changing the operation digits, using the Left Key (front panel: DATA Key for less than 1 s) or Right Key.

- Unused parameter numbers are basically not displayed. For example, if you press the Up Key on operation digit No. 0 while displaying parameter number Pn005, the display will change to Pn100 (as

there are no Pn006 to Pn099). For this reason, if, for example, you change Pn000 to Pn207 using the Shift Key, you can perform the operation more quickly by making the change starting from the leftmost digit side (i.e., digit No. 2).

● **Displaying Parameter Settings**

PR02W operation	Front panel key operation	Display example	Explanation
			(The parameter number is displayed.)
	 (1 s min.)		Press the DATA Key (front panel: DATA Key for 1 s min.) to display the parameter setting.

Note Parameter settings can be displayed as 5 digits as shown above, or as “n.” followed by 4 digits, i.e., as n.□□□□.

● **Changing Settings**

- The following operation is not necessary if you are only checking the settings.
- Parameter settings can be set as 5 digits, or as 4 digits (displayed as n.□□□□). When set as 4 digits, each digit in the parameter has a meaning, so the parameter cannot be set just by using the Up and Down Keys. Be sure to set the parameter using the Left Key (front panel: DATA Key for less than 1 s), and Right Key.

Types of parameters	Display example	Explanation
Function selection switches (Pn000 to Pn003) Speed control setting (Pn10b) Online auto-tuning setting (Pn110) Position control settings 1 to 3 (Pn200, Pn207, Pn218) Torque command setting (Pn408) I/O signal selection (Pn50A to 513)		For parameters displayed as “n.□□□□”, each of the 4 digits after the “n.” indicate different function settings (i.e., 4 different function settings are performed using 1 parameter No.) For these parameters, each digit must be set separately.
All other user parameters		Parameters displayed using 5 digits indicate a single value. These parameters can be set from the lowest point to the highest point within the setting range using just the Up or Down Key. You can also set the digits separately.

Example of a 5-digit Parameter Setting

PR02W operation	Front panel key operation	Display example	Explanation
			(Present setting)
	 (less than 1 s)		Change the setting using the Up or Down Key. If the setting is too large, you can set the operation to be performed more quickly while changing the operation digits, using the Left Key (front panel: DATA Key for less than 1 s) or Right Key.

Example of an n. + 4 Digits Parameter Setting

PR02W operation	Front panel key operation	Display example	Explanation
			(Present setting)
		 Digit No. 3 Digit No. 0	Set the digit No. to be operated using the Left Key (front panel: DATA Key for less than 1 s) or Right Key. You cannot use only the Up and Down Keys.

Saving the Changed Setting to Memory

- The following operation is not necessary if you are only checking the settings.

PR02W operation	Front panel key operation	Display example	Explanation
			Press the DATA Key (front panel: DATA Key for 1 s min.) to save the data to memory (the setting display will flash for approximately 1 s).
(After approx. 1 s)			After the display has finished flashing, it will return to normal.

• Return to Parameter Number Display

PR02W operation	Front panel key operation	Display example	Explanation
			Press the DATA Key (front panel: DATA Key for 1 s min.) to return to the parameter No. display.

4-4-2 Parameter Tables

- Some parameters are enabled by turning OFF the Unit, then turning it ON again. (See the tables below.) When changing these parameters, turn OFF the power (check that the power lamp is not lit), then turn ON the power again.
- The specific digit number of a parameter for which each digit number must be set separately is displayed in the table with “.0” added to the digit number. For example, Pn001.0 (i.e., digit No. 0 of parameter No. Pn001).
- The default setting for parameters set using 5 digits are displayed in the table with the leftmost digits not shown if they are 0 (e.g., if the default setting is 00080, 80 is entered in the table).
- Do not set parameters or digit numbers shown as “Not used.”
- Parameters marked with one asterisk are for the DeviceNet Option Unit. Do not change the settings of these parameters unless a DeviceNet Option Unit is mounted.
- Parameters marked with two asterisks are supported by Servo Drivers with software version “r.0037.”

■ Function Selection Parameters (From Pn000)

Parameter No.	Parameter name	Digit No.	Name	Setting	Explanation	Default setting	Unit	Setting range	Restart power?
Pn000	Function selection basic switch	0	Reverse rotation	0	CCW direction is taken for positive command	0010	---	---	Yes
				1	CW direction is taken for positive command				
		1	Control mode selection	0	Speed control by analog command				
				1	Position control by pulse train command				
				2	Torque control by analog command				
				3	Internally set speed control				
				4	Switches between internally set speed control and speed control				
				5	Switches between internally set speed control and position control				
				6	Switches between internally set speed control and torque control				
				7	Switches between position control and speed control				
				8	Switches between position control and torque control				
				9	Switches between torque control and speed control				
				A	Speed control with position lock				
b	Position control with pulse prohibition								
2	Unit No. setting	0 to F	Servo Driver communications unit number setting (necessary for multiple Servo Driver connections when using personal computer monitoring software)						
3	Not used.	0	(Do not change setting.)						
Pn001	Function selection application switch 1	0	Select stop if an alarm occurs when Servomotor is OFF	0	Servomotor stopped by dynamic brake.	1002	---	---	Yes
				1	Dynamic brake OFF after Servomotor stopped				
				2	Servomotor stopped with free run				
		1	Select stop when prohibited drive is input	0	Stop according to Pn001.0 setting (release Servomotor after stopping)				
				1	Stop Servomotor using torque set in Pn406, and lock Servomotor after stopping				
				2	Stop Servomotor using torque set in Pn406, and release Servomotor after stopping				
		2	Select AC/DC power input	0	AC power supply: AC power supplied from L1, L2, (L3) terminals				
				1	DC power supply: DC power from +1, - terminals				
		3	Select warning code output	0	Alarm code only output from ALO1, ALO2, ALO3				
				1	Alarm code and warning code output from ALO1, ALO2, ALO3				

Parameter No.	Parameter name	Digit No.	Name	Setting	Explanation	Default setting	Unit	Setting range	Restart power?
Pn002	Function selection application switch 2	0	Torque command input change (during position and speed control)	0	Not used.	0000	---	---	Yes
				1	Use TREF as analog torque limit input				
				2	Use TREF as torque feed forward input				
				3	Use TREF as analog torque limit when PCL and NCL are ON				
		1	Speed command input change (during torque control)	0	Not used.				
				1	Use REF as analog speed limit input				
		2	Operation switch when using absolute encoder	0	Use as absolute encoder				
				1	Use as incremental encoder				
		3	Fully-closed encoder usage method*	0	Fully-closed encoder is not used.	0000	---	---	Yes
				1	Fully-closed encoder is used without phase Z.				
				2	Fully-closed encoder is used with phase Z.				
				3	Fully-closed encoder is used in Reverse Rotation Mode without phase Z.				
				4	Fully-closed encoder is used in Reverse Rotation Mode with phase Z.				
		Pn003	Function selection application switch 3	0	Analog monitor 1 (AM) allocation	0	Servomotor rotation speed: 1V/1000 r/min	0002	---
1	Speed command: 1 V/1000 r/min								
2	Torque command: 1 V/rated torque								
3	Position deviation: 0.05 V/1 command unit								
4	Position deviation: 0.05 V/100 command units								
5	Command pulse frequency: 1 V/1000 r/min.								
6	Servomotor rotation speed: 1 V/250 r/min								
7	Servomotor rotation speed: 1 V/125 r/min								
8 to F	Not used.								
1	Analog monitor 2 (NM) allocation			0 to F	Same as Pn003.0				
2 to 3	Not used.	0	(Do not change setting.)						
Pn004	Not used.	---		---	(Do not change setting.)	0000	---	---	---
Pn005	Not used.	---		---	(Do not change setting.)	0000	---	---	---

■ Servo Gain Parameters (From Pn100)

Parameter No.	Parameter name	Explanation (See note 1.)				Default setting	Unit	Setting range	Restart power?
		Digit No.	Name	Setting	Explanation (See note 2.)				
Pn100	Speed loop gain	Adjusts speed loop responsiveness.				80	Hz	1 to 2000	---
Pn101	Speed loop integration constant	Speed loop integral time constant				2000	x 0.01 ms	15 to 51200	---
Pn102	Position loop gain	Adjusts position loop responsiveness.				40	1/s	1 to 2000	---
Pn103	Inertia ratio	Set using the ratio between the machine system inertia and the Servomotor rotor inertia.				300	%	0 to 20000 (See note 3.)	---
Pn104	Speed loop gain 2	Adjusts speed loop responsiveness (enabled by gain switching input).				80	Hz	1 to 2000	---
Pn105	Speed loop integration constant 2	Speed loop integral time constant (enabled by gain switching input).				2000	x 0.01 ms	15 to 51200	---
Pn106	Position loop gain 2	Adjusts position loop responsiveness (enabled by gain switching input).				40	1/s	1 to 2000	---
Pn107	Bias rotational speed	Sets position control bias.				0	r/min	0 to 450	---
Pn108	Bias addition band	Sets the position control bias operation start using deviation counter pulse width.				7	Command unit	0 to 250	---
Pn109	Feed-forward amount	Position control feed-forward compensation value				0	%	0 to 100	---
Pn10A	Feed-forward command filter	Sets position control feed-forward command filter.				0	x 0.01 ms	0 to 6400	---
Pn10b	Speed control setting	0	P control switching conditions	0	Sets internal torque command value conditions (Pn10C).	004	---	---	Yes
				1	Sets speed command value conditions (Pn10d).				
				2	Sets acceleration command value conditions (Pn10E)				
				3	Sets deviation pulse value conditions (Pn10F)				
				4	No P control switching function				
		1	Speed control loop switching	0	PI control				
				1	IP control				
		2	Automatic gain switching selection **	0	Automatic gain switching disabled				
				1	Gain switching using position commands				
				2	Gain switching using position deviation				
		3	Not used.	0	(Do not change setting.)				

Parameter No.	Parameter name	Explanation (See note 1.)				Default setting	Unit	Setting range	Restart power?
		Digit No.	Name	Setting	Explanation (See note 2.)				
Pn10C	P control switching (torque command)	Sets level of torque command to switch from PI control to P control.				200	%	0 to 800	---
Pn10d	P control switching (speed command)	Sets level of speed command to switch from PI control to P control.				0	r/min	0 to 10000	---
Pn10E	P control switching (acceleration command)	Sets level of acceleration command to switch from PI control to P control.				0	10 r/min/s	0 to 3000	---
Pn10F	P control switching (deviation pulse)	Sets level of deviation pulses to switch from PI control to P control.				10	Command unit	0 to 10000	---
Pn110	Online autotuning setting	0	Selects online auto-tuning	0	Auto-tunes initial operations only after power is turned ON.	0012	---	---	Yes
				1	Always auto-tunes.				
				2	No auto-tuning				
		1	Selects speed feedback compensation function	0	ON				
				1	OFF				
		2	Selects adhesive friction compensation function	0	Friction compensation: OFF				
				1	Friction compensation: rated torque ratio small				
				2	Friction compensation: rated torque ratio large				
		3	Not used.	0	(Do not change setting.)				
		Pn111	Speed feedback compensating gain	Adjusts speed loop feedback gain.					
Pn112	Not used.	(Do not change setting.)				100	---	---	---
Pn113	Not used.	(Do not change setting.)				1000	---	---	---
Pn114	Not used.	(Do not change setting.)				200	---	---	---
Pn115	Not used.	(Do not change setting.)				32	---	---	---
Pn116	Not used.	(Do not change setting.)				16	---	---	---
Pn117	Not used.	(Do not change setting.)				100	---	---	---
Pn118	Not used.	(Do not change setting.)				100	---	---	---
Pn119	Not used.	(Do not change setting.)				50	---	---	---
Pn11A	Not used.	(Do not change setting.)				1000	---	---	---
Pn11b	Not used.	(Do not change setting.)				50	---	---	---
Pn11C	Not used.	(Do not change setting.)				70	---	---	---
Pn11d	Not used.	(Do not change setting.)				100	---	---	---
Pn11E	Not used.	(Do not change setting.)				100	---	---	---
Pn11F	Not used.	(Do not change setting.)				0	---	---	---
Pn120	Not used.	(Do not change setting.)				0	---	---	---
Pn121	Not used.	(Do not change setting.)				50	---	---	---
Pn122	Not used.	(Do not change setting.)				0	---	---	---
Pn123	Not used.	(Do not change setting.)				0	---	---	---

Parameter No.	Parameter name	Explanation (See note 1.)			Default setting	Unit	Setting range	Restart power?
		Digit No.	Name	Setting				
Pn124**	Automatic gain switching timer				100	ms	1 to 10000	---
Pn125**	Automatic gain switching width (amount of position deviation)				7	Command unit	1 to 250	---

Note 1. Explanation for parameters set using 5 digits.

Note 2. Explanation for parameters requiring each digit No. to be set separately.

Note 3. The setting range is 0 to 10,000 for Servo Drivers with a software version of “r.0014” or earlier.

■ Position Control Parameters (From Pn200)

Parameter No.	Parameter name	Explanation (See note 1.)				Default setting	Unit	Setting range	Restart power?
		Digit No.	Name	Setting	Explanation (See note 2.)				
Pn200	Position control setting 1	0	Command pulse mode	0	Feed pulse forward/reverse signal: Positive logic	1011	---	---	Yes
				1	Forward pulse/reverse pulse: Positive logic				
				2	90° phase difference (A/B phase) signal (x1): Positive logic				
				3	90° phase difference (A/B phase) signal (x2): Positive logic				
				4	90° phase difference (A/B phase) signal (x4): Positive logic				
				5	Feed pulses/Forward/reverse signal: Negative logic				
				6	Forward pulse/reverse pulse: Negative logic				
				7	90° phase difference (A/B phase) signal (x1): Negative logic				
				8	90° phase difference (A/B phase) signal (x2): Negative logic				
				9	90° phase difference (A/B phase) signal (x4): Negative logic				
		1	Deviation counter reset	0	High level signal				
				1	Rising signal (low to high)				
				2	Low level signal				
				3	Falling signal (low to high)				
		2	Deviation counter reset if an alarm occurs when the Servomotor is OFF	0	Deviation counter reset if an alarm occurs when Servomotor is OFF.				
				1	Deviation counter not reset if an alarm occurs when Servomotor is OFF.				
				2	Deviation counter reset only if alarm occurs.				
		3	Pulse command filter selection	0	Command filter for line driver signal input (500 kpps)				
				1	Command filter for open-collector signal input (200 kpps)				
Pn201	Encoder divider rate	Sets the number of output pulses from the Servo Driver.			1000	pulse/rotation	16 to 16384	Yes	
Pn202	Electronic gear ratio G1 (numerator)	Sets the pulse rate for the command pulses and Servo Servomotor travel distance. $0.01 \leq G1/G2 \leq 100$			4	---	1 to 65535	Yes	
Pn203	Electronic gear ratio G2 (denominator)				1	---	1 to 65535	Yes	
Pn204	Position command filter time constant 1 (primary filter)	Sets soft start for command pulse. (Soft start characteristics are for the primary filter.)			0	x 0.01 ms	0 to 6400	---	

Parameter No.	Parameter name	Explanation (See note 1.)				Default setting	Unit	Setting range	Restart power?
		Digit No.	Name	Setting	Explanation (See note 2.)				
Pn205	Absolute encoder multi-turn limit setting	Sets the limit to the number of rotations when using a Servo Servomotor with an absolute encoder.				65535	rotations	0 to 65535	Yes
Pn206 *	Number of fully-closed encoder pulses	Sets the number of fully-closed encoder pulses for each motor rotation.				16384	pulses/rotation	25 to 65535	Yes
Pn207	Position control setting 2	0	Selects position command filter.	0	Primary filter (Pn204)	0000	---	---	Yes
				1	Linear acceleration and deceleration (Pn208)				
		1	Speed command input switching (during position control)	0	Function not used				
				1	REF used as feed-forward input				
		2 to 3	Not used.	0	(Do not change setting.)				
Pn208	Position command filter time constant 2 (linear acceleration and deceleration)	Sets soft start for command pulse. (Soft start characteristics are for the linear acceleration and deceleration.)				0	x 0.01 ms	0 to 6400	---
Pn212 **	Not used.	(Do not change setting.)				2048	---	---	---
Pn217 **	Command pulse factor	Sets the factor used for position command pulse input.				1	Factor	1 to 99	---
Pn218 **	Position control setting 3	0	Command pulse factor switching selection	0	Disables the function.	0000	---	---	Yes
				1	Rotates the Servomotor using the command pulse multiplied by the factor set in Pn217.				
		1 to 3	Not used.	0	(Do not change setting.)				

Note 1. Explanation for parameters set using 5 digits.

Note 2. Explanation for parameters requiring each digit No. to be set separately.

■ Speed Control Parameters (From Pn300)

Parameter No.	Parameter name	Explanation	Default setting	Unit	Setting range	Restart power?
Pn300	Speed command scale	Sets the speed command voltage (REF)	1000	0.01 v/No. rated rotations	150 to 3000	---
Pn301	No. 1 internal speed setting	Number of rotations for No. 1 internal setting	100	r/min	0 to 10000	---
Pn302	No. 2 internal speed setting	Number of rotations for No. 2 internal setting	200	r/min	0 to 10000	---
Pn303	No. 3 internal speed setting	Number of rotations for No. 3 internal setting	300	r/min	0 to 10000	---
Pn304	Jog speed	Sets rotation speed during jog operation.	500	r/min	0 to 10000	---
Pn305	Soft start acceleration time	Sets acceleration time during speed control soft start.	0	ms	0 to 10000	---
Pn306	Soft start deceleration time	Sets deceleration time during speed control soft start.	0	ms	0 to 10000	---
Pn307	Speed command filter time constant	Sets constant during filter of speed command voltage input (REF).	40	x 0.01 ms	0 to 65535	---
Pn308	Speed feedback filter time constant	Sets constant during filter of speed feedback.	0	x 0.01 ms	0 to 65535	---
Pn309**	Not used.	(Do not change setting.)	60	---	---	---

■ Torque Control Parameters (From Pn400)

Parameter No.	Parameter name	Explanation (See note 1.)				Default setting	Unit	Setting range	Restart power?		
		Digit No.	Name	Setting	Explanation (See note 2.)						
Pn400	Torque command scale	Sets the torque command voltage (TREF) to output the rated torque.				30	0.1 V/ rated torque	10 to 100	---		
Pn401	Torque command filter time constant	Sets the constant when filtering the internal torque command.				40	x 0.01 ms	0 to 65535	---		
Pn402	Forward torque limit	Forward rotation output torque limit (rated torque ratio).				350	%	0 to 800	---		
Pn403	Reverse torque limit	Reverse rotation output torque limit (rated torque ratio).				350	%	0 to 800	---		
Pn404	Forward rotation external current limit	Output torque limit during input of forward rotation current limit (rated torque ratio)				100	%	0 to 800	---		
Pn405	Reverse rotation external current limit	Output torque limit during input of reverse rotation current limit (rated torque ratio)				100	%	0 to 800	---		
Pn406	Emergency stop torque	Deceleration torque when an error occurs (rated torque ratio)				350	%	0 to 800	---		
Pn407	Speed limit	Sets the speed limit in torque control mode.				3000	r/min	0 to 10000	---		
Pn408	Torque command setting	0	Selects notch filter 1.	0	Notch filter 1 not used.	0000	---	---	---		
				1	Notch filter 1 used for torque commands.						
		1	Not used.	0	(Do not change setting.)						
				2	Selects notch filter 2. **					0	Notch filter 2 not used.
										1	Notch filter 2 used for torque commands.
3	Not used.	0	(Do not change setting.)								
Pn409	Notch filter 1 frequency	Sets notch filter 1 frequency for torque command.				2000	Hz	50 to 2000	---		
Pn40A **	Notch filter 1 Q value	Sets Q value of notch filter 1.				70	x 0.01	50 to 400	---		
Pn40b **	Notch filter 2 frequency	Sets notch filter 2 frequency for torque command.				2000	hz	50 to 2000	---		
Pn40C **	Notch filter 2 Q value	Sets Q value of notch filter 2.				70	x 0.01	50 to 400	---		

Note 1. Explanation for parameters set using 5 digits.

Note 2. Explanation for parameters requiring each digit No. to be set separately.

■ Sequence Parameters (From Pn500)

Parameter No.	Parameter name	Explanation				Default setting	Unit	Setting range	Restart power?
		Digit No.	Name	Setting	Explanation				
Pn500	Positioning completion range 1	Sets the range of positioning completed output 1 (INP1).				3	Command unit	0 to 250	---
Pn501	Position lock rotation speed	Sets the number of rotations for position lock during speed control.				10	r/min	0 to 10000	---
Pn502	Rotation speed for motor rotation detection	Sets the number of rotations for the Servomotor rotation detection output (TGON).				20	r/min	1 to 10000	---
Pn503	Speed conformity signal output width	Sets the allowable fluctuation (number of rotations) for the speed conformity output (VCMP).				10	r/min	0 to 100	---
Pn504	Positioning completion range 2	Sets the range for positioning completed output 2 (INP2).				3	Command unit	1 to 250	---
Pn505	Deviation counter overflow level	Sets the detection level for the deviation counter over alarm.				1024	x 256 command unit	1 to 32767	---
Pn506	Brake timing 1	Sets the delay from the brake command to the Servomotor turning OFF.				0	x 10 ms	0 to 50	---
Pn507	Brake command speed	Sets the number of rotations for outputting the brake command.				100	r/min	0 to 10000	---
Pn508	Brake timing 2	Sets the delay time from the Servomotor turning OFF to the brake command output.				50	x 10 ms	10 to 100	---
Pn509	Momentary hold time	Sets the time during which alarm detection is disabled when a power failure occurs.				20	ms	20 to 1000	---

Parameter No.	Parameter name	Explanation				Default setting	Unit	Setting range	Restart power?
		Digit No.	Name	Setting	Explanation				
Pn50A	Input signal selection 1	0	Input signal allocation mode	0	Sets the sequence input signal allocation to the same as R88D-UT.	8100	---	---	Yes
				1	User-defined sequence input signal allocation				
		1	RUN signal (RUN command) input terminal allocation	0	Allocated to CN1, pin 40: Valid at low input.				
				1	Allocated to CN1, pin 41: Valid at low input				
				2	Allocated to CN1, pin 42: Valid at low input				
				3	Allocated to CN1, pin 43: Valid at low input				
				4	Allocated to CN1, pin 44: Valid at low input				
				5	Allocated to CN1, pin 45: Valid at low input				
				6	Allocated to CN1, pin 46: Valid at low input				
				7	Always enabled.				
				8	Always disabled.				
				9	Allocated to CN1, pin 40: Valid at high output				
				A	Allocated to CN1, pin 41: Valid at high output				
				b	Allocated to CN1, pin 42: Valid at high output				
				C	Allocated to CN1, pin 43: Valid at high output				
				d	Allocated to CN1, pin 44: Valid at high output				
E	Allocated to CN1, pin 45: Valid at high output								
F	Allocated to CN1, pin 46: Valid at high output								
2	MING signal input terminal allocation	0 to F	Same as Pn50A.1. MING (gain reduction) signal allocation						
3	POT signal Input terminal allocation	0 to F	Same as Pn50A.1 POT (forward drive prohibited) signal allocation						

Parameter No.	Parameter name	Explanation				Default setting	Unit	Setting range	Restart power?
		Digit No.	Name	Setting	Explanation				
Pn50b	Input signal selection 2	0	NOT signal Input terminal allocation	0 to F	Same as Pn50A.1. NOT (reverse drive prohibited) signal allocation	6548	---	---	Yes
		1	RESET signal Input terminal allocation	0 to F	Same as Pn50A.1. RESET (alarm reset) signal allocation				
		2	PCL signal Input terminal allocation	0 to F	Same as Pn50A.1. PCL (forward rotation current limit) signal allocation				
		3	NCL signal Input terminal allocation	0 to F	Same as Pn50A.1. NCL (reverse rotation current limit) allocation				
Pn50C	Input signal selection 3	0	RDIR signal Input terminal allocation	0 to F	Same as Pn50A.1. RDIR (rotation direction command) signal allocation	8888	---	---	Yes
		1	SPD1 signal Input terminal allocation	0 to F	Same as Pn50A.1. SPD1 (speed selection reference 1) signal allocation				
		2	SPD2 signal Input terminal allocation	0 to F	Same as Pn50A.1. SPD2 (speed selection command 2) signal allocation				
		3	TVSEL signal Input terminal allocation	0 to F	Same as Pn50A.1. TVSEL (control mode switching) signal allocation				
Pn50d	Input signal selection 4	0	PLOCK signal Input terminal allocation	0 to F	Same as Pn50A.1. PLOCK (position lock command) signal allocation	8888	---	---	Yes
		1	IPG signal Input terminal allocation	0 to F	Same as Pn50A.1. IPG (pulse disable) signal allocation				
		2	GSEL signal Input terminal allocation	0 to F	Same as Pn50A.1. GSEL (gain switching) signal allocation				
		3	Not used.	8	(Do not change setting.)				

Parameter No.	Parameter name	Explanation				Default setting	Unit	Setting range	Restart power?		
		Digit No.	Name	Setting	Explanation						
Pn50E	Output signal selection 1	0	INP1 signal (positioning completed 1) output terminal allocation	0	No output	3211	---	---	Yes		
				1	Allocated to CN1 pins 25, 26						
				2	Allocated to CN1 pins 27, 28						
				3	Allocated to CN1 pins 29, 30						
		1	VCMP signal output terminal allocation	0 to 3	Same as Pn50E.0. VCMP (speed coincidence) signal allocation						
		2	TGON signal output terminal allocation	0 to 3	Same as Pn50E.0. TGON (Servomotor rotation detection) signal allocation						
3	READY signal output terminal allocation	0 to 3	Same as Pn50E.0. READY (Servomotor warmup complete) signal allocation								
Pn50F	Output signal selection 2	0	CLIMIT signal output terminal allocation	0 to 3	Same as Pn50E.0. CLIMIT (current limit detection) signal allocation	0000	---	---	Yes		
				1	VLIMIT signal output terminal allocation					0 to 3	Same as Pn50E.0. VLIMIT (speed limit detection) signal allocation
				2	BKIR signal output terminal allocation					0 to 3	Same as Pn50E.0. BKIR (brake interlock) signal allocation.
				3	WARN signal output terminal allocation					0 to 3	Same as Pn50E.0. WARN (warning) signal allocation
Pn510	Output signal selection 3	0	INP2 signal output terminal allocation	0 to 3	Same as Pn50E.0. INP2 (positioning completed 2) signal allocation	0000	---	---	Yes		
				1	Not used.					0	(Do not change setting.)
				2	PSON signal output terminal allocation**					0 to 3	Same as Pn50E.0. PSON (command pulse factor enabled) signal allocation
				3	Not used.					0	(Do not change setting.)
Pn511	Not used.	0 to 3	Not used.	8	(Do not change setting.)	8888	---	---	---		

Parameter No.	Parameter name	Explanation				Default setting	Unit	Setting range	Restart power?
		Digit No.	Name	Setting	Explanation				
Pn512	Output signal reverse	0	Output signal reverse for CN1 pins 25, 26	0	Not reversed.	0000	---	---	Yes
				1	Reversed.				
		1	Output signal reverse for CN1 pins 27, 28	0	Not reversed.				
				1	Reversed.				
		2	Output signal reverse CN1 pins 29, 30	0	Not reversed.				
				1	Reversed.				
3	Not used.	0	(Do not change setting.)						
Pn513 **	Input signal selection 6	0	PSEL signal input terminal allocation	0 to F	Same as Pn50A.1. PSEL (command pulse factor switching) signal allocation	0088	---	---	Yes
		1	Not used.	8	(Do not change setting.)				
		2 to 3	Not used.	0	(Do not change setting.)				
Pn51A *	Motor-load deviation over level	Sets the allowable range for the number of pulses for fully-closed encoders and semi-closed encoders.				0	Command unit	0 to 32767	---
Pn51b **	Not used.	(Do not change setting.)				100	---	---	---
Pn51C **	Not used.	(Do not change setting.)				450	---	---	---
Pn51E **	Deviation counter overflow warning level	Sets the detection level for the deviation counter overflow warning. (Set as a percentage for the deviation counter overflow level (Pn505).)				0	%	0 to 100	---

■ Other Parameters (From Pn600)

Parameter No.	Parameter name	Explanation	Default setting	Unit	Setting range	Restart power?
Pn600	Regeneration resistor capacity	Setting for regeneration resistance load ratio monitoring calculations	0	x 10 W	From 0 (varies by Unit.)	---
Pn601	Not used.	(Do not change setting.)	0	---	---	---

4-4-3 Important Parameters

This section explains the user parameters you need to set and check before using the Servomotor and Servo Driver. If these parameters are set incorrectly, there is a risk of the Servomotor not rotating, and of a misoperation. Set the parameters to suit your system.

■ Reverse Rotation Mode Settings (Pn000.0)

Pn000.0	Function selection basic switch — Reverse rotation mode (All operation modes)						
Setting range	0, 1	Unit	---	Default setting	0	Restart power?	Yes

Setting Explanation

Setting	Explanation
0	CCW direction is taken for positive command (counterclockwise seen from the Servomotor output shaft)
1	CW direction is taken for positive command (clockwise seen from the Servomotor output shaft)

- This parameter sets the Servomotor’s direction of rotation.
- Even if 1 is set, the Servo Driver’s encoder output phase (A/B phase) does not change (i.e., the Servomotor’s direction of rotation is simply reversed).
- For example, with a pulse command, the motor will rotate counterclockwise for a counterclockwise command if the Reverse Rotation Mode Setting is set to 0 and will rotate clockwise for a counterclockwise command if the Reverse Rotation Mode Setting is set to 1.

■ Control Mode Selection (Pn000.1)

Pn000.1	Function selection basic switch — Control mode selection (All operation modes)						
Setting range	0 to b	Unit	---	Default setting	1	Restart power?	Yes

Setting Explanation

Setting	Explanation
0	Speed control (Analog command)
1	Position control (Pulse train command)
2	Torque control (Analog command)
3	Internal speed control settings
4	Internal speed control settings ←→ Speed control (Analog command)
5	Internal speed control settings ←→ Position control (Pulse train command)
6	Internal speed control settings ←→ Torque control (Analog command)
7	Position control (Pulse train command) ←→ Speed control (Analog command)
8	Position control (Pulse train command) ←→ Torque control (Analog command)
9	Speed control (Analog command) ←→ Torque control (Analog command)
A	Speed control with position-lock function (Analog command)
b	Position control with pulse disable function (Pulse train command)

- Set to match the application content and the output form of the Host controller you are using.
- If using switching control mode (7 to 9), switch the control mode using TVSEL (control mode switch input).
- If using internal speed control setting and another control mode (4 to 6), switch control mode using SPD1 and SPD2 (speed selection command inputs 1 and 2).

■ Alarm Stop Selection (Pn001.0)

Pn001.0	Function selection application switch 1 — Stop selection for alarm generation with servo OFF (All operation modes)						
Setting range	0 to 2	Unit	---	Default setting	2	Restart power?	Yes

Setting Explanation

Setting	Explanation
0	Stop Servomotor using dynamic brake (dynamic brake stays ON after Servomotor has stopped).
1	Stop Servomotor using dynamic brake (dynamic brake released after Servomotor has stopped).
2	Stop Servomotor using free run.

- Select the stopping process for when the servo is turned OFF or an alarm occurs.
- **Dynamic Brake Operation when Power Is Turned OFF**
 The dynamic brake will remain ON if the main circuit and control circuit power supplies are turned OFF for Servo Drivers of the capacities listed below. This means that it will be slightly more difficult to turn the motor shaft by hand than it is when the dynamic brake is OFF. To release the dynamic brake, disconnect the Servo Motor wiring (U, V, or W). Always confirm that any disconnected wires are connected properly before turning ON the power supplies again.
 100-V AC input, 30 to 200 W: R88D-WTA3HL to R88D-WT02HL
 200-V AC input, 30 W to 1.5 kW: R88D-WTA3H to R88D-WT15H
- **Relationship between Main Circuit and Control Circuit Power Supply Status and Dynamic Brake Operation**
 R88D-WTA3HL to R88D-WT02HL (100-V AC input)
 R88D-WTA3H to R88D-WT15H (200-V AC input)

Power supply status		Dynamic brake operation		
Main circuit power supply	Control circuit power supply	PN001.0 = 0	PN001.0 = 1	PN001.0 = 2
ON	ON	ON	ON (then to OFF)	OFF
OFF	ON	ON	ON	ON
ON	OFF	ON	ON	ON
OFF	OFF	ON	ON	ON

R88D-WT20H to R88D-WT150H

Power supply status		Dynamic brake operation		
Main circuit power supply	Control circuit power supply	PN001.0 = 0	PN001.0 = 1	PN001.0 = 2
ON	ON	ON	ON (then to OFF)	OFF
OFF	ON	ON	ON (then to OFF)	OFF
ON	OFF	OFF	OFF	OFF
OFF	OFF	OFF	OFF	OFF

■ **Overtravel Stop Selection (Pn001.1)**

Pn001.1	Function selection application switch 1 — Stop selection for drive prohibition input (Position, speed, internally-set speed control)						
Setting range	0 to 2	Unit	---	Default setting	0	Restart power?	Yes

Setting Explanation

Setting	Explanation
0	Stop according to the setting of Pn001.0 (servo released after Servomotor has stopped)
1	Stop the Servomotor using the torque set in Pn406 (emergency stop torque), then locks the servo.
2	Stop the Servomotor using the torque set in Pn406 (emergency stop torque), then releases the servo (dynamic brake is turned OFF).

- Select the stopping process for when overtravel occurs.

Stopping Methods when Forward/Reverse Drive Prohibit is OFF

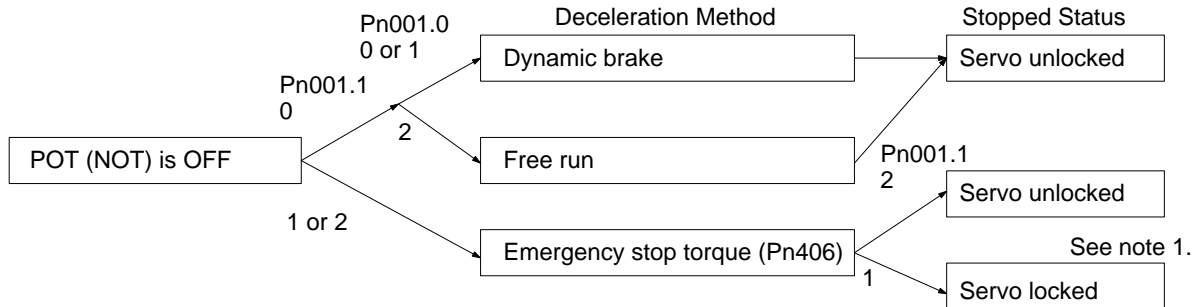

- Note 1.** The position loop is disabled when the servo stops in servolock mode during position control.
- Note 2.** During torque control, the stopping process depends on Pn001.0 (the Pn001.1 setting does not matter).
- Note 3.** POT and NOT are allocated to pin CN1-42 at the factory, and set to always OFF (i.e., drive prohibition is disabled). To use the drive prohibition function, change the setting using Pn50A.3 and Pn50b.0.
- Note 4.** With a vertical load, the load may fall due to its own weight if it is left at a drive prohibit input. We recommend that you set the stop method for the drive prohibit input (Pn001.1) for decelerating with the emergency stop torque, and then set stopping with the servo locked (SV: 1) to prevent the load from falling.

■ Command Pulse Mode Selection (Pn200.0): Position Control

Pn200.0	Position control setting 1 — Command Pulse Mode (Position)						
Setting range	0 to 9	Unit	---	Default setting	1	Restart power?	Yes

Setting Explanation

Setting	Explanation
0	Feed pulse/forward signal: Positive logic
1	Reverse pulse/reverse pulse: Positive logic
2	90° phase difference (A/B phase) signal (x1): Positive logic
3	90° phase difference (A/B phase) signal (x2): Positive logic
4	90° phase difference (A/B phase) signal (x4): Positive logic
5	Feed pulses/Forward/reverse signal: Negative logic
6	Forward pulse/reverse pulse: Negative logic
7	90° phase difference (A/B phase) signal (x1): Negative logic
8	90° phase difference (A/B phase) signal (x2): Negative logic
9	90° phase difference (A/B phase) signal (x4): Negative logic

- If using position control, select the command pulse mode to suit the Host Controller’s command pulse format.
- If inputting 90° phase difference signals, select either x1, x2, or x4. If you select x4, the input pulse will be multiplied by 4, so the number of Servomotor rotations (speed and angle) will be four times that of the x1 selection.

■ I/O Signal Allocation (Pn50A to Pn513)

- With the OMNUC W series, you can freely change the I/O signal allocation.
- If using an OMRON position controller (Position Control Unit or Motion Control Unit), you do not need to change the default settings. The various special Control Cables are also based on the default allocations.
- The default allocations (which are the same as for the R88D-UT OMRON Servo Driver) are as follows:

	CN1, pin No.	Signal name	Condition
Input signal	40	RUN (RUN command input)	---

	CN1, pin No.	Signal name	Condition
Input signal	41	MING (gain reduction input)	When Pn000.1 is 0 (speed control) or 1 (position control) When Pn000.1 is 3, 4, or 5 (internal speed control setting), and SPD1 and SPD2 are both OFF
		RDIR (rotation direction command input)	When Pn000.1 is 3, 4, 5, or 6 (internal speed control setting), and either SPD1 or SPD2 is ON
		TVSEL (control mode switch input)	When Pn000.1 is 7, 8, or 9 (switching control mode)
		PLOCK (position lock command input)	When Pn000.1 is A (speed command with position lock)
		IPG (pulse disable input)	When Pn000.1 is b (position control with pulse disable)
	42	POT (forward drive prohibit input)	Set to always OFF (i.e., drive prohibition is disabled).
	43	NOT (reverse drive prohibit input)	Set to always OFF (i.e., drive prohibition is disabled).
	44	RESET (alarm reset input)	---
	45	PCL (forward rotation current limit input)	When Pn000.1 is 0 to 2, or 7, 8, 9, A, or b.
		SPD1 (speed selection command 1 input)	When Pn000.1 is 3, 4, 5, or 6 (internal speed control setting).
46	NCL (reverse rotation current limit input)	When Pn000.1 is 0, 1, or 2, or 7, 8, 9, A, or b.	
	SPD2 (speed selection command 2 input)	When Pn000.1 is 3, 4, 5, or 6 (internal speed control setting).	
Output signal	25/26	INP1 (Positioning completed output 1)	When using Position Control Mode.
		VCMP (speed conformity output)	When using Speed Control Mode or Internally-set Speed Control Mode.
	27/28	TGON (Servomotor rotation detection output)	---
	29/30	READY (Servo ready output)	---

● Input Signal Selection (Pn50A to Pn50d, Pn513)

Pn50A.0	Input signal selection 1 — Input signal allocation mode (All operation modes)						
Setting range	0, 1	Unit	---	Default setting	0	Restart power?	Yes

Setting Explanation

Setting	Explanation
0	Sets the sequence input signal allocation to the same as R88D-UT
1	User-defined sequence input signal allocation

- If set to 0, the input signal allocation for CN1 is the same as shown above. You cannot change the input signal pin number with this setting. You can, however, select whether the signal is always ON or always OFF, using Pn50A.1 to Pn50b.3.
- If set to 1, you can set the input signal pin number (Pn50A.1 to Pn50d.2). You can also allocate multiple input signals to one pin number, in which case, when a signal is input, all signals allocated to that pin number are input. For example, if switching between speed control and position control, when the gain is lowered using speed control, if both TVSEL (control mode switch input) and MING (gain reduction input) are allocated to the same pin number, switching to speed control and gain reduction will be performed as one signal.

Pn50A.1	Input signal selection 1 — RUN signal (RUN command) input terminal allocation (All operation modes)						
Setting range	0 to F	Unit	---	Default setting	0	Restart power?	Yes

Setting Explanation

Setting	Explanation
0	Allocated to CN1-40 pin: enabled using L input
1	Allocated to CN1-41 pin: enabled using L input
2	Allocated to CN1-42 pin: enabled using L input
3	Allocated to CN1-43 pin: enabled using L input
4	Allocated to CN1-44 pin: enabled using L input
5	Allocated to CN1-45 pin: enabled using L input
6	Allocated to CN1-46 pin: enabled using L input
7	Always ON
8	Always OFF
9	Allocated to CN1-40 pin: enabled using H input
A	Allocated to CN1-41 pin: enabled using H input
b	Allocated to CN1-42 pin: enabled using H input
C	Allocated to CN1-43 pin: enabled using H input
d	Allocated to CN1-44 pin: enabled using H input
E	Allocated to CN1-45 pin: enabled using H input
F	Allocated to CN1-46 pin: enabled using H input

- If Pn50A.0 is set to 0, you cannot change the pin number. Settings 0 to 6 and 9 to F are disabled, and all are set to CN1, pin 40 enabled by L input. Settings 7 and 8 are both enabled.
- To change the pin number, set Pn50A.0 to 1.

- When set to 7, the servo turns ON after the power has been turned ON. You cannot use the jog operation with this setting.

Pn50A.2	Input signal selection 1 — MING signal (gain reduction) input terminal allocation (Position, speed, internally-set speed control)						
Setting range	0 to F	Unit	---	Default setting	1	Restart power?	Yes

- Settings are the same as for Pn50A.1.
- If Pn50A.0 is set to 0, you cannot change the pin number. Settings 0 to 6 and 9 to F are disabled, and all are set to CN1, pin 41 enabled by L input. Settings 7 and 8 are both enabled.
- To change the pin number, set Pn50A.0 to 1.

Pn50A.3	Input signal selection 1 — POT signal (forward drive prohibited) input terminal allocation (All operation modes)						
Setting range	0 to F	Unit	---	Default setting	8	Restart power?	Yes

- Settings are the same as for Pn50A.1.
- If Pn50A.0 is set to 0, you cannot change the pin number. Settings 0 to 6 and 9 to F are disabled, and all are set to CN1, pin 42 enabled by L input. Settings 7 and 8 are both enabled.
- To change the pin number, set Pn50A.0 to 1.
- If set to 7 (always ON), the servo is in always overtravel status (i.e., forward rotation is always drive-prohibited).
- If set to 8 (always OFF), the servo drive prohibition is OFF (i.e., the forward rotation drive is permitted).
- The POT signal permits forward rotation drive upon input.

Pn50b.0	Input signal selection 2 — NOT signal (reverse drive prohibited) input terminal allocation (All operation modes)						
Setting range	0 to F	Unit	---	Default setting	8	Restart power?	Yes

- Settings are the same as for Pn50A.1.
- If Pn50A.0 is set to 0, you cannot change the pin number. Settings 0 to 6 and 9 to F are disabled, and all are set to CN1, pin 43 enabled by L input. Settings 7 and 8 are both enabled.
- To change the pin number, set Pn50A.0 to 1.
- If set to 7 (always ON), the servo is in always in overtravel status (i.e., reverse rotation is always drive-prohibited).
- If set to 8 (always OFF), the servo drive prohibition is OFF (i.e., the reverse rotation drive is permitted).
- The NOT signal permits reverse rotation drive upon input.

Pn50b.1	Input signal selection 2 — RESET signal (alarm reset) input terminal allocation (All operation modes)						
Setting range	0 to F	Unit	---	Default setting	4	Restart power?	Yes

- Settings are the same as for Pn50A.1.
- If Pn50A.0 is set to 0, you cannot change the pin number. Settings 0 to 6 and 9 to F are disabled, and all are set to CN1, pin 44 enabled by L input. Settings 7 and 8 are both enabled.
- To change the pin number, set Pn50A.0 to 1.

- Do not set 7 (always ON).
- If setting 8 (always OFF), when the alarm is cancelled, turn ON the power or reset the alarm using the operation keys.

Pn50b.2	Input signal selection 2 — PCL signal (forward rotation current limit) input terminal allocation (All operation modes)						
Setting range	0 to F	Unit	---	Default setting	5	Restart power?	Yes

- Settings are the same as for Pn50A.1.
- If Pn50A.0 is set to 0, you cannot change the pin number. Settings 0 to 6 and 9 to F are disabled, and all are set to CN1, pin 45 enabled by L input. Settings 7 and 8 are both enabled.
- To change the pin number, set Pn50A.0 to 1.

Pn50b.3	Input signal selection 2 — NCL signal (reverse rotation current limit) input terminal allocation (All operation modes)						
Setting range	0 to F	Unit	---	Default setting	6	Restart power?	Yes

- Settings are the same as for Pn50A.1.
- If Pn50A.0 is set to 0, you cannot change the pin number. Settings 0 to 6 and 9 to F are disabled, and all are set to CN1, pin 46 enabled by L input. Settings 7 and 8 are both enabled.
- To change the pin number, set Pn50A.0 to 1.

Pn50C.0	Input signal selection 3 — RDIR signal (rotation direction command) input terminal allocation (internally-set speed control)						
Setting range	0 to F	Unit	---	Default setting	8	Restart power?	Yes

- Settings are the same as for Pn50A.1.
- If Pn50A.0 is set to 0, you cannot change the pin number. Settings 0 to F are all disabled.
- To change the pin number, set Pn50A.0 to 1.

Pn50C.1	Input signal selection 3 — SPD1 signal (speed selection command 1) input terminal allocation (internally-set speed control)						
Setting range	0 to F	Unit	---	Default setting	8	Restart power?	Yes

- Settings are the same as for Pn50A.1.
- If Pn50A.0 is set to 0, you cannot change the pin number. Settings 0 to F are all disabled.
- To change the pin number, set Pn50A.0 to 1.

Pn50C.2	Input signal selection 3 — SPD2 signal (speed selection command 2) input terminal allocation (internally-set speed control)						
Setting range	0 to F	Unit	---	Default setting	8	Restart power?	Yes

- Settings are the same as for Pn50A.1.
- If Pn50A.0 is set to 0, you cannot change the pin number. Settings 0 to F are all disabled.
- To change the pin number, set Pn50A.0 to 1.

Pn50C.3	Input signal selection 3 — TVSEL signal (control mode switching) input terminal allocation (Switching control)						
Setting range	0 to F	Unit	---	Default setting	8	Restart power?	Yes

- Settings are the same as for Pn50A.1.
- If Pn50A.0 is set to 0, you cannot change the pin number. Settings 0 to F are all disabled.
- To change the pin number, set Pn50A.0 to 1.

Pn50d.0	Input signal selection 4 — PLOCK signal (position lock command) input terminal allocation (Speed)						
Setting range	0 to F	Unit	---	Default setting	8	Restart power?	Yes

- Settings are the same as for Pn50A.1.
- If Pn50A.0 is set to 0, you cannot change the pin number. Settings 0 to F are all disabled.
- To change the pin number, set Pn50A.0 to 1.

Pn50d.1	Input signal selection 4 — IPG signal (pulse disable) input terminal allocation (Position)						
Setting range	0 to F	Unit	---	Default setting	8	Restart power?	Yes

- Settings are the same as for Pn50A.1.
- If Pn50A.0 is set to 0, you cannot change the pin number. Settings 0 to F are all disabled.
- To change the pin number, set Pn50A.0 to 1.

Pn50d.2	Input signal selection 4 — GSEL signal (gain switching) input terminal allocation (Position, speed, internally-set speed control)						
Setting range	0 to F	Unit	---	Default setting	8	Restart power?	Yes

- Settings are the same as for Pn50A.1.
- If Pn50A.0 is set to 0, you cannot use GSEL signal. Settings 0 to F are all disabled.
- To use the GSEL signal, set Pn50A.0 to 1.

Pn513.0	Input signal selection 6 — PSEL signal (command pulse factor switching) input terminal allocation (Position)						
Setting range	0 to F	Unit	---	Default setting	8	Restart power?	Yes

- Settings are the same as for Pn50A.1.
- If Pn50A.0 is set to 0, you cannot change the pin number. Settings 0 to F are all disabled.
- To change the pin number, set Pn50A.0 to 1.
- This new parameter is supported by Servo Drivers with software version “r.0037.”

• Output Signal Selection (Pn50E to Pn510, Pn512)

- Output signal selection is performed in Pn50E to Pn510, and whether each signal should be reversed is set in Pn512.
- You can allocate multiple output signals to the same pin. Such signals are output separately as an OR operation.
- The default settings allocate INP1 (positioning completed output 1) and VCMP (speed conformity) to pin Nos. 25 and 26. In Position Control Mode, INP1 is output, and in Speed Control Mode, VCMP is output. Also, TGON (Servomotor rotation detection) is allocated to pins 27 and 28, and READY (Servomotor ready) is allocated to pins 29 and 30.

Pn50E.0	Output signal selection 1 — INP1 signal (positioning completed output 1) output terminal allocation (Position)						
Setting range	0 to 3	Unit	---	Default setting	1	Restart power?	Yes

Setting Explanation

Setting	Explanation
0	No output
1	Allocated to pins CN1-25 and 26 (pin 26 is the COM port)
2	Allocated to pins CN1-27 and 28 (pin 28 is the COM port)
3	Allocated to pins CN1-29 and 30 (pin 30 is the COM port)

Pn50E.1	Output signal selection 1 — VCMP signal (speed conformity) output terminal allocation (Speed)						
Setting range	0 to 3	Unit	---	Default setting	1	Restart power?	Yes

Pn50E.2	Output signal selection 1 — TGON signal (Servomotor rotation detection) output terminal allocation (All operation modes)						
Setting range	0 to 3	Unit	---	Default setting	2	Restart power?	Yes

Pn50E.3	Output signal selection 1 — READY signal (Servomotor ready) output terminal allocation (All operation modes)						
Setting range	0 to 3	Unit	---	Default setting	3	Restart power?	Yes

Pn50F.0	Output signal selection 2 — CLIMIT signal (current limit detection) output terminal allocation (All operation modes)						
Setting range	0 to 3	Unit	---	Default setting	0	Restart power?	Yes

Pn50F.1	Output signal selection 2 — VLIMIT signal (speed limit detection) output terminal allocation (Torque)						
Setting range	0 to 3	Unit	---	Default setting	0	Restart power?	Yes

Pn50F.2	Output signal selection 2 — BKIR signal (brake interlock) output terminal allocation (All operation modes)						
Setting range	0 to 3	Unit	---	Default setting	0	Restart power?	Yes

Pn50F.3	Output signal selection 2 — WARN signal (warning) output terminal allocation (All operation modes)						
Setting range	0 to 3	Unit	---	Default setting	0	Restart power?	Yes

Pn510.0	Output signal selection 3 — INP2 (positioning completed 2) output terminal allocation (Position)						
Setting range	0 to 3	Unit	---	Default setting	0	Restart power?	Yes

Pn510.2	Output signal selection 3 — PSON (command pulse factor enabled) output terminal allocation						
Setting range	0 to 3	Unit	---	Default setting	0	Restart power?	Yes

- Parameter settings are the same as for Pn50E.0.
- Pn510.2 is a new parameter supported by Servo Drivers with software version “r.0037.”

Pn512.0	Output signal reverse — Pins CN1-25 and 26 output signal reverse (All operation modes)						
Setting range	0, 1	Unit	---	Default setting	0	Restart power?	Yes

Setting Explanation

Setting	Explanation
0	Not reversed.
1	Reversed.

- Select the characteristics of the output signal allocated to pins CN1-25 and 26.
- If you set 1 (reverse), ON/OFF outputs are reversed.

Pn512.1	Output signal reverse — Pins CN1-27 and 28 output signal reverse (All operation modes)						
Setting range	0, 1	Unit	---	Default setting	0	Restart power?	Yes

Setting Explanation

Setting	Explanation
0	Not reversed.
1	Reversed.

Pn512.2	Output signal reverse — Pins CN1-29 and 30 output signal reverse (All operation modes)						
Setting range	0, 1	Unit	---	Default setting	0	Restart power?	Yes

Setting Explanation

Setting	Explanation
0	Not reversed.
1	Reversed.

4-4-4 Parameter Details

This section explains all user parameters not already explained in *4-4-3 Important Parameters*. Make sure you fully understand the meaning of each parameter before making any changes to parameter settings. Be sure not to change parameters designated “Not used.”, and digit No. settings.

■ **Function Selection Parameters (From Pn000)**

● **Function Selection Basic Switch (Pn000: Default Setting 0010)**

Pn000.0	Function selection basic switch — Reverse rotation mode (All operation modes)						
Setting range	0, 1	Unit	---	Default setting	0	Restart power?	Yes

Note Refer to *4-4-3 Important Parameters*.

Pn000.1	Function selection basic switch — Control mode selection (All operation modes)						
Setting range	0 to b	Unit	---	Default setting	1	Restart power?	Yes

Note Refer to 4-4-3 Important Parameters.

Pn000.2	Function selection basic switch — Unit No. setting (All operation modes)						
Setting range	0 to F	Unit	---	Default setting	0	Restart power?	Yes

Setting Explanation

Setting	Explanation
0 to F	Sets the Servo Driver unit number

- You must make settings if connecting multiple Servo Drivers using OMNUC W-series Servo Driver Computer Monitoring Software (for Windows95). Refer to the software for details.

Pn000.3	Function selection basic switch — Not used.						
Setting range	---	Unit	---	Default setting	0	Restart power?	Yes

Note Do not change setting.

• Function Selection Application Switch 1 (Pn001: Default setting 1002)

Pn001.0	Function selection application switch 1 — Stop selection if alarm occurs when servo is OFF (All operation modes)						
Setting range	0 to 2	Unit	---	Default setting	2	Restart power?	Yes

Note Refer to 4-4-3 Important Parameters.

Pn001.1	Function selection application switch 1 — Stop selection when drive prohibited is input (Position, speed, internally-set speed control)						
Setting range	0 to 2	Unit	---	Default setting	0	Restart power?	Yes

Note Refer to 4-4-3 Important Parameters.

Pn001.2	Function selection application switch 1 — AC/DC power supply input selection (All operation modes)						
Setting range	0, 1	Unit	---	Default setting	0	Restart power?	Yes

Setting Explanation

Setting	Explanation
0	AC power supply: AC power supplied from L1, L2, (L3) terminals
1	DC power supply: DC power from +1, – terminals

- Select setting 1 if using a DC power supply.
- If using a DC power supply, perform the following operations.
Control circuit power supply: Supply DC power to L1C and L2C. There is no polarity.

Main circuit power supply: Supply DC power as follows: positive voltage to +1 terminal, and ground to – terminal.

External regeneration resistance terminals: Remove the short bar from between B2 and B3 so that B1, B2, and B3 are open. (For Servo Drivers without B3, open B1 and B2.)

Make sure input voltage is 120 to 179 V DC for 100 V input type, and 240 to 357 V DC for 200 V input type.

- Note 1.** Always set this parameter to 1 when using a DC power supply. If a DC power supply is connected with this parameter set to 0, the regeneration absorption circuit will operate, possibly damaging the Servo Driver. When changing the setting from 0 to 1, either the main circuit power supply must be OFF, or the external regeneration resistance terminals must be open.
- Note 2.** If using a DC power supply, the regeneration absorption circuit inside the Servo Driver will not operate. The regeneration power returns to the DC power supply, so make sure the DC power supply can absorb the regeneration power.
- Note 3.** If using a DC power supply, the residual voltage in the main-circuit power supply is not discharged rapidly when the power is turned OFF. Be sure to mount a discharge circuit on the DC power supply. Also, check that the charge indicator is not lit before storing the power supply input when the power supply has been turned OFF (the discharge time for the Servo Driver is approximately 30 minutes.)

Pn001.3	Function selection application switch 1 — Warning code output selection (All operation modes)						
Setting range	0, 1	Unit	---	Default setting	1	Restart power?	Yes

Setting Explanation

Setting	Explanation
0	Only alarm code is output from ALO1, ALO2, and ALO3
1	Both alarm code and warning code are output from ALO1, ALO2, and ALO3

- Select whether the alarm code output will be from outputs ALO1 to ALO3 (CN1-37 to 39) if an alarm (overload alarm, regeneration overload alarm) occurs.

Note Refer to 5-2 Alarms for warning code details.

• Function Selection Application Switch 2 (Pn002: Default Setting 0000)

Pn002.0	Function selection application switch 2 — Torque command input change (Position, speed)						
Setting range	0 to 3	Unit	---	Default setting	0	Restart power?	Yes

Setting Explanation

Setting	Explanation
0	Function not used.
1	TREF used as analog torque limit.
2	TREF used as torque feed-forward input.
3	TREF used as analog torque limit when PCL and NCL are ON.

- Set TREF (torque command input) function when using position control and speed control.

- Set 1 to limit the output torque to the same value for both forward and reverse regardless of TREF voltage polarity (read as an absolute value).
- Set 2 to calculate torque corresponding to TREF voltage in the current loop (TREF voltage polarity enabled).
- Set 3 to limit the forward output torque during PCL input (forward current limit input), and limit the reverse output torque during NCL input (reverse current limit input), regardless of TREF voltage polarity (read as an absolute value).
- You can change the TREF voltage scale using Pn400 (torque command scale). Default setting: 3 V/rated torque.

Note Other torque limit functions include Pn402 (forward torque limit), Pn403 (reverse torque limit), Pn404 (Forward rotation external current limit), and Pn405 (Reverse rotation external current limit). The smallest output torque from among the enabled limitations is limited.

Pn002.1	Function selection application switch 2 — Speed command input switching (Torque)						
Setting range	0, 1	Unit	---	Default setting	0	Restart power?	Yes

Setting Explanation

Setting	Explanation
0	Function not used.
1	REF used as analog speed limit.

- Set the REF (speed command input) function for torque control.
- Set 1 to set REF voltage as the analog speed limit, regardless of polarity (read as an absolute value).
- You can change the REF voltage scale using Pn300 (speed command scale). Default setting: 10 V/rated rotation.

Note Other speed limitation functions include Pn407 (speed limit). The speed is limited to the lower value.

Pn002.2	Function selection application switch 2 — Operation switching using an absolute encoder (All operation modes, absolute)						
Setting range	0, 1	Unit	---	Default setting	0	Restart power?	Yes

Setting Explanation

Setting	Explanation
0	Use as an absolute encoder.
1	Use as an incremental encoder.

- When 1 is set, the absolute encoder operates as an incremental encoder (backup battery not necessary).

Note If encoder resolution greater than 2,048 pulses/rotation is required with a 30- to 750-W Servomotor (including Flat-style) at 3,000 r/min., you can use a Servomotor with an absolute encoder (16,384 pulses/rotation) as a Servomotor with an incremental encoder.

Pn002.3	Function selection application switch 2 — Fully-closed encoder usage method						
Setting range	0 to 4	Unit	---	Default setting	0	Restart power?	Yes

Setting Explanation

Setting	Explanation
0	Fully-closed encoder is not used.
1	Fully-closed encoder is used without phase Z.
2	Fully-closed encoder is used with phase Z.
3	Fully-closed encoder is used in reverse rotation mode without phase Z.
4	Fully-closed encoder is used in reverse rotation mode with phase Z.

- Set the application method for a fully-closed encoder when a DeviceNet Option Unit (R88A-NCW152-DRT) is mounted and a fully-closed encoder will be used.
- Always set this parameter to 0 (default) if a DeviceNet Option Unit is not mounted or a fully-closed encoder will not be used.

Note Refer to the *OMNUC W-series DeviceNet Option Unit User's Manual (I538)* for details on application methods for a fully-closed encoder (fully-closed control).

• Function Selection Application Switch 3 (Pn003: Default Setting 0002)

Pn003.0	Function selection application switch 3 — Analog monitor 1 (AM) allocation (All operation modes)						
Setting range	0 to F	Unit	---	Default setting	2	Restart power?	Yes

Pn003.1	Function selection application switch 3 — Analog monitor 2 (NM) allocation (All operation modes)						
Setting range	0 to F	Unit	---	Default setting	0	Restart power?	Yes

Setting Explanation

Setting	Explanation
0	Servomotor rotation speed (speed monitor): 1 V/1000 r/min. Forward rotation: – voltage, reverse rotation: + voltage. All operation modes
1	Speed command: 1 V/1000 r/min. Forward rotation command: – voltage, reverse rotation command: + voltage. Position, speed, internally-set speed control
2	Torque command (current monitor): 1 V/rated torque, forward acceleration: – voltage, reverse acceleration: + voltage. All operation modes
3	Position deviation: 0.05 V/1 command. Plus deviation: – voltage, minus deviation: + voltage. Position
4	Position deviation: 0.05 V/100 commands. Plus deviation: – voltage, minus deviation: + voltage. Position
5	Command pulse frequency: 1 V/1000 r/min. Forward rotation: – voltage, reverse rotation: + voltage. Position
6	Servomotor rotation speed (speed monitor): 1 V/250 r/min., Forward rotation: – voltage, reverse rotation: + voltage. All operation modes
7	Servomotor rotation speed (speed monitor): 1 V/125 r/min., Forward rotation: – voltage, reverse rotation: + voltage. All operation modes
8 to F	Not used.

- The Pn003 monitor settings are as follows: Pn003.0 is analog monitor 1 (AM: Pin CN5-2), and Pn003.1 is analog monitor 2 (NM: Pin CN5-1).
- Set values are the same as for Pn003.0 and Pn003.1.

Note 1. Displays status without offset adjustment and scaling changes. (Perform offset adjustment and scaling changes using System Check Mode.)

Note 2. The maximum analog monitor output voltage is ± 8 V. Exceeding this voltage may result in a wrong output.

Note 3. Analog monitor output accuracy is approximately $\pm 15\%$.

Pn003.2	Function selection application switch 2 — Not used.						
Setting range	---	Unit	---	Default setting	0	Restart power?	No

Note Do not change setting.

Pn003.3	Function selection application switch 2 — Not used.						
Setting range	---	Unit	---	Default setting	0	Restart power?	No

Note Do not change setting.

● **Unused Parameters (Pn004 and Pn005)**

Pn004	Not used.						
Setting range	---	Unit	---	Default setting	0000	Restart power?	No

Note Do not change setting.

Pn005	Not used.						
Setting range	---	Unit	---	Default setting	0000	Restart power?	No

Note Do not change setting.

■ **Gain Parameters (From Pn100)**

Pn100	Speed loop gain (Position, speed, internally-set speed control)						
Setting range	1 to 2000	Unit	Hz	Default setting	80	Restart power?	No

- This gain adjusts the speed loop response.
- Increase the setting (i.e., increase the gain) to raise servo rigidity. Generally, the greater the inertia ratio, the higher the setting. There is a risk of oscillation, however, if the gain is too high.

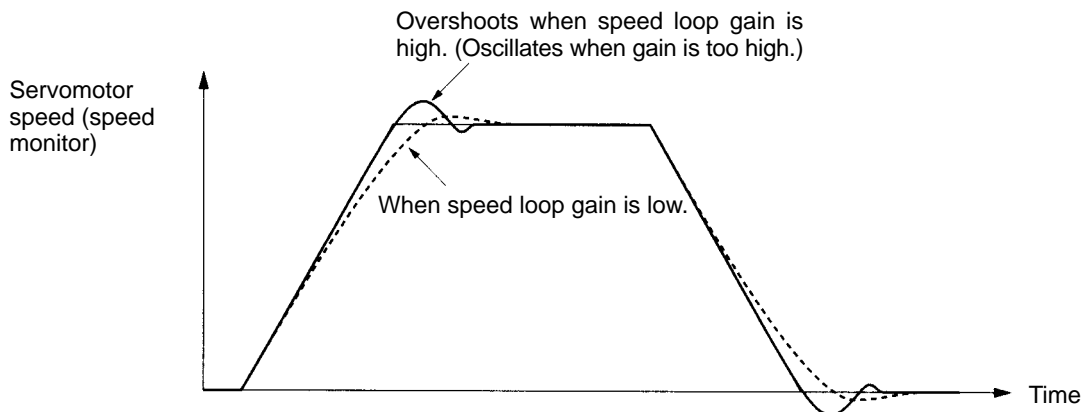

Pn101	Speed loop integration constant (Position, speed, internally-set speed control)						
Setting range	15 to 51200	Unit	x 0.01 ms	Default setting	2000	Restart power?	No

- Sets the speed loop integral time constant.
- The higher the setting, the lower the response, and the lower the resiliency to external force. There is a risk of oscillation if the setting is too low.

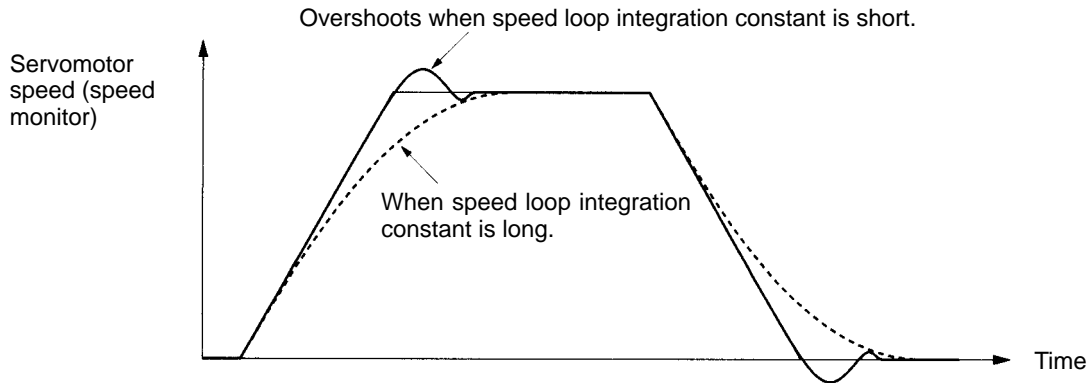

Pn102	Position loop gain (Position, speed with position lock)						
Setting range	1 to 2000	Unit	1/s	Default setting	40	Restart power?	No

- Adjust the position loop response to suit the mechanical rigidity.
- The position loop gain is enabled in speed control only if using the position lock function. Use servo-lock power adjustment during position lock.
- Servo system response is determined by the position loop gain. Servo systems with a high loop gain have a high response, and positioning is fast. To raise the position loop gain, you must improve mechanical rigidity and raise the specific oscillation. This should be 50 to 70 (1/s) for ordinary machine tools, 30 to 50 (1/s) for general-use and assembly machines, and 10 to 30 (1/s) for production robots. The default position loop gain is 40 (1/s), so be sure to lower the setting for machines with low rigidity.
- Raising the position loop gain in systems with low mechanical rigidity or systems with low specific oscillation may result in machine resonance, causing an overload alarm to occur.
- If the position loop gain is low, you can shorten the positioning time using feed forward. You can also shorten the positioning time using the bias function.

Position loop gain is generally expressed as follows:

$$\text{Position loop gain (Kp)} = \frac{\text{Command pulse frequency (pulses/s)}}{\text{Deviation counter residual pulses (pulses)}} \quad (1/s)$$

When the position loop gain is manipulated, the response is as shown in the diagram below.

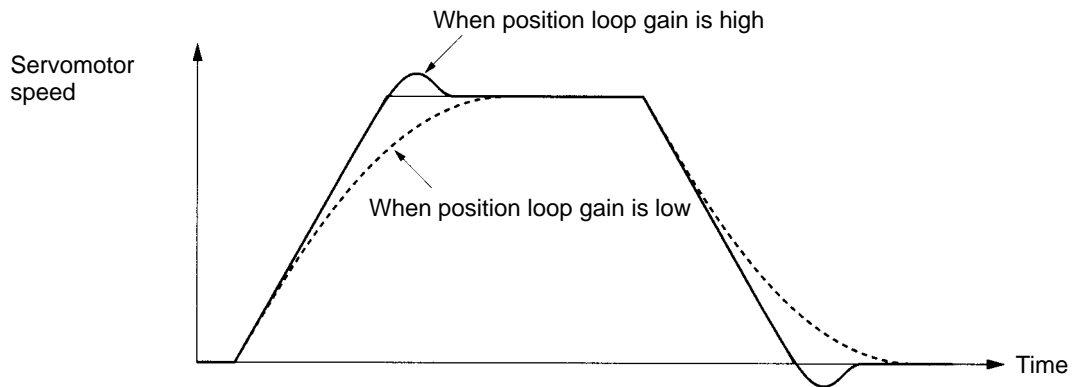

Pn103	Inertia ratio (Position, speed, internally-set speed control)						
Setting range	0 to 20000	Unit	%	Default setting	300	Restart power?	No

- Set the mechanical system inertia (load inertia for Servomotor shaft conversion) using the ratio (%) of the Servomotor rotor inertia. If the inertia ratio is set incorrectly, the Pn100 (speed loop gain) value will also be incorrect.
- This parameter is the initial online auto-tuning value. After performing online auto-tuning, the correct value will be written to Pn103 if the tuning results are saved. Refer to *4-7-1 Online Auto-tuning* for details.

Note The setting range is 0 to 10,000 when the Servo Driver software version is “r.0014” or earlier.

Pn104	No. 2 speed loop gain (Position, speed, internally-set speed control)						
Setting range	1 to 2000	Unit	Hz	Default setting	80	Restart power?	No

Pn105	No. 2 speed loop integral time constant (Position, speed, internally-set speed control)						
Setting range	15 to 51200	Unit	x 0.01 ms	Default setting	2000	Restart power?	No

Pn106	No. 2 position loop gain (Position, speed with position lock)						
Setting range	1 to 2000	Unit	1/s	Default setting	40	Restart power?	No

- These parameters are gain and time constants selected when using gain switching under the following conditions.
 - When GSEL (gain switching input) is used.
A terminal must be allocated using Pn50d.2 (input signal selection 4 — GSEL (gain switching) signal input terminal allocation). Refer to *4-8-5 Gain Switching (Position, Speed, Internally-set Speed Control)* for details.
 - When automatic gain switching is set and the switching conditions are met.
Pn10b.2 (automatic gain switching selection) must be set. Refer to *4-8-6 Automatic Gain Switching (Position Control)* for details.
- If the mechanical system inertia changes greatly or if you want to change the responsiveness for when the Servomotor is rotating and when it is stopped, you can achieve the appropriate control by setting the gain and time constant beforehand for each of these conditions, and then switch according to the conditions.

- We recommend using Racks on which online auto-tuning cannot be set to be always enabled. Online auto-tuning cannot be set to be always enabled under the following conditions.
 - When using torque feed-forward function.
 - When load inertia fluctuates by 200 ms maximum.
 - During operations where rotation speed does not exceed 500 r/min., or output torque does not exceed 50% of the rated torque.
 - When external power is constantly applied, as with the vertical axis.

Note 1. Automatic gain switching is enabled for position control only. When position control is not used, the Servomotor operates using No. 1 gain (Pn100, Pn101, Pn102).

Note 2. When automatic gain switching is used, set No. 1 gain for gain during operation, and set No. 2 gain for gain while stopped.

Note 3. Automatic gain switching and gain switching using GSEL (gain switching input) cannot be used together. When Pn10b.2 (automatic gain switching selection) is set between 1 and 3, GSEL switching is disabled.

Note 4. When No. 2 gain is selected, online auto-tuning is normally disabled.

Pn107	Bias rotational speed (Position)						
Setting range	0 to 450	Unit	r/min.	Default setting	0	Restart power?	No

Pn108	Bias addition band (Position)						
Setting range	0 to 250	Unit	r/min.	Default setting	7	Restart power?	No

- These two parameters set the position control bias.
- This function shortens the positioning time by adding the number of bias rotations to the speed command (i.e., commands to the speed control loop).
- When the deviation counter residual pulses exceed the Pn108 (bias addition band) setting, the speed set in Pn107 (bias rotational speed) is added to the speed command, and when they are within the limits for Pn108, it stops being added.

Note 1. Set Pn107 to 0 if not using bias function.

Note 2. If the bias rotation speed is too great, the Servomotor operation may become unstable. The optimum value will vary depending on the load, gain, and bias addition range, so check and adjust the Servomotor response. (Gradually increase the value, starting from Pn107 = 0.)

Bias function operation

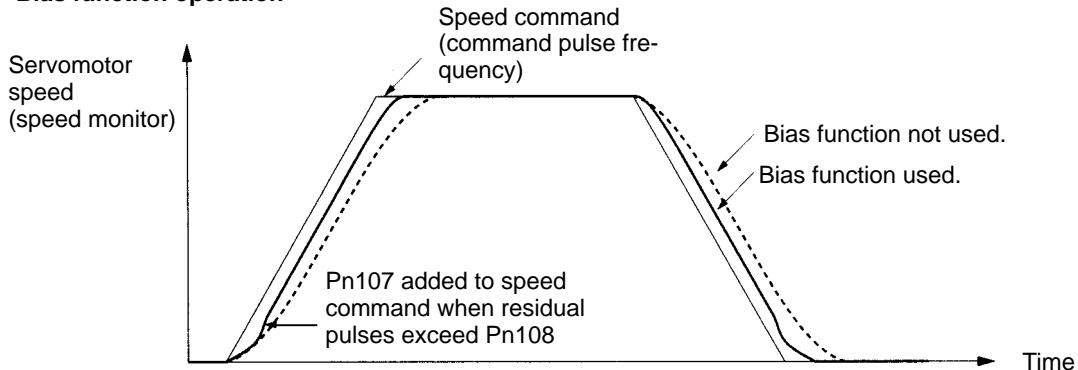

Pn109	Feed-forward amount (Position)						
Setting range	0 to 100	Unit	%	Default setting	0	Restart power?	No

- Sets the feed-forward compensation value during positioning.
- When performing feed-forward compensation, the effective servo gain rises, improving responsiveness. There is almost no effect, however, on systems where the position loop gain is sufficiently high.
- Use to shorten positioning time.

Note Setting a high value may result in machine vibration. Set the feed-forward amount for general machinery to 80% maximum. (Check and adjust machine response.)

Pn10A	Feed-forward command filter (Position)						
Setting range	0 to 6400	Unit	x 0.01 ms	Default setting	0	Restart power?	No

- Sets the feed-forward primary (lag) command filter during position control.
- If the positioning completed signal is interrupted (i.e., repeatedly turns ON and OFF) because of performing feed-forward compensation, and a speed overshoot is generated, alleviate the problem by setting the primary lag filter.

• **Speed Control Setting (Pn10b: Default Setting 0004)**

Pn10b.0	Speed control setting — P control switching conditions (Position, speed, internally-set speed control)						
Setting range	0 to 4	Unit	---	Default setting	4	Restart power?	Yes

Setting Explanation

Setting	Explanation
0	Internal torque command (Pn10C) condition (Position, speed, internally-set speed control)
1	Speed command (Pn10d) condition (Position, speed, internally-set speed control)
2	Acceleration command (Pn10E) condition (Position, speed, internally-set speed control)
3	Deviation pulse (Pn10F) condition (Position)
4	P control switching function not used. (Position, speed, internally-set speed control)

- Sets the speed control loop switching function from PI control to P control.
- Normally, using the speed loop gain and the position loop gain set by means of the auto-tuning operation will provide adequate control. (Consequently, there is normally no need to change the setting.)
- When PI control is always being used, switching to P control may help if the Servomotor speed overshoots or undershoots (i.e., the effective servo gain is reduced by switching to P control to stabilize the servo system). The positioning time can also be shortened in this way.
- If the output torque is saturated during acceleration and deceleration, set speed control to 0 (switching by internal torque command), or 2 (switching by acceleration command).
- If the speed control overshoots or undershoots without the output torque being saturated during acceleration and deceleration, set speed control to 1 (switching by speed command), or 3 (switching by deviation pulse value).
- If the setting is made from 0 to 3 (i.e., if P control switching is used), set the switching condition to Pn10C to Pn10F.

Note Setting Pn10b.1 (speed control loop switching) to 1 (IP control) changes the parameter to switch from IP control to P control.

Pn10b.1	Speed control setting — Speed control loop switching (Position, speed, internally-set speed control)						
Setting range	0, 1	Unit	---	Default setting	0	Restart power?	Yes

Setting Explanation

Setting	Explanation
0	PI control
1	IP control

- Set the speed control loop to either PI control or IP control.
- There is normally no need to change the setting.
- If you cannot shorten positioning time in PI control, change the setting to 1 (IP control).

Note Online auto-tuning does not normally operate in IP control.

Pn10b.2	Speed control setting — Automatic gain switching selection						
Setting range	0 to 3	Unit	---	Default setting	0	Restart power?	No

Setting Explanation

Setting	Explanation
0	Automatic gain switching disabled.
1	Gain switching using position commands.
2	Gain switching using position deviation.
3	Gain switching using position commands and position deviation

- Sets to enable or disable automatic gain switching.
- When automatic gain switching is used, set in Pn124 (automatic gain switching timer) the switching delay time after conditions are met.
- when position deviation is used to perform gain switching, set the amount of position deviation used as the switching condition in Pn125 (automatic gain switching width).

Note 1. Automatic gain switching is enabled for positioning control only. When positioning control is not used, the Servomotor operates using the No. 1 gain.

Note 2. When automatic gain switching is used (set value is between 1 and 3), gain switching using GSEL (gain switching input) is disabled.

Note 3. This new parameter is supported by Servo Drivers with software version “r.0037.”

Pn10b.3	Speed control setting — Not used.						
Setting range	---	Unit	---	Default setting	0	Restart power?	No

Note Do not change the setting.

Pn10C	P control switching (torque command) (Position, speed, internally-set speed control)						
Setting range	0 to 800	Unit	%	Default setting	200	Restart power?	No

- You must set Pn10C if you set Pn10b.0 (P control switching condition) to 0 (switching by internal torque command).
- Set the condition to switch to P control using Servomotor rated torque ratio (%).
- The servo switches to P control if the internal torque command exceeds the setting level.

Pn10d	P control switching (speed command) (Position, speed, internally-set speed control)						
Setting range	0 to 10000	Unit	r/min	Default setting	0	Restart power?	No

- You must set Pn10d if you set Pn10b.0 (P control switching condition) to 1 (switching by speed command).
- Set the speed to switch to P control.
- The servo switches to P control if the speed command exceeds the setting level.

Pn10E	P control switching (acceleration command) (Position, speed, internally-set speed control)						
Setting range	0 to 3000	Unit	x 10 r/min/s	Default setting	0	Restart power?	No

- You must set Pn10E if you set Pn10b.0 (P control switching condition) to 2 (switching by acceleration command).
- Set the acceleration to switch to P control.
- The servo switches to P control if the acceleration command value exceeds the setting level.

Pn10F	P control switching (deviation pulse)						
Setting range	0 to 10000	Unit	Command unit	Default setting	10	Restart power?	No

- You must set Pn10F if you set Pn10b.0 (P control switching condition) to 3 (switching by deviation pulse).
- Set the deviation pulse to switch to P control.
- The servo switches to P control if the deviation counter residual pulses exceed the setting level.

• **Online Auto-tuning Setting (Pn110: Default Setting 0012)**

- Online auto-tuning is a control function that constantly maintains the target speed loop gain and position loop gain using the operating load inertia measured by the Servo Driver. Use this function to adjust the gain easily even if you are using a servo system for the first time.
- The following four user parameters are set automatically by online auto-tuning.
 - Pn100: Speed loop gain
 - Pn101: Speed loop integration time constant
 - Pn102: Position loop gain
 - Pn401: Torque command filter time constant

Note You cannot use online auto-tuning in the following cases.

- Control using torque command mode.
- Speed control loop using IP control (Pn10b.1 = 1)
- Control using the No. 2 gain (when GSEL (gain switching input) is input or automatic gain switching is used).

- Using torque feed-forward function (Pn002.0 = 2)
- Using speed feedback compensation function (Pn110.1 = 0)

Note Refer to 4-7-1 *Online Auto-tuning* for details.

Pn110.0	Online auto-tuning setting — Online auto-tuning selection (Position, speed, internally-set speed control)						
Setting range	0 to 2	Unit	---	Default setting	2	Restart power?	Yes

Setting Explanation

Setting	Explanation
0	After the power is turned ON, auto-tuning is only performed for the initial operation.
1	Auto-tuning is always performed.
2	Auto-tuning is not used.

- Select the auto-tuning function you want to use.
- 0: After the power is turned ON, execute auto-tuning and, when the load inertia calculations are complete, use the data for control. Thereafter, do not perform auto-tuning again whenever the power is turned ON. Make this setting if load inertia fluctuation is small.
- 1: Constantly refresh the load inertia calculation data and constantly store the responses. Make this setting if load inertia fluctuates constantly.
- 2: Do not execute auto-tuning. Make this setting if you cannot use auto-tuning (see above), or if adjusting the gain manually. Also set this parameter to 2 if load inertia fluctuation is small, and if, having once calculated load inertia using auto-tuning (setting: 0), you wish to perform subsequent control using the same conditions after having saved the auto-tuning results to memory (System Check Mode operation).
- Make this setting 0 or 2 if auto-tuning is disabled. (See above.)
 - When load inertia fluctuates by 200 ms maximum.
 - During operations where rotation speed does not exceed 500 r/min., or output torque does not exceed 50% of the rated torque.
 - When external power is constantly applied, as with the vertical axis.

Pn110.1	Online auto-tuning setting — Speed feedback compensation function selection (Position, speed, internally-set speed control)						
Setting range	0, 1	Unit	---	Default setting	1	Restart power?	Yes

Setting Explanation

Setting	Explanation
0	Speed feedback compensation function ON
1	Speed feedback compensation function OFF

- This function shortens positioning time.
- Use this function to lower speed loop feedback gain, and to raise speed loop gain and position loop gain. In this way, you can improve command responsiveness and shorten positioning time. Positioning time cannot be shortened, however, when external force is applied as with the vertical shaft, because responsiveness to external interference is lowered.

- If 0 (function ON) is set, set Pn111 (speed feedback compensating gain).

Note If using online auto-tuning, set this parameter to 1 (function OFF). If using speed feedback compensation function, online auto-tuning is disabled.

Pn110.2	Online auto-tuning function — Adhesive friction compensation function selection (Position, speed, internally-set speed control)						
Setting range	0 to 2	Unit	---	Default setting	0	Restart power?	Yes

Setting Explanation

Setting	Explanation
0	Friction compensation: None (when adhesive friction for rated revolutions is 10% max. of rated torque)
1	Friction compensation: Rated torque ratio: Small (when adhesive friction for rated rotation speed is 10% to 30% of rated torque)
2	Friction compensation: Rated torque ratio: Large (when adhesive friction for rated rotation speed is 30% to 50% of rated torque)

- When calculating load inertia using online auto-tuning, set whether the effects of adhesive friction (load torque proportional to rotation speed) on the servo system should be considered.
- If adhesive friction is to be considered, set whether the adhesive friction is large or small to improve the accuracy of the load inertia calculations.

Note If the adhesive friction on the rated rotation speed is 10% max. of the rated torque, set this parameter to 0 (No friction compensation).

Pn110.3	Online auto-tuning setting — Not used.						
Setting range	---	Unit	---	Default setting	0	Restart power?	No

Note Do not change the setting.

Pn111	Speed feedback compensating gain (Position, speed, internally-set speed control)						
Setting range	1 to 500	Unit	%	Default setting	100	Restart power?	No

- Use this parameter to adjust the speed loop feedback gain for when Pn110.1 (speed feedback compensation function selection) is set to ON.
- The smaller the setting, the higher you can raise the speed loop gain and position loop gain. If the setting is too small, however, responses may be unstable.

Note 1. Correctly set Pn103 (inertia ratio), perform the usual manual adjustment, then adjust the speed feedback compensation. After manual adjustment, manually readjust the setting to approximately 90%. Then, readjust repeatedly while gradually reducing the setting to find the optimum setting.

Note 2. If using speed feedback compensation function, online auto-tuning is disabled.

Note 3. Refer to 4-8-8 *Speed Feedback Compensation* for details.

• Unused Gain Parameters (Pn 112 to Pn123)

Note Do not change the settings of the following parameters.

Pn112	Not used.	Default setting	100
Pn113	Not used.	Default setting	1000
Pn114	Not used.	Default setting	200
Pn115	Not used.	Default setting	32
Pn116	Not used.	Default setting	16
Pn117	Not used.	Default setting	100
Pn118	Not used.	Default setting	100
Pn119	Not used.	Default setting	50
Pn11A	Not used.	Default setting	1000
Pn11b	Not used.	Default setting	50
Pn11C	Not used.	Default setting	70
Pn11d	Not used.	Default setting	100
Pn11E	Not used.	Default setting	100
Pn11F	Not used.	Default setting	0
Pn120	Not used.	Default setting	0
Pn121	Not used.	Default setting	50
Pn122	Not used.	Default setting	0
Pn123	Not used.	Default setting	0

● **Automatic Gain Switching (Pn124 to Pn125)**

Pn124	Automatic gain switching timer						
Setting range	1 to 10000	Unit	ms	Default setting	100	Restart power?	No

- When Pn10b.2 (automatic gain switching selection) is set between 1 and 3, this parameter sets the switching delay time after conditions are completed.

Note 1. For details on automatic gain switching, refer to *4-8-6 Automatic Gain Switching (Position Control)*.

Note 2. This new parameter is supported by Servo Drivers with software version “r.0037.”

Pn125	Automatic gain switching width (amount of position deviation)						
Setting range	1 to 250	Unit	Command unit	Default setting	7	Restart power?	No

- This parameter sets the amount of position deviation used for the switching condition when automatic gain switching is performed using position deviation (Pn10b.2 = 2, 3).

Note 1. For details on automatic gain switching, refer to *4-8-6 Automatic Gain Switching (Position Control)*.

Note 2. This new parameter is supported by Servo Drivers with software version “r.0037.”

■ **Position Control Parameters (From Pn200)**

● **Position Control Setting 1 (Pn200: Default Setting 1011)**

Pn200.0	Position control setting 1 — Command pulse mode (Position)						
Setting range	0 to 9	Unit	---	Default setting	1	Restart power?	Yes

Note Refer to 4-4-3 *Important Parameters* for details.

Pn200.1	Position control setting 1 — Deviation counter reset (Position)						
Setting range	0 to 3	Unit	---	Default setting	1	Restart power?	Yes

Setting Explanation

Setting	Explanation
0	Reset deviation counter using high level signal (status signal)
1	Reset deviation counter using rising signal (Low to High)
2	Reset deviation counter using low level signal (status signal)
3	Reset deviation counter using sinking signal (High to Low)

- Sets input conditions under which ECRST (deviation counter reset input, CN1-15: +ECRST, CN1-14: -ECRST) is enabled.
- If using an OMRON Position Control Unit, do not change the default setting.

Pn200.2	Position control setting 1 — Deviation counter reset when servo is OFF and an alarm occurs (Position)						
Setting range	0 to 2	Unit	---	Default setting	0	Restart power?	Yes

Setting Explanation

Setting	Explanation
0	Reset deviation counter when servo is OFF and an alarm occurs
1	Do not reset deviation counter when servo is OFF and an alarm occurs
2	Reset deviation counter if alarm occurs, regardless of servo status

- Sets whether the deviation counter will be reset when the servo is OFF and an alarm occurs.
- If the deviation counter is not reset (setting 1 or 2), the next time the servo is turned ON, the Servomotor will rotate only to the number of deviation counter residual pulses. Be careful, because the servo begins to operate as soon as the power is turned ON.

Pn200.3	Position control setting 1 — Pulse command filter selection						
Setting range	0, 1	Unit	---	Default setting	1	Restart power?	Yes

Setting Explanation

Setting	Explanation
0	Command filter for line driver signal input (500 kpps)
1	Command filter for open collector signal input (200 kpps)

- Sets the pulse command input filter.
- Set this parameter to conform to the command pulse input (line driver input or open-collector input).

Pn201	Encoder dividing rate (All operation modes)						
Setting range	16 to 16384	Unit	Pulses/rotation	Default setting	1000	Restart power?	Yes

- Sets the number of output pulses from the Servo Driver.
- The encoder resolution for each Servomotor is shown below. Set the resolution as the upper limit.

INC

- 3,000 r/min. Servomotor (30 to 750 W): 2,048 pulses/rotation
- 3,000 r/min. Servomotor (1 to 5 kW): 32,768 pulses/rotation
- 3,000 r/min. flat-type Servomotor: 2,048 pulses/rotation
- 1,000 r/min. Servomotor: 32,768 pulses/rotation

ABS

- 3,000 r/min. Servomotor (30 to 750 W): 16,384 pulses/rotation
- 3,000 r/min. Servomotor (1 to 5 kW): 32,768 pulses/rotation
- 3,000 r/min. flat-type Servomotor: 16,384 pulses/rotation
- 1,000 r/min. Servomotor: 32,768 pulses/rotation
- 1,500 r/min. Servomotor: 32,768 pulses/rotation

- Note 1.** Even if encoder resolution is 32,768 (pulses/rotation), the maximum setting is 16,384 (pulses/rotation).
- Note 2.** If you set a value greater than the encoder resolution, the resolution setting will taken to be the encoder resolution.
- Note 3.** If using an OMRON Position Control Unit (analog voltage output type) or Motion Control Unit, the upper limit of the encoder dividing rate is the rotation speed used. Refer to *Encoder Dividing Rate and Rotations Using OMRON Servo Controllers* for details.
- Note 4.** Refer to 4-5-7 *Encoder Dividing Function* for details.

Pn202	Electronic gear ratio G1 (numerator) (Position)						
Setting range	1 to 65535	Unit	---	Default setting	4	Restart power?	Yes

Pn203	Electronic gear ratio G2 (denominator) (Position)						
Setting range	1 to 65535	Unit	---	Factory	1	Restart power?	Yes

- Sets the command pulses and Servomotor travel distance pulse rate.
- When $G1/G2 = 1$, if an (encoder resolution x 4) pulse is input, the Servomotor will rotate once (the internal Servo Driver will operate at x4).
- Set within the range $0.01 \leq G1/G2 \leq 100$.

Note Refer to 4-5-12 *Electronic Gear Function* for details.

Pn204	Position command filter time constant 1 (primary filter)						
Setting range	0 to 6400	Unit	x 0.01 ms	Default setting	0	Restart power?	No

- Sets the command pulse soft start. The soft start property is the primary filter (exponentiation function).

Note 1. The soft start properties also include linear acceleration and deceleration. (Set the time constant using Pn208.) Select the filter you want to use using Pn207.0 (position command filter selection).

Note 2. Refer to 4-5-13 *Position Command Filter Function* for details.

Pn205	Absolute encoder multi-turn limit setting (All operation modes) (ABS)						
Setting range	0 to 65535	Unit	Rotation	Default setting	65535	Restart power?	Yes

- Sets the amount of multi-turn rotation when using a Servomotor with an absolute encoder.
- If using an absolute encoder, the counter counts the number of rotations from the setup position, and outputs the number of rotations from the Servo Driver (When SEN signal is input, output from CN1-48: + absolute, or CN1-49 – absolute).
- With the default setting (Pn205 = 65535), the Servomotor multi-turn data will be as follows:

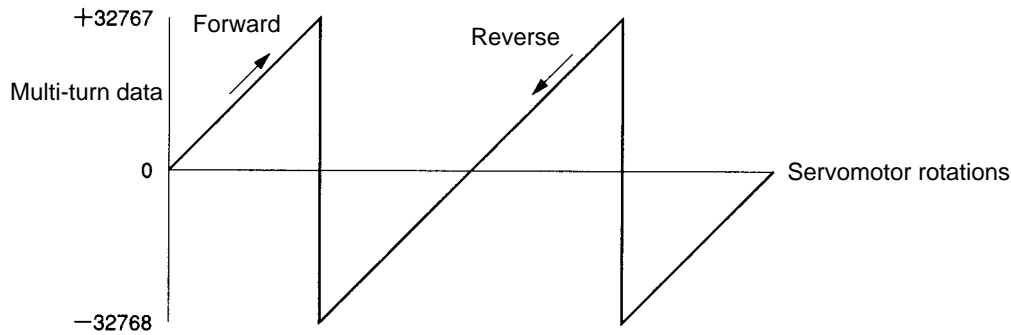

- With the default settings changed (i.e., Pn205 ≠ 65535), the Servomotor multi-turn data will be as follows:

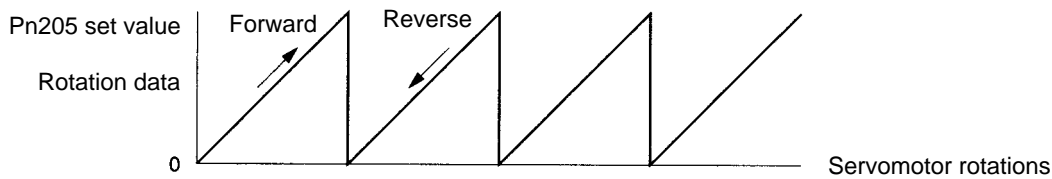

That is, when the default settings are changed (i.e., Pn205 ≠ 65535), the Servomotor multi-turn data will be only in the positive direction. If you want to set the multi-turn limit as high as possible, with the entire operating area positive, set a number such as 65534.

To return the multi-turn data to 0 each time the motor (e.g., turntable) completes m rotations, set the value (m-1) in Pn205. For example, if the machine's gear ratio is 1/33, set 32 in Pn205 to return the multi-turn data to 0 after 33 rotations.

Note If Pn205 is changed, the limit to the number of rotations in the encoder memory and the limit to the number of rotations in the Servo Driver memory will no longer agree, so an A.CC alarm (multi-turn limit nonconformity) will be generated. To cancel this alarm, the setting for the number of multi-turns (Fn013) must be changed in the System Check Mode.

Pn206	Number of fully-closed encoder pulses (Option)						
Setting range	25 to 65535	Unit	Pulses/rotation	Default setting	16384	Restart power?	Yes

- Set the number of pulses per motor rotation for a fully-closed encoder when a DeviceNet Option Unit (R88A-NCW152-DRT) is mounted and a fully-closed encoder will be used.
- This parameter is valid whenever Pn002.3 (Application Method for Full Closed-loop Encoder) is not set to 0.
- Do not change the default setting when using a Servo Driver alone without a DeviceNet Option Unit or when not using a fully-closed encoder.
- The lower limit of the setting range is 25, but always set a value of 513 or higher (and select a fully-closed encoder to enable this). An A.04 alarm (parameter setting error) may occur if a value less than 513 is set.

Note Refer to the *OMNUC W-series DeviceNet Option Unit User's Manual (I538)* for details on application methods for a fully-closed encoder (fully-closed loop control).

• **Position Control Setting 2 (Pn207: Default Setting 0000)**

Pn207.0	Position control setting 2 — Position command filter selection (Position)						
Setting range	0, 1	Unit	---	Default setting	0	Restart power?	Yes

Setting Explanation

Setting	Explanation
0	Primary filter (Set Pn204 properties)
1	Linear acceleration and deceleration (set Pn208 properties)

- Select the command pulse soft start properties.
- Select 0 to allocate the properties to Pn204 (position command filter time constant 1), and select 1 to allocate the properties to Pn208 (position command filter time constant 2).
- If not using the soft start function, set the properties for the selected filter to 0.

Note Refer to *4-5-13 Position Command Filter Function* for details.

Pn207.1	Position control setting 2 — Speed command input switching for position control (Position)						
Setting range	0, 1	Unit	---	Default setting	0	Restart power?	Yes

Setting Explanation

Setting	Explanation
0	Function not used.
1	REF used as feed-forward input

- Set the REF function (speed command input) for position control.
- Select 1 to input the REF voltage speed feed-forward input, and add the speed equivalent to the speed REF voltage to the speed loop command. This can shorten positioning time.
- You can change the REF voltage scale using Pn300 (speed control scale). (Default setting: 10 V/rated rotations.)
- If using an OMRON Positioning Unit (pulse train output type), set this parameter to 0 (function not used).

Note Refer to 4-8-4 Speed Feed-forward Function for details.

Pn207.2	Position control function 2 — Not used.						
Setting range	---	Unit	---	Default setting	0	Restart power?	No

Note Do not change the setting.

Pn207.3	Position control function 2 — Not used.						
Setting range	---	Unit	---	Default setting	0	Restart power?	No

Note Do not change the setting.

Pn208	Position command filter time constant 2 (linear acceleration and deceleration)						
Setting range	0 to 6400	Unit	x0.01 ms	default setting	0	Restart power?	No

- Sets the command pulse soft start. The soft start properties are linear acceleration and deceleration.

Note 1. The soft start properties also include the primary filter (the time constant set by Pn204). Select the filter you want to use using Pn207.0 (position command filter selection).

Note 2. Refer to 4-5-13 Position Command Filter Function for details.

Pn212	Not used.						
Setting range	---	Unit	---	default setting	2048	Restart power?	No

Note 1. Do not change the setting.

Note 2. This new parameter is supported by Servo Drivers with software version “r.0037.”

Pn217	Command pulse factor						
Setting range	1 to 99	Unit	Factor	default setting	1	Restart power?	No

- Sets the factor (1 to 99) for the position command pulse when command pulse factor switching is used.
- Command pulse factor switching uses external signals (control input) during operation to switch the multiplying factor of the position command pulse ($\times 1$ to \times set value in Pn217).
- Enabled when Pn218.0 (command pulse factor switching selection) is set to 1.
- Set Pn513.0 (PSEL signal input terminal allocation) and Pn510.2 (PSON signal output terminal allocation) to appropriate values.
- If the PSEL (command pulse factor switching) input is set to ON when command pulse factor switching is used, the Servo Driver will rotate the Servomotor using the position command pulse \times Pn217 as the command pulse.

Note 1. For details on timing of command pulse factor switching, refer to the pages on the PSEL (command pulse factor switching) signal under 2-4-4 Control I/O Specifications (CN1).

Note 2. This new parameter is supported by Servo Drivers with software version “r.0037.”

• Position Control Setting 3 (Pn218: Default Setting 0000)

Pn218.0	Position control setting 3 — Command pulse factor switching selection						
Setting range	0, 1	Unit	---	Default setting	0	Restart power?	Yes

Setting Explanation

Setting	Explanation
0	Function not used.
1	Rotates Servomotor using the command pulse multiplied by the factor set in Pn217.

- Selects whether command pulse factor switching is used.
- When 1 is selected, set appropriate values for Pn217 (command pulse factor), Pn513 (PSEL signal input terminal allocation), and Pn510.2 (PSON signal output terminal allocation).

Note 1. For details on timing of command pulse factor switching, refer to the pages on the PSEL (command pulse factor switching) signal under *2-4-4 Control I/O Specifications (CN1)*.

Note 2. This new parameter is supported by Servo Drivers with software version “r.0037.”

Pn218.1	Position control setting 3 — Not used.						
Setting range	---	Unit	---	Default setting	0	Restart power?	No

Note Do not change the setting.

Pn218.2	Position control setting 3 — Not used.						
Setting range	---	Unit	---	Default setting	0	Restart power?	No

Note Do not change the setting.

Pn218.3	Position control setting 3 — Not used.						
Setting range	---	Unit	---	Default setting	0	Restart power?	No

Note Do not change the setting.

■ **Speed Control Parameters (From Pn300)**

Pn300	Speed command scale (All operation modes)						
Setting range	150 to 3000	Unit	0.01 V/ rated rotations	Default setting	1000	Restart power?	No

- This parameter sets the relationship between REF (speed command input) voltage and Servomotor rotation speed.
- Set REF voltage for operating at the rated rotation speed.
- The default setting is for the rated rotation speed at an REF voltage of 10 V.

Note REF voltage functions as the input voltage shown below using control mode and parameter settings.

- During speed control: Speed command inputs
- During torque control: analog speed limits (when Pn002.1 = 1)
- During position control: Speed feed-forward inputs (when Pn207.1 = 1)

Pn301	No. 1 internal speed setting						
Setting range	0 to 10000	Unit	r/min.	Default setting	100	Restart power?	No

Pn302	No. 2 internal speed setting						
Setting range	0 to 10000	Unit	r/min.	Default setting	200	Restart power?	No

Pn303	No. 3 internal speed setting						
Setting range	0 to 10000	Unit	r/min.	Default setting	300	Restart power?	No

- These parameters set the speed when using internally-set speed control.
- The speed setting is selected by the ON/OFF status of SPD1 and SPD2 (speed selection command inputs 1 and 2), and the direction of rotation is selected by RDIR (rotation direction command input).

Note 1. If a value that exceeds the maximum Servomotor rotation speed is set, that value will be regarded as the maximum Servomotor rotation speed.

Note 2. Refer to 4-5-4 *Internally Set Speed Control* for details.

Pn304	Jog speed (All operation modes)						
Setting range	0 to 10000	Unit	r/min.	Default setting	500	Restart power?	No

- Sets the speed for when the jog operation is used.

Note 1. If a value that exceeds the maximum Servomotor rotation speed is set, that value will be regarded as the maximum Servomotor rotation speed.

Note 2. Refer to 4-3-2 *Jog Operation* for details.

Pn305	Soft start acceleration time (Speed, internally-set speed control)						
Setting range	0 to 10000	Unit	ms	Default setting	0	Restart power?	No

Pn306	Soft start deceleration time (Speed, internally-set speed control)						
Setting range	0 to 10000	Unit	ms	Default setting	0	Restart power?	No

- Sets the acceleration and deceleration time for soft start using speed control.
- Set the acceleration time from Servomotor rotation speed = 0 (r/min.) to the maximum rotation speed in Pn305, and set the deceleration time from the maximum rotation speed to the Servomotor rotation speed = 0 (r/min.) in Pn306.
- Set both Pn305 and Pn306 to 0 if using a position controller with acceleration and deceleration functions, or if not using speed control and internally-set speed control.

Note Refer to 4-5-11 *Soft Start Function* for details.

Pn307	Speed command filter time constant (All operation modes)						
Setting range	0 to 65535	Unit	x 0.01 ms	Default setting	40	Restart power?	No

- Sets the REF (speed command input) voltage (primary) filter time constant.
- Set if the Servomotor rotation speed is fluctuating due to REF voltage noise. (Set the value as small as possible to minimize the effects of noise. If the setting is too large, responsiveness will be reduced.)

Pn308	Speed feedback filter time constant (Position, speed, internally-set speed control)						
Setting range	0 to 65535	Unit	x 0.01 ms	Default setting	0	Restart power?	No

- Sets the filter time constant (primary filter) for speed feedback.
- Set this parameter if the speed loop gain cannot be raised due to factors such as mechanical system vibration.

Note When speed feedback filter is set, online auto-tuning does not operate normally.

Pn309	Not used.						
Setting range	---	Unit	---	default setting	60	Restart power?	No

Note 1. Do not change the setting.

Note 2. This new parameter is supported by Servo Drivers with software version “r.0037.”

■ Torque Control Parameters (From Pn400)

Pn400	Torque command scale (All operation modes)						
Setting range	10 to 100	Unit	0.1 V/rated torque	Default setting	30	Restart power?	No

- This parameter sets the relationship between TREF (torque command input) voltage and output torque.
- Set the TREF voltage to output the rated torque.
- The default setting is for a rated torque at TREF 3 V.

Note TREF voltage functions as an input voltage according to the control mode and parameter settings, as shown below.

- Torque control: torque command input
- Position and speed control: analog torque limit (when Pn002.0 = 1 or 3).

Torque feed-forward input (when Pn002.0 = 2)

Pn401	Torque command filter time constant (All operation modes)						
Setting range	0 to 65535	Unit	x 0.01 ms	Default setting	40	Restart power?	No

- Sets the (primary) filter time constant for the internal torque command.

When the mechanical resonance frequency is within the response frequency of the servo loop, Servomotor vibration will occur. In order to prevent this from occurring, set the torque command filter time constant.

The relationship between the filter time constant and the cut-off frequency can be found by means of the following formula:

$$f_c \text{ (Hz)} = 1 / (2\pi T) \quad : T = \text{Filter time constant (s), } f_c: \text{cut-off frequency.}$$

Set the cut-off frequency to below the mechanical resonance frequency.

- Also make this setting if the Servomotor rotation speed is fluctuating in Torque Control Mode due to TREF voltage noise. (Set the value as low as possible to minimize the effects of noise. If the setting is too high, responsiveness will be lowered.)

Pn402	Forward torque limit (All operation modes)						
Setting range	0 to 800	Unit	%	Default setting	350	Restart power?	No

Pn403	Reverse torque limit (All operation modes)						
Setting range	0 to 800	Unit	%	Default setting	350	Restart power?	No

- Set Pn402 (forward torque limit) and Pn403 (reverse torque limit) using the ratio (%) of the Servomotor rated torque for each.

Note These following torque limit functions are available: Analog torque limit (Pn002.0 = 1 or 3), Pn402 (forward torque limit), Pn403 (reverse torque limit), Pn404 (forward rotation external current limit), and Pn405 (reverse rotation external current limit). The output torque is limited by the smallest of the enabled limit values. Refer to *4-5-10 Torque Limit Function* for details.

Pn404	Forward rotation external current limit (All operation modes)						
Setting range	0 to 800	Unit	%	Default setting	100	Restart power?	No

Pn405	Reverse rotation external current limit (All operation modes)						
Setting range	0 to 800	Unit	%	Default setting	100	Restart power?	No

- Set in Pn404 the torque limit for when PCL (forward current limit input) is input, and set in Pn405 the torque limit for when NCL (reverse current limit input) is input, using the ratio (%) of the Servomotor rated torque for each.

Note The following torque limit functions are available: Analog torque limit (Pn002.0 = 1 or 3), Pn402 (forward torque limit), Pn403 (reverse torque limit), Pn404 (forward rotation external current limit), and Pn405 (reverse rotation external current limit). The output torque is limited by the smallest of the enabled limit values. Refer to *4-5-10 Torque Limit Function* for details.

Pn406	Emergency stop torque (Position, control, and internally-set speed control)						
Setting range	0 to 800	Unit	%	Default setting	350	Restart power?	No

- Set the deceleration torque if overtravel occurs using the ratio (%) of the Servomotor rated torque.

Note This parameter is enabled when Pn001.1 (Stop selection for drive prohibition is input) is set to 1 or 2 (i.e., stop using Pn406).

Pn407	Speed limit (Torque)						
Setting range	0 to 10000	Unit	r/min.	Default setting	3000	Restart power?	No

- Set the speed limit for Torque Control Mode.

Note The following speed limit functions are available: Analog speed limit (when Pn002.1 = 1), and Pn407 (speed limit). The speed limit is set to whichever is the smaller. Refer to *4-5-10 Torque Limit Function* for details.

• **Torque Command Setting (Pn408: Default Setting 0000)**

Pn408.0	Torque command setting — Notch filter 1 function selection (All operation modes)						
Setting range	0, 1	Unit	---	Default setting	0	Restart power?	No

Setting Explanation

Setting	Explanation
0	Notch filter 1 function not used.
1	Notch filter 1 used in torque commands. (Set the frequency using Pn409, and set the Q value using Pn40A).

- Set whether or not to use notch filter 1 for internal torque commands (current loop commands).
- Use the notch filter to prevent mechanical resonance. This function can be used to raise the speed loop gain and to shorten positioning time.

Note 1. With W-series AC Servo Drivers, two notch filters can be set: notch filter 1 and notch filter 2.

Note 2. For details on notch filters, refer to *4-8-7 Notch Filter (Position, Speed, Internally-set Speed Control)*.

Pn408.1	Torque command setting — Not used.						
Setting range	---	Unit	---	Default setting	0	Restart power?	No

Note Do not change the setting.

Pn408.2	Torque command setting — Notch filter 2 function selection						
Setting range	0, 1	Unit	---	Default setting	0	Restart power?	No

Setting Explanation

Setting	Explanation
0	Notch filter 2 function not used.
1	Notch filter 2 used in torque commands. (Set the frequency using Pn40b, and set the Q value in Pn40C.)

- Set whether or not to use notch filter 2 for internal torque commands (current loop commands).
- Use the notch filter to prevent mechanical resonance. This function can be used to increase the speed loop gain and to shorten positioning time.

Note 1. With W-series AC Servo Drivers, two notch filters can be set: notch filter 1 and notch filter 2.

Note 2. For details on notch filters, refer to *4-8-7 Notch Filter (Position, Speed, Internally-set Speed Control)*.

Note 3. This new parameter is supported by Servo Drivers with software version “r.0037.”

Pn408.3	Torque command setting — Not used.						
Setting range	---	Unit	---	Default setting	0	Restart power?	No

Note Do not change the setting.

Pn409	Notch filter 1 frequency						
Setting range	50 to 2000	Unit	Hz	Default setting	2000	Restart power?	No

- Enabled when Pn408.0 (notch filter 1 function selection) is set to 1.
- Sets the mechanical resonance frequency.

Note For details on notch filters, refer to *4-8-7 Notch Filter (Position, Speed, Internally-set Speed Control)*.

Pn40A	Notch filter 1 Q value						
Setting range	50 to 400	Unit	x0.01	Default setting	70	Restart power?	No

- Enabled when Pn408.0 (notch filter 1 function selection) is set to 1.
- Sets the Q value for notch filter 1.

Note 1. For details on notch filters, refer to *4-8-7 Notch Filter (Position, Speed, Internally-set Speed Control)*.

Note 2. This new parameter is supported by Servo Drivers with software version “r.0037.”

Pn40b	Notch filter 2 frequency						
Setting range	50 to 2000	Unit	Hz	Default setting	2000	Restart power?	No

- Enabled when Pn408.2 (notch filter 2 function selection) is set to 1.
- Sets the mechanical resonance frequency.

Note 1. For details on notch filters, refer to *4-8-7 Notch Filter (Position, Speed, Internally-set Speed Control)*.

Note 2. This new parameter is supported by Servo Drivers with software version “r.0037.”

Pn40C	Notch filter 2 Q value						
Setting range	50 to 400	Unit	x0.01	Default setting	70	Restart power?	No

- Enabled when Pn408.2 (notch filter 2 function selection) is set to 1.
- Sets the Q value for notch filter 2.

Note 1. For details on notch filters, refer to *4-8-7 Notch Filter (Position, Speed, Internally-set Speed Control)*.

Note 2. This new parameter is supported by Servo Drivers with software version “r.0037.”

■ Sequence Parameters (From Pn500)

Pn500	Positioning completion range 1						
Setting range	0 to 250	Unit	Command unit	Default setting	3	Restart power?	No

- Set the deviation counter to output INP1 (positioning completed output 1) during position control.
- INP1 is ON when Pn500 is below the deviation counter residual pulse.

Note Related parameters: Pn50E.0 (INP1 signal output terminal allocation), Pn504 (positioning completed range 2).

Pn501	Position lock rotation speed						
Setting range	0 to 10000	Unit	r/min.	Default setting	10	Restart power?	No

- Set the number of position lock rotations during speed control.

- When the Servomotor rotation speed is below the set value and PLOCK (position lock command input) is input, the operation mode switches from speed control to position control, and the Servomotor is locked.
- Use Pn102 (position loop gain) to adjust servolock force.

Note Related parameters: Pn50A.0 (input signal allocation mode), and Pn50d.0 (PLOCK signal input terminal allocation).

Pn502	Rotation speed for motor rotation detection						
Setting range	0 to 10000	Unit	r/min.	Default setting	20	Restart power?	No

- Set the rotation speed for outputting TGON (Servomotor rotation detection output).
- TGON turns ON when the Servomotor rotation speed is greater than the set value.

Note Related parameter: Pn50E.2 (TGON signal output terminal allocation).

Pn503	Speed conformity signal output width						
Setting range	0 to 100	Unit	r/min.	Default setting	10	Restart power?	No

- Set the allowable fluctuation range (rotation speed) for outputting VCMP (speed conformity output) during speed control.
- VCMP turns ON when the difference between the speed command value and Servomotor rotation speed is less than the set value.

Note Related parameter: Pn50E.1 (VCMP signal output terminal allocation).

Pn504	Positioning completion range 2						
Setting range	1 to 250	Unit	Command unit	Default setting	3	Restart power?	No

- Set the deviation counter to output INP2 (positioning completed output 2) during position control.
- INP2 is ON when the deviation counter residual pulses are less than the set value.
- You can reduce processing time by, for example, using INP2 as a near signal output, and receiving near signals and preparing the next sequence by the time positioning is complete (i.e., by the time INP1 turns ON). In this example, Pn504 is set higher than Pn500.

Note Related parameters: Pn510.0 (INP2 signal output terminal allocation), and Pn500 (positioning completion range 1).

Pn505	Deviation counter overflow level						
Setting range	1 to 32767	Unit	x 256 command unit	Default setting	1024	Restart power?	No

- Set the deviation counter overload alarm detection level during position control.
- The servo alarm is turned ON when the deviation counter residual pulse setting is exceeded.
- Set this parameter to an appropriate number of command units (2 to 3 rotations), giving due consideration to the system and operation patterns.

Pn506	Brake timing 1 (all operation modes)						
Setting range	0 to 50	Unit	x 10 ms	Default setting	0	Restart power?	No

Pn507	Brake command speed						
Setting range	0 to 10000	Unit	r/min.	Default setting	100	Restart power?	No

Pn508	Brake timing 2 (all operation modes)						
Setting range	10 to 100	Unit	x 10 ms	Default setting	50	Restart power?	No

- This parameter sets the BKIR (brake interlock output) timing to control the electromagnetic brake ON/OFF when a Servomotor with a brake is used.
- This setting prevents damage to the machinery and the Servomotor holding brake.
- PN506 (brake timing 1): Set the lag time from BKIR OFF to servo OFF.
- Pn507 (brake command speed): Set the rotation speed for turning OFF BKIR.
- Pn508 (brake timing 2): Set the standby time from servo OFF to BKIR OFF.
- When RUN is OFF while the Servomotor is stopped, first turn OFF BKIR, wait for the duration set in Pn506, then turn OFF the servo.
- When RUN is OFF while the Servomotor is stopped, if a servo alarm occurs, and the main circuit power supply is OFF, the Servomotor will decelerate and the rotation speed will fall. When the rotation speed falls to below the Pn507 setting, BKIR will be turned OFF.

Note 1. Related parameter: Pn50F.2 (BKIR signal output terminal allocation).

Note 2. Refer to *Brake Interlock* for details of brake interlock functions.

Pn509	Momentary hold time (All operation modes)						
Setting range	20 to 1000	Unit	ms	Default setting	20	Restart power?	No

- Sets the time during which alarm detection is disabled if a momentary power failure occurs.
- When the power supply voltage to the Servo Driver is OFF, the Servo Driver detects that the power supply is OFF and turns OFF the servo. The 20 ms default setting means that if the power supply voltage is recovered within 20 ms, operation will continue without the servo being turned OFF.
- In the following cases, the servo is turned OFF regardless of the Pn509 setting:
 - If the load is too great, and A.41 (insufficient voltage) occurs during a momentary power stoppage.
 - If the control power supply falls during a momentary power stoppage, and cannot be controlled.

Pn50A	Input signal selection 1 (All operation modes)	Default setting	8100	Restart power?	Yes
--------------	--	-----------------	------	----------------	-----

Pn50b	Input signal selection 2 (All operation modes)	Default setting	6548	Restart power?	Yes
--------------	--	-----------------	------	----------------	-----

Pn50C	Input signal selection 3 (All operation modes)	Default setting	8888	Restart power?	Yes
--------------	--	-----------------	------	----------------	-----

Pn50d	Input signal selection 4 (All operation modes)	Default setting	8888	Restart power?	Yes
--------------	--	-----------------	------	----------------	-----

Pn50E	Output signal selection 1 (All operation modes)	Default setting	3211	Restart power?	Yes
--------------	---	-----------------	------	----------------	-----

Pn50F	Output signal selection 2 (All operation modes)	Default setting	0000	Restart power?	Yes
--------------	---	-----------------	------	----------------	-----

Pn510	Output signal selection 3 (All operation modes)			Default setting	0000	Restart power?	Yes
--------------	---	--	--	-----------------	------	----------------	-----

Pn512	Output signal reverse (All operation modes)			Default setting	0000	Restart power?	Yes
--------------	---	--	--	-----------------	------	----------------	-----

Note Refer to 4-4-3 Important Parameters.

Pn511	Not used.						
Setting range	---	Unit	---	Default setting	8888	Restart power?	No

Note Do not change the setting.

Pn513	Input signal selection 6 (All operation modes)			Default setting	0088	Restart power?	Yes
--------------	--	--	--	-----------------	------	----------------	-----

Note Refer to 4-4-3 Important Parameters.

Pn51A	Motor-load deviation over level (Option)						
Setting range	0 to 32767	Unit	Command unit	Default setting	0	Restart power?	No

- Set this parameter when a DeviceNet Option Unit (R88A-NCW152-DRT) is mounted and a fully-closed encoder will be used.
- This parameter is valid whenever Pn002.3 (Fully-closed encoder usage method) is not set to 0.
- Set the allowable error level in command units for a fully-closed encoder or semi-closed encoder (i.e., the encoder mounted on a W-series Servomotor).
- If the position error of the fully-closed encoder or semi-closed encoder exceeds the value set for this parameter, an A.d1 alarm (Motor-load deviation over) will be detected.
- If this parameter is set to 0, an A.d1 alarm will not be detected. Set it to 0 in systems where there is slipping between drive (i.e., motor) and the detection device (i.e., fully-closed encoder).
- Do not change the default setting when using a Servo Driver alone without a DeviceNet Option Unit or when not using a fully-closed encoder.

Note Refer to the *OMNUC W-series DeviceNet Option Unit User's Manual (I538)* for details on application methods for a fully-closed encoder (fully-closed loop control).

Pn51b	Not used.						
Setting range	---	Unit	---	Default setting	100	Restart power?	No

Note 1. Do not change the setting.

Note 2. This new parameter is supported by Servo Drivers with software version "r.0037."

Pn51C	Not used.						
Setting range	---	Unit	---	Default setting	450	Restart power?	No

Note 1. Do not change the setting.

Note 2. This new parameter is supported by Servo Drivers with software version "r.0037."

Pn51E	Deviation counter overflow warning level (Position)						
Setting range	0 to 100	Unit	%	Default setting	0	Restart power?	No

- Set the deviation counter overflow warning detection level using the ratio (%) for Pn505 (deviation counter overflow level).
- When the deviation counter residual pulses exceed the set value, a deviation counter overflow warning (A.90) will occur.
- When the set value is 0, the deviation counter overflow warning will not be detected.

Note This new parameter is supported by Servo Drivers with software version “r.0037.”

■ Other Parameters (From Pn600)

Pn600	Regeneration resistor capacity						
Setting range	0 to Unit type	Unit	x 10 W	Default setting	0	Restart power?	No

- If using an External Regeneration Resistor or External Regeneration Resistance Unit, set the regeneration absorption amount. Set the regeneration absorption amount for when the temperature rises above 120°C, not the nominal amount. (Refer to *Regenerative Energy Absorption Using External Regeneration Resistance* for details.)
- Perform Un00A (regeneration load monitor) calculations, and A.92 (regeneration overload warning) and A.32 (regeneration overload alarm) based on the Pn600 setting.

Note If an External Regeneration Resistor or External Regeneration Resistance Unit is not connected, set Pn600 to 0.

Pn601	Not used.						
Setting range	---	Unit	---	Default setting	0	Restart power?	No

Note Do not change the setting.

4-5 Operation Functions

4-5-1 Position Control (Position)

■ Functions

- Perform position control using the pulse train input from CN1-7,8 for CW and CN1-11,12 for CCW.
- The Servomotor rotates using the value of the pulse train input multiplied by the electronic gear (Pn202, Pn203).

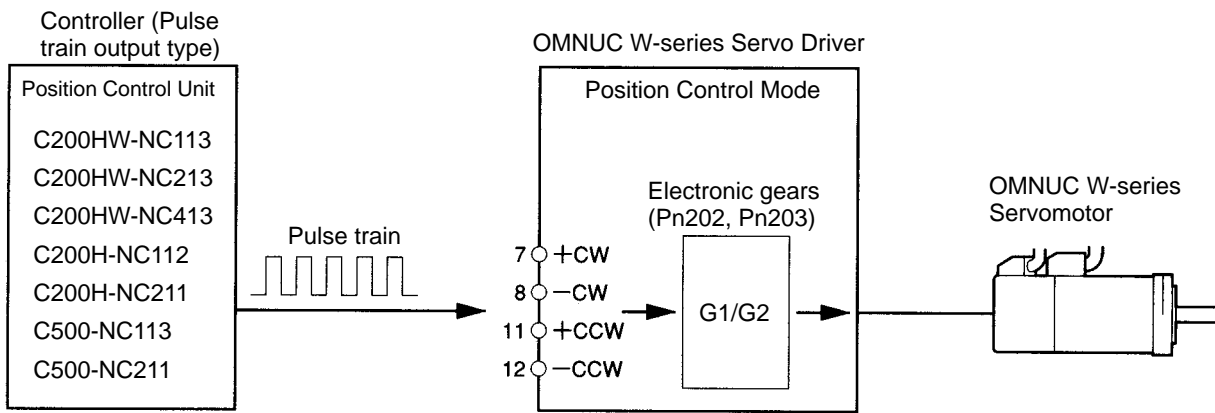

■ Parameters Requiring Settings

Parameter No.	Parameter name	Explanation	Reference
Pn000.1	Function selection basic switch 1 Control mode selection	Select the control mode you wish to use for position control (settings: 1, 5, 7, 8, b).	4-4-3 Important Parameters
Pn200.0	Position control setting 1 Command pulse mode	Set to match the controller command pulse status.	4-4-3 Important Parameters
Pn202	Electronic gear ratio G1 (denominator)	Set the pulse routes for the command pulse and Servomotor travel amount. $0.01 \leq G1/G2 \leq 100$	4-5-12 Electronic Gear Function
Pn203	Electronic gear ratio G2 (numerator)		

■ Related Functions

- The main functions related to position control that can be used during position control are as follows:

Function name	Explanation	Reference
Position command filter function	Sets the soft start for the command pulse.	4-5-13 Position Command Filter Function
Torque feed-forward function	Calculates TREF (torque command input) for the current loop to reduce positioning time.	4-8-3 Torque Feed-Forward Function
Speed feed-forward function	Calculates REF (speed command input) for the current loop to reduce positioning time.	4-8-4 Speed Feed-forward Function
Feed-forward function	Calculates command pulse differential for the speed loop to reduce positioning time.	4-8-2 Feed-forward Function
Bias function	Calculates number of bias rotations for the speed loop to reduce positioning time.	4-8-1 Bias Function
Torque limit function	Limits the Servomotor's torque output.	4-5-10 Torque Limit Function
Gain reduction function	Switches speed loop command from PI control to P control by inputting a MING (gain reduction) signal to lower servo rigidity.	4-5-9 Gain Reduction
P control switching function	Switches the speed control loop automatically from PI control to P control to lower servo rigidity. (Switching conditions can be selected.)	4-8-10 P Control Switching

4-5-2 Speed Control (Speed)

■ Function

- Performs Servomotor speed control using analog voltage input from the speed command (REF: CN1-5, 6). You can also perform position control by combining speed control with the controller mounted to the position control function.
- You can change the relationship between the speed command and the rotation speed by setting the speed command scale (Pn300).

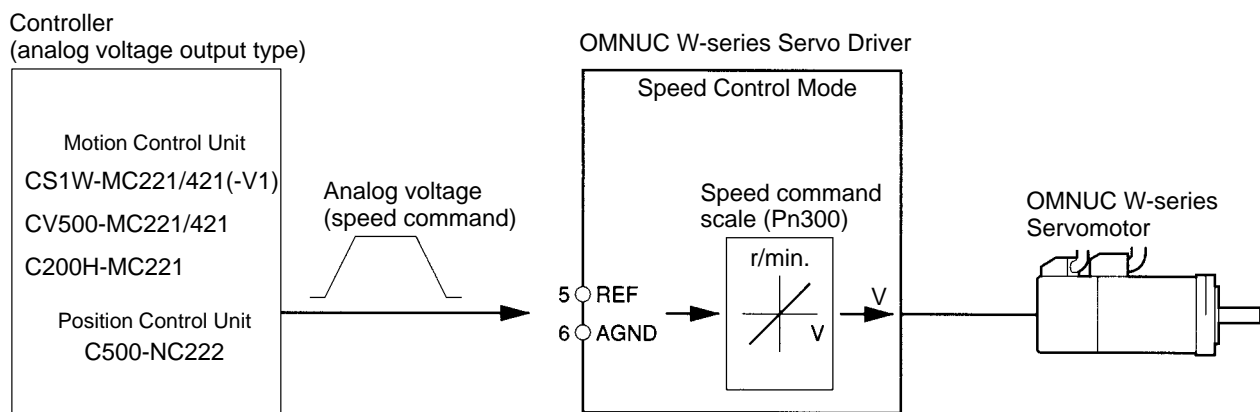

■ Parameters Requiring Settings

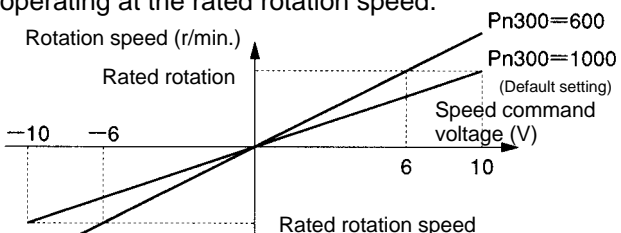
Parameter No.	Parameter name	Explanation	Reference
Pn000.1	Function selection basic switch 1	Set the control mode for speed control (Settings: 0, 4, 7, 9, A)	4-4-3 Important Parameters
Pn300	Speed command scale	Set the REF (speed command input) voltage for operating at the rated rotation speed. 	4-4-4 Parameter Details

■ Related Functions

- The main functions related to speed control that can be used during speed control are as follows:

Function name	Explanation	Reference
Soft start function	Sets the soft start for the speed command.	4-5-11 Soft Start Function
Position lock function	This function stops the Servomotor in servolock status (position control status) using PLOCK (position lock command) signal input.	4-5-14 Position Lock Function
Torque feed-forward function	Calculates TREF (torque command input) for the current loop to reduce acceleration and deceleration time.	4-8-3 Torque Feed-forward Function
Torque limit function	This function limits the Servomotor's output torque output.	4-5-10 Torque Limit Function
Gain reduction function	Switches speed loop command from PI control to P control by inputting a MING (gain reduction) signal to lower servo rigidity.	4-5-9 Gain Reduction
P control switching function	Switches the speed control loop automatically from PI control to P control to lower servo rigidity (you can select the switching conditions).	4-8-10 P Control Switching

4-5-3 Torque Control (Torque)

■ Functions

- Controls the Servomotor output torque using analog voltage input from the torque command (TREF: CN1-9, 10).
- You can change the relationship between the torque command and output torque using the torque control scale (Pn400) setting.

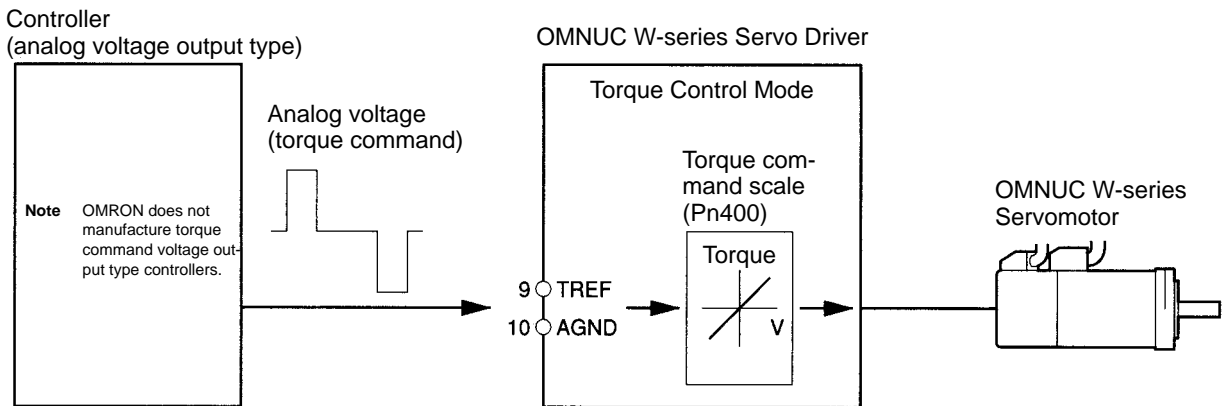

■ Parameters Requiring Settings

Parameter No.	Parameter name	Explanation	Reference
Pn000.1	Function selection basic switch 1	Select the control mode for torque control (Settings: 2, 6, 8, 9)	4-4-3 Important Parameters
Pn400	Torque command scale	Set the TREF (torque command input) voltage to output the rated torque. 	4-4-4 Parameter Details

Note Servomotor operation with torque control varies according to the Servomotor load conditions (e.g., friction, external power, inertia). Perform safety measures on the devices to prevent Servomotor runaway.

■ Related Functions

- Functions related to torque control that can be used during torque control are as follows:

Function name	Explanation	Reference
Torque limit function	This function limits the Servomotor’s torque output.	4-5-10 Torque Limit Function
Speed limit function	This function limits the Servomotor rotation speed from becoming too high.	4-5-15 Speed Limit Function

4-5-4 Internally-set Speed Control

■ Functions

- Controls the Servomotor speed using the speed (internally-set speed Nos. 1 to 3) set in the parameters.
- Selects the internally-set speed using the control input terminal’s speed selection commands 1 and 2 (SPD1: CN1-45, SPD2: CN1-46), and sets the rotation direction using the rotation direction command (RDIR: CN1-41) (Pin No. is the default allocation.)
- When SPD1 and SPD2 are both OFF, the Servomotor decelerates and stops according to the deceleration time. At this time, you can make pulse train inputs (during position control), speed command inputs (during speed control), and torque command inputs (during torque control) using the parameter settings.

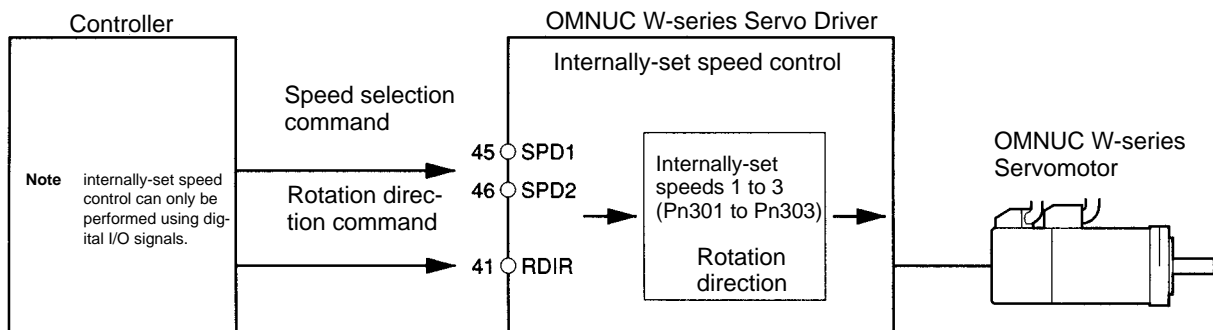

■ Parameters Requiring Settings

Parameter No.	Parameter name	Explanation	Reference
Pn000.1	Function selection basic switch 1 Control mode selection	Select the control mode for the internally-set speed control (Settings: 3, 4, 5, 6)	4-4-3 Important Parameters
Pn50C	Input signal selection 3	You must set Pn50C.0 (RDIR signal selection), Pn50C.1 (SPD1 signal selection), and Pn50C.2 (SPD2 signal selection). (See note 1.)	4-4-3 Important Parameters
Pn301	No. 1 Internal speed setting	Set the internally-set speed (r/min.) (0 to 10,000 r/min.) (See note 2.)	4-4-4 Parameter Details
Pn302	No. 2 internally-set speed		
Pn303	No. 3 internal speed setting		
Pn305	Soft start acceleration time	Set the acceleration and deceleration times (ms) separately (0 to 10,000 ms).	4-8-10 P Control Switching
Pn306	Soft start deceleration time		

Note 1. If changing the default setting, set Pn50A.0 (input signal selection mode) to 1 (user-defined settings).

Note 2. If the maximum Servomotor rotation speed setting is greater than Pn301, Pn302, and Pn303, the setting will be taken to be the maximum rotation speed.

■ Related Functions

- The main functions related to internal speed setting control that can be used during internal speed setting control are as follows:

Function name	Explanation	Reference
Position lock function	This function stops the Servomotor in servolock status (position control status) using PLOCK (position lock command) signal input.	4-5-14 Position Lock Function
Torque limit function	This function limits the torque output by the Servomotor.	4-5-10 Torque Limit Function
Gain reduction function	Switches speed loop command from PI control to P control by inputting a MING (gain reduction) signal to lower servo rigidity.	4-5-9 Gain Reduction
P control switching function	Switches the speed control loop automatically from PI control to P control to lower servo rigidity. (The switching conditions can be selected.)	4-8-10 P Control Switching

■ Internally-set Speed Selection

- The following table shows the relationship between SPD1 and SPD2 (speed selection commands 1 and 2), and the internally-set speeds that are selected.

Control mode setting	TVSEL	SPD1: OFF		SPD1: ON	
		SPD2: OFF	SPD2: ON	SPD2: OFF	SPD2: ON
Pn000.1 = 3 Internally-set speed control	---	Stop by speed loop.	No. 1 internal speed setting (Pn301)	No. 3 internal speed setting (Pn303)	No. 2 internal speed setting (Pn302)
Pn000.1 = 4 Internally-set speed control ↔ Speed control	TVSEL: OFF	Stop by speed loop.	No. 1 internal speed setting (Pn301)	No. 3 internal speed setting (Pn303)	No. 2 internal speed setting (Pn302)
	Pn50A.0 = 0 (See note 1.)				
	TVSEL: ON		Speed control		
Pn000.1 = 5 Internally-set speed control ↔ Position control	TVSEL: OFF	Stop by speed loop.	No. 1 internal speed setting (Pn301)	No. 3 internal speed setting (Pn303)	No. 2 internal speed setting (Pn302)
	Pn50A.0 = 0 (See note 1.)				
	TVSEL: ON		Position control		
Pn000.1 = 6 Internally-set speed control ↔ Torque control	TVSEL: OFF	Stop by speed loop.	No. 1 internal speed setting (Pn301)	No. 3 internal speed setting (Pn303)	No. 2 internal speed setting (Pn302)
	Pn50A.0 = 0 (See note 1.)				
	TVSEL: ON		Torque control		

Note 1. When Pn50A.0 (input signal allocation mode) is set to the default setting (0) and Pn000.1 is set between 4 and 6, the control mode switches without TVSEL (control mode switching) signal allocation or input.

Note 2. When Pn50A.0 is set to 1 and the TVSEL signal is allocated, the control mode switches according to the TVSEL signal.

■ Operation Examples

• Internally-set Speed Control Settings Only (Pn000.1 = 3)

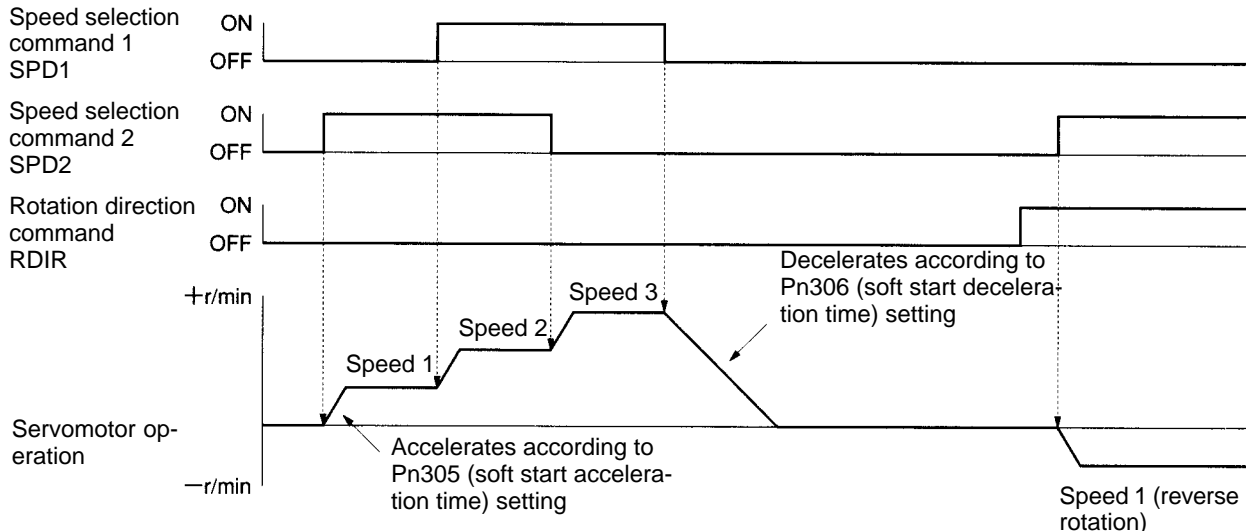

Note 1. There is a maximum delay of 2 ms in reading the input signal.

Note 2. If the position lock function is not used, the servo will stop using the speed loop (i.e., internal speed command 0 r/min.)

Note 3. Speed command input, pulse train input, and torque command input are ignored.

● **Internally-set Speed Control + Speed Control (Pn000.1 = 4)**

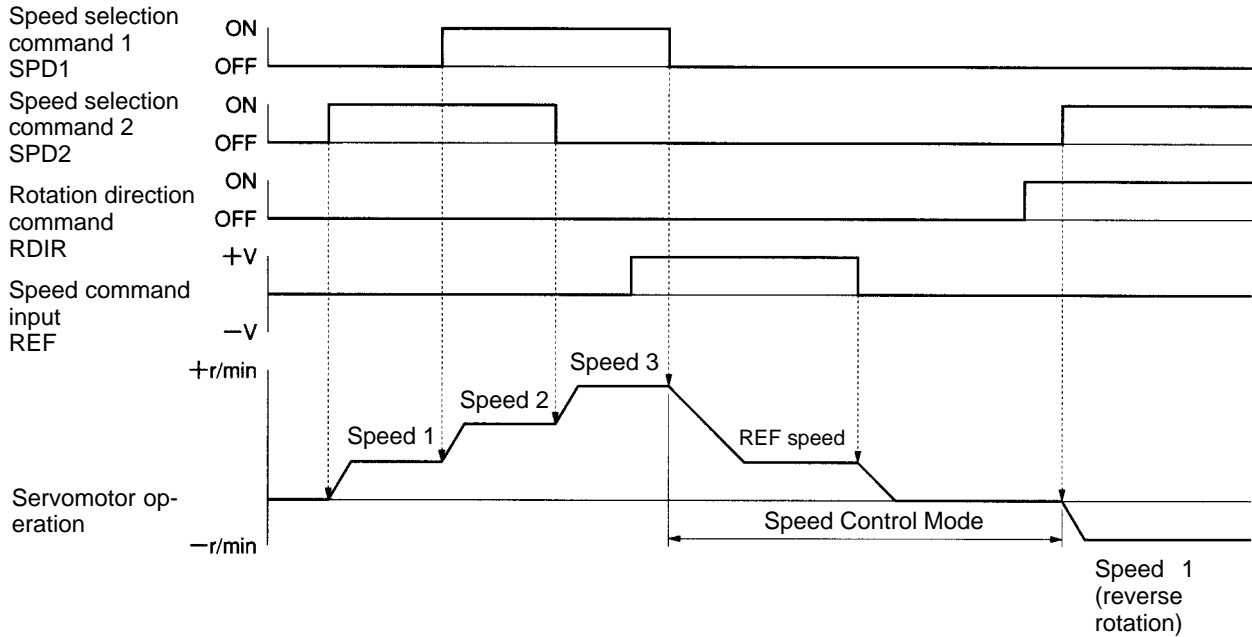

Note Operation follows the speed command input (REF) immediately after SPD1 and SPD2 are both OFF (although there is a delay of up to 2 ms in reading the input signal).

● **Internally-set Speed Control + Position Control (Pn000.1 = 5)**

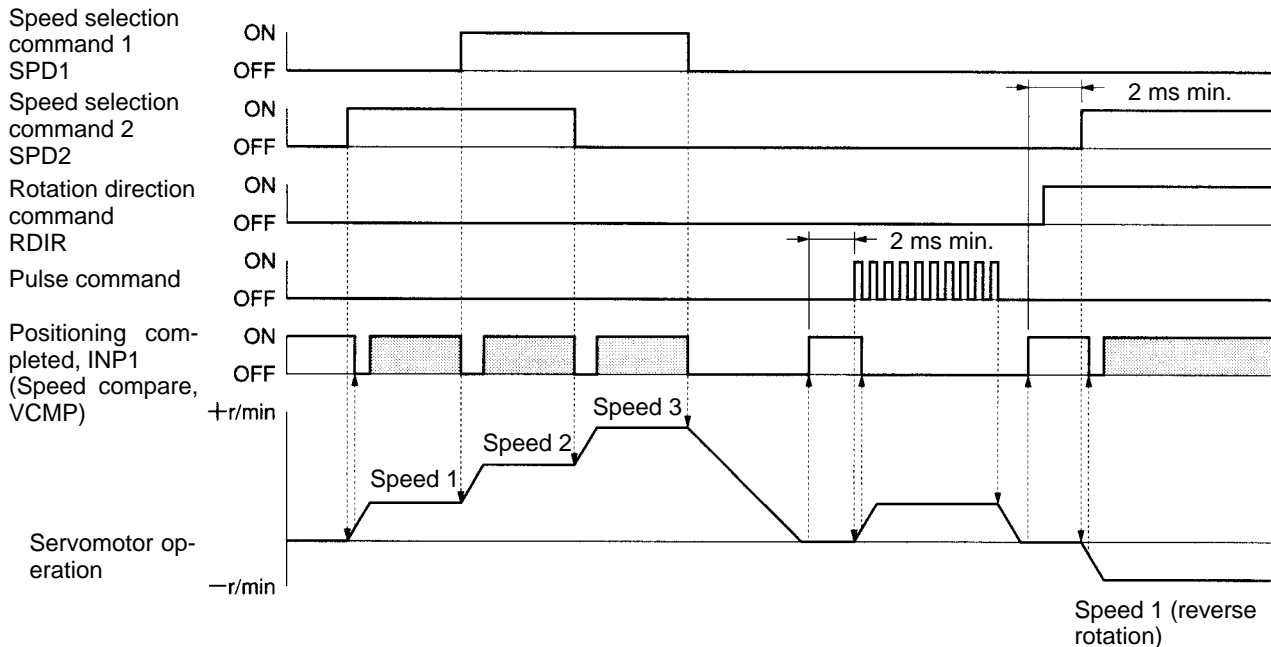

Note 1. When SPD1 and SPD2 are turned OFF, the Servomotor will decelerate to a stop, INP1 (position completed output 1) will be output, and the servo will be position-locked. Pulse train com-

mand inputs can be received in this status. The pulse command is input after INP1 is turned ON. Until INP1 is turned ON, pulse inputs are ignored.

Note 2. After INP1 has turned ON, turn ON the speed selection command in the same way as when switching from position control to internally-set speed control.

Note 3. There is a maximum delay of 2 ms in reading the input signal.

Note 4. The shaded areas in the time chart for the positioning completed signal (INP1) indicate the places where the signal is turned ON as the VCMP (speed compare) signal. (The meaning of the signal differs according to the control mode.)

● Internally-set Speed Control + Torque Control (Pn000.1 = 6)

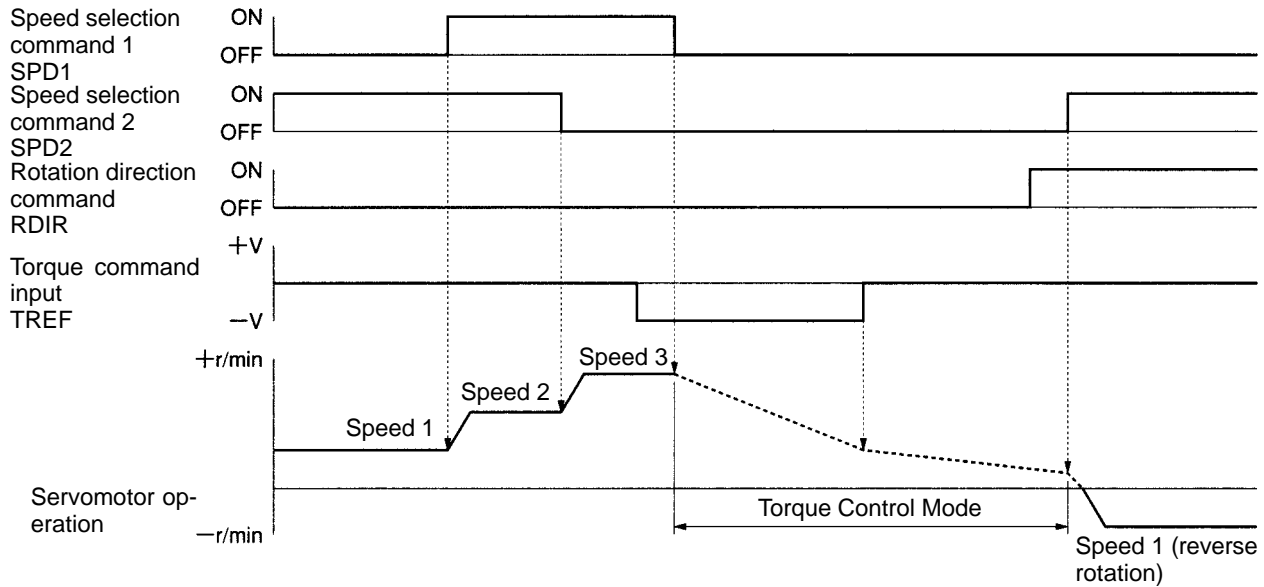

Note 1. Operation follows the speed command input (TREF) immediately after SPD1 and SPD2 are both OFF (although there is a delay of up to 2 ms in reading the input signal).

Note 2. Servomotor operation with torque control varies according to the Servomotor load conditions (e.g., friction, external power, inertia). Perform safety measures on the devices to prevent Servomotor runaway.

Note 3. When Servomotor servo-lock is required, set any of the internal speed settings to 0 r/min and select that speed with SPD1 and SPD2 (speed selection commands 1 and 2).

4-5-5 Switching the Control Mode (Switching Control)

■ Functions

- This function controls the Servomotor by switching between two control modes by means of external inputs.
- The control mode switching is executed at the control mode switching control input terminal (TVSEL: CN1-41).

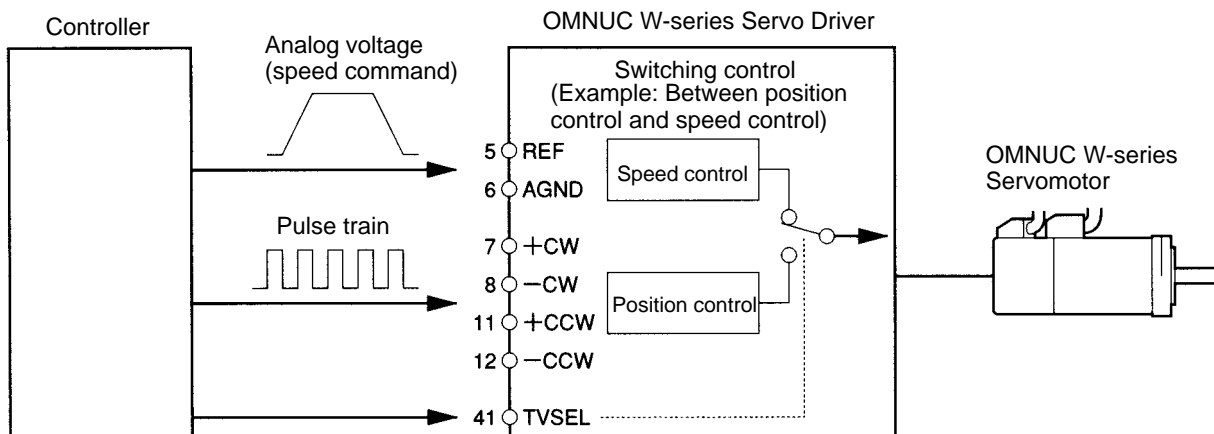

■ Parameters Requiring Settings

Parameter No.	Parameter name	Explanation	Reference
Pn000.1	Function selection basic switch 1 Control mode selection	Select control mode for switching control (Settings: 7, 8, 9)	4-4-3 Important Parameters
Pn50C.3	Input signal selection 3 TVSEL signal selection	You must set Pn50C.3 (TVSEL signal selection). (See note.)	4-4-3 Important Parameters

Note If you select the switching control mode with the default settings, the mode will be allocated to pin CN1-41.
If changing the default setting, set Pn50A.0 (input signal selection mode) to 1 (user-defined settings).

■ Related Functions

Note Refer to the related functions for each control mode.

■ Control Mode Selected Using TVSEL (Control Mode Switching)

- The following table shows the relationship between TVSEL (control mode switching) and the control mode selected.

Control mode setting	TVSEL	
	OFF	ON
Pn000.1 = 4 (between internally-set speed control and speed control)	Internally-set speed control	Speed control
Pn000.1 = 5 (between internally-set speed control and position control)	Internally-set speed control	Position control
Pn000.1 = 6 (between internally-set speed control and torque control)	Internally-set speed control	Torque control
Pn000.1 = 7 (between position control and speed control)	Position control	Speed control
Pn000.1 = 8 (between position control and torque control)	Position control	Torque control
Pn000.1 = 9 (between torque control and speed control)	Torque control	Speed control

Note 1. When Pn50A.0 (input signal allocation mode) is set to the default setting (0) and Pn000.1 is set between 4 and 6, the control mode switches without TVSEL (control mode switching) signal allocation or input.

Note 2. When Pn50A.0 is set to 1, with Pn000.1 set between 4 and 6, and the TVSEL signal is allocated, the control mode switches according to the TVSEL signal.

Note 3. For details on internally-set speed control, refer to 4-5-4 Internally-set Speed Control.

■ Operation Examples

● Position and Speed Control Switching Example (Pn000.1 = 7)

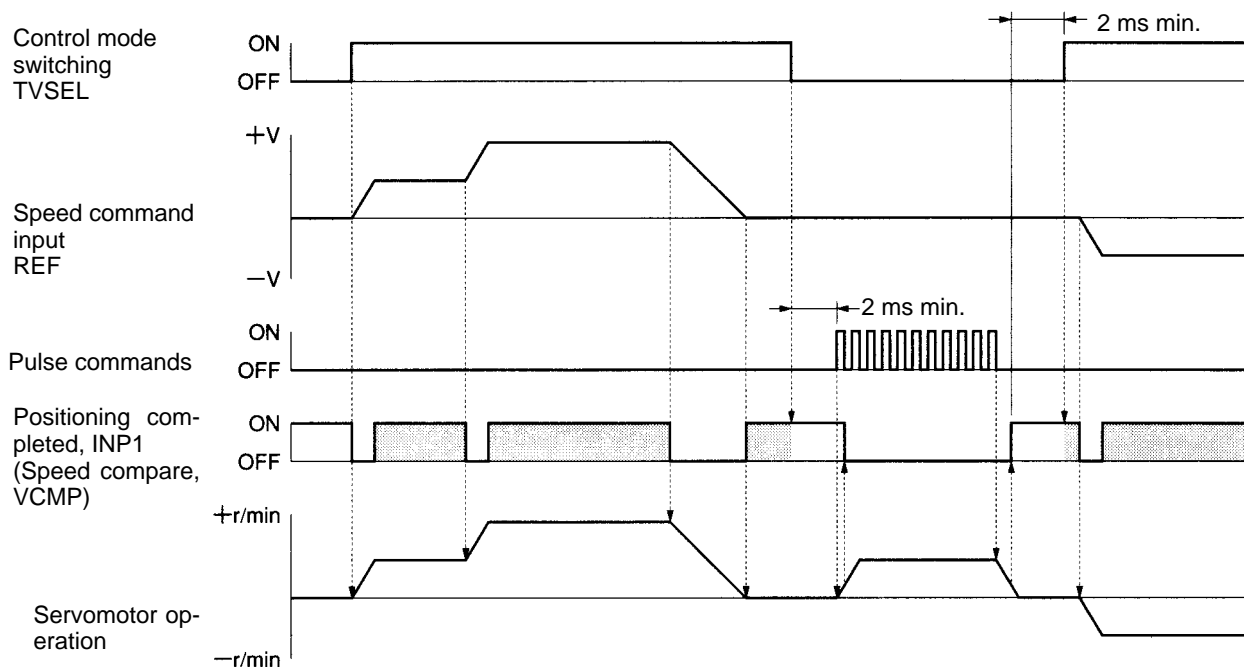

- Note 1.** There is a maximum delay of 2 ms in reading the input signal.
- Note 2.** When switching from speed control to position control, input the pulse command after TVSEL (control mode switching) has turned OFF, INP1 (positioning completed output 1) signal has turned ON, and 2 ms has elapsed. The pulses will be ignored until the positioning completed (INP1) signal has turned ON.
- Note 3.** The shaded areas in the time chart for the positioning completed 1 (INP1) signal indicate the places where the signal is turned ON as the VCMP (speed compare) signal. (The meaning of the signal differs according to the control mode.)

● Position and Torque Control Switching Example (Pn000.1 = 8)

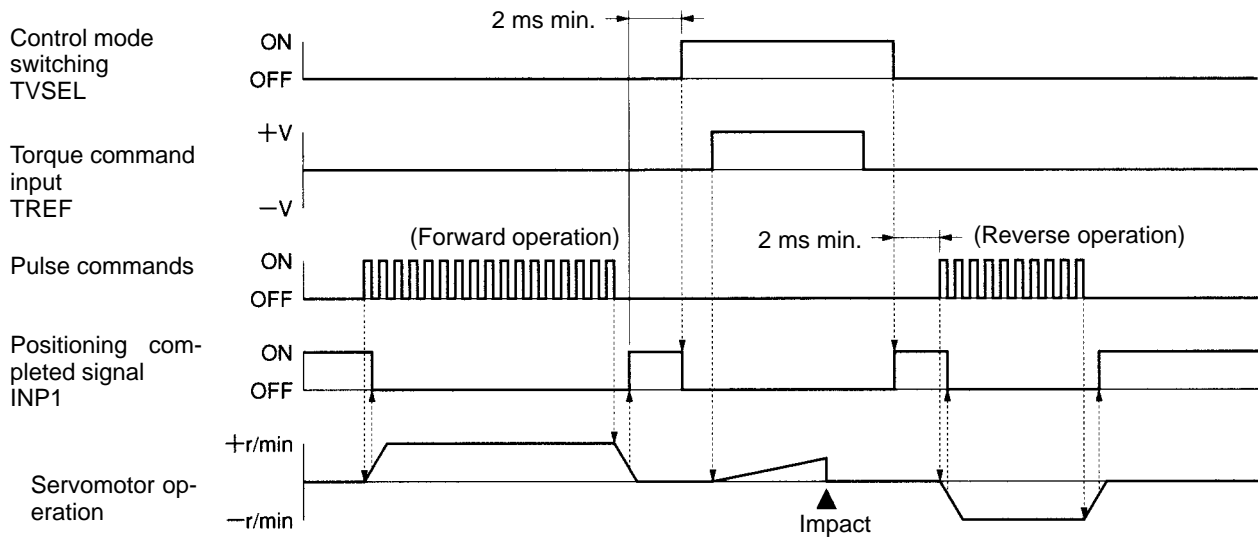

- Note 1.** This time chart shows an example of torque thrust.
- Note 2.** There is a maximum delay of 2 ms in reading the input signal.
- Note 3.** When switching from torque control to position control, input the pulse command after TVSEL (control mode switching) has turned OFF, the positioning completed output 1 (INP1) signal has turned ON, and 2 ms has elapsed. The pulses will be ignored until the positioning completed output 1 (INP1) signal has turned ON.

● Speed and Torque Control Switching Example (Pn000.1 = 9)

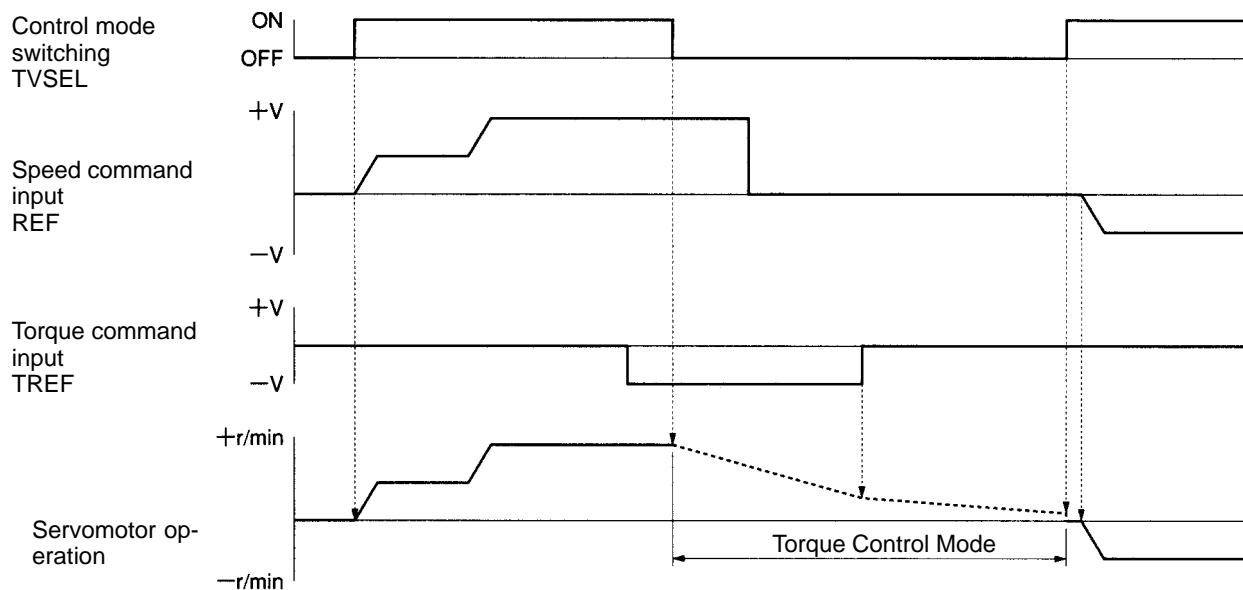

Note 1. There is a maximum delay of 2 ms in reading the input signal.

Note 2. Servomotor operation with torque control varies according to the Servomotor load conditions (e.g., friction, external power, inertia). Perform safety measures on the devices to prevent the Servomotor from running amok.

4-5-6 Forward and Reverse Drive Prohibit (All Operating Modes)

■ Functions

- When forward drive prohibit (POT: CN1-42) and reverse drive prohibit (NOT: CN1-43) are OFF, stops the Servomotor rotating (Pin No. is allocated in the default settings).
- You can stop the Servomotor from rotating beyond the device’s travel range by connecting a lit input.

■ Parameters Requiring Setting

Parameter No.	Parameter name	Explanation	Reference
Pn50A.3 Pn50b.0	Input signal selection 1: POT signal selection Input signal selection 2: NOT signal selection	You must allocate both POT and NOT. (See note.)	4-4-3 Important Parameters
Pn001	Function selection switch 1	Set the stop method when POT and NOT in Pn001.1 (stop selection for drive prohibition input) are OFF. If Pn001.1 is set to 0 (stop according to Pn001.0 setting), be sure to set Pn001.0 (stop selection for alarm generation with servo OFF).	4-4-3 Important Parameters
Pn406	Emergency stop torque	If Pn001.1 is set to 1 or 2, set emergency stop torque in Pn406.	4-4-4 Parameter Details

Note POT and NOT are allocated to CN1-42, 43 in the default settings, but are both set to disabled (i.e., drive prohibition will not operate). If changing the default setting, set Pn50A.0 (input signal selection mode) to 1 (user-defined settings).

■ Operation

Stopping Methods when Forward/Reverse Drive Prohibit is OFF

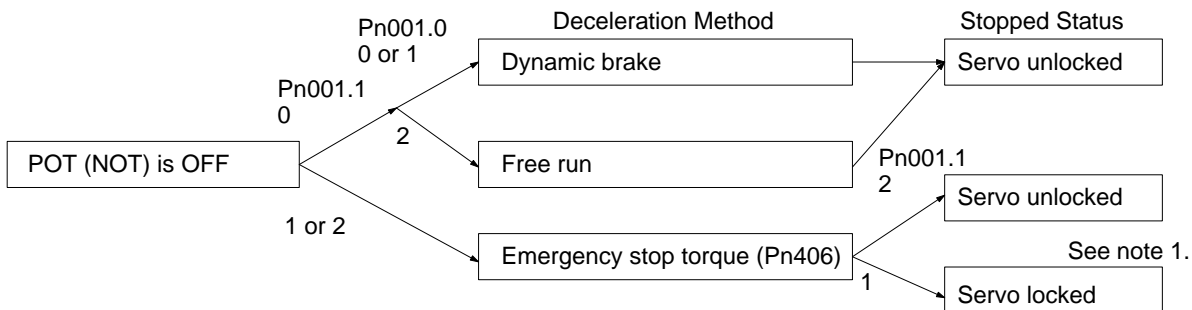

- Note 1.** If the Servomotor stops in this mode during position control, the position loop is disabled.
- Note 2.** The position method used during torque control depends on Pn001.0 setting (the P001.1 setting is unrelated).
- Note 3.** With a vertical load, the load may fall due to its own weight if it is left at a drive prohibit input. We recommend that you set the stop method for the drive prohibit input (Pn001.1) for decelerating with the emergency stop torque, and then set stopping with the servo locked (SV: 1) to prevent the load from falling.

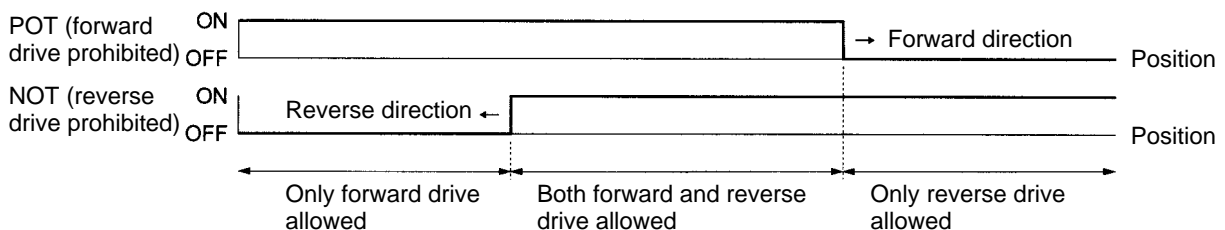

- Note 1.** When a command to travel in a prohibited direction within the drive prohibit area is input, the Servomotor is stopped using the method set in Pn001.1. If a command to travel in the opposite direction is input, the Servomotor automatically resumes operation.
- Note 2.** With position control, the feedback pulses and command pulses continue to be counted without the deviation counter's residual pulses being reset. If the drive prohibit input turns ON in this state (i.e., drive permitted), the position will be shifted by the amount of the residual pulses.

4-5-7 Encoder Dividing Function (All Operating Modes)

■ Function

- With this function, any number of pulses can be set for encoder signals output from the Servo Driver.
- The number of pulses per Servomotor revolution can be set within a range of 16 to (number of encoder resolution pulses). The upper limit is 16,384 pulses/rotation.
- Use this function for the following applications:
 When using a controller with a low response frequency.
 When it is desirable to set a pulse rate that is easily divisible.
 (For example, in a mechanical system in which a single Servomotor revolution corresponds to a travel of 10 mm, if the resolution is 5 μm/pulse, set the encoder dividing rate to 2,000 (pulses/revolution).

■ Parameters Requiring Setting

Parameter No.	Parameter name	Explanation	Reference
Pn201	Encoder dividing rate setting	Set the number of encoder pulses to be output. (See notes 1, 2, and 3).	4-4-4 Parameter Details

- Note 1.** The default setting is 1,000 (pulses/rotation), and the setting range is 16 to 16,384 (pulses/rotation).
- Note 2.** These parameters are enabled when the power is turned ON again after having been turned OFF. (Check to see that the LED display has gone OFF.)
- Note 3.** If a value greater than the encoder resolution is set, operation will proceed according to the formula: (dividing rate setting) = (encoder resolution)

■ Operation

- Incremental pulses are output from the Servo Driver through a frequency divider.

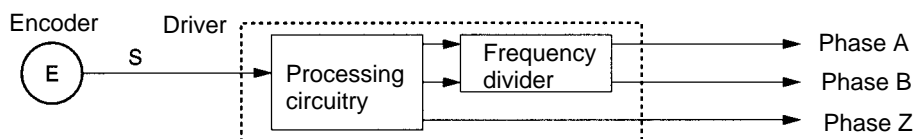

- The output phases of the encoder signal output from the Servo Driver are as shown below (when divider ratio Pn201 = encoder resolution).

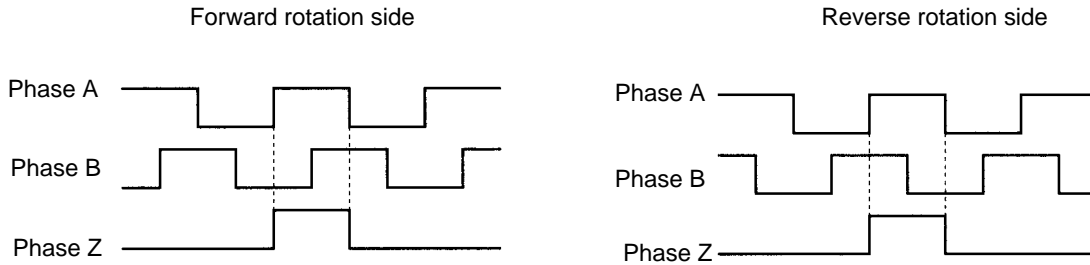

- When the encoder divider rate is set to other than 2^n (16,384, 8,192, 4,096, 2,048, 1,024, etc.), the phase difference for phases A and B is not 90° , but scatters for time T. (See the diagram below.)

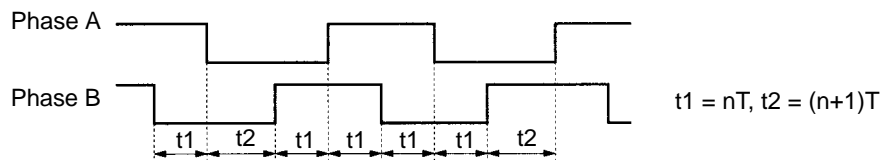

In this diagram, T represents the processing circuit output between phase A and phase B, and n is an integer that satisfies the following formula (with digits below the decimal point discarded).

$$n = \text{resolution}/\text{encoder divider rate}$$

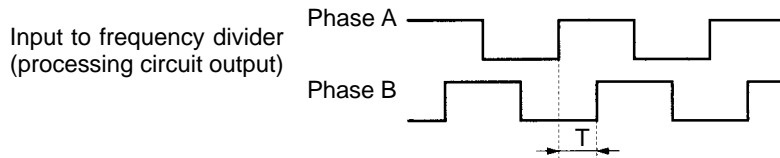

4-5-8 Brake Interlock (All Operating Modes)

■ Precautions for Using Electromagnetic Brake

- The electromagnetic brake Servomotor with a brake is a non-excitation brake especially for holding. First stop the Servomotor, then turn OFF the power supply to the brake before setting the parameters. If the brake is applied while the Servomotor is operating, the brake disk may become damaged or malfunction due to friction, causing damage to the Servomotor.

■ Function

- You can set the BKIR (brake interlock) signal output timing to turn ON and OFF the electromagnetic brake.

■ Parameters Requiring Setting

Parameter No.	Parameter name	Explanation	Reference
Pn50F.2	Output signal selection 2: BKIR signal selection	Be sure to allocate BKIR. (See note.)	4-4-3 Important Parameters
Pn506	Brake timing 1	This parameter sets the BKIR output timing.	4-4-4 Parameter Details
Pn507	Brake command speed	Pn506: Sets lag time from BKIR OFF to servo OFF. Pn507: Sets the rotation speed for turning BKIR OFF.	
Pn508	Brake timing 2	Pn508: Sets the standby time from servo OFF to BKIR OFF.	

Note BKIR is not allocated in the default settings.

■ Operation

● RUN Timing (When Servomotor Is Stopped)

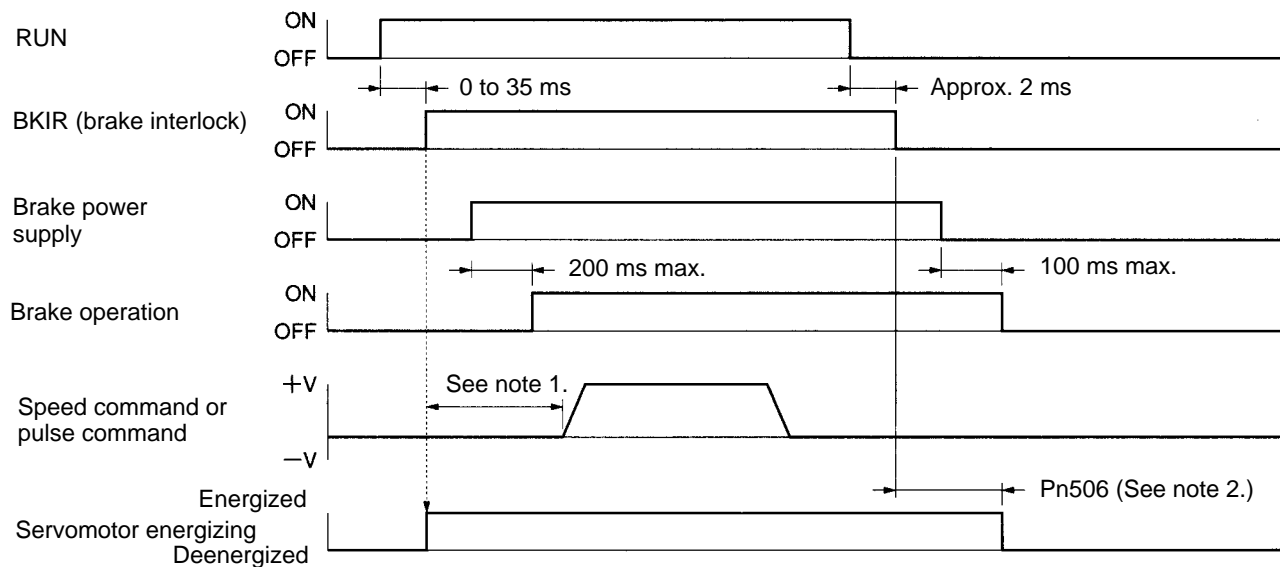

Note 1. The time from turning ON the brake power supply to the brake being released is 200 ms max. Set the speed command (pulse command) to be given after the brake has been released, taking this delay into account.

Note 2. The time from turning OFF the brake power supply to the brake engaging is 100 ms max. If using the Servomotor on a vertical axis, set Pn506 (brake timing 1) so that the Servomotor deenergizes after the brake has engaged, taking this delay into account.

● Power Supply Timing (When Servomotor is Stopped)

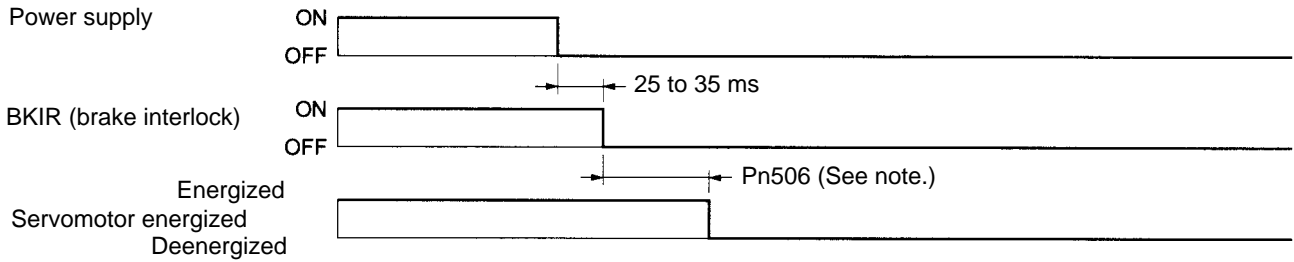

Note The time from turning OFF the brake power supply to the brake engaging is 100 ms max. If using the Servomotor on a vertical axis, set Pn506 (brake timing 1) so that the Servomotor deenergizes after the brake has engaged, in consideration of this delay.

● RUN, Error, and Power Supply Timing (When Servomotor Is Stopped)

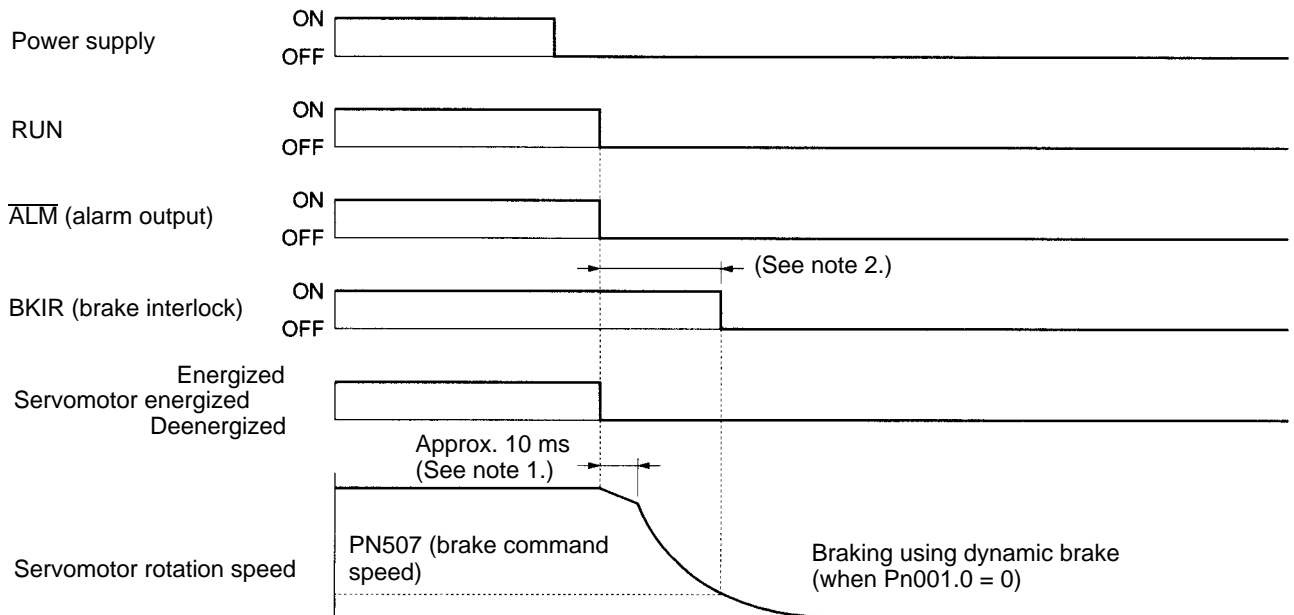

Note 1. During the approximately 10 ms from the Servomotor deenergizing to dynamic brake being applied, the Servomotor will continue to rotate due to its momentum.

Note 2. If the Servomotor rotation speed falls below the speed set in Pn507 (brake command speed) or the time set in Pn508 (brake timing 2) after the Servomotor deenergizes is exceeded, the BKIR (brake interlock) signal is turned OFF.

4-5-9 Gain Reduction (Position, Speed, Internally-set speed Control)

■ Functions

- This function switches speed loop control from PI (proportional integration) control to P (proportional) control when gain reduction (MING: CN1-41) is ON. (Pin No. is allocated in the default settings.)
- The speed loop gain is lowered when the proportional gain is lost. Also, resiliency to the external load force is reduced by the speed error proportion (difference between the speed command and speed feedback) being lost.

- If controlling the position without adding a position control loop, the position may slip due to temperature drift from the A/D converter, etc. In this case, when MING (gain reduction) is input, the speed loop gain will fall, and the amount of drift will be lowered. If there is static friction on the load (5% min. of the rated torque), the Servomotor may stop completely.
- Inputting MING during parts insertion operations after positioning is completed with a position loop incorporated will make parts insertion easier by weakening resistance to external force.
- This is also effective for operating at high gain during rotations, and for lowering gain to suppress vibrations when the Servomotor is stopped.

Note If MING is input with applications that include vertical axes with gravity loads or continuous external force, the target position cannot be attained.

■ Parameters Requiring Setting

Parameter No.	Parameter name	Explanation	Reference
Pn50A.2	Input signal selection 1: MING signal selection	Be sure to allocate MING. (See note.)	4-4-3 Important Parameters

Note If changing the default setting, set Pn50A.0 (input signal selection mode) to 1 (user-defined settings).

4-5-10 Torque Limit Function (All Operating Modes)

■ Functions

- The torque limit function limits the Servomotor’s output torque.
- This function can be used to protect the Servomotor and mechanical system by preventing excessive force or torque on the mechanical system when the machine (moving part) pushes against the workpiece with a steady force, such as in a bending machine.
- There are four methods that can be used to limit the torque (pin No. is allocated at the factory):
 - Limit the steady force applied during normal operation with user parameters Pn402 (forward torque limit) and Pn403 (reverse torque limit). (All operation modes.)
 - Limit operation with external signals connected to pins CN1-45 (PCL: forward current limit input) and CN1-46 (NCL: reverse current limit input). Set user parameters Pn404 (forward rotation external current limit) and Pn405 (reverse rotation external current limit) (all operation modes).
 - Limit normal operation with analog voltage using TREF (torque command input) as the analog current limit input (position, speed, internally-set speed limit).
 - Limit analog voltage with external signals connected to pins CN1-45 (PCL: forward current limit input) and CN1-46 (NCL: reverse current limit input) using TREF (position, speed, internally-set speed limit).
- When torque limit is ON, CLIMT (current limit detection) signal is output (if the signal has been allocated using parameter Pn50F.0).
- If multiple torque limits are enabled, the output torque is limited to the minimum limit value.

■ Parameters Requiring Settings

● Limiting the Steady Force Applied During Normal Operation with User Parameters (All Operating Modes)

Parameter No.	Parameter name	Explanation	Reference
Pn402	Forward torque limit	Set the output torque limit for the forward direction as a percentage of the rated torque (setting range: 0% to 800%).	4-4-4 <i>Parameter Details</i>
Pn403	Reverse torque limit	Set the output torque limit for the reverse direction as a percentage of the rated torque (setting range: 0% to 800%).	

Note 1. Set these parameters to 350 (the default setting) when the torque limit function is not being used.

Note 2. If the connected Servomotor is set to a value greater than the maximum momentary torque, the maximum momentary torque will become the set limit.

● Limiting Operation with External Signals (All Operating Modes)

Parameter No.	Parameter name	Explanation	Reference
Pn50b.2 Pn50b.3	Input signal selection 2 PCL signal selection NCL signal selection	You must allocate PCL and NCL. (See note 1.)	4-4-3 <i>Important Parameters</i>
Pn404	Forward torque limit	Set the output torque limit when PCL is ON as a percentage of the Servomotor rated torque (setting range: 0% to 800%).	4-4-4 <i>Parameter Details</i>
Pn405	Reverse torque limit	Set the output torque limit when NCL is ON as a percentage of the Servomotor rated torque (setting range: 0% to 800%).	

Note 1. If you change the default settings, set Pn50A.0 (input signal selection mode) to 1.

Note 2. If the connected Servomotor is set to a value greater than the maximum momentary torque, the maximum momentary torque will become the set limit.

Note 3. If using this function with internally-set speed control, set Pn50A.1 to 1 (user-defined settings), and allocate the required input signals (PCL, NCL, SPD1, SPD2, RDIR, etc.)

● Limiting Normal Operation with Analog Voltage (Position, Speed, Internally-set Speed Control)

- When Pn002.0 (torque command input switching) is set to 1, TREF (torque command input) becomes the analog torque limit input terminal, so you can limit the torque on multiple levels.
- Calculate the torque limit (%) as follows: Absolute TREF voltage (V) / Pn400 (torque control scale) x 1000.
- Regardless of whether the voltage is positive or negative, both forward and reverse directions have the same limits (i.e., absolute value is taken).

Parameter No.	Parameter name	Explanation	Reference
Pn002.0	Torque command input switching	Set Pn002.0 to 1. (Use TREF as analog torque limit.)	4-4-4 Parameter Details
Pn400	Torque control scale	Set TREF voltage when using rated torque. (See note.)	

Note The default setting is 30 (x 0.1 V/rated torque).

● **Limiting Analog Voltage with External Signals (Position, Speed, Internally-set Speed Control)**

- If Pn002.0 (torque command input switching) is set to 3, when PCL and NCL are ON, TREF (torque command input) becomes the analog torque limit input terminal.
- Calculate the torque limit (%) as follows:
Absolute TREF voltage (V) / Pn400 (torque control scale) x 1000.
- Regardless of whether the voltage is positive or negative, both forward and reverse directions have the same limits (taken as absolute values).

Parameter No.	Parameter name	Explanation	Reference
Pn002.0	Torque command input switching	Set Pn002.0 to 3 (use TREF as analog torque limit when PCL and NCL are ON).	4-4-4 Parameter Details
Pn50b.2 Pn50b.3	Input signal selection 2 PCL signal selection NCL signal selection	You must allocate PCL and NCL. (See note 1.)	4-4-3 Important Parameters
Pn400	Torque control scale	Set TREF voltage for when the rated torque is used. (See note 2.)	4-4-4 Parameter Details

Note 1. If changing the default setting, set Pn50A.0 (input signal selection mode) to 1 (user-defined settings).

Note 2. The default setting is 30 (x 0.1 V/rated torque).

Note 3. If using this function with internally-set speed control, set Pn50A.1 to 1 (user-defined settings), and allocate the required input signals (PCL, NCL, SPD1, SPD2, RDIR, etc.).

4-5-11 Soft Start Function (Speed, Internally-set Speed Control)

■ **Functions**

- This function accelerates and decelerates the Servomotor in the set acceleration and deceleration times.
- You can set the acceleration and deceleration independently of each other using the trapezoidal acceleration and deceleration curve.
- The soft start processes REF (speed command input) or internally-set speed control switching to reduce shock during acceleration and deceleration.
- This function is effective for simple positioning and speed switching operations.

Note Do not use this function for a position controller with an acceleration/deceleration function.

■ Parameters Requiring Settings

Parameter No.	Parameter name	Explanation	Reference
Pn305	Soft start acceleration time	Set the acceleration time from 0 (r/min.) to the maximum rotation speed (setting range: 0 to 10,000 (ms)).	4-4-4 Parameter Details
Pn306	Soft start deceleration time	Set the deceleration time from maximum rotation speed to 0 (r/min.) Setting range: 0 to 10,000 (ms).	

Note 1. If not using the soft start function, set this parameter to 0 (default setting).

Note 2. The actual acceleration and deceleration time is as follows:

$$\text{Actual acceleration (deceleration time)} = \frac{\text{speed command (r/min.)}}{\text{maximum No. rotations (r/min.)}} \times \text{soft start acceleration (deceleration) time}$$

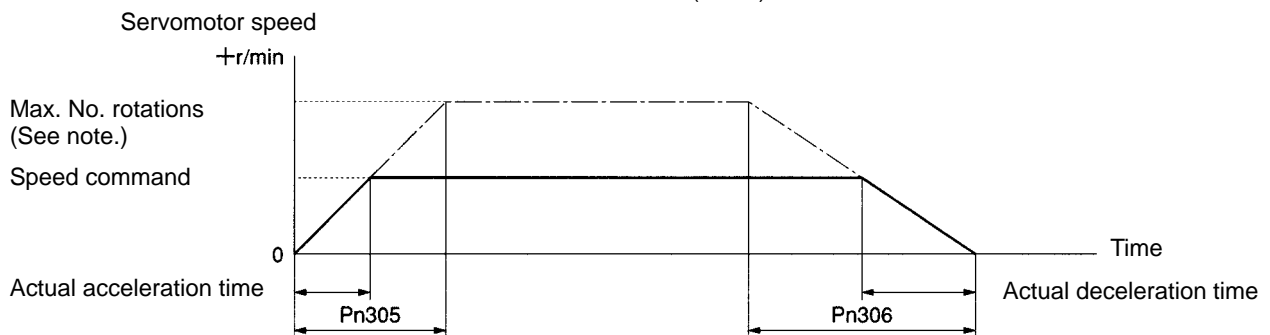

Note The maximum rotation speeds are as follows:

- 3,000-r/min. Servomotor: 5,000 r/min.
- 3,000-r/min. Flat-style Servomotor: 5,000 r/min.
- 1,000-r/min. Servomotor: 2,000 r/min.
- 1,500-r/min. Servomotor (450 W to 7.5 kW): 3,000 r/min.
- 1,500-r/min. Servomotor (11 to 15 kW): 2,000 r/min.

4-5-12 Electronic Gear Function (Position)

■ Functions

- This function rotates the Servomotor for the number of pulses obtained by multiplying the command pulses by the electronic gear ratio.
- This function is enabled under the following conditions.
 - When fine-tuning the position and speed of two lines that are to be synchronous.
 - When using a position controller with a low command pulse frequency.
 - When you want to set the travel distance for machinery per pulse to 0.01 mm, for example.

■ Parameters Requiring Settings

Parameter No.	Parameter name	Explanation	Reference
Pn202	Electronic gear ratio G1 (denominator)	Set the pulse rate for the command pulse and Servomotor travel distance. When G1/G2 = 1, if the pulse (encoder resolution x 4) is input, the Servomotor will rotate once (i.e., the internal driver will rotate x 4). (See note 1.)	4-4-4 Parameter Details
Pn203	Electronic gear ratio G2 (numerator)		

- Note 1.** Set within the range $0.01 \leq G1/G2 \leq 100$.
- Note 2.** These parameters become effective when the power is turned ON again after having been turned OFF. (Check to see that the LED display has gone OFF.)
- Note 3.** With the default setting ($G1/G2 = 4$), the Servomotor will rotate once when the encoder resolution pulses are input.
- Note 4.** One position deviation (deviation counter) display and positioning completed range pulse make one input pulse. (This is called a command unit.)

■ Operation

- **Servomotor with 2,048 (Pulses/Rotation) Encoder**
- When set to $G1/G2 = 8192/1000$, the operation is the same as for a 1,000-pulses/rotation Servomotor.

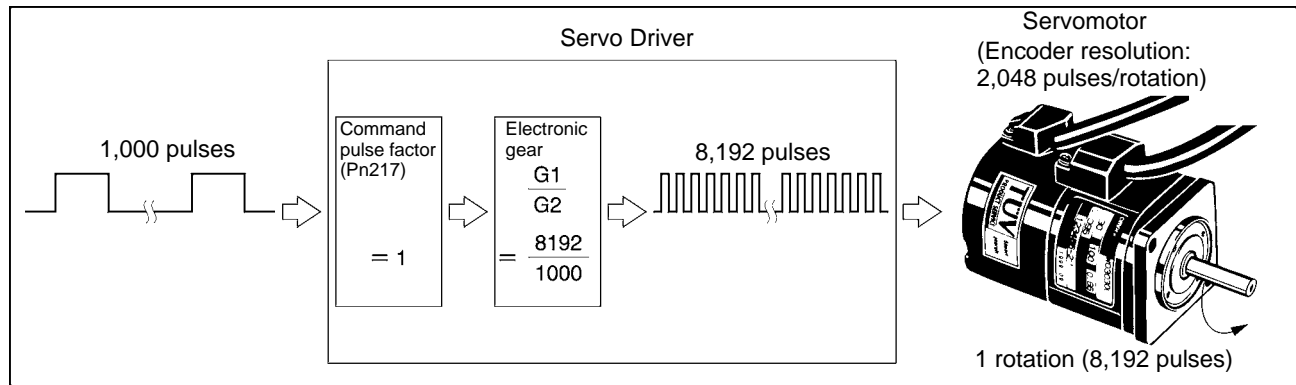

- Note 1.** If the PSEL (command pulse factor switching) input is ON when Pn218.0 (command pulse factor switching selection) is set to 1, the result from multiplying the set value in Pn217 (command pulse factor) is multiplied again by the electronic gear ratio.
- Note 2.** Command pulse factor switching is a new function supported by Servo Drivers with software version "r.0037."

4-5-13 Position Command Filter Function (Position)

■ Functions

- Perform soft start processing for the command pulses using the selected filter to gently accelerate and decelerate.

- Select the filter characteristics using Pn207.0 (position command filter selection).
- When Pn204 (position command filter time constant 1) is selected, acceleration and deceleration are performed using the primary filter (exponentiation function).
- When Pn208 (position command filter time constant 2) is selected, acceleration and deceleration are linear.
- This function is effective in the following cases:
 - There is no acceleration/deceleration function in the command pulse (controller).
 - The command pulse frequency changes rapidly, causing the machinery to vibrate during acceleration and deceleration.
 - The electronic gear setting is high ($G1/G2 = \geq 10$).

■ Parameters Requiring Settings

Parameter No.	Parameter name	Explanation	Reference
Pn207.0	Select position control filter	Select either primary filter (setting: 0), or linear acceleration and deceleration (setting: 1).	4-4-4 Parameter Details
Pn204	Position control filter time constant 1 (primary filter)	Enabled when Pn207.0 = 0. Be sure to set the primary filter time constant (setting range = 0 to 6400 (x 0.01 ms)).	
Pn208	Position control filter time constant 2 (linear acceleration and deceleration)	Enabled when Pn207.0 = 1. Be sure to set the acceleration and deceleration times (setting range = 0 to 6400 (x 0.01 ms)).	

Note If not using the position command filter function, set each content to 0 (i.e., the default setting).

■ Operation

- The characteristics for each filter are shown below.
- Servomotor acceleration and deceleration are delayed further than the characteristics shown below due to position loop gain delay.

Acceleration: $2/Kp$ (s); Deceleration: $3/Kp$ (s); Kp: Position loop gain (Pn102)

● Primary filter

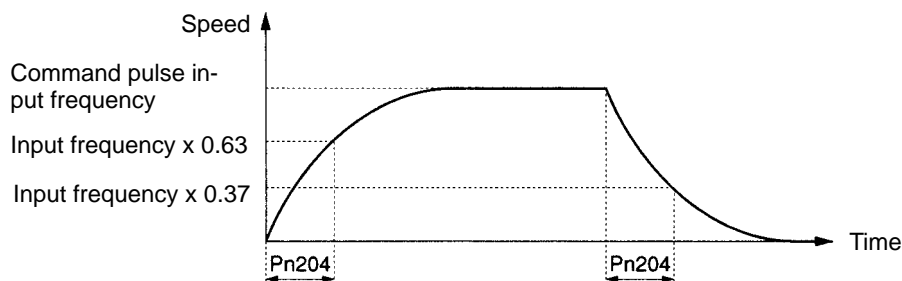

• Linear acceleration and deceleration

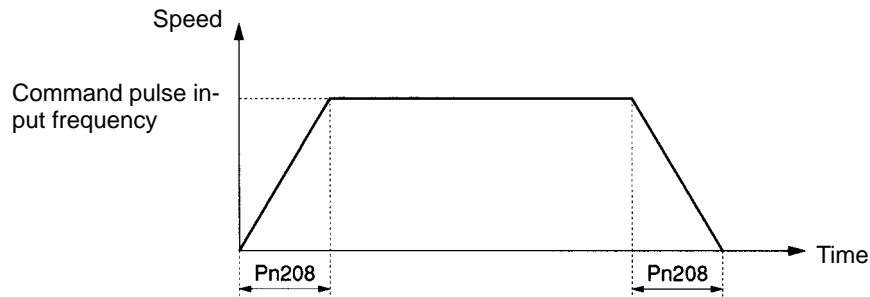

4-5-14 Position Lock Function (Speed, Internally-set Speed Control)

■ Functions

- If controlling the position without adding a position control loop, the position may slip due to temperature drift from the A/D converter, etc. In this case, this function stops the position loop by using an external signal to switch from Speed Control Mode to Position Control Mode.
- If position lock command (PLOCK: CN1-41) is input, when the number of Servomotor rotations is equal to or less than the rotation speed set in Pn501 (position lock rotation speed), the Unit switches from Speed Control Mode to Position Control Mode, and the Servomotor becomes position locked (Pin No. is allocated in the default settings).
- When the internal speed control value is equal to or greater than Pn501 (position lock rotation speed), the Servomotor will rotate.
- Loop gain during position lock is set using Pn102 (position loop gain).

■ Parameters Requiring Settings

Parameter No.	Parameter name	Explanation	Reference
Pn50d.0	Input signal selection 4 PLOCK signal selection	PLOCK must be allocated. (See note 1.)	4-4-3 Important Parameters
Pn501	Position lock rotation speed	Set the position lock rotation speed. Setting range: 0 to 10,000 (r/min).	4-4-4 Parameter Details
Pn102	Position loop gain	Use this parameter to adjust the lock force during position lock.	

Note 1. If changing the default setting, set Pn50A.0 (input signal selection mode) to 1 (user-defined settings).

Note 2. Set Pn000.1 (control mode selection) to A (speed control with position lock function) to allocate PLOCK to pin CN1-41.

■ Operation

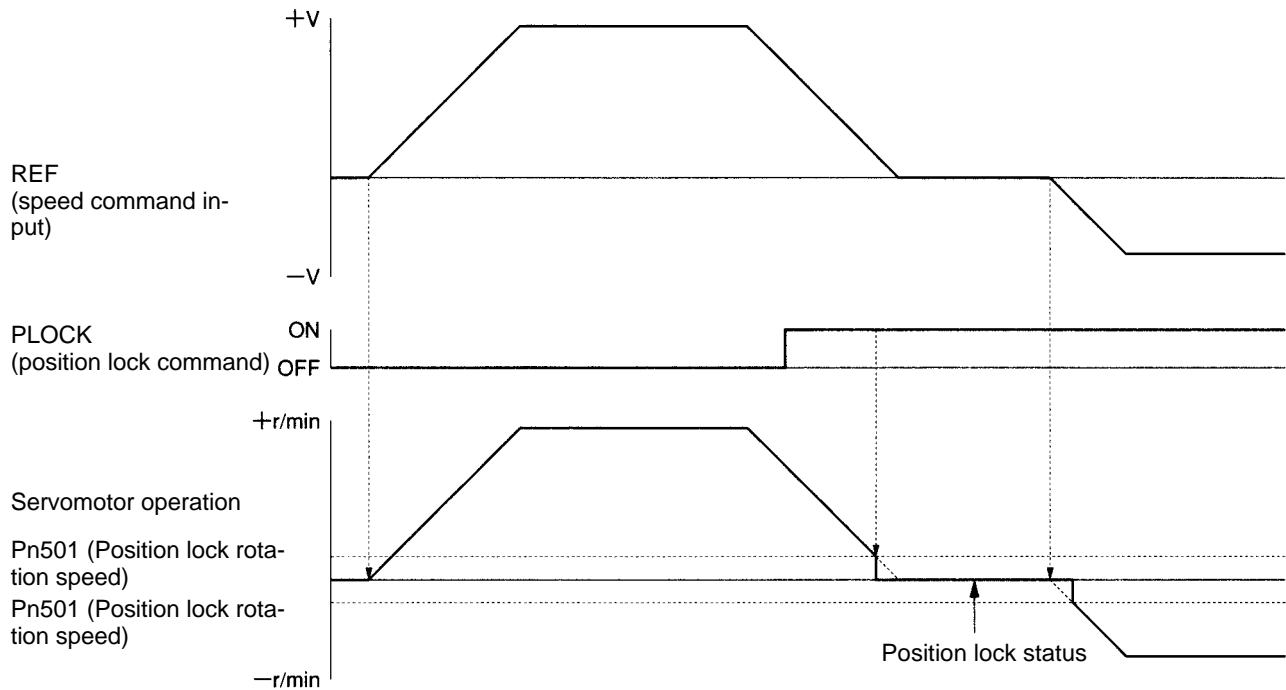

4-5-15 Speed Limit Function (Torque)

■ Functions

- This function limits Servomotor rotation speed when torque control is used.
- Set a limit so that the Servomotor rotation speed does not exceed the maximum speed of the mechanical system.
- Outside of the speed limit range, a torque in proportion to the difference from the speed limit value is generated to slow down the Servomotor rotation speed. In such cases the number of Servomotor rotations does not necessarily match the speed limit value. (The number of Servomotor rotations varies depending on the load.)
- There are two methods that can be used for limiting the speed:
 - Apply a constant fixed speed limit for torque control, by means of user parameters.
 - Limit the speed by means of analog voltage. Use REF (speed command input) as an analog speed limit input.
- When the speed limit is in operation, VLIMIT (speed control output) is output (when the signal has been allocated in Pn50F.1).
- The Servomotor rotation speed is limited by the smallest limit among the speed limits and analog speed limits set in the parameters.

● Parameters Requiring Settings

Parameter No.	Parameter name	Explanation	Reference
Pn407	Speed limit	Set the speed limit for torque control. Setting range: 0 to 10,000 (r/min).	4-4-4 Parameter Details

● **Limiting the Speed with Analog Voltage**

- When Pn002.1 (speed command input switching) is set to 1, REF (speed command input) becomes the analog speed limit input terminal, so you can limit the speed on multiple levels. The speed limit value can be calculated from the following equation:
- Absolute REF voltage (V) / Pn300 (speed command scale) x 100 x rated rotation speed (r/min.)
- Regardless of whether the voltage is positive or negative, both forward and reverse directions have the same limits (taken as absolute values).

Parameter No.	Parameter name	Explanation	Reference
Pn002.1	Function selection switch 2 Speed command input switching	Set Pn002.1 to 1 (i.e., use REF as the analog speed limit input).	4-4-4 Parameter Details
Pn300	Speed command scale	Set the REF voltage for the rated rotation speed. (See note.)	

Note The default setting is 1000 (x 0.01 V / No. or rated rotations).

4-6 Trial Operation Procedure

When you have finished installation, wiring, verifying Servomotor and Servo Driver operations (i.e., jog operation), and setting the user parameters, perform a trial operation. The main purpose of a trial operation is to confirm that the servo system is operating correctly electrically. Make sure that the host controller and all the programming devices are connected, then turn ON the power. First perform a trial operation at low speed to confirm that the system is operating correctly. Next, perform a normal run pattern to confirm that the system is operating correctly.

Note 1. If an error occurs during the trial operation, refer to *Troubleshooting* to eliminate the cause. Then check for safety and reset the alarm, and then retry the trial operation.

Note 2. If the system vibrates due to insufficient gain adjustment, making it difficult to check the operation, refer to *4-7 Making Adjustments*, and adjust the gain.

■ Preparation for Trial Operation

Turn OFF the Power

Some parameters are enabled by turning OFF the Unit, then turning it ON again. Consequently, first turn OFF the power to the control circuits and main circuits.

Mechanical System Connection

Firmly connect the Servomotor shaft and the load (i.e., the mechanical system). Tighten screws to make sure they are not loose.

Absolute Encoder Setup ABS

If using Servomotor with an absolute encoder, refer to *4-2-2 Absolute Encoder Setup and Battery Changes* for the setup procedure. After performing a jog operation, the amount of multi-turn rotation may be too large, so when connecting the absolute encoder to the mechanical system, be sure to set the rotation speed to zero.

Turning OFF the Servomotor

In order that the Servomotor can be immediately turned OFF if an abnormality occurs in the machinery, set up the system so that the power and the RUN command can be turned OFF.

■ Trial Operation

1. Turn ON the Power Supply.

- Turn ON the power supply to the control circuits and main circuits, and then turn ON the RUN command.
- Check that the Servomotor is ON.

2. Low-speed Operation

- Send a low speed command from the host controller to rotate the Servomotor. (The definition of low speed varies depending on the mechanical system, but a rough estimate is 1/10 to 1/5 normal operating speed.)
- Check the following items.
 - Is the emergency stop operating correctly?
 - Are the limit switches operating correctly?
 - Is the operating direction of the machinery correct?
 - Are the operating sequences correct?
 - Are there any abnormal sounds or vibration?
 - Is any error (or alarm) generated?

Note 1. If anything abnormal occurs, refer to *Chapter Troubleshooting* and apply the appropriate countermeasures.

Note 2. If the system vibrates due to insufficient gain adjustment, making it difficult to check the operation, refer to *4-7 Making Adjustments*, and adjust the gain.

3. Operation Under Actual Load Conditions

- Operate the Servomotor in a regular pattern and check the following items.

Is the operating speed correct? (Use the speed feedback monitor.)

Is the load torque roughly equivalent to the measured value? (Use the torque command monitor and the accumulated load monitor.)

Are the positioning points correct?

When an operation is repeated, is there any discrepancy in positioning?

Are there any abnormal sounds or vibration?

Is either the Servomotor or the Servo Driver abnormally overheating?

Is any error (or alarm) generated?

Note 1. Refer to *4-9-3 Monitor Mode* for how to display the speed feedback monitor, torque command monitor, and the cumulative load rate monitor.

Note 2. If anything abnormal occurs, refer to *Troubleshooting* and apply the appropriate countermeasures.

Note 3. If the system vibrates due to insufficient gain adjustment impeding, making it difficult to check the operation, refer to *4-7 Making Adjustments*, and adjust the gain.

4. Completing the Trial Operation

- Performing the above completes the trial operation. Next, adjust the gain to improve command efficiency. (Refer to *4-7 Making Adjustments* for details.)

4-7 Making Adjustments

The OMNUC W-series AC Servo Driver is equipped with an online auto-tuning function. Use this function to easily adjust the gain even if you are using a servo system for the first time. If you cannot use the online auto-tuning function, adjust the gain manually.

4-7-1 Online Auto-tuning

■ What Is Online Auto-tuning?

- Online auto-tuning is a control function that measures the driver's load inertia while it is operating, and attempts to maintain constantly the target speed loop gain and position loop gain.

Note You cannot use online auto-tuning in the following cases.

- When the Torque Control Mode is used for control.
- When IP control is used for a speed control loop (Pn10b.1 = 1).
- When using No. 2 gain for control (i.e., when GSEL (gain switching input) is input or automatic gain switching is used).
- When the torque feed-forward function is used (Pn002.0 = 2).
- When the speed feedback compensation function is used (Pn110.1 = 0).

■ Online Auto-tuning Related Settings

- The following tables show the user parameters and System Check Modes relating to online auto-tuning.

• User Parameters (Pn□□□)

Parameter No.	Parameter name	Explanation
Pn100	Speed loop gain	Target value for auto-tuning
Pn101	Speed loop integration time constant	Integration time constant for auto-tuning
Pn102	Position loop gain	Target value for auto-tuning
Pn103	Inertia ratio	Initial value for auto-tuning
Pn110	Online auto-tuning setting	Select auto-tuning function
Pn401	Torque command filter time constant	Filter time constant for auto-tuning

• System Check Mode (Fn□□□)

Function code	Function name	Explanation
Fn001	Rigidity setting for online auto-tuning	Select 10 stages from a combination of Pn100, Pn101, Pn102, and Pn401. (See note.)
Fn007	Storing of online auto-tuning results	The inertia ratio calculated using online auto-tuning is written to Pn103 (inertia ratio).

Note The selected value is written to the user parameters.

■ Online Auto-tuning Procedure

- Use the following procedure when using the online auto-tuning function.

Note If the online auto-tuning is set to be always enabled, the Servomotor may become unstable due to extreme vibration when the load fluctuates. It is recommended that you perform online auto-tuning once, write the results (inertia ratio) to the user parameters, then run the operation with the online auto-tuning turned OFF.

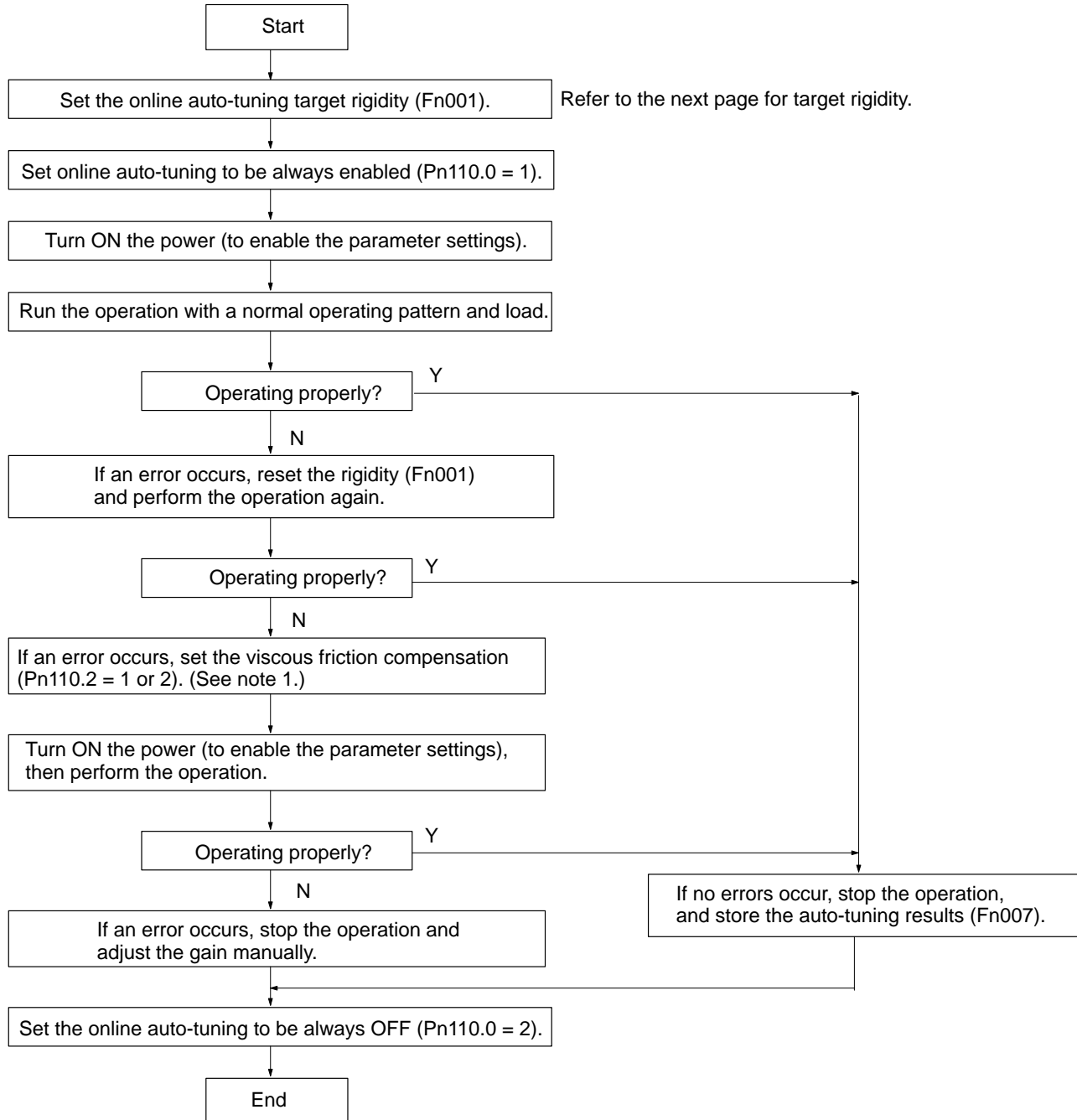

Note 1. Determine the suitable parameter setting using the torque commands within a constant velocity range (Un002).

Note 2. For System Check Mode operations, refer to 4-11-2 Online Auto-Tuning Related Functions.

■ **Selecting Mechanical Rigidity During Online Auto-tuning (Fn001)**

- Setting the rigidity during online auto-tuning sets the servo system's target speed loop gain and position loop gain.
- Select the rigidity setting (Fn001) from the following 10 levels to suit the mechanical system.

Response	Rigidity setting Fn001 (d.00□□)	Position loop gain (S ⁻¹) Pn102	Speed loop gain (Hz) Pn100	Speed loop integration time constant (x 0.01 ms) Pn101	Torque command filter time constant (x 0.01 ms) Pn401	Representative applications (mechanical system)
Low	01	15	15	6000	250	Articulated robots, harmonic drives, chain drives, belt drives, rack and pinion drives, etc.
	02	20	20	4500	200	
	03	30	30	3000	130	
Medium	04	40	40	2000	100	XY tables, Cartesian-coordinate robots, general-purpose machinery, etc.
High	05	60	60	1500	70	Ball screws (direct coupling), feeders, etc.
	06	85	85	1000	50	
	07	120	120	800	30	
	08	160	160	600	20	
	09	200	200	500	15	
	10	250	250	400	10	

Note 1. The servo-system loop gain will rise in response to a higher rigidity setting, shortening positioning time. If the setting is too large, however, the machinery may vibrate, so make the setting small.

Note 2. When setting the rigidity, the user parameters in the above table will change automatically.

Note 3. If you enable auto-tuning without setting the rigidity, the user parameter settings (Pn102, Pn100, Pn101, and Pn401) will be used as the tuning target values.

■ Online Auto-tuning Related User Parameters

Parameter No.	Parameter name	Explanation				Default setting	Unit	Setting range	Restart power ?
		Digit No.	Name	Setting	Explanation				
Pn100	Speed loop gain	Adjusts speed loop responsiveness.				80	Hz	1 to 2000	No
Pn101	Speed loop integration time constant	Speed loop integration time constant				2000	x 0.01 ms	15 to 51200	No
Pn102	Position loop gain	Adjusts position loop responsiveness.				40	1/s	1 to 2000	No
Pn103	Inertia ratio	Sets the ratio using the mechanical system inertia to Servomotor rotor inertia ratio.				300	%	0 to 10000	No
Pn110	Online auto-tuning setting	0	Online auto-tuning selection	0	Turns ON the power supply, then performs auto-tuning on the RUN startup only.	0012	---	---	Yes
				1	Auto-tuning always ON.				
				2	Auto-tuning OFF.				
		1	Speed feedback compensation function selection	0	ON				
				1	OFF				
		2	Viscous friction compensation function selection	0	Friction compensation: OFF				
				1	Friction compensation: Rated torque ratio (small)				
				2	Friction compensation: Rated torque ratio (large)				
		3	Not used.	0	Do not change the setting.				
		Pn401	Torque command filter time constant	Sets the filter time constant for the internal torque command.					

Note Refer to 4-4-4 Parameter Details for details of each parameter.

4-7-2 Manual Tuning

■ Rigidity Settings During Online Auto-tuning (Fn001)

- If you set the rigidity during online auto-tuning, the gains corresponding to machine rigidity are set automatically. Even if you adjust the gain as an initial setting using manual tuning, you can perform tuning comparatively quickly, so we recommend setting the rigidity (Fn001) first.
- Select the rigidity setting to suit the mechanical system from the following 10 levels.

Note Refer to 4-11-2 Online Auto-tuning Related Functions for System Check Mode operations.

Response	Rigidity setting Fn001 (d.00□□)	Position loop gain (S ⁻¹) Pn102	Speed loop gain (Hz) Pn100	Speed loop integration time constant (x 0.01 ms) Pn101	Torque command filter time constant (x 0.01 ms) Pn401	Representative applications (mechanical system)
Low	01	15	15	6000	250	Articulated robots, harmonic drives, chain drives, belt drives, rack and pinion drives, etc.
	02	20	20	4500	200	
	03	30	30	3000	130	
Medium	04	40	40	2000	100	XY tables, Cartesian-coordinate robots, general-purpose machinery, etc.
High	05	60	60	1500	70	Ball screws (direct coupling), feeders, etc.
	06	85	85	1000	50	
	07	120	120	800	30	
	08	160	160	600	20	
	09	200	200	500	15	
	10	250	250	400	10	

Note 1. The servo-system loop gain will rise in response to a higher rigidity setting, shortening positioning time. If the setting is too large, however, the machinery may vibrate, so make the setting small.

Note 2. When the rigidity is set, the user parameters in the above table will change automatically.

Manual Tuning-related User Parameters

Parameter No.	Parameter name	Explanation	Default setting	Unit	Setting range	Restart power?
Pn100	Speed loop gain	Adjusts speed loop responsiveness.	80	Hz	1 to 2000	No
Pn101	Speed loop integration time constant	Speed loop integration time constant	2000	x 0.01 ms	15 to 51200	No
Pn102	Position loop gain	Adjusts position loop responsiveness.	40	1/s	1 to 2000	No
Pn103	Inertia ratio	Sets the ratio using the mechanical system inertia to Servomotor rotor inertia ratio.	300	%	0 to 1000	No
Pn401	Torque command filter time constant	Sets the filter time constant for the internal torque command.	40	x 0.01 ms	0 to 65535	No

Note Refer to 4-4-4 *Parameter Details* for details of each parameter.

■ Manual Tuning Procedure (During Position Control)

- Use the following procedure to perform operation with position control (pulse train input).

Note Turn OFF online auto-tuning (Pn110.0 = 2).

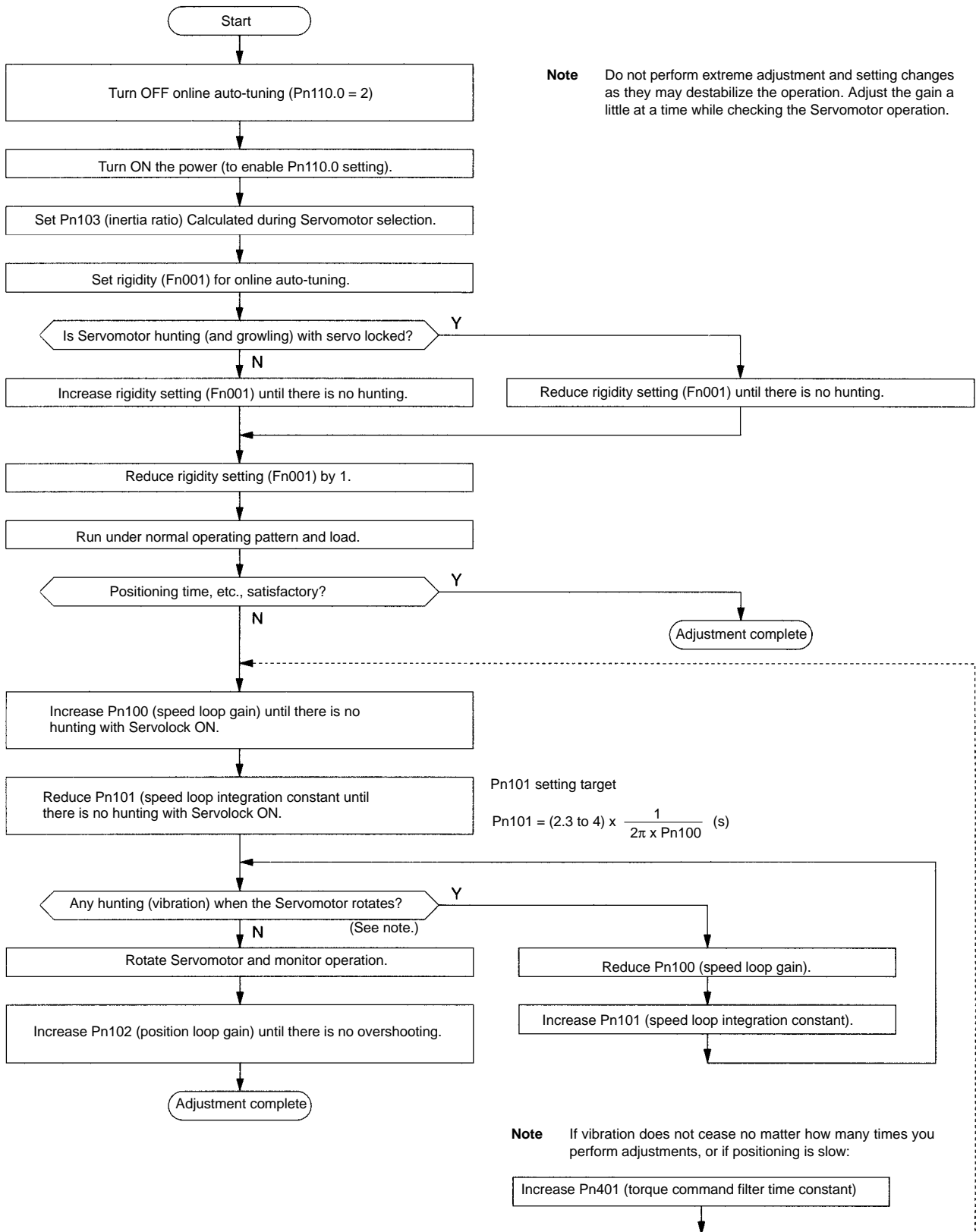

■ Manual Tuning Procedure (During Speed Control)

- Use the following procedure to perform operation with speed control (speed command voltage input).

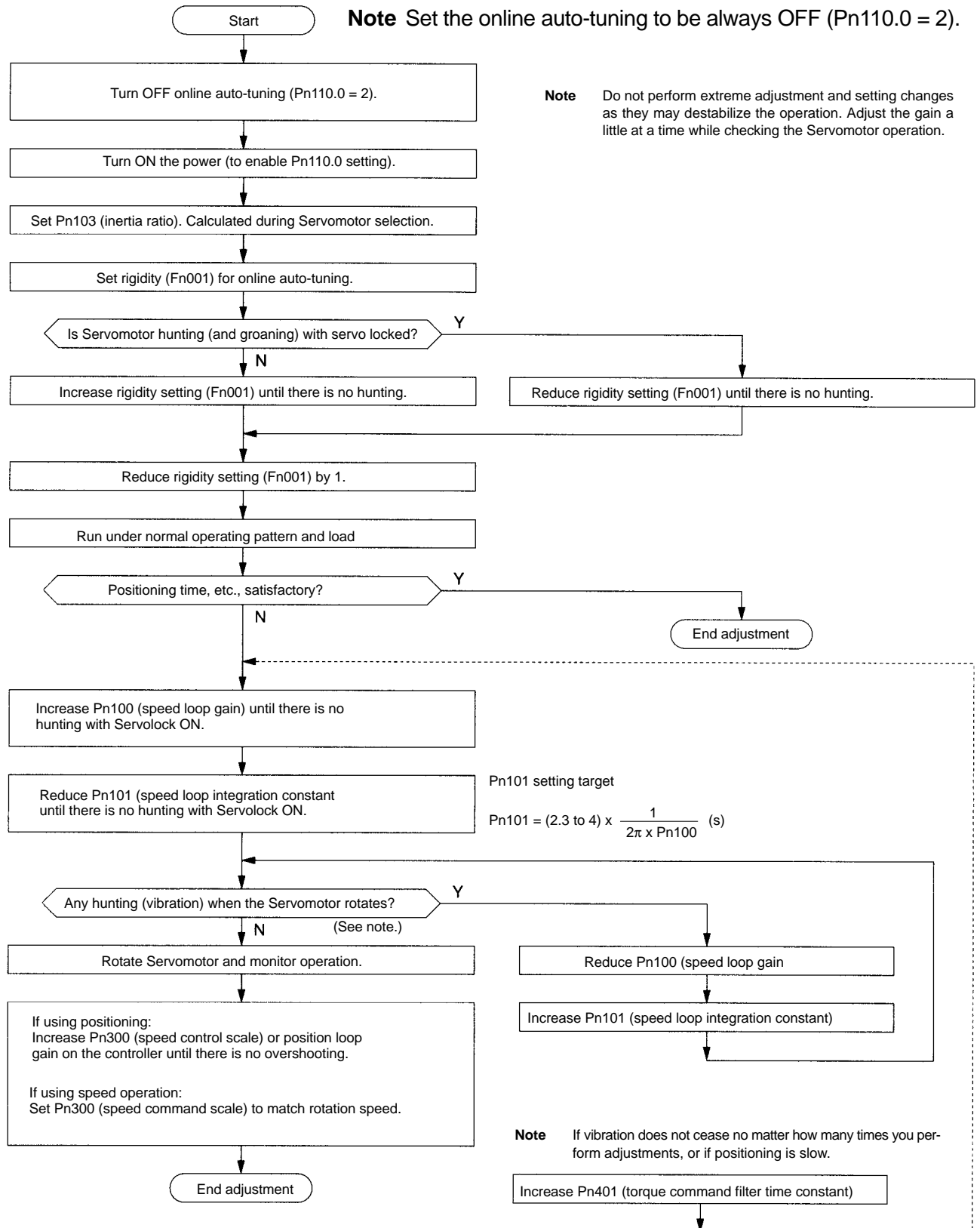

■ Position Loop Block Diagram (Reference)

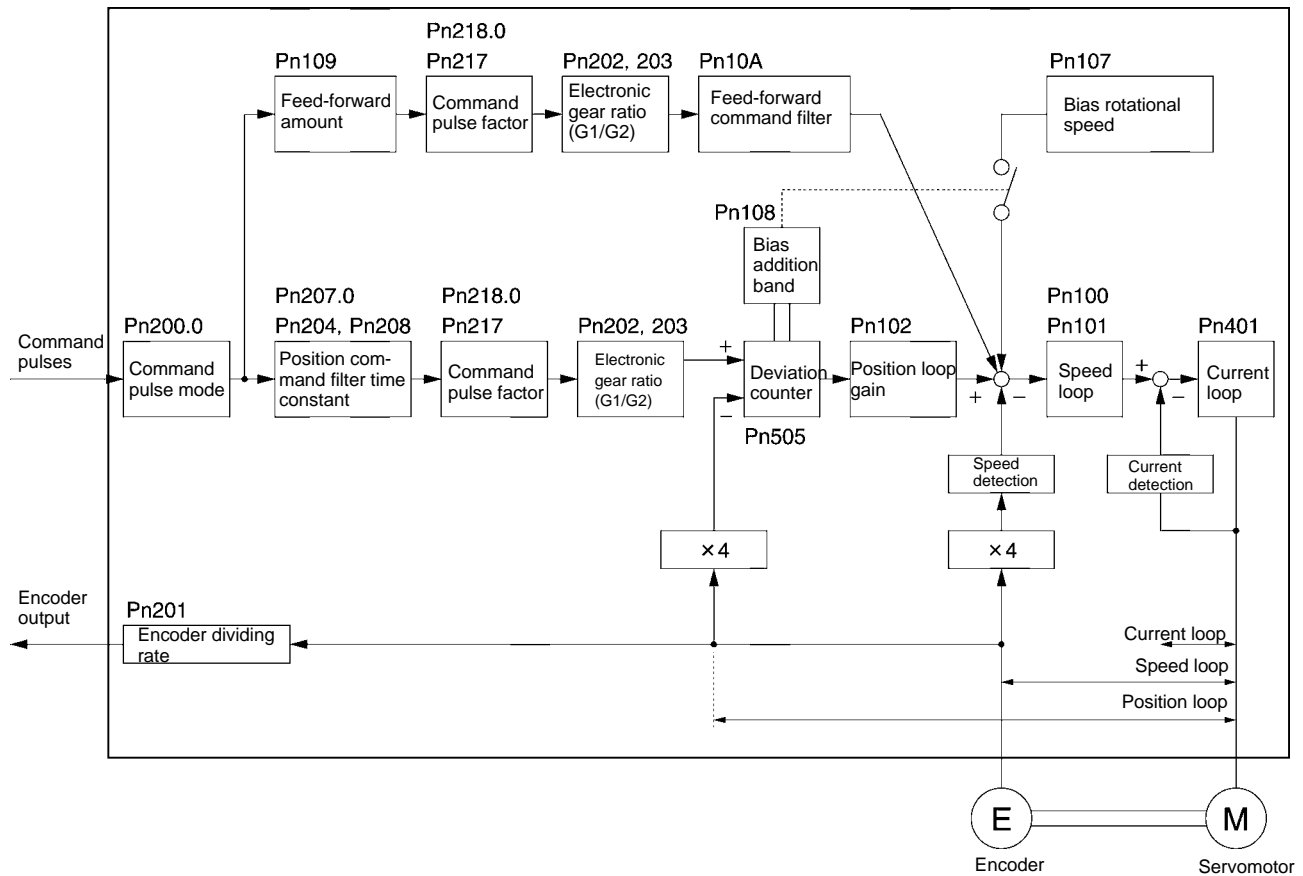

■ Gain Adjustment Procedure

- The servo system control block is configured from the following three loops: Position loop, speed loop, and current loop.
- The current loop is the innermost loop, followed by the speed loop, then the position loop.
- Outputs from outer loops become inputs to inner loops, and for outer loops to perform suitable control operations, it is necessary that inner loops respond sufficiently to their inputs, i.e., inner loop responsiveness must be high. Also, be sure to adjust the gain starting from the innermost loop.
- The current loop is adjusted at the factory for sufficient response, so adjust the speed loop first, then adjust the position loop.
- Adjust the speed loop to increase compliance with the speed command. Perform the adjustment while checking the servo rigidity (force needed to maintain position against external force) with the Servo-lock ON.
- Adjust the position loop to increase compliance with the position command. Input position commands using an actual operating pattern, and perform the adjustment while checking the position-fixing time.

4-8 Advanced Adjustment Functions

4-8-1 Bias Function (Position)

■ Functions

- The bias function shortens positioning time by adding bias revolutions to speed commands (i.e., commands to the speed control loop).
- If the residual pulses in the deviation counter exceed the setting in Pn108 (bias addition band), the speed set in Pn107 (bias rotational speed) is added to the speed command, and when the residual pulses in the deviation counter are within the setting in Pn108, adding to the number of bias rotations stops.

■ Parameters Requiring Settings

Parameter No.	Parameter name	Explanation	Reference
Pn107	Bias rotational speed	Set the rotation speed to be added to the bias (setting range: 0 to 450 (r/min.)).	4-4-4 Parameter Details
Pn108	Bias addition band	Set the residual pulses to be added to the number of bias rotations using command units (setting range: 0 to 250 (command units)).	

Note 1. When not using the bias function, set Pn107 to 0.

Note 2. If the bias rotational speed is set too high, it will cause Servomotor operation to be unstable. The optimum setting depends on the load, the gain, and the bias addition band, so adjust the setting while observing the Servomotor response. (Begin with a bias setting of Pn107 = 0, and gradually increase it.)

■ Setting Procedure

- Complete the gain adjustment before adjusting the bias.
- Increase the Pn107 (bias rotational speed) setting until positioning time is minimal. At this point, if there are no problems with using overshoot, adjustments are complete.
- If the overshoot is too large, increase Pn108 (bias addition band) to reduce it.

■ Operation

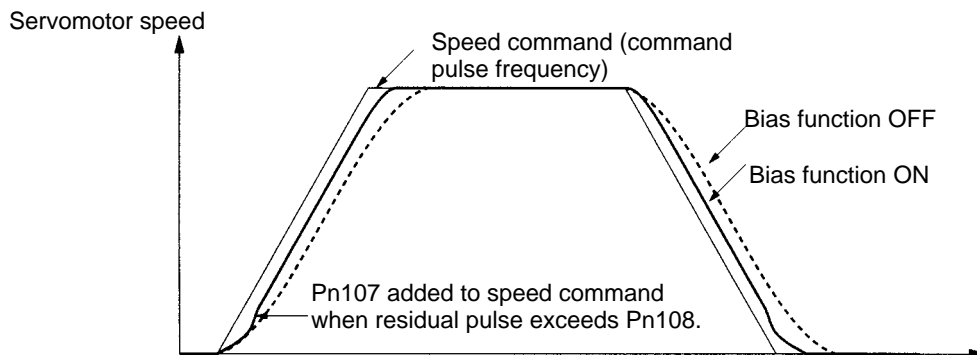

Note Refer to *Position Loop Block Diagram* in 4-7-2 *Manual Tuning* for the internal processing block configuration.

4-8-2 Feed-forward Function (Position)

■ Functions

- This function shortens the positioning time by automatically adding the command pulse input (CW/CCW) differential value to the speed loop in the Servo Driver.
- Perform feed-forward compensation to increase servo gain efficiency, thus improving responsiveness. There is very little effect, however, on systems with sufficiently high position loop gain.

Note Refer to *Position Loop Block Diagram* in *4-7-2 Manual Tuning* for the internal processing block configuration.

■ Parameters Requiring Settings

Parameter No.	Parameter name	Explanation	Reference
Pn109	Feed-forward amount	Set the feed-forward gain (setting range: 0 to 100 (%)).	4-4-4 Parameter Details
Pn10A	Feed-forward command filter	Set the feed-forward command filter (primary lag). (Setting range: 0 to 6400 (x 0.01 ms).)	

Note When not using the feed-forward function, set Pn10A to 0.

■ Setting Procedure

- Finish adjusting the gain before adjusting the feed-forward.
- Increase the Pn109 (feed-forward amount) setting until positioning time is minimal. At this point, if there are no problems with using overshoot, adjustments are complete. A high setting may cause the machinery to vibrate. With ordinary machinery, set the gain to 80% maximum. (Adjust the gain while checking the machine response.)
- If the overshoot is too large, increase Pn10A (feed-forward command filter) to reduce the it.

4-8-3 Torque Feed-forward Function (Speed)

■ Functions

- The torque feed-forward function reduces the acceleration time by adding the value of TREF (torque command input) to the current loop; it can be used with speed control.
- Normally a differential value is generated in the controller and this value is input to TREF.
- Overshooting will occur if the feed-forward amount (the voltage input to TREF) is too high, so adjust Pn400 (torque command scale) as required.

Torque Feed-forward Function Block Diagram

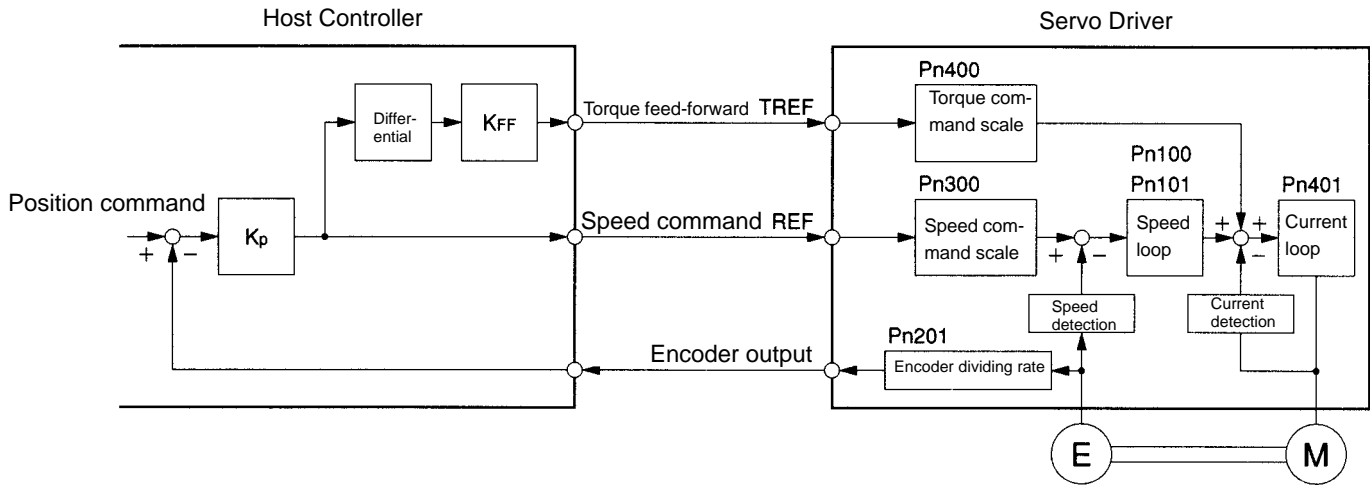

Parameters Requiring Settings

Parameter No.	Parameter name	Explanation	Reference
Pn002.0	Torque command input switching	Set Pn002.0 to 2 (use TREF as torque feed-forward input)	4-4-4 Parameter Details
Pn400	Torque command scale	Adjust the torque feed-forward amount. (See note.)	

Note The default setting is 30 (x 0.1 V / rated torque).

Operation

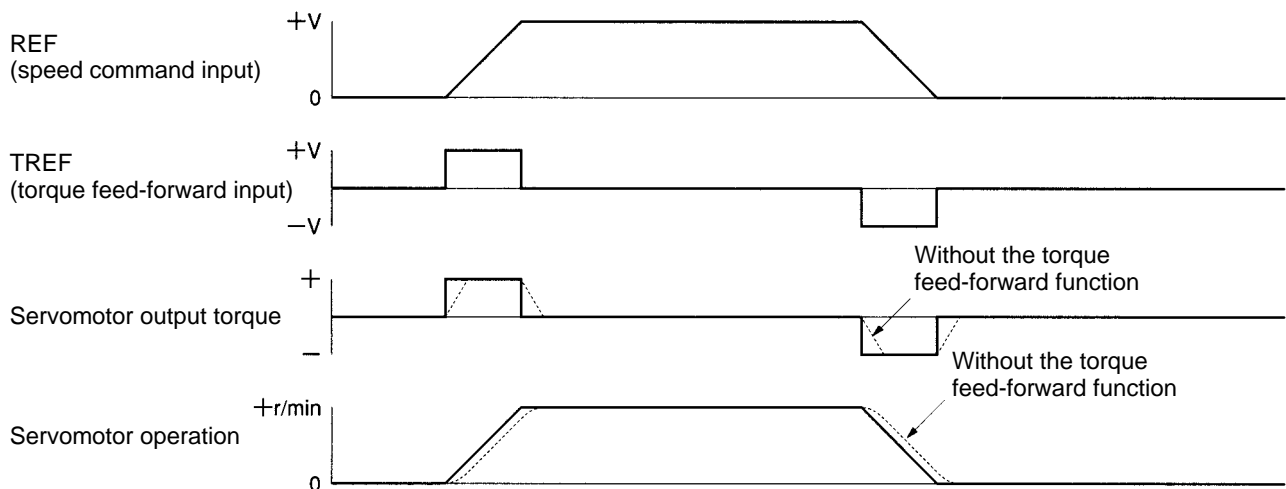

Note 1. If torque feed-forward is input when the Servomotor's rotation speed is fixed, the rotation speed won't match the speed command. Design the Controller's circuit so that torque feed-forward is applied only when the Servomotor is accelerating or decelerating.

Note 2. A torque will be generated that accelerates the Servomotor in the forward direction if torque feed-forward is applied with a positive (+) voltage. Be sure that the polarity is correct because errors such as reverse Servomotor rotation or oscillation will occur if the feed-forward is applied with a polarity opposing the acceleration direction.

4-8-4 Speed Feed-forward Function (Position)

■ Functions

- This function shortens positioning time by adding the REF (speed command input) value to the speed loop.
- Normally, the differential value for the position command (pulse train command) is generated in the controller, and input to REF.
- If the feed-forward amount (REF voltage) is too large, an overshoot may occur, so adjust Pn300 (speed command scale) as required.

Speed Feed-forward Function Block Diagram

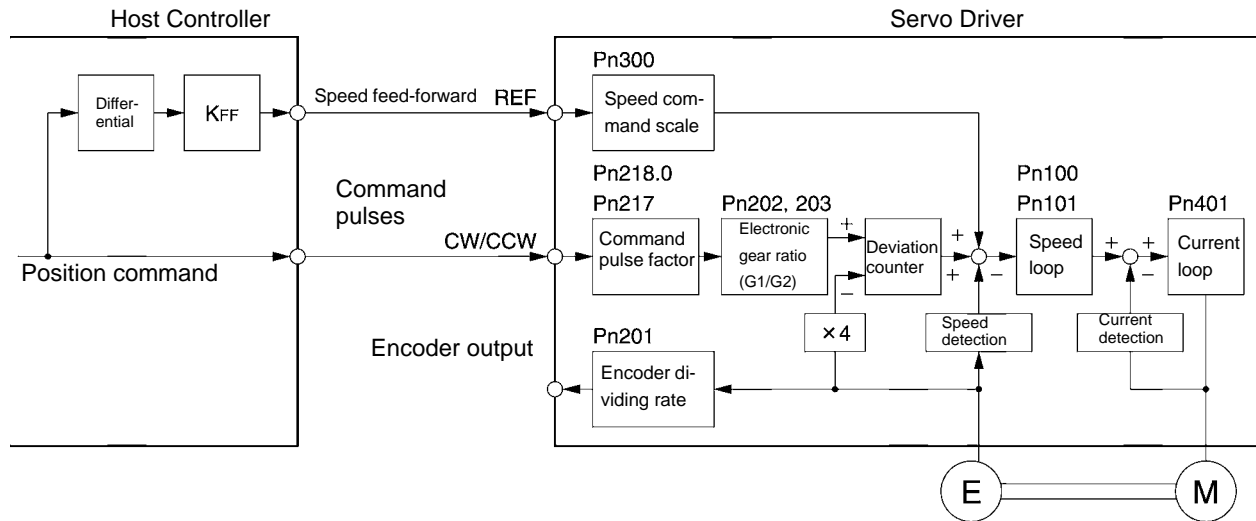

■ Parameters Requiring Settings

Parameter No.	Parameter name	Explanation	Example
Pn207.1	Speed command input switching	Set Pn207.1 to 1 (use REF as speed torque feed-forward input).	4-4-4 Parameter Details
Pn300	Speed command scale	Adjust the speed feed-forward amount. (See note.)	

Note The default setting is 1000 (x 0.01 V / rated number of revolutions).

■ Operation

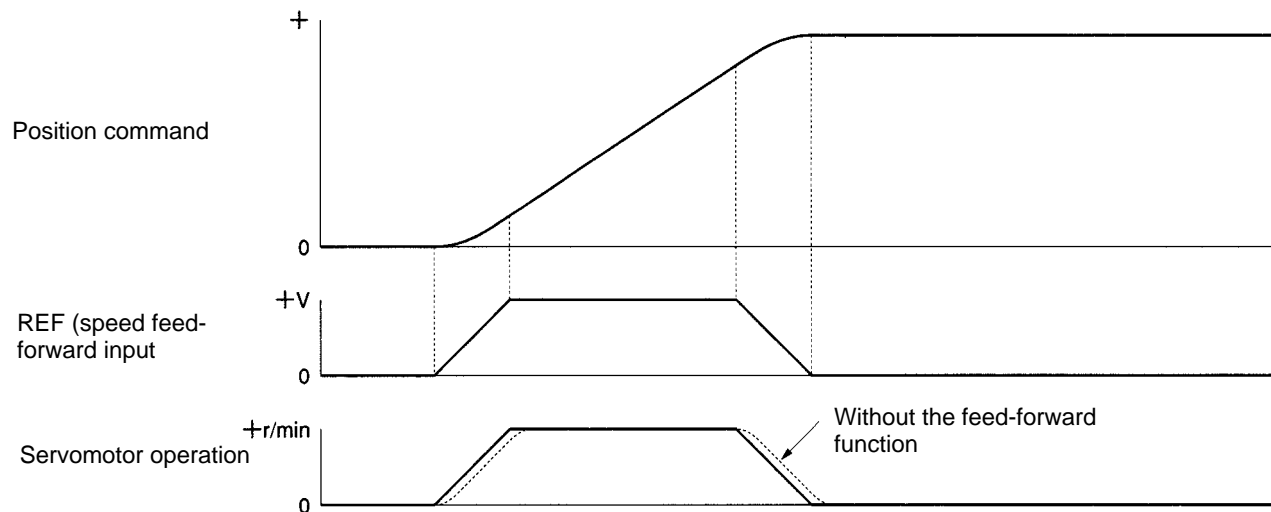

Note When a positive voltage speed feed-forward is added, a command to rotate the Servomotor forwards is added. If a reverse feed-forward command is added to the pulse train, positioning time will be lengthened, so check the polarity carefully.

4-8-5 Gain Switching (Position, Speed, Internally-set Speed Control)

■ Functions

- This function switches the speed loop and position loop gain.
- If GSEL (gain switching) signal is not being input, perform control using Pn100 (speed loop gain), Pn101 (speed loop integration constant), and Pn102 (position loop gain). If GSEL is being input, perform control using Pn104 (speed loop gain 2), Pn105 (speed loop integration constant 2), and Pn106 (position loop gain 2).
- If the mechanical system inertia fluctuates too much, or if there is no difference between operation and standby responses, you can perform applicable control using gain switching.
- If online auto-tuning is not enabled (under the conditions shown below), the gain switching function will be enabled.
 - When using the torque feed-forward function.
 - When the load inertia fluctuates by 200 ms max.
 - When rotation speed does not exceed 500 r/min., or output torque does not exceed 50% of rated torque.
 - External force is constantly applied, as with a vertical axis.

Note When No. 2 gain has been selected (i.e., GSEL ON), online auto-tuning will not operate normally. If using the gain switching function, turn OFF online auto-tuning (Pn110.0 = 2).

■ Parameters Requiring Settings

Parameter No.	Parameter name	Explanation	Reference
Pn50A.0	Input signal selection 1 Input signal selection mode	GSEL signal is not allocated in the default settings. Set Pn50A.0 to 1 (user-defined settings).	4-4-3 Important Parameters
Pn50d.2	Input signal selection 4 GSEL signal selection	Allocate GSEL signal.	
Pn104	No. 2 speed loop gain	Set the speed loop gain for when GSEL is ON.	4-4-4 Parameter Details
Pn105	No. 2 speed loop Differential time constant	Set the speed loop differential time constant for when GSEL is ON.	
Pn106	No. 2 position loop gain	Set the position loop gain for when GSEL is ON.	

- Adjust Pn104, Pn 105, and Pn 106 when GSEL is ON according to 4-7-2 Manual Tuning. Fn001 (rigidity setting for online auto-tuning) is not performed on No. 2 gain, however, so set the initial values for adjustment referring to the above table.

4-8-6 Automatic Gain Switching (Position Control)

■ Functions

- This function switches the speed loop and position loop gain.
- Depending on whether position commands are used, and the amount of position deviation, the No. 1 gain (Pn100, Pn101, Pn102) and No. 2 gain (Pn104, Pn105, Pn106) can be automatically switched.

Note 1. Automatic gain switching is enabled for position control only. When position control is not used, the Servomotor operates using the No. 1 gain (Pn100, Pn101, Pn102).

Note 2. When automatic gain switching is used, set the No. 1 gain for gain during operating, and set the No. 2 gain for gain while stopped.

Note 3. Automatic gain switching and gain switching using GSEL (gain switching input) cannot be used together. When Pn10b.2 (automatic gain switching selection) is set between 1 and 3, GSEL switching is disabled.

Note 4. Automatic gain switching is a new function supported by Servo Drivers with software version "r.0037."

■ Parameters Requiring Settings

Parameter No.	Parameter name	Explanation	Reference
Pn10b.2	Speed control setting — Automatic gain switching selection	Set the conditions for gain switching in Pn10b.2 1: Switches using position commands 2: Switches using position deviation 3: Switches using position commands and position deviation	4-4-4 Parameter Details
Pn124	Automatic gain switching timer	Set the switching delay time after gain switching conditions are met.	
Pn125	Automatic gain switching width	Set the amount of position deviation used as the switching condition when automatic gain switching by position deviation is used (Pn10b.2 = 2, 3).	
Pn104	No. 2 speed loop gain	Set the speed loop gain for when the Servomotor is stopped.	
Pn105	No. 2 speed loop differential time constant	Set the speed loop derivative time constant for when the Servomotor is stopped.	
Pn106	No. 2 position loop gain	Set the position loop gain for when the Servomotor is stopped.	

■ Operation

● Pn10b.2 = 1: Timing when Switching Using Position Commands

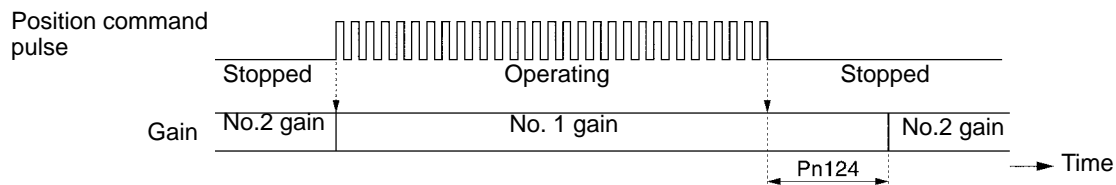

● Pn10b.2=2: Timing when Switching Using Position Deviation

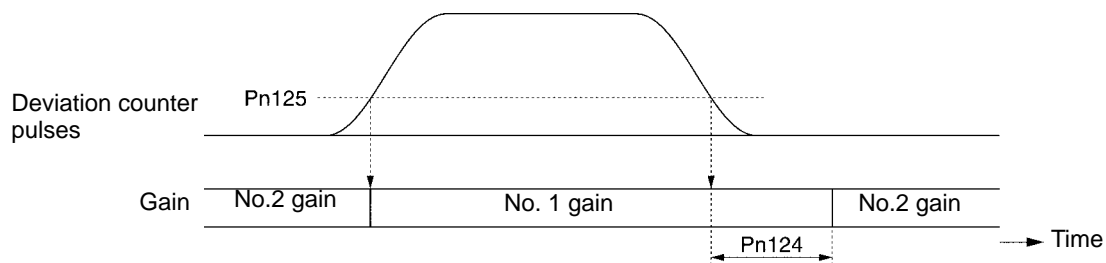

Note Pn10b.2=3: When switching is performed using position commands and position deviation, when either of the above conditions is met, the gain switches to the No.1 gain.

4-8-7 Notch Filter (Position, Speed, Internally-set Speed Control)

■ Functions

- Set whether or not to use the notch filter for internal torque commands (current loop commands). The notch filter is used to lower the responsiveness of the set frequency.

- Use the notch filter to prevent mechanical resonance. This function can be used to raise the speed loop gain and to shorten positioning time.
- With W-series AC Servo Drivers, two notch filters can be set: notch filter 1 and notch filter 2.

Note 1. The filter setting is used to prevent mechanical resonance that cannot be eliminated using gain adjustment. If the notch filter is not set carefully, the mechanical operation may become unstable. Therefore, adjust while observing the mechanical operation using a torque command monitor or other method. Make sure that an emergency stop switch is provided so that the machine can be stopped immediately.

Note 2. The Q value setting and notch filter 2 are new functions supported by Servo Drivers with software version “r.0037.”

■ Parameters Requiring Settings

Parameter No.	Parameter name	Explanation	Reference
Pn408.0	Torque command setting Notch filter 1 function selection	To use the notch filter 1 function, set Pn408.0 to 1 (notch filter 1 ON).	4-4-4 Parameter Details
Pn409	Notch filter 1 frequency	Set the machine resonance frequency.	
Pn40A	Notch filter 1 Q value	Set the Q value for notch filter 1.	
Pn408.2	Torque command setting Notch filter 2 function selection	To use the notch filter 2 function, set Pn408.2 to 1 (notch filter 2 ON).	
Pn40b	Notch filter 2 frequency	Set the machine resonance frequency.	
Pn40C	Notch filter 2 Q value	Set the Q value for notch filter 2.	

Note The Q value is a parameter that determines the characteristics of the notch filter. The smaller the Q value, the broader the frequency range that lowers the responsiveness. Therefore, the responsiveness of the current loop other than the resonance frequency is lowered. When the Q value is high, the frequency that lowers the responsiveness can be concentrated around the resonance frequency. When the impact from the load and temperature cause the resonance frequency to fluctuate, however, the notch filter effectiveness drops, so determine the optimum set value while performing adjustment.

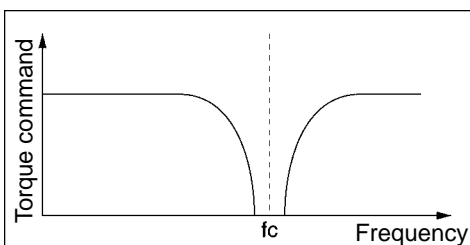

Frequency characteristics when Q = 0.7 (set value = 70)

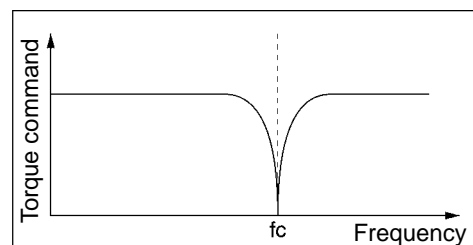

Frequency characteristics when Q = 2.0 (set value = 200)

■ Setting Procedure

- Measure the torque vibration frequency by increasing the Pn100 (speed loop gain) with the machinery vibrating slightly. Use the OMNUC W-series Servo Driver Computer Monitoring Software to measure the analog monitor (torque command monitor) output.
- Set the measured frequency using Pn409 (or Pn40b) (notch filter 1/2 frequency).
- Adjust the value of Pn409 (or Pn40b) slightly to minimize output torque vibration.
- Gradually raise the Q value (Pn40A or Pn40C) within the range in which the vibration will not increase.
- Once again, adjust Pn100 (speed loop gain), Pn101 (speed loop integration constant), Pn102 (position loop gain), and Pn401 (torque command filter time constant) according to *4-7-2 Manual Tuning*.

4-8-8 Speed Feedback Compensation (Position, Speed, Internally-set Time Control)

■ Functions

- This function shortens positioning time.
- This function works to lower the speed loop feedback gain, and raise the speed loop gain and position loop gain. Consequently, responsiveness to commands is improved, and positioning time can be shortened. Noise sensitivity is lowered, however, so positioning time cannot be shortened where there is external force applied, such as with the vertical axis.

Note If you use the speed feedback compensation function, online auto-tuning will not operate normally. To use the speed feedback compensation function, turn OFF the online auto-tuning (Pn110.0 = 2).

■ Parameters Requiring Settings

Parameter No.	Parameter name	Explanation	Reference
Pn110.1	Selects speed feedback compensation function	To use the speed feedback compensation function, set Pn110.1 to 1 (speed feedback compensation function ON).	4-4-4 <i>Parameter Details</i>
Pn111	Speed feedback compensating gain	Adjusts the speed loop feedback gain.	

- Reduce the setting value for Pn111 (speed feedback compensating gain) to increase the speed loop gain and position loop gain. If the value is too small, the response may vibrate.

■ Setting Procedure

- To perform adjustment, measure the position error and torque command. Refer to the OMNUC W-series Servo Driver personal computer monitoring software to measure the analog monitor output.
- Follow *4-7-2 Manual Tuning* to adjust Pn100 (speed loop gain), Pn101 (speed loop integration time constant), Pn102 (position loop gain), and Pn401 (torque command filter time constant) to quickly set the position error to zero without the torque command vibrating.

- After completing tuning, lower Pn111 to 10, and adjust Pn100, Pn101, Pn102, and Pn401 in the same way.

4-8-9 Speed Feedback Filter (Position, Speed, Internally-set Speed Control)

■ Functions

- This function sets the primary filter for the speed feedback gain.
- Use the filter function when you cannot raise the speed loop feedback due to mechanical system vibration, etc.

Note If you use the speed feedback compensation function, online auto-tuning will not operate normally. To use the speed feedback compensation function, turn OFF the online auto-tuning (Pn110.0 = 2).

■ Parameters Requiring Settings

Parameter No.	Parameter Name	Explanation	Reference
Pn308	Speed feedback filter time constant	Set the filter time constant for the speed feedback. (Setting range: 0 to 65535 (x 0.01 ms).)	4-4-4 Parameter Details

■ Setting Procedure

- Measure the machinery vibration cycle, and set Pn508 (speed feedback filter time constant) to that value.

4-8-10 P Control Switching (Position, Speed, Internally-set Speed Control)

■ Functions

- This function automatically switches the control method for the speed loop control from PI (proportional integration) control to P (proportional) control.
- Normally, control is sufficient using the speed loop gain and position loop gain set by auto-tuning. (So normally there is no need to change the setting.)
- Continual operation using PI control may cause switching to P control if the Servomotor speed overshoots or undershoots. (Switching to P control lowers the effective servo gain to stabilize the servo system.) You can also reduce positioning time in this way.

■ Parameters Requiring Settings

Parameter No.	Parameter name	Explanation	Reference
Pn10b.0	Speed control setting P control switching condition	Sets the condition for switching the speed loop from PI control to P control. Use Pn10C to Pn10F to make the switching level settings.	4-4-4 Parameter Details
Pn10C	P control switching (torque command)	Set when Pn10b.0 = 0 (switch using internal torque command value). Set the conditions for switching to P control using the ratio (%) of the Servomotor rated torque.	
Pn10d	P control switching (speed command)	Set when Pn10b.0 = 1 (switch using speed command value). Set the speed (r/min.) to switch to P control.	
Pn10E	P control switching (acceleration command)	Set when Pn10b.0 = 2 (switch using acceleration command value). Set the acceleration (x 10 r/min. /s) to switch to P control.	
Pn10F	P control switching (deviation pulse)	Set when Pn10b.0 = 3 (switch using deviation pulse value). Set the deviation pulse value (command unit) to switch to P control.	

- If the output torque is saturated during acceleration and deceleration, switch to P control using the internal torque command value or acceleration command value.
- If the output torque is not saturated during acceleration and deceleration, and an overshoot or undershoot occurs, switch to P control using the speed command value or deviation pulse value.

■ Operation

- Clear the speed overshoot and undershoot by switching to P control.

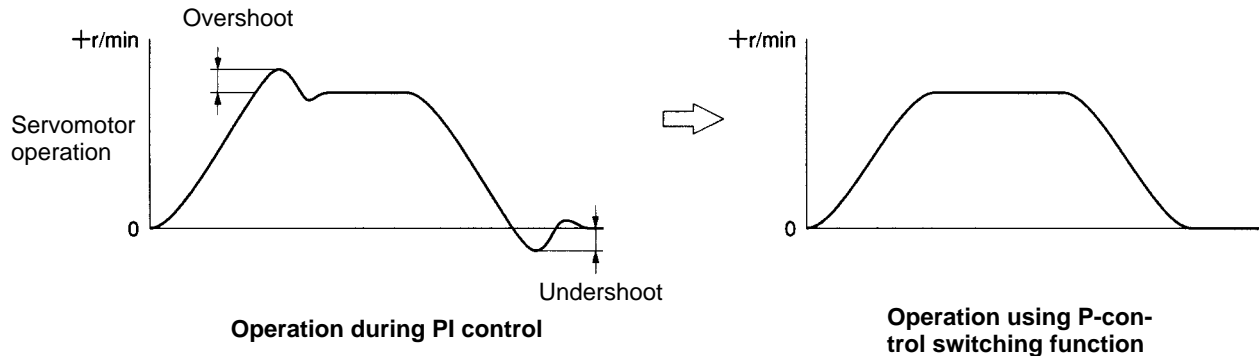

● Switching Using Torque Command

- You can switch to P control when the internal torque command value exceeds the setting in Pn10C to prevent output torque saturation and cancel speed overshoot and undershoot.

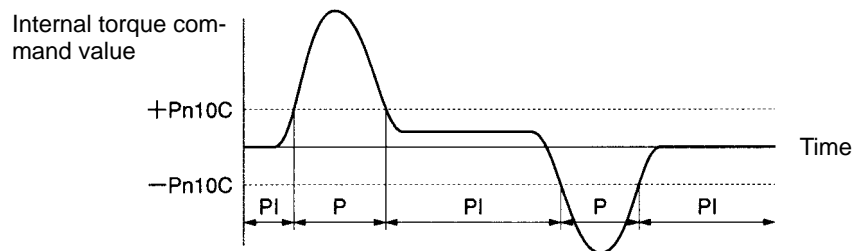

● **Switching Using Speed Command**

- You can switch to P control when the speed command value exceeds the setting in Pn10d to suppress speed overshoot and undershoot and so shorten positioning time by reducing gain in the high-speed area.

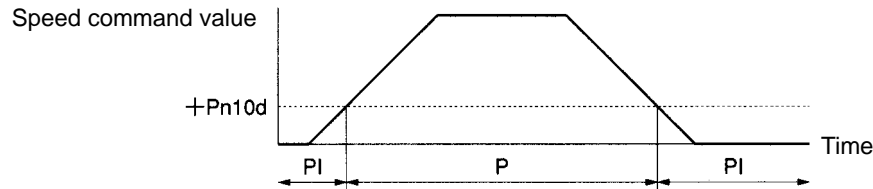

● **Switching Using Acceleration Command**

- You can switch to P control when the acceleration command value exceeds the setting in Pn10E to suppress speed overshoot and undershoot and so shorten positioning time by reducing gain in the high-speed area.

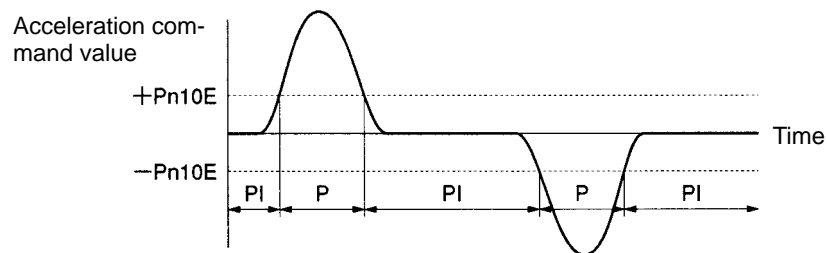

● **Switching Using Deviation Pulse**

- You can switch to P control when the deviation pulse value exceeds the setting in Pn10F to suppress speed overshoot and undershoot and so shorten positioning time by reducing gain in the high-speed area.

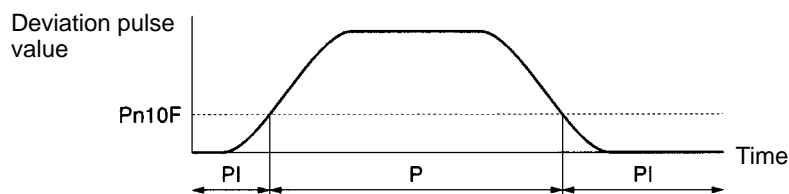

4-9 Using Displays

OMNUC C-series AC Servomotors have unique servo software that enables quantitative monitoring in real time, on digital displays, of changes in a variety of characteristics. Use these displays for checking the various characteristics during operation.

4-9-1 Power Supply Indicator and Charge Indicator

- There are two LED indicators on the Servo Driver itself. One is for the power supply, and the other is a charge indicator.

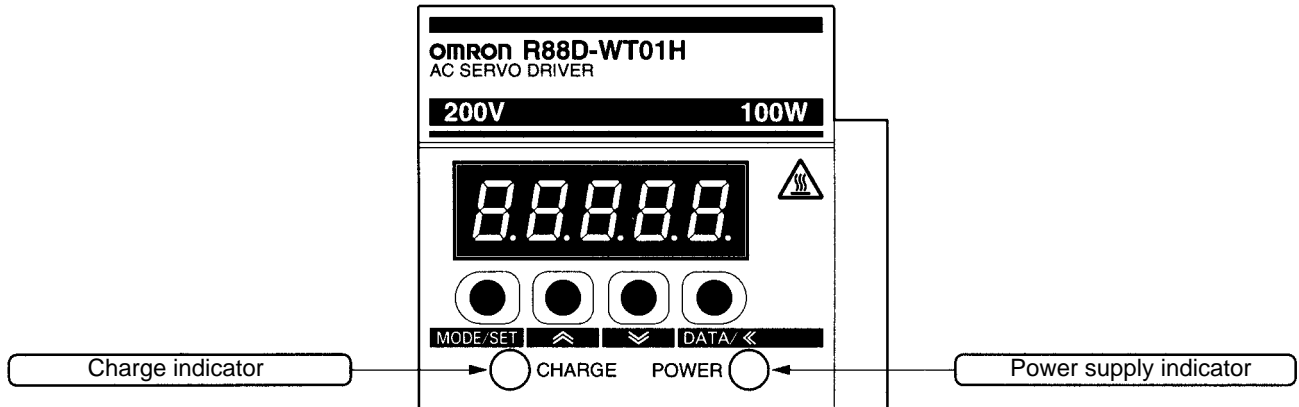

■ Indicators

Symbol	Name	Color	Function
POWER	Power supply indicator	Green	Lit when control power supply is normal.
CHARGE	Charge indicator	Red	Lit when main-circuit power supply is charging.

Note The indicator stays lit while the main circuit capacitor remains charged even after the power is turned OFF. Do not touch the Servo Driver terminal.

4-9-2 Status Display Mode

- The Status Display Mode indicates the internal status of the driver using bit display (LED ON/OFF), and symbol display (3-digit 7-segment LEDs).
- Status Display Mode is the mode in which the Servo Driver starts when the power supply is first turned ON.

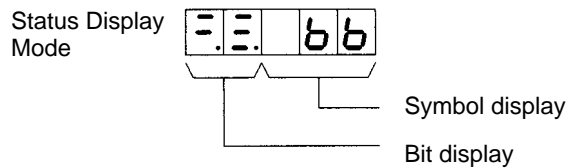

■ Bit Data Display Contents

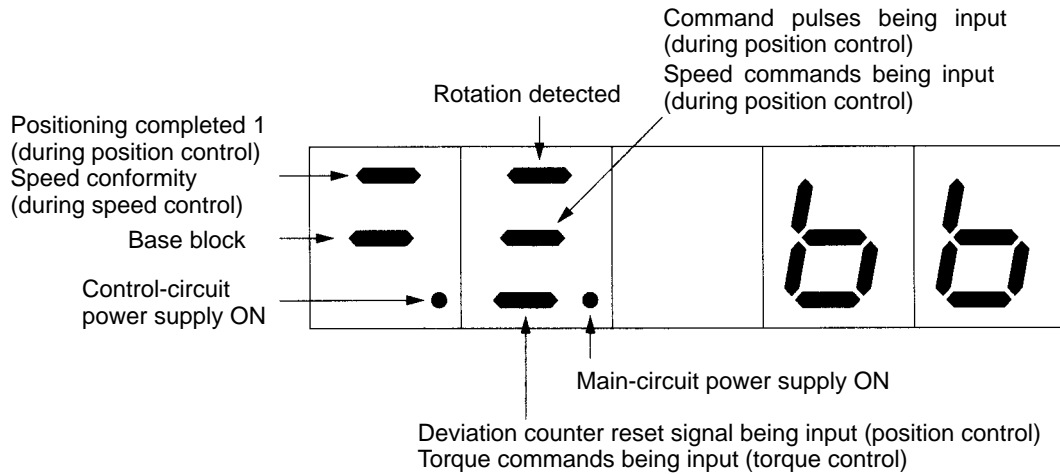

Bit data	Contents
Control-circuit power supply ON	Lit when Servo Driver control-circuit power supply is ON.
Main-circuit power supply ON	Lit when Servo Driver main-circuit power supply is ON.
Base block	Lit during base block (no power to Servomotor, servo is OFF); dimmed when servo is ON.
Positioning completed 1	Lit when the residual pulses in the deviation counter fall below the setting for Pn500 (positioning completion range 1).
Speed conformity	Lit when the Servomotor rotation speed is within the range of (speed command value \pm (Pn503 (speed conformity signal output width))).
Rotation detection	Lit when the Servomotor rotation speed is equal to or greater than Pn502 (rotation speed for motor rotation detection) setting.
Inputting command pulses	Lit when command pulses are being input.
Inputting speed command	Lit when a speed command input meets or is greater than Pn502 (rotation speed for motor rotation detection) setting.
Inputting deviation counter reset signal	Lit when the ECRST (deviation counter reset signal) is being input.
Inputting torque command	Lit when a torque command at least 10% of the rated torque is input.

■ Symbol Display Contents

Symbol display	Contents
<i>bb</i>	Base block (no power to Servomotor, servo is OFF)
<i>run</i>	Operating (power to Servomotor, servo is ON)
<i>Pot</i>	Forward rotation prohibited (POT (Forward rotation prohibited input) is OFF)
<i>not</i>	Reverse rotation prohibited (NOT (Reverse rotation prohibited input) is OFF)
<i>R□□</i>	Alarm display (Refer to alarm table.)
<i>nO OP</i>	Key operation disabled (When attempting to execute operations that cannot be performed in System Check Mode)
<i>Error</i>	Setting error (When a parameter setting is not suitable)

4-9-3 Monitor Mode (Un□□□)

■ Operations Using Monitor Mode

- After switching to Monitor Mode, set the monitor number, and press the DATA Key (front panel: DATA Key for 1 s min.) to display the monitor value.

● Switching to Monitor Mode

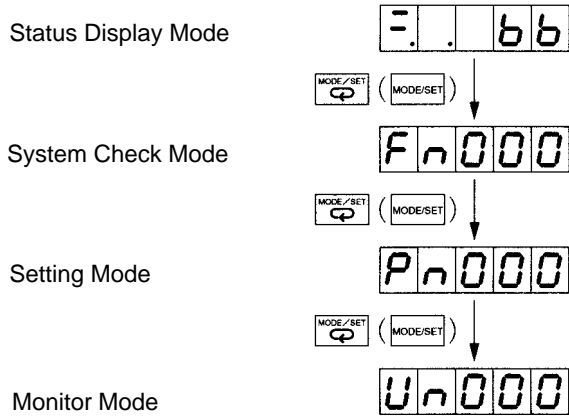

Note Switch to Monitor Mode (Un.□□□) using the MODE/SET Key.

● Operations in Monitor Mode

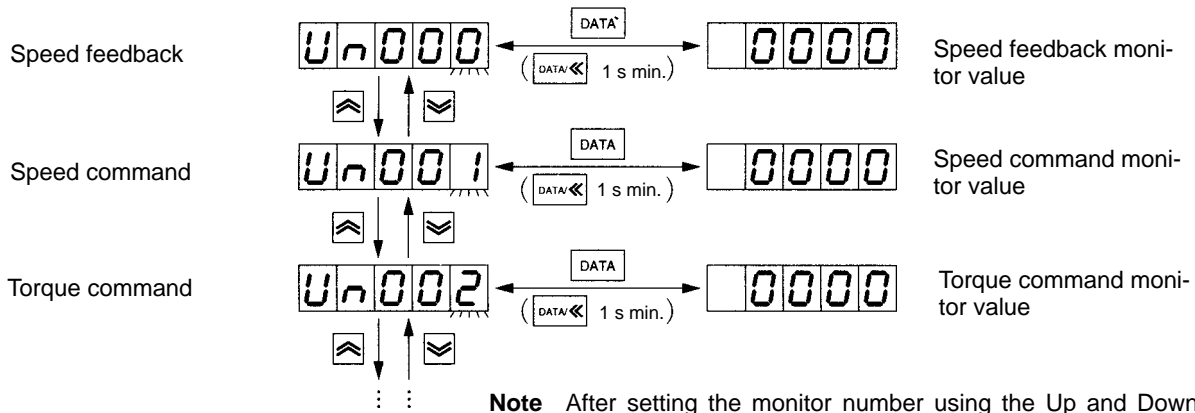

Note After setting the monitor number using the Up and Down Keys, press the DATA Key (front panel: DATA Key for 1 s min.) to display the monitor value. Press the Key again to return to the monitor number display.

Operating Procedure Example: Displaying Monitor Value of Electrical Angle (Un.004)

PR02W operation	Front panel key operation	Display	Explanation
			(Status Display Mode)
			Press the MODE SET Key to switch to Monitor Mode.
			Set monitor No. Un004 using the Up or Down Key. (See note.)
	 (1 s min.)		Press the DATA Key (front panel: DATA Key for 1 s min.) to display monitor value for Un004 (electrical angle).
	 (1 s min.)		Press the DATA Key (front panel: DATA Key for 1 s min.) to return to monitor number display.

Note Digits that can be manipulated will flash.

■ Types of Monitoring

- In Monitor Mode, 14 types of monitoring can be carried out.

Display (monitor No.)	Monitor contents	Unit	Explanation
U _n 000	Speed feedback (all output modes)	r/min	Displays actual rotation speed of Servomotor.
U _n 001	Speed command (speed)	r/min	Displays speed command voltage calculated in r/min.
U _n 002	Torque command (all output modes)	%	Displays command values to current loop (rated torque = 100%).
U _n 003	Number of pulses from Phase Z edge (all output modes)	Pulse	Displays rotation position from Phase Z edge (4X calculation).
U _n 004	Electrical angle (all output modes)	Degrees	Displays the electrical angle of the Servomotor.
U _n 005	Input signal monitor (all output modes)	---	Displays the control input signal status using ON/OFF bits.
U _n 006	Output signal monitor (all output modes)	---	Displays the control output signal status using ON/OFF bits.
U _n 007	Command pulse speed display (position)	r/min	Calculates and displays command pulse frequency in r/min.
U _n 008	Position deviation (deviation counter) (position)	Command	Displays the number of residual pulses in the deviation counter (input pulse standard). The display will change to "SA" if the deviation exceeds ± 9999.
U _n 009	Cumulative load ratio (all output modes)	%	Displays effective torque (rated torque = 100%, 10-s cycle).
U _n 00A	Regeneration load ratio (all output modes)	%	Displays regeneration absorption current due to regeneration resistance (calculates internal resistance capacity or Pn600 setting as 100% in 10-s cycles).
U _n 00b	Dynamic brake resistance load ratio (all output modes)	%	Displays current consumption during dynamic brake operation (calculates tolerance current consumption as 100% in 10-s cycles).
U _n 00C	Input pulse counter (position)	Command	Counts and displays input pulses (displayed in hexadecimal).
U _n 00d	Feedback pulse counter (all output modes)	Pulse	Counts and displays feedback pulse (4X calculation, displayed in hexadecimal).

• Input Signal Monitor Contents (Un005)

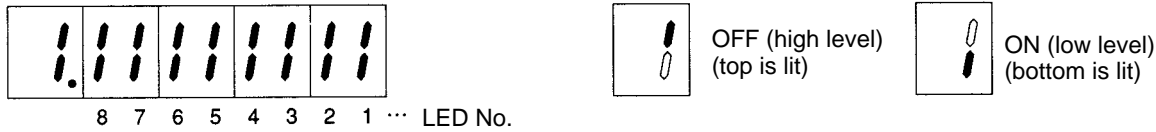

Indicator No.	Input terminal	Signal name (default)
1	CN1-40	RUN (RUN command)
2	CN1-41	MING (gain reduction), RDIR (rotation direction command), TVSEL (control mode switching), PLOCK (position lock command), IPG (pulses prohibited)
3	CN1-42	POT (forward rotation prohibited)
4	CN1-43	NOT (reverse rotation prohibited)
5	CN1-44	RESET (alarm reset)
6	CN1-45	PCL (forward rotation current limit), SPD1 (speed selection command 1)
7	CN1-46	NCL (reverse rotation current limit), SPD2 (speed selection command 2)
8	CN1-4	SEN (sensor ON)

Note 1. The vertical 7-segment LED is divided into two segments, upper and lower, which together comprise one pair to display the ON/OFF status of a single input signal. When an input signal is OFF (high level), the top LED is lit, and when the signal is ON (low level), the bottom LED is lit. When the SEN signal is ON (high level), the top LED is lit, and when the signal is OFF (low level), the bottom LED is lit.

Note 2. Refer to 4-4-3 *Important Parameters* for input signal allocation.

• Output Signal Monitor Contents (Un006)

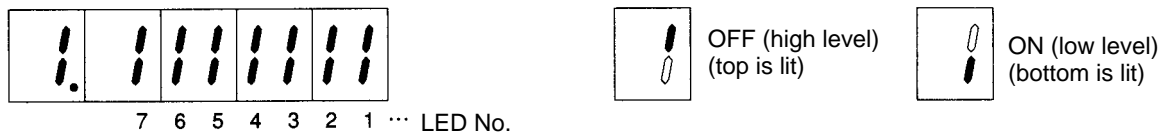

Indicator No.	Output terminal	Signal name (default)
1	CN1-31, 32	ALM (alarm)
2	CN1-25, 26	INP1 (positioning completed output 1), VCMP (speed conformity)
3	CN1-27, 28	TGON (Servomotor rotation detection)
4	CN1-29, 30	READY (servo ready)
5	CN1-37	ALO1 (alarm code output 1)
6	CN1-38	ALO2 (alarm code output 2)
7	CN1-39	ALO3 (alarm code output 3)

Note 1. The vertical 7-segment LED is divided into two segments, upper and lower, which together comprise one pair to display the ON/OFF status of a single output signal. When an output signal is OFF (high level), the top LED is lit, and when the signal is ON (low level), the bottom LED is lit.

Note 2. Refer to 4-4-3 *Important Parameters* for input signal allocation.

• Input Pulse Counter (Un00C) and Feedback Pulse Counter (Un00d) Contents

• Input Pulse Counter (Un00C) and Feedback Pulse Counter (Un00d) monitor values are displayed as 8-digit hexadecimal (32-bit string data).

- These monitor values can also be cleared (i.e., set to zero) in Monitor Mode.

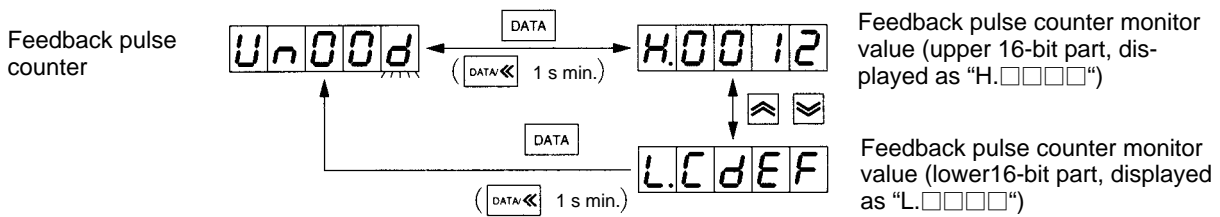

Operating Procedure Example: Feedback Pulse Counter (Un.00d) Monitor Value Display

PR02W operation	Front panel key operation	Display	Explanation
		Un000	(Monitor Mode)
⬆ ⬇	⬆ ⬇	Un00d	Set monitor No. Un004 using the Up or Down Key. (See note 1.)
DATA	DATA (1 s min.)	H.0012	Press the DATA Key (front panel: DATA Key for 1 s min.) to display upper 4 digits (16-bit part) as H.□□□□
⬆ ⬇	⬆ ⬇	L.CdEF	Press the Up or Down Key to display lower 4 digits (16-bit part) as L.□□□□
DATA	DATA (1 s min.)	Un00d	Press the DATA Key (front panel: DATA Key for 1 s min.) to return to monitor number display.

Note 1. Digits that can be manipulated will flash.

Note 2. Press Up and Down Keys simultaneously when the monitor value is displayed (i.e., "H.□□□□" or "L.□□□□" is displayed) to clear the counter (i.e., reset to H.0000 or L.0000).

4-10 Using Monitor Output

OMNUC W-series AC Servo Drivers output in analog form the Servomotor rotation speed, torque command, position difference, and other proportional voltage amounts from the Analog Monitor Output Connector (CN5). This function can be used in situations such as making fine gain adjustments or when a meter is attached to the control panel. Select the monitor items using user parameters Pn003.0 and Pn003.1. Also, use Fn00C and Fn00d in System Check Mode to adjust the offset and change the scaling.

■ Analog Monitor Output Connector (CN5)

- The Analog Monitor Output Connector (CN5) is located inside the top cover of the Servo Driver.

Note There is no top cover on models R88D-WT60H to R88D-WT150H (6 to 15 kW). Instead, CN5 is to the right of the display and settings area.

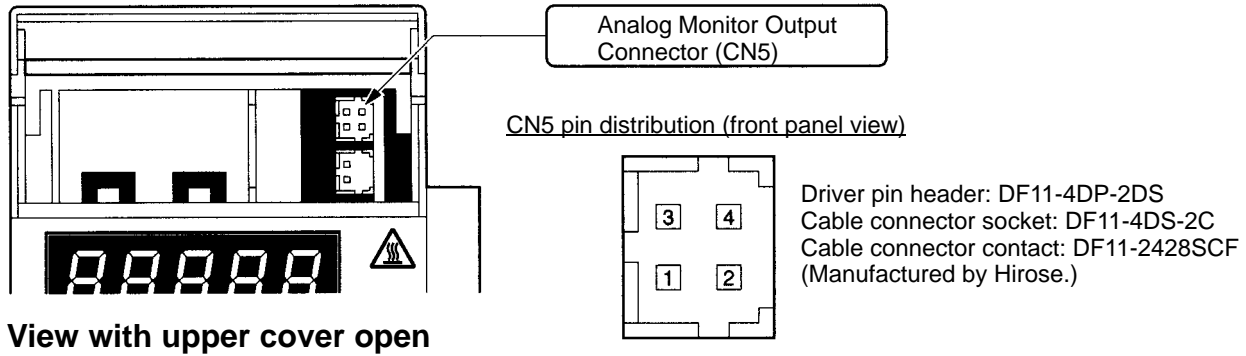

View with upper cover open

Pin No.	Symbol	Name	Function and interface
1	NM	Analog monitor 2	Default setting: Speed monitor 1 V / 1000 r/min. (change using Pn003.1)
2	AM	Analog monitor 1	Default setting: Current monitor 1 V / rated torque (change using Pn003.0)
3	GND	Analog monitor ground	Ground for analog monitors 1 and 2
4	GND	Analog monitor ground	

Note 1. Displays status with no change to scaling.

Note 2. Maximum output voltage is ± 8 V. Exceeding this value may result in an abnormal output.

Note 3. Output accuracy is approximately $\pm 15\%$.

■ Analog Monitor Output Circuit

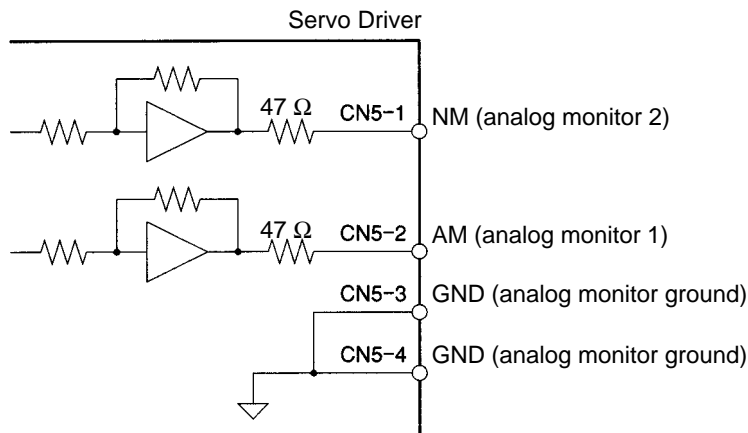

■ **Analog Monitor Cable (R88A-CMW001S)**

Use this cable to connect the Servo Driver's Analog Monitor Connector (CN5)

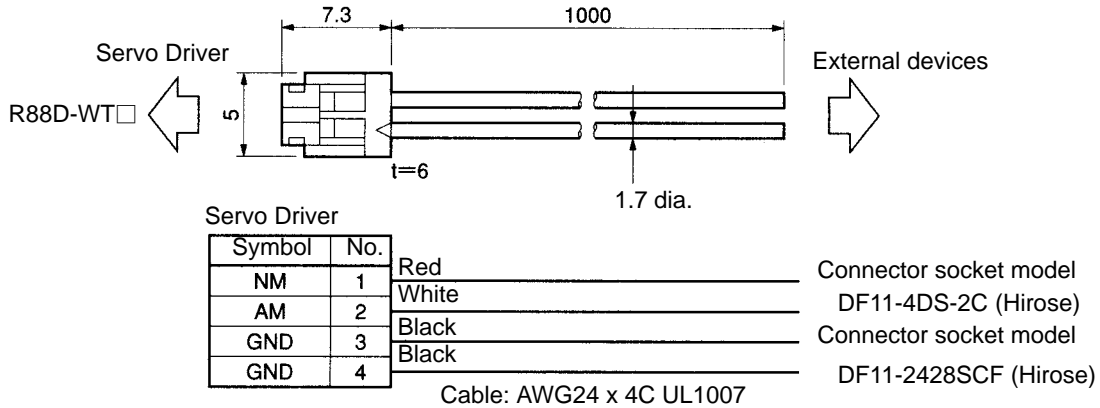

■ **Monitored Item Selection: User Parameter Function Application Switch 3 (Pn003: Default Setting 0002)**

Change the monitored item with user parameter Pn003 (function selection application switch 3).

Pn003.0	Function selection application switch 3: Analog monitor 1 (AM) allocation						
Setting range	0 to F	Unit	---	Default setting	2	Restart power?	No

Pn003.1	Function selection application switch 3: Analog monitor 2 (NM) allocation						
Setting range	0 to F	Unit	---	Default setting	0	Restart power?	No

Settings Explanation

Setting	Explanation
0	Servomotor rotation speed (speed monitor): 1 V/1000 r/min. Forward rotation: – voltage, reverse rotation: + voltage. All operation modes
1	Speed command: 1 V/1000 r/min. Forward rotation command: – voltage, reverse rotation command: + voltage. Position, speed, internally-set speed control
2	Torque command (current monitor): 1 V/rated torque, forward acceleration: – voltage, reverse acceleration: + voltage. All operation modes
3	Position deviation: 0.05 V/1 command. Plus deviation: – voltage, minus deviation: + voltage. Position
4	Position deviation: 0.05 V/100 commands. Plus deviation: – voltage, minus deviation: + voltage. Position
5	Command pulse frequency: 1 V/1000 r/min. Forward rotation: – voltage, reverse rotation: + voltage. Position
6	Servomotor rotation speed (speed monitor): 1 V/250 r/min., Forward rotation: – voltage, reverse rotation: + voltage. All operation modes
7	Servomotor rotation speed (speed monitor): 1 V/125 r/min., Forward rotation: – voltage, reverse rotation: + voltage. All operation modes
8 to F	Not used.

- Set values are the same as for Pn003.0 and Pn003.1.

Note Displays status without offset adjustment and scaling changes.

■ **Analog Monitor Output Adjustment: System Check Mode Offset Adjustment (Fn00C), Scaling (Fn00d)**

- The following two types of analog monitor output adjustment can be performed using System Check Mode.
 - Analog monitor output offset manual adjustment (Fn00C).
 - Analog monitor output scaling (Fn00d)

Note Refer to 4-11-6 *Analog Monitor Output Adjustment* for details of adjustment and operation methods.

4-11 System Check Mode

■ **System Check Mode Functions**

- Refer to the relevant pages for an explanation of System Check Mode (Fn□□□) and other functions.

Display (function code)	Function name	Reference
<i>Fn000</i>	Alarm history display: Displays the last 10 alarms to occur.	<i>4-11-1 Alarm history</i>
<i>Fn001</i>	Rigidity setting during online auto-tuning: Sets the control target during online auto-tuning.	<i>4-11-2 Online Auto-tuning Related Functions</i>
<i>Fn002</i>	Jog operation	<i>4-3-2 Jog Operation</i>
<i>Fn003</i>	Servomotor origin search: Fix the position of the Servomotor origin pulse (Phase Z) using a key operation.	<i>4-11-3 Servomotor Origin Search</i>
<i>Fn005</i>	User parameter initialization: Restores user parameters to their default settings.	<i>4-11-4 User Parameter Initialization</i>
<i>Fn006</i>	Alarm history data clear	<i>4-11-1 Alarm history</i>
<i>Fn007</i>	Store online auto-tuning results: Writes the load data calculated using online auto-tuning to Pn103 (inertia ratio).	<i>4-11-2 Online Auto-tuning Related Functions</i>
<i>Fn008</i>	Absolute encoder setup (ABS)	<i>4-2-2 Absolute Encoder Setup and Battery Changes</i>
<i>Fn009</i>	Speed and torque command offset automatic adjustment	<i>4-11-5 Command Offset Adjustment</i>
<i>Fn00A</i>	Speed command offset manual adjustment	
<i>Fn00b</i>	Torque command offset manual adjustment	
<i>Fn00C</i>	Analog monitor output offset manual adjustment	<i>4-11-6 Analog Monitor Output Adjustment</i>
<i>Fn00d</i>	Analog monitor output scaling: You can change the analog monitor output scaling within a range of 50% to 150%.	
<i>Fn00E</i>	Servomotor current detection offset automatic adjustment	<i>4-11-7 Servomotor Current Detection Offset Adjustment</i>
<i>Fn00F</i>	Servomotor current detection offset manual adjustment	
<i>Fn010</i>	Password setting: You can permit or prohibit writing to user parameters.	<i>4-11-8 Password Setting</i>
<i>Fn011</i>	Servomotor parameter check: Check the types of connected Servomotors and encoders.	<i>4-11-9 Checking Servomotor Parameters</i>
<i>Fn012</i>	Version check: Check the Servo Driver and encoder software versions.	<i>4-11-10 Checking Version</i>

Display (function code)	Function name	Reference
F _n 013	Absolute encoder multi-turn setting (ABS) change: If you change user parameter setting Pn205 (absolute encoder multi-turn limit setting), the new value is automatically written to the encoder.	4-11-11 Changing Absolute Encoder Rotation Setting
F _n 014	Option Unit detection results clear: If an Option Unit is removed, an A.E7 alarm (option detection error) will be detected. Use this function to clear the Option Unit detection results.	4-11-12 Clearing Option Unit Detection Results

4-11-1 Alarm History

- OMNUC W-series AC Servo Drivers remember up to the last 10 alarms to have occurred. This section explains the alarm history data display (Fn000) and how to clear the data (Fn006).

■ Alarm History Display (Fn000)

- Display the remembered alarms using System Check Mode (Fn000).

Note 1. Alarms CPF00 (Parameter Unit transmission error 1) and CPF01 (Parameter Unit transmission error 2) are Parameter Unit alarms, and so are not stored in the alarm history.

Note 2. Warnings are not stored in the alarm history.

Note 3. If the same alarm occurs continuously, it is entered in the alarm history only as a single alarm.

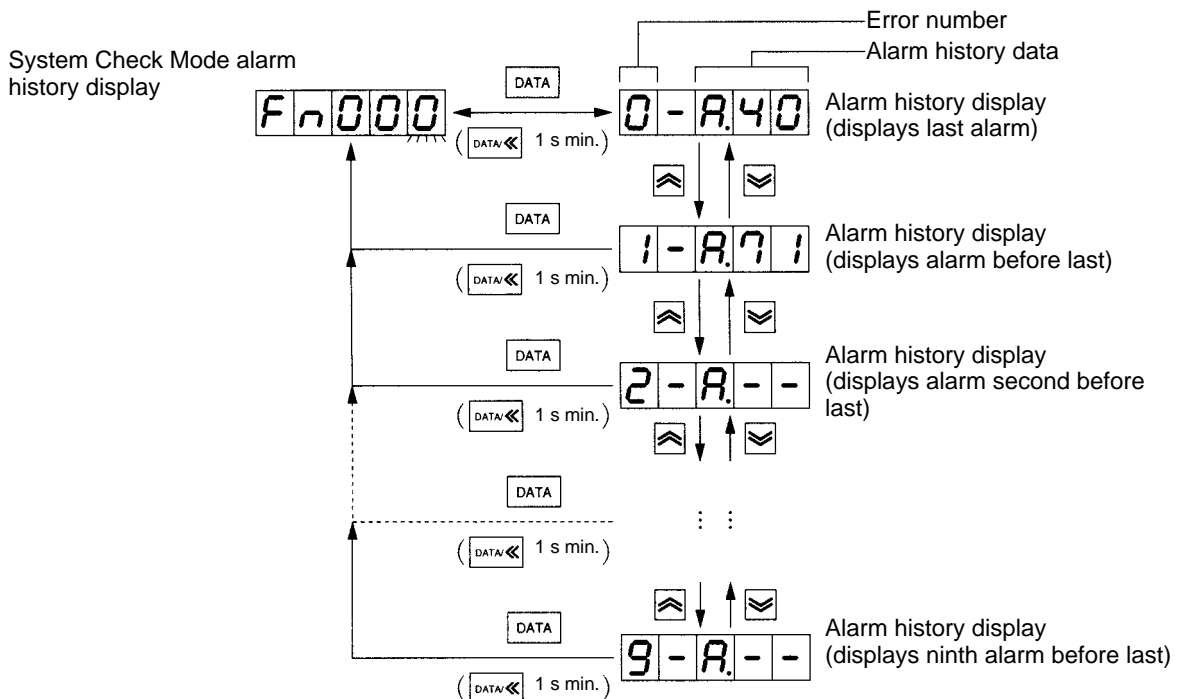

Operation Procedure

PR02W operation	Front panel key operation	Display	Explanation
			Press the MODE/SET Key to change to System Check Mode. If a function code other than Fn000 is displayed, press the Up or Down Key to set function code Fn000. (See note 1.)
			Press the DATA Key (front panel: DATA Key for 1 s min.). The last alarm will be displayed.
			Press the Up Key to display the alarm before the alarm currently displayed. (See note 2.)
			Press the Up Key to display the alarms in order of occurrence. (See note 3.)
			Press DATA Key (front panel: DATA Key for 1 s min.) to end displaying the alarm history and return to the function code display.

- Note 1.** The digits you can manipulate will flash.
- Note 2.** The larger the error number, the older the alarm.
- Note 3.** The display “A--” indicates no alarm.

■ Alarm History Data Clear (Fn006)

- Use the alarm history data clear (Fn006) to clear all the alarm history in memory.

Note When you clear the alarm log data, the alarm history display for all alarms will change to “□-A.--.”

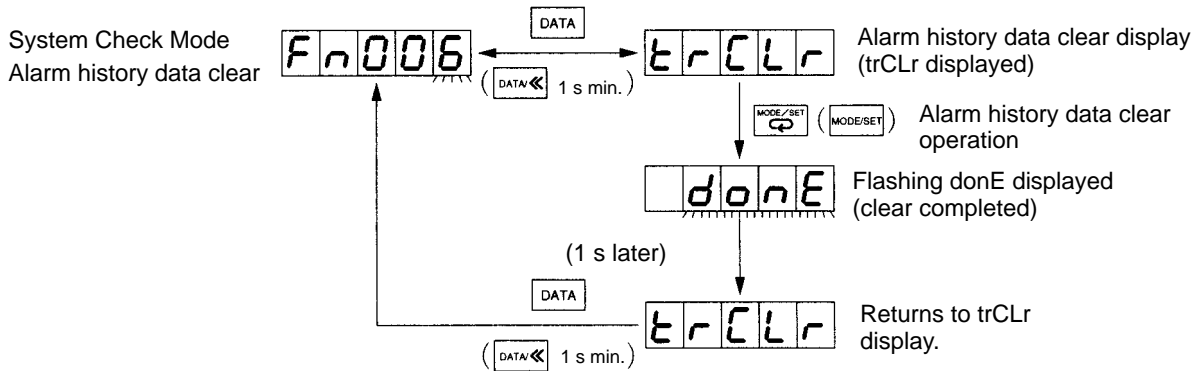

Operation Procedure

PR02W operation	Front panel key operation	Display	Explanation
			Press the MODE/SET Key to change to System Check Mode.
			Press the Up or Down Key to set function code Fn006. (See note.)
			Press DATA Key (front panel: DATA Key for 1 s min.) to display "trCLr."
			Press the MODE/SET Key to clear the alarm history data. When the data has been cleared, "donE" will flash for approximately 1 s.
(Approx. 1 s later)			After "donE" has been displayed, the display will return to "trCLr."
			Press the DATA Key (front panel: DATA Key for 1 s min.). The display will return to the System Check Mode function code.

Note The digits you can manipulate will flash.

4-11-2 Online Auto-tuning Functions

- In System Check Mode, online auto-tuning consists of the rigidity setting (Fn001) and saving tuning results (Fn007).

■ Rigidity Setting During Online Auto-tuning (Fn001)

- The rigidity setting during online auto-tuning sets the target speed loop gain and position loop gain for the servo system.
- Select the rigidity setting according to the following 10 levels for the mechanical system.

Rigidity setting Fn001 (d.00□□)	Position loop gain [s ⁻¹] Pn102	Speed loop gain [Hz] Pn100	Speed loop integration time constant [x 0.01 ms] Pn101	Torque command filter time constant [x 0.01 ms] Pn401
01	15	15	6000	250
02	20	20	4500	200
03	30	30	3000	130
04	40	40	2000	100
05	60	60	1500	70
06	85	85	1000	50
07	120	120	800	30
08	160	160	600	20
09	200	200	500	15
10	250	250	400	10

Note 1. The higher the rigidity setting, the higher the servo system loop gain, and the shorter the positioning time. If the set value is too high, however, the machinery may vibrate. If vibration occurs, lower the setting.

Note 2. When you set the rigidity, the user parameters given in the above table will change automatically.

Note 3. If you enable auto-tuning without setting the rigidity, tuning is performed using the user parameter settings (Pn102, Pn100, Pn101, and Pn401) as the target values.

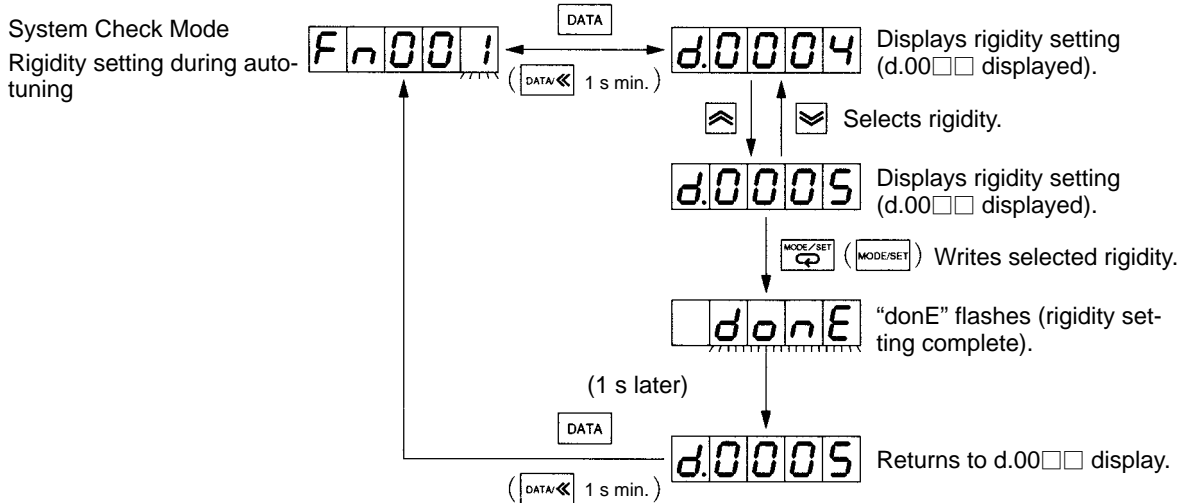

Operation Procedure

PR02W operation	Front panel key operation	Display	Explanation
		Fn001	Press the MODE/SET Key to change to System Check Mode.
		Fn001	Press the Up or Down Key to set function code Fn001. (See note.)
DATA	DATA (1 s min.)	d.0004	Press DATA Key (front panel: DATA Key for 1 s min.) to display "d.00□□."
		d.0005	Press the Up or Down Key to select the rigidity.
		donE	Press the MODE/SET Key to set the rigidity. When rigidity setting is completed, "donE" will flash for approximately 1 s.
(Approx. 1 s later)		d.0005	After "donE" has been displayed, the display will return to "d.00□□."
DATA	DATA (1 s min.)	Fn001	Press the DATA Key (front panel: DATA Key for 1 s min.). The display will return to the System Check Mode function code.

Note The digits you can manipulate will flash.

■ **Storing Online Auto-tuning Results (Fn007)**

- Online auto-tuning constantly calculates and refreshes the load inertia using the rigidity settings (speed loop gain, position loop gain, etc.) as target values. When the power supply is turned OFF after operations are complete, however, the calculated data is lost, and the next time the power supply is turned ON, calculations will restart using Pn103 (inertia ratio) setting as the initial value.

- Store the online auto-tuning results if you want to use the results as the initial value when the power supply is next turned ON again. Performing this operation writes the results to Pn103 (inertia ratio).

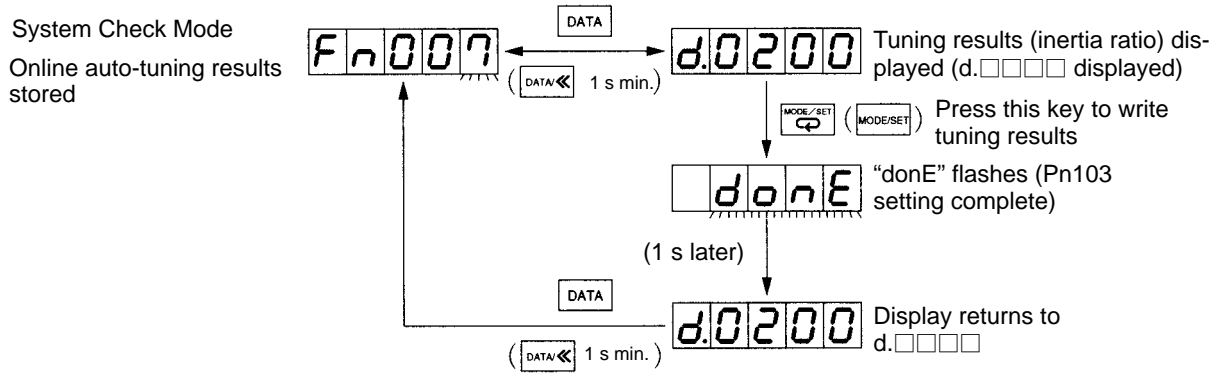

Operation Procedure

PR02W operation	Front panel key operation	Display	Explanation
			Press the MODE/SET Key to change to System Check Mode.
			Press the Up or Down Key to set function code Fn007. (See note 1.)
			Press the DATA Key (front panel: DATA Key for 1 s min.) to display "d.□□□□." (See note 2.)
			Press the MODE/SET Key to write the tuning results to Pn103 (inertia ratio). When writing is complete, "donE" will flash for approximately 1 s.
(Approx. 1 s later)			After "donE" has been displayed, the display will return to "d.□□□□."
			Press the DATA Key (front panel: DATA Key for 1 s min.). The display will return to the System Check Mode function code.

Note 1. The digits you can manipulate will flash.

Note 2. "□□□□" denotes the inertia ratio (%) calculated by online auto-tuning. (The example given shows a display of 200%).

4-11-3 Servomotor Origin Search

■ **Servomotor Origin Search (Fn003)**

- The Servomotor origin search function rotates the Servomotor to the encoder's origin pulse (phase Z) position, and then stops the Servomotor.
- Use this function to adjust the origin position of the Servomotor shaft and mechanical system.

Note 1. Execute the Servomotor origin search before connecting the Servomotor shaft and mechanical system.

Note 2. The RUN command input must be turned OFF. Also, if the RUN signal is set to be always ON (Pn50A.1 = 7), either change the setting to "Always OFF" (setting value: 8) or change the setting to another value, then turn OFF the power supply once, and then turn it ON again.

Note 3. While the Servomotor origin search is being executed, the POT (forward drive prohibited) and NOT (reverse drive prohibited) inputs are disabled.

Note 4. The Servomotor origin search rotation speed is 60 r/min.

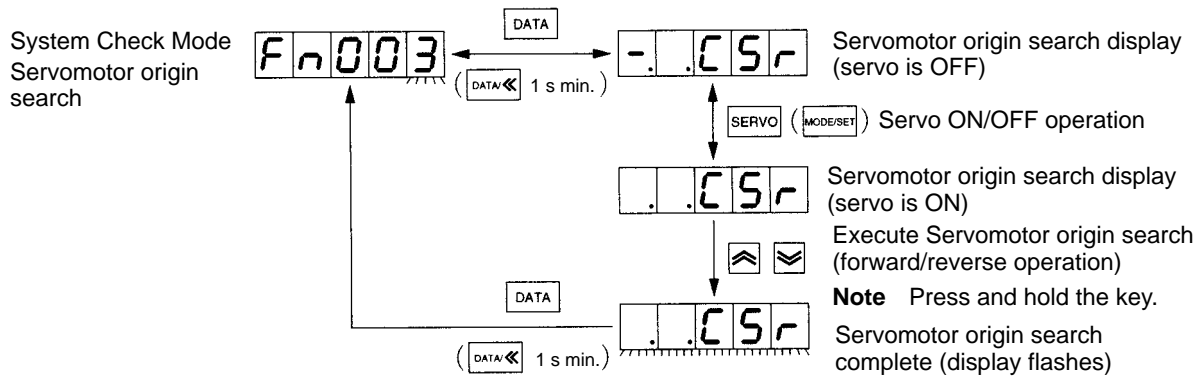

Operation Procedure

PR02W operation	Front panel key operation	Display	Explanation
			Press the MODE/SET Key to change to System Check Mode.
			Press the Up or Down Key to set function code Fn003. (See note.)
			Press the DATA Key (front panel: DATA Key for 1 s min.) to display Servomotor origin search.
			Turn ON the servo.
			Press the Up Key to rotate the Servomotor forwards, and press the Down Key to rotate the Servomotor in reverse. The Servomotor will rotate at 60 r/min. while the Key is being pressed.
(Servomotor origin search complete)			When Servomotor origin search is completed, the display will flash, and the Servomotor will servolock at the origin pulse position.
			Press the DATA Key (front panel: DATA Key for 1 s min.). The display will return to the System Check Mode function code, and the Servomotor servo will turn OFF.

Note The digits you can manipulate will flash.

4-11-4 User Parameter Initialization

■ User Parameter Initialization (Fn005)

- Initialize the user parameters to return the user parameters to the default settings.

Note 1. You cannot perform initialization while the servo is ON. First turn OFF the servo, then perform the operation.

Note 2. After initializing the user parameters, turn OFF the power supply (confirm that the power supply indicator is not lit), then turn ON the power once again to enable the parameters.

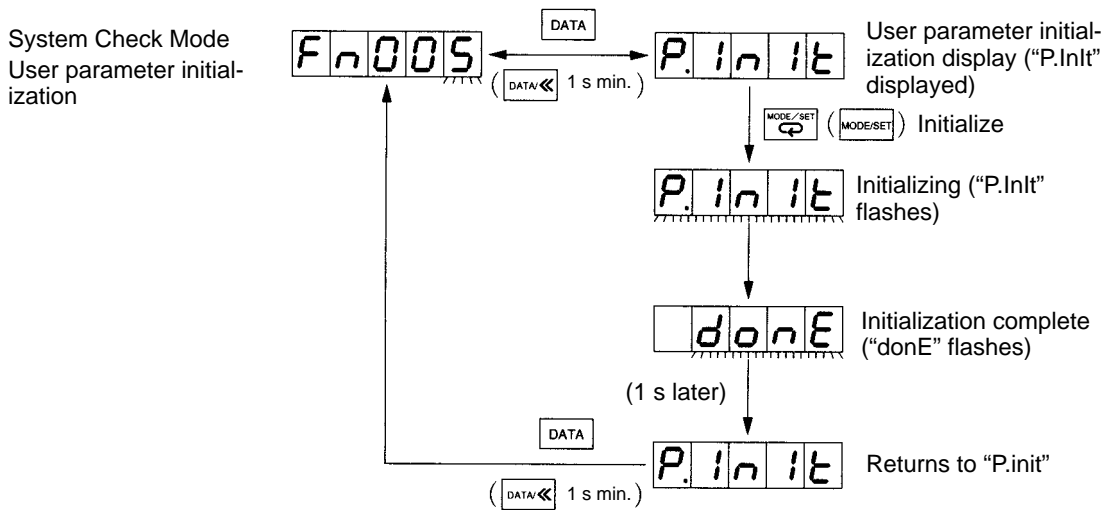

Operation Procedure

PR02W operation	Front panel key operation	Display	Explanation
			Press the MODE/SET Key to change to System Check Mode.
			Press the Up or Down Key to set function code Fn005. (See note.)
			Press the DATA Key (front panel: DATA Key for 1 s min.) to display user parameter initialization.
			Press the MODE/SET Key to start user parameter initialization. During initialization, "P.InIt" will flash.
(After initialization)			The display "donE" will flash for about 1 second when the user parameter initialization has been completed.
(Approx. 1 s later)			After displaying "donE," the display will return to "P.InIt."
			Press the DATA Key (front panel: DATA Key for 1 s min.). The display will return to the System Check Mode function code.

Note The digits you can manipulate will flash.

4-11-5 Command Offset Adjustment

- When operating in the Speed Control and Torque Control Modes, the Servomotor may rotate slightly even if an analog command voltage of 0 V (command value zero) is input. This is due to small offset amounts (in the order of mV) in the Host Controller and external circuits command voltage.
- If using speed control or torque command control, be sure to adjust the offset to zero.
- Use one of the following methods to adjust the command offset.
 - Speed and torque command offset automatic adjustment (Fn009)
 - Speed command offset manual adjustment (Fn00A) and torque command offset manual adjustment (Fn00b).

■ Speed and Torque Command Offset Manual Adjustment (Fn009)

- This function adjusts automatically both the speed command and torque command.
- When the offset is adjusted, the offset amount is stored in internal driver memory. You can also check this offset amount using manual adjustment (Fn00A or Fn00b).

Note Make sure the servo is turned OFF before performing speed and torque command offset automatic adjustment. Consequently, you cannot use automatic adjustment with a status that includes position loop using the Host Controller (i.e., when the servo is ON). Use manual adjustment if you want to adjust the deviation pulse to zero when the servolock is ON and includes a position loop using the Host Controller.

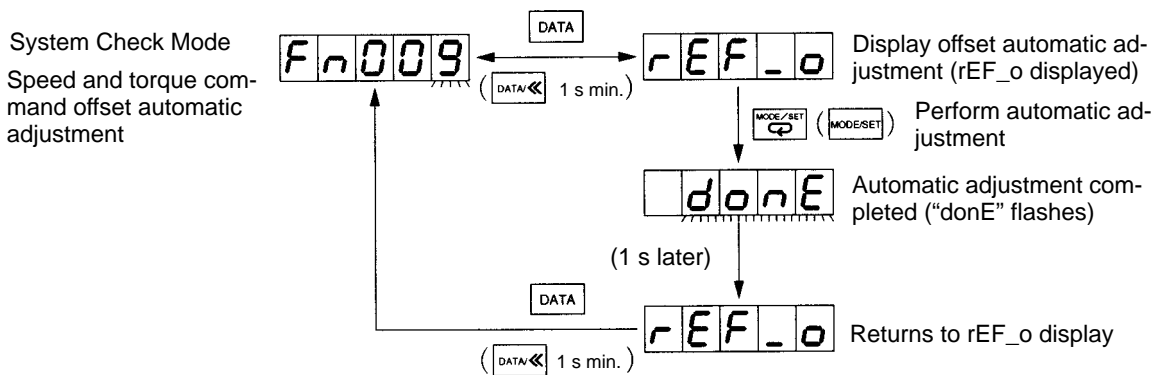

Operation Procedure

PR02W operation	Front panel key operation	Display	Explanation
			Press the MODE/SET Key to change to System Check Mode.
			Press the Up or Down Key to set function code Fn009. (See note.)
			Press the DATA Key (front panel: DATA Key for 1 s min.) to display "rEF_o."
(Input command = 0)			Input speed and torque commands "command = 0" from either the Host Controller or the external circuits. (Make sure that RUN is turned OFF.)
			Press the MODE/SET Key to perform automatic offset adjustment. When automatic adjustment is complete, "donE" flashes for approximately 1 s.
(Approx. 1 s later)			After displaying "donE," the display will return to "rEF_o."
			Press the DATA Key (front panel: DATA Key for 1 s min.). The display will return to the System Check Mode function code.

Note The digits you can manipulate will flash.







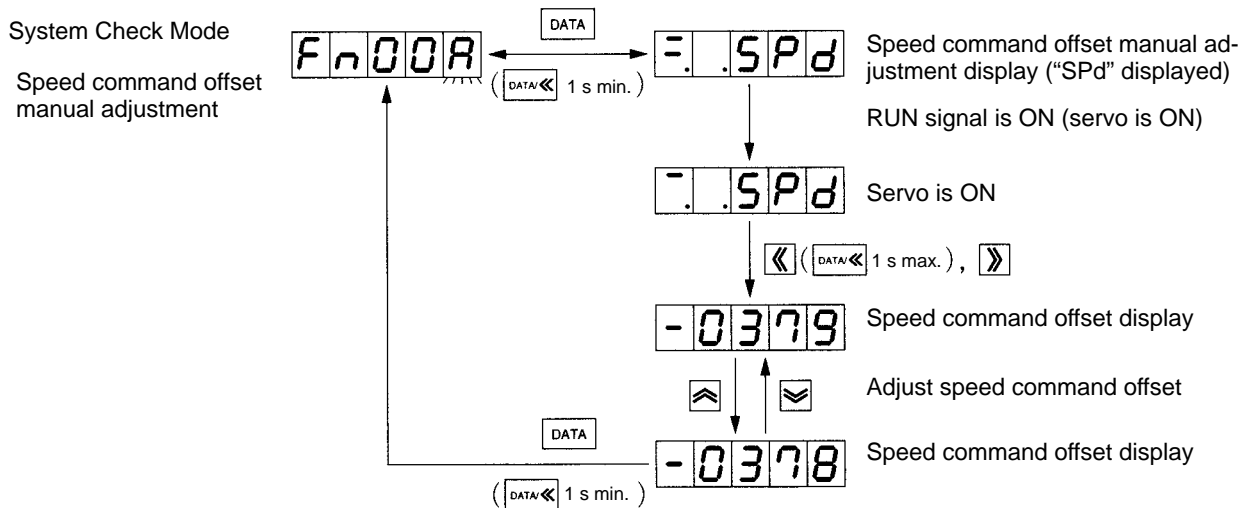



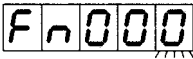

■ Speed Command Offset Manual Adjustment (Fn00A)

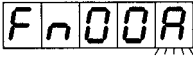
- Use manual adjustment for adjusting deviation pulses (the deviation counter value in the host controller) to zero while servo-locked, with a position loop incorporated by the host controller.
- Perform manual adjustment while checking the deviation counter value or the Servomotor shaft movement while the RUN signal is ON.
- The speed command offset setting range is -9999 to 9999 (x 0.058 mV).

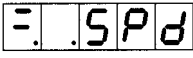
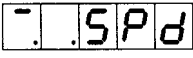
Note Manually adjust the speed command offset using Speed Control Mode.

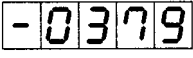

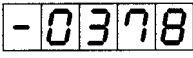
Operation Procedure

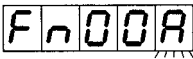
PR02W operation	Front panel key operation	Display	Explanation
			Press the MODE/SET Key to change to System Check Mode.
			Press the Up or Down Key to set function code Fn00A. (See note 1.)
	 (1 s min.)		Press the DATA Key (front panel: DATA Key for 1 s min.) to display "SPd."
Input command = 0, servo ON)			Input speed command "command = 0" from either the Host Controller or the external circuits, and make sure that RUN is ON. (See note 2.)
	 (1 s max.)		Press the Left Key (front panel: DATA Key for less than 1 s) or Right Key to display the offset amount. (See note 3.)
			Press the Up or Down Key to change the offset amount. Adjust the offset until the Servomotor stops. (See note 4.)
	 (1 s min.)		After completing offset adjustment, press the DATA Key (front panel: DATA Key for 1 s min.). The display will return to the System Check Mode function code.

Note 1. The digits you can manipulate will flash.

Note 2. Make sure that the servolock is ON if a position loop is incorporated by the host controller.

Note 3. The offset amount unit is x 0.058 mV.

Note 4. If a position loop is incorporated by the host controller, adjust until the host controller deviation counter value is zero.

■ Torque Command Offset Manual Adjustment (Fn00b)

- Adjust the torque command manually while checking the Servomotor shaft movement with the RUN signal ON.
- The torque command offset setting range is -9,999 to 9,999 (x 0.0058 mV).
(For Servo Drivers with software version r.0014 or earlier, the torque command offset setting range is -128 to 127 (x 14.7 mV).)

Note Adjust the torque command offset manually using torque command mode.

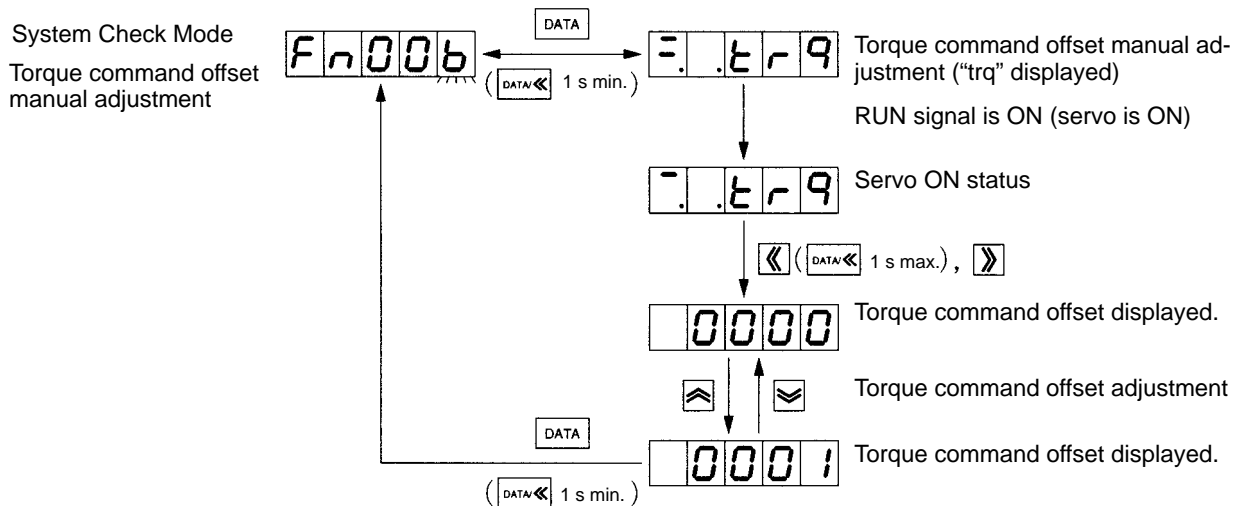

Operation Procedure

PR02W operation	Front panel key operation	Display	Explanation
			Press the MODE/SET Key to change to System Check Mode.
			Press the Up or Down Key to set function code Fn00b. (See note 1.)
			Press the DATA Key (front panel: DATA Key for 1 s min.) to display "trq."
Input command = 0, servo ON)			Input torque command "command = 0" from either the Host Controller or the external circuits, and make sure that RUN is ON.
			Press the Left Key (front panel: DATA Key for less than 1 s) or Right Key to display the offset amount. (See note 2.)
			Press the Up or Down Key to change the offset amount. Adjust the offset until the Servomotor stops. (See note 3.)
			After completing offset adjustment, press the DATA Key (front panel: DATA Key for 1 s min.). The display will return to the System Check Mode function code.

Note 1. The digits you can manipulate will flash.

Note 2. The offset amount unit is x 14.7 mV.

Note 3. Check the offset amount to stop the Servomotor in both forward direction and reverse direction, and then set the center value accordingly.

4-11-6 Analog Monitor Output Adjustment

- The following two types of analog monitor output adjustment can be performed using System Check Mode.
 - Analog monitor output offset manual adjustment (Fn00C).
 - Analog monitor output scaling (Fn00d)

Note 1. Set the monitor items to be output from the analog monitor using Pn003.0 (analog monitor 1 (AM) allocation), and Pn003.1 (analog monitor 2 (NM) allocation).

Note 2. The maximum analog monitor output voltage is ± 8 V. Exceeding this value may result in an abnormal output.

Note 3. Analog monitor output accuracy is approximately $\pm 15\%$

■ Analog Monitor Output Offset Manual Adjustment (Fn00C)

- Use this function to adjust the analog output monitor offset. You can adjust each of the two monitor outputs separately.
- The analog monitor output offset adjustment range is -128 to 127 (x 17 mV).

Note When adjusting the analog monitor output offset, confirm that the output voltage is zero (e.g., if outputting the Servomotor rotation speed, confirm that the servo is OFF and the Servomotor shaft is not moving) before connecting the measuring instrument to be used.

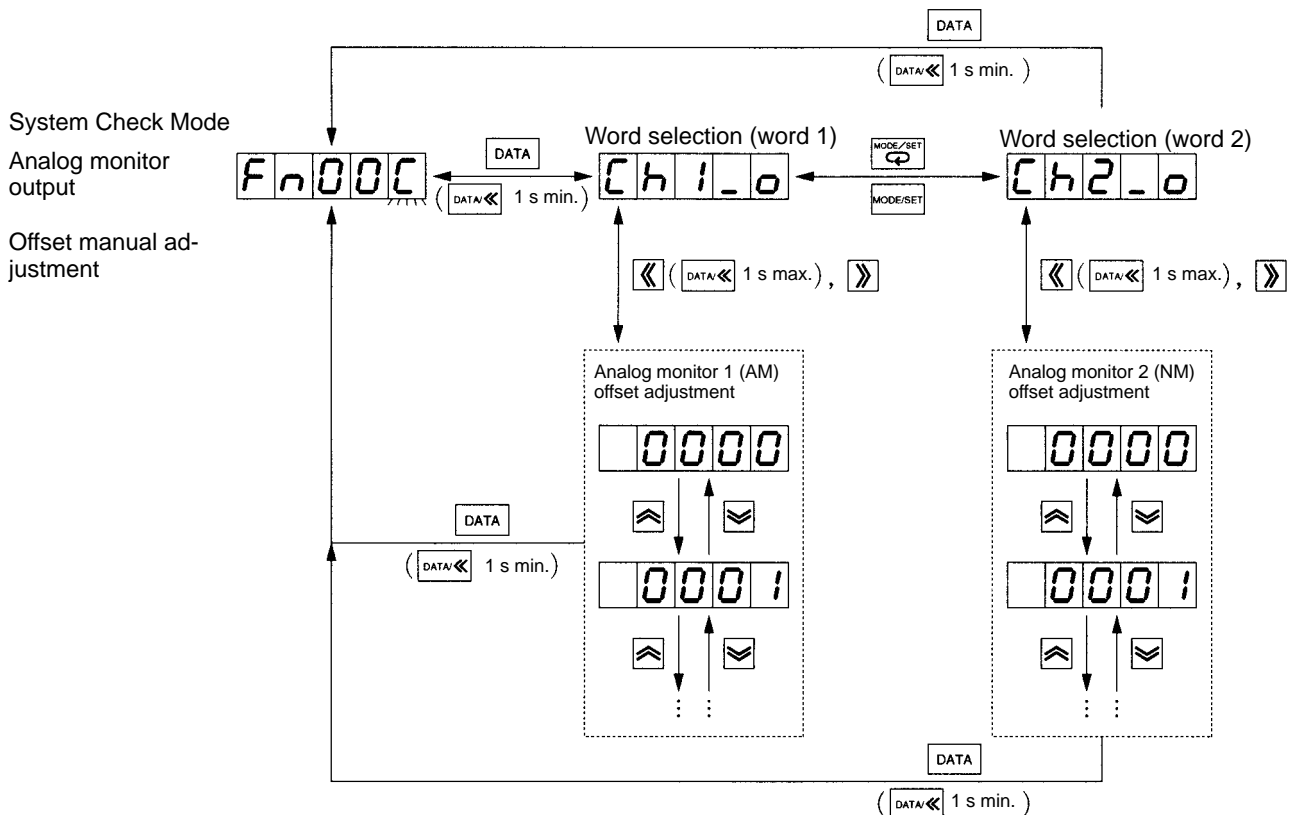

Operation Procedure

PR02W operation	Front panel key operation	Display	Explanation
			Press the MODE/SET Key to change to System Check Mode.
			Press the Up or Down Key to set function code Fn00C. (See note 1.)
	 (1 s min.)		Press the DATA Key (front panel: DATA Key for 1 s min.) to display "Ch1_o" (for analog monitor output 1 (AM)). (See note 2.)
	 (1 s max.)		Press the Left Key (front panel: DATA Key for less than 1 s) or Right Key to display the analog monitor output 1 (AM) offset amount. (See note 3.)
			Press the Up or Down Key to change the offset amount. Adjust the measuring device measurement value to 0 V.
	 (1 s max.)		After completing adjustments for analog monitor 1, press the Left Key (front panel: DATA Key for less than 1 s) or Right Key to return to the "Ch1_o" display.
			Press the MODE/SET Key to display "Ch2_o."
	 (1 s max.)		Press the Left Key (front panel: DATA Key for less than 1 s) or Right Key to display the analog monitor output 2 (NM) offset amount. (See note 3.)
			Press the Up or Down Key to change the offset amount. Adjust the measuring device measurement value to 0 V, the same as for analog output monitor 1.
	 (1 s min.)		After completing adjustments for analog monitor 2, press the DATA Key (front panel: DATA Key for 1 s min.). The display will return to the System Check Mode function code.

Note 1. The digits you can manipulate will flash.

Note 2. Press the MODE SET Key in this mode to display "Ch2_o," then select analog monitor output 2 (NM). Press the same Key again to return to "Ch1_o" display.

Note 3. The offset amount unit is x 17 mV.

■ Analog Monitor Output Scaling (Fn00d)

- Use this function to set the analog monitor output scale. You can set the two monitor outputs separately.
- The analog monitor output scale setting range is -128 to 127 ($\times 0.4\%$).
- Perform the scale setting as the center value of 100% . For example, if you set -125 , $100\% - (125 \times 0.4\%) = 50\%$, so the monitor output voltage = $1/2$. Alternatively, if you set 125 , $100\% = (125 \times 0.4\%) = 150\%$, so the monitor output voltage = $\times 1.5$.
- Make the setting in accordance with the measuring device input range.
- At a setting of 100% , if the analog monitor output voltage exceeds ± 8 V, you can adjust the output range to normal (i.e., within ± 8 V) by setting the scale to a negative number.

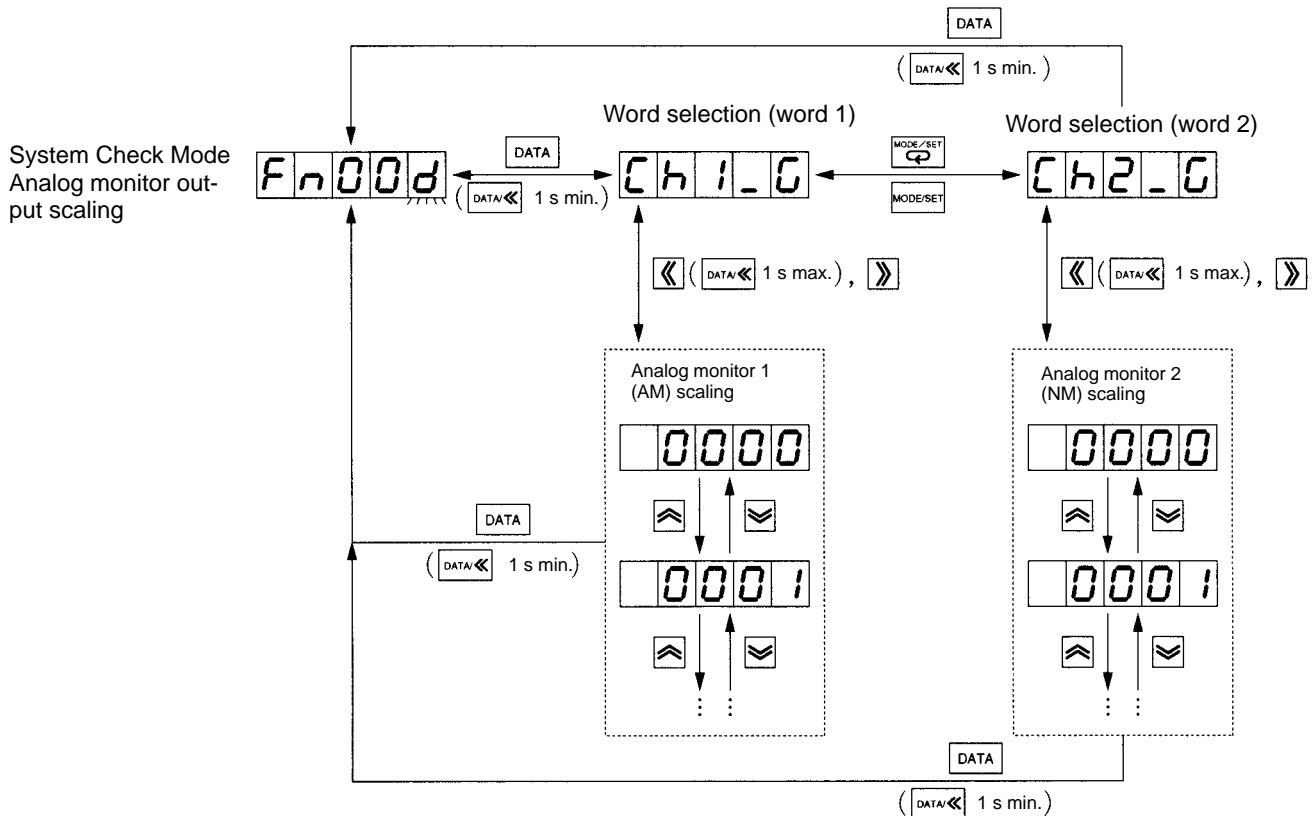

Operation Procedure

PR02W operation	Front panel key operation	Display	Explanation
			Press the MODE/SET Key to change to System Check Mode.
			Press the Up or Down Key to set function code Fn00d. (See note 1.)
			Press the DATA Key (front panel: DATA Key for 1 s min.) to display "Ch1_G" (for analog monitor output 1 (AM)). (See note 2.)
			Press the Left Key (front panel: DATA Key for less than 1 s) or Right Key to display the analog monitor output 1 (AM) offset amount. (See note 3.)
			Press the Up or Down Key to change the scale. Set the scale according to the measuring device input range.
			After completing adjustments for analog monitor 1, press the Left Key (front panel: DATA Key for less than 1 s) or Right Key to return to the "Ch1_G" display.
			Press the MODE/SET Key to display "Ch2_G."
			Press the Left Key (front panel: DATA Key for less than 1 s) or Right Key to display the analog monitor output 2 (NM) scale setting. (See note 3.)
			Press the Up or Down Key to change the scale. Set the scale according to the measuring device input range, the same as for analog output monitor 1.
			After completing adjustments for analog monitor 2, press the DATA Key (front panel: DATA Key for 1 s min.). The display will return to the System Check Mode function code.

Note 1. The digits you can manipulate will flash.

Note 2. Press the MODE/SET Key in this mode to display "Ch2_G," then select analog monitor output 2 (NM). Press the same Key again to return to "Ch1_G" display.

Note 3. The scale unit is x 0.4%.

4-11-7 Servomotor Current Detection Offset Adjustment

- Servomotor current detection offset adjustment has already been completed at the factory. Consequently, there is normally no need to perform adjustments.
- If you think that the torque ripple caused by current detection offset is abnormally large, perform Servomotor current detection offset automatic adjustment (Fn00E).
- After performing automatic adjustment, perform manual adjustment (Fn00F) if you still want to lower the torque ripple even further. If manual adjustment is performed badly, however, there is a risk of worsening the characteristics.

■ Servomotor Current Detection Offset Automatic Adjustment (Fn00E)

- Perform automatic adjustment to the Servomotor current detection offset.

Note Automatic adjustment can be performed only when the power supply to the main circuits is turned ON, and the power supply to the servo is OFF.

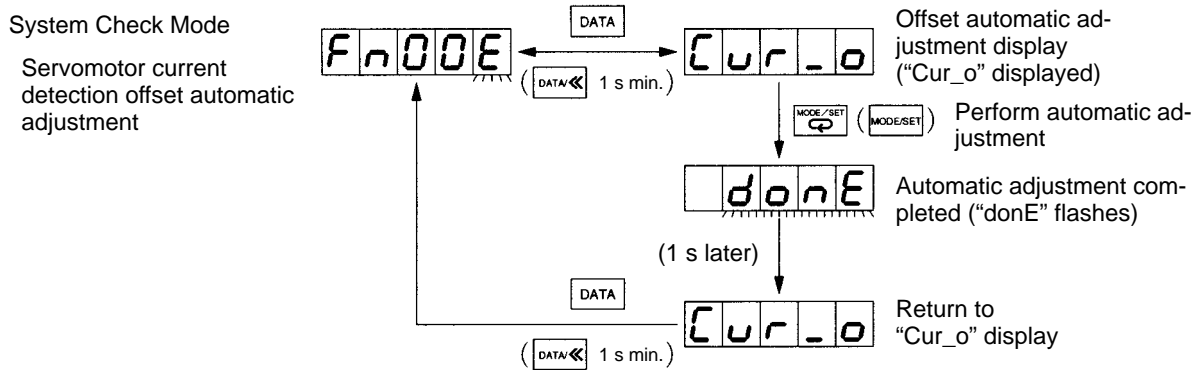

Operation Procedure

PR02W operation	Front panel key operation	Display	Explanation
		F n 0 0 0	Press the MODE/SET Key to change to System Check Mode.
		F n 0 0 E	Press the Up or Down Key to set function code Fn00E. (See note.)
DATA	DATA (1 s min.)	C u r _ o	Press the DATA Key (front panel: DATA Key for 1 s min.) to display "Cur_o".
		d o n E	Press the MODE/SET Key to perform automatic offset adjustment. When automatic adjustment is completed, "donE" will be displayed for approximately 1 s.
(Approx. 1 s later)		C u r _ o	After "donE" has been displayed, the display will return to "Cur_o."
DATA	DATA (1 s min.)	F n 0 0 E	Press the DATA Key (front panel: DATA Key for 1 s min.) to return to the System Check Mode function code display.

Note The digits you can manipulate will flash.

■ **Servomotor Current Detection Offset Manual Adjustment (Fn00F)**

- This function manually adjusts the Servomotor current detection offset.
- Adjust the U-phase and V-phase offsets alternately while balancing each separately.
- When performing adjustments, rotate the Servomotor at 100 r/min. without connecting the mechanical system to the Servomotor shaft (i.e., make sure there is no load), and perform the adjustments while monitoring the waveform of the analog monitor output's torque command monitor (current monitor).
- The Servomotor current detection offset setting range is -512 to 511.

Note If adjusting the Servomotor current detection offset, first try performing automatic adjustment (Fn00E). Only attempt manual adjustment if the torque ripple is still large after performing automatic adjustment.

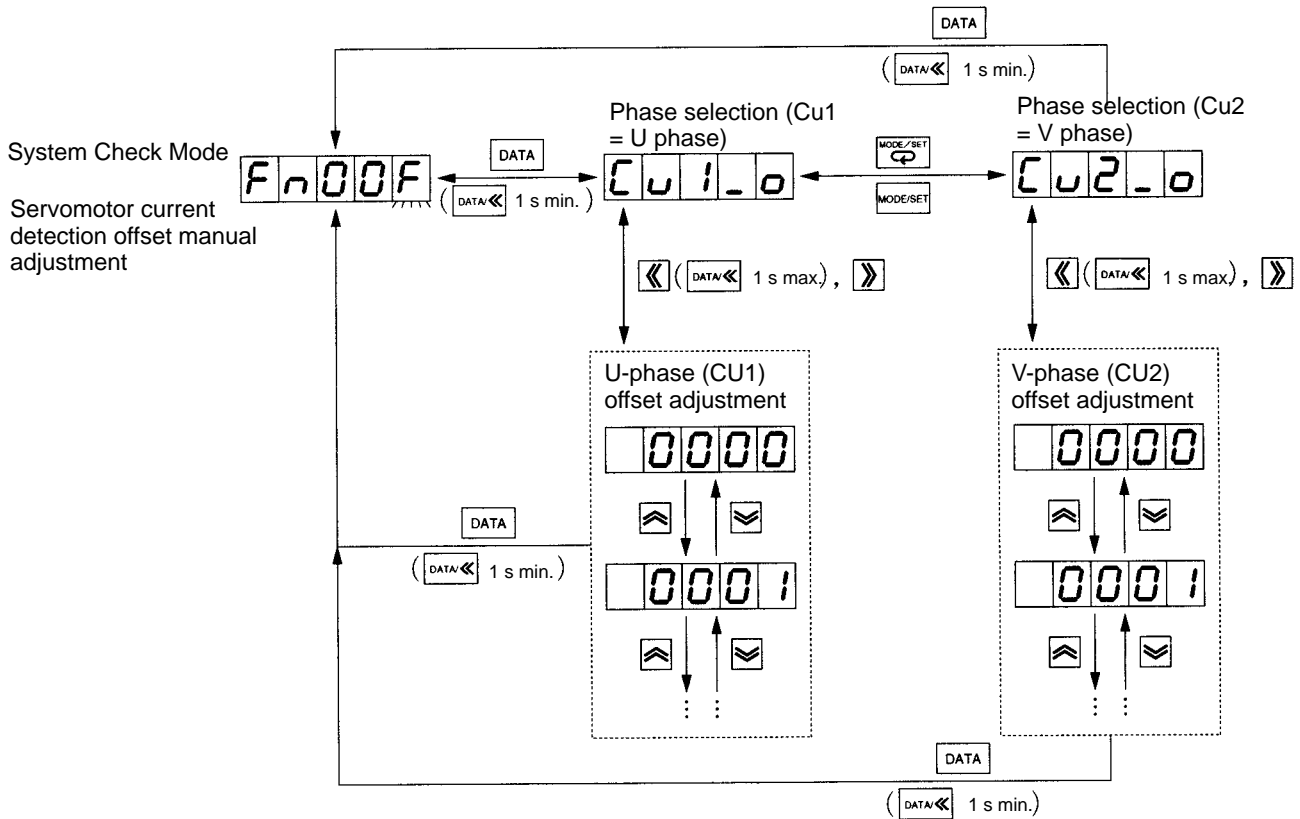

Flowchart for Servomotor Current Detection Offset Manual Adjustment

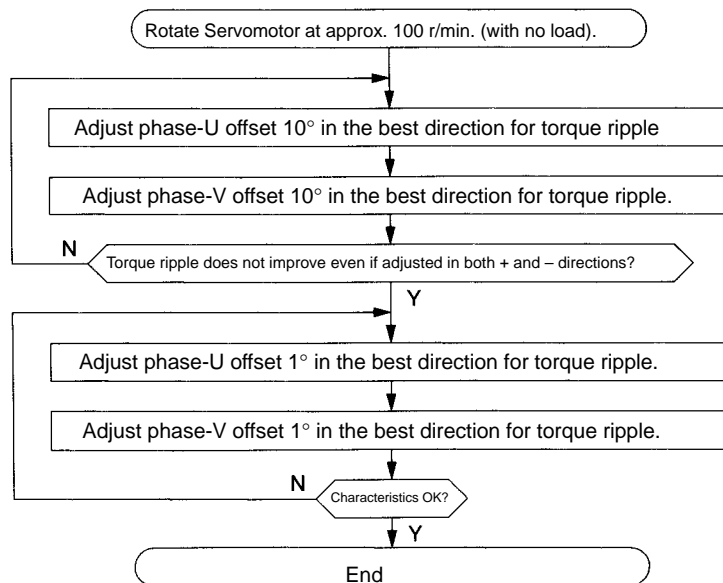

Note 1. Adjust the offset while monitoring the torque command monitor (current monitor)'s waveform.

Note 2. Perform rough adjustments in units of 10°, and fine adjustments in units of 1°. (You can also perform intermediate adjustments in units of 5°.)

Note 3. Do not greatly adjust either U phase or V phase alone.

Operation Procedure

PR02W operation	Front panel key operation	Display	Explanation
			Press the MODE/SET Key to change to System Check Mode.
			Press the Up or Down Key to set function code Fn00F. (See note.)
			Press the DATA Key (front panel: DATA Key for 1 s min.) to display “Cu1_o” (U phase)
			Press the Left Key (front panel: DATA Key for less than 1 s) or Right Key to display the U-phase offset amount.
			Press the Up or Down Key to change the offset amount. Change the offset in units of 10° in the direction in which the torque ripple is reduced.
			Press the Left Key (front panel: DATA Key for less than 1 s) or Right Key to return to the “Cu1_o” display.
			Press the MODE/SET Key to display “Cu2_o.” (V phase).
			Press the Left Key (front panel: DATA Key for less than 1 s) or Right Key to display the V-phase offset amount.
			Press the Up or Down Key to change the offset amount. Change the offset in units of 10° in the direction in which the torque ripple is reduced.
			Press the Left Key (front panel: DATA Key for less than 1 s) or Right Key to return to the “Cu2_o” display.
			Press the MODE/SET Key to display “Cu1_o.”
Repeat the above operation (phase-U adjustment to phase-V adjustment) until the torque ripple improves no further even by changing the offset in both the + and – directions. Next, finely adjust the phase U and phase V in the same way.			
			When you have completed the Servomotor current detection offset adjustment, press the DATA Key (front panel: DATA Key for 1 s min.) to return to the System Check Mode function code display.

Note The digits you can manipulate will flash.

4-11-8 Password Setting

■ Password Setting (Fn010)

- This function prevents the user parameter settings and System Check Mode settings and adjustments being overwritten unintentionally.
- When a write-prohibited password is set, from the next power-up onwards it becomes impossible to make parameter settings or to make settings or adjustments in System Check Mode. It still remains possible, however, to refer to the user parameters and perform some functions in System Check Mode. The functions that can be performed in System Check Mode while write prohibited is enabled are as follows:

Display alarm log (Fn000), password setting (Fn010), Servomotor parameters check (Fn011), and version check (Fn012).

If you try to perform any functions other than these, “nO OP” will flash for approximately 1 s, and then the display will return to the function code.

- If you set the write-enabled password, the write-prohibited status will be cancelled (i.e., you can write to the user parameters, etc., when the power is next turned ON again).

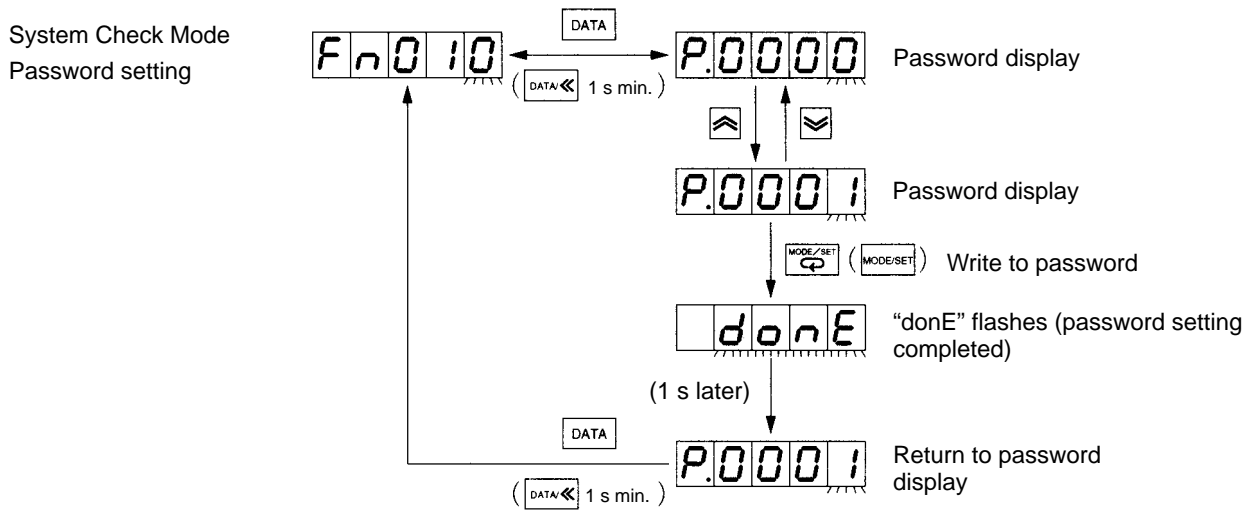

Operation Procedure

PR02W operation	Front panel key operation	Display	Explanation
			Press the MODE/SET Key to change to System Check Mode.
			Press the Up or Down Key to set function code Fn010. (See note 1.)
			Press the DATA Key (front panel: DATA Key for 1 s min.) to display the password "P.□□□□."
			Press the Up or Down Key to select the password. 0000: Write enabled, 0001: Write prohibited.
			Press the MODE/SET Key to set the password. When setting is complete, "donE" will flash for approximately 1 s.
(Approx. 1 s later)			After displaying "donE," the display will return to "P.□□□□."
			Press the DATA Key (front panel: DATA Key for 1 s min.) to return to the System Check Mode function code display.

Note 1. The digits you can manipulate will flash.

Note 2. If this is set to any value other than 0000 or 0001, "Error" will flash for approximately 1 s, and then the display will return to the original password.

4-11-9 Checking Servomotor Parameters

■ Checking Servomotor Parameters (Fn011)

- You can check the type of Servomotor, encoder, etc., that is connected.

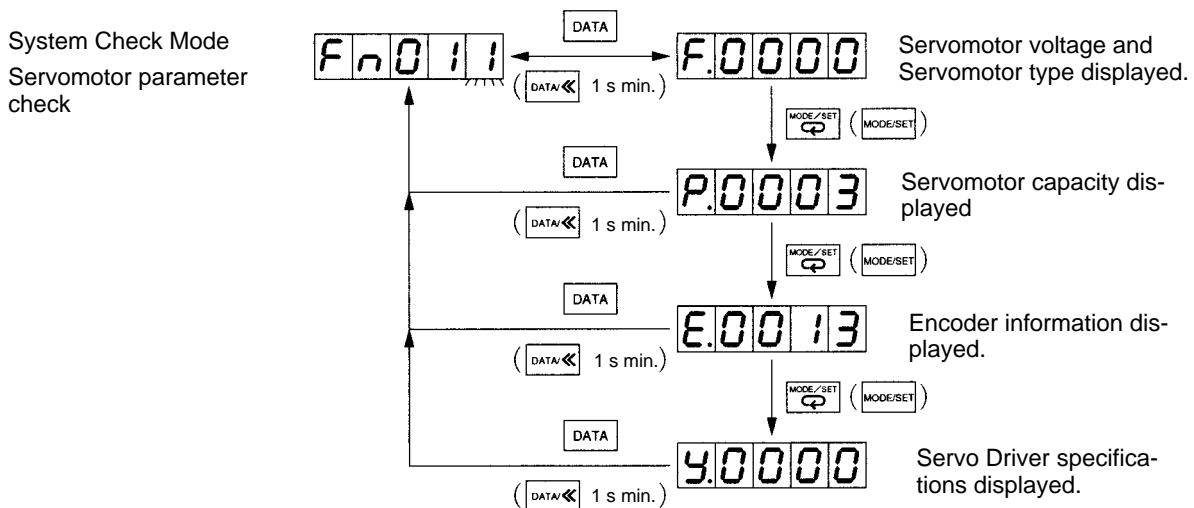

Servomotor Voltage and Servomotor Type



Servomotor type
Servomotor voltage

Servomotor voltage

Data	Voltage
00	100 V AC
01	200 V AC

Servomotor type

Data	Servomotor Type
00	3,000 r/min. (30 to 750 W)
01	3,000 r/min. Flat-style
02	3,000 r/min. (1 to 5 kW)
03	1,500 r/min.
04	1,000 r/min.

Servomotor Capacity



Servomotor capacity

Note Servomotor capacity is the displayed value x 10 (W). The example on the left shows a Servomotor capacity of 30 W.

Encoder Information



Encoder resolution
Encoder type

Encoder type

Data	Type
00	Incremental encoder
01	Absolute encoder

Encoder resolution

Data	Resolution
13	13-bit (2,048 pulses/rotation)
16	16-bit (16,384 pulses/rotation)
17	17-bit (32,768 pulses/rotation)

Driver Specification

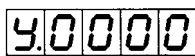

Driver specification

Note "0000" is displayed for standard specifications. Other numbers are displayed for special specifications.

Operation Procedures

PR02W operation	Front panel key operation	Display	Explanation
			Press the MODE/SET Key to change to System Check Mode.
			Press the Up or Down Key to set function code Fn011. (See note.)
			Press the DATA Key (front panel: DATA Key for 1 s min.). Servomotor voltage and Servomotor type are displayed as "F.□□□□."
			Press the MODE/SET Key. Servomotor capacity is displayed as "P.□□□□."
			Press the MODE/SET Key. Encoder information is displayed as "E.□□□□."
			Press the MODE/SET Key. Servo Driver specification is displayed as "y.□□□□."
			Press the DATA Key (front panel: DATA Key for 1 s min.) to return to the System Check Mode function code display.

Note The digits you can manipulate will flash.

4-11-10 Checking the Version

■ Version Check (Fn012)

- You can use this function to check the Servo Driver and encoder software versions.

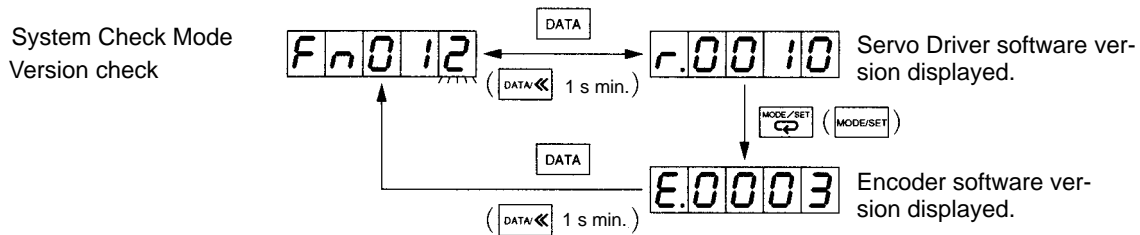

Operation Procedure

PR02W operation	Front panel key operation	Display	Explanation
		Fn000	Press the MODE/SET Key to change to System Check Mode.
		Fn012	Press the Up or Down Key to set function code Fn012. (See note.)
		r.0010	Press the DATA Key (front panel: DATA Key for 1 s min.). Driver software version is displayed as "r.□□□□."
		E.0003	Press the MODE/SET Key. Encoder software version is displayed as "E.□□□□."
		Fn012	Press the DATA Key (front panel: DATA Key for 1 s min.) to return to the System Check Mode function code display.

Note The digits you can manipulate will flash.

4-11-11 Changing Absolute Encoder Rotation Setting (ABS)

■ Changing Absolute Encoder Multi-turn Setting (Fn013)

- When you change the setting for user parameter Pn205 (absolute encoder multi-turn limit setting), and turn OFF the power supply to the Servo Driver and then back ON again, an A.CC (multi-turn limit nonconformity) alarm occurs. When this alarm occurs, you can change the setting in the encoder to the same as the Servo Driver setting by means of Fn013 (absolute encoder multi-turn setting change). After changing the setting, turn OFF the power, then turn it ON again, to clear the A.CC alarm.

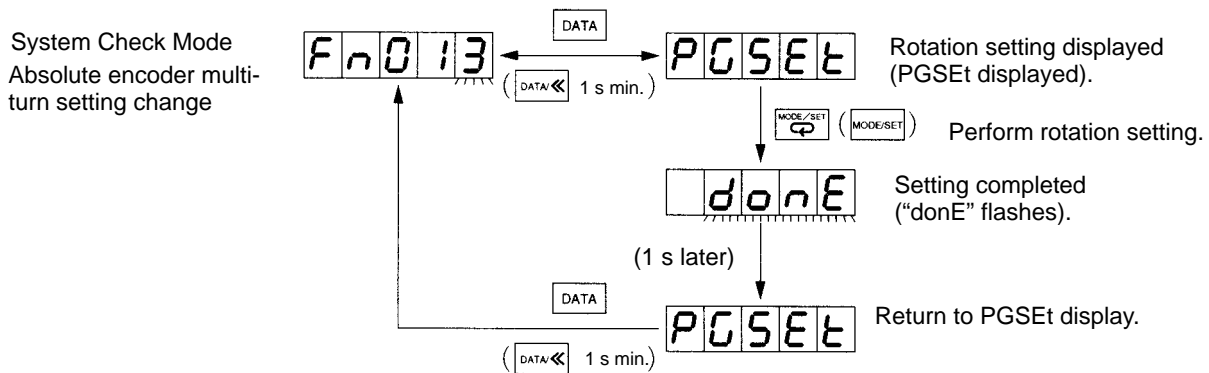

Operation Procedure

PR02W operation	Front panel key operation	Display	Explanation
		=.ACC	Status Display Mode. (See note 1.)
	MODE/SET	Fn000	Press the MODE/SET Key to change to System Check Mode.
	↑ ↓	Fn013	Press the Up or Down Key to set function code Fn013. (See note 2.)
	DATA (1 s min.)	PGSEt	Press the DATA Key (front panel: DATA Key for 1 s min.) to display "PGSEt."
	MODE/SET	donE	Press the MODE/SET Key. Multi-turn setting change will be performed. When the setting is completed, "donE" will flash for approximately 1 s.
(Approx. 1 s later)		PGSEt	After "donE" has been displayed, the display will return to "PGSEt."
	DATA (1 s min.)	Fn013	Press the DATA Key (front panel: DATA Key for 1 s min.) to return to the System Check Mode function code display. (See note 3.)

Note 1. Perform the above operation when A.CC is displayed.

Note 2. The digits you can manipulate will flash.

Note 3. The A.CC alarm will be cleared the next time the power supply is turned OFF, then ON again.

4-11-12 Clearing Option Unit Detection Results

■ Option Unit Detection Results Clear (Fn014)

- If an Option Unit is removed and then the power supply is turned ON, an A.E7 alarm (option detection error) will occur. This is because the Servo Driver has determined that an error exists because the Option Unit cannot be detected.
- If an A.E7 alarm occurs, use one of the following methods to clear the alarm.

● Using an Option Unit

Turn OFF the power supplies, mount the Option Unit properly, and turn ON the power supplies.

● Not Using an Option Unit

Initialize the user parameters (by executing Fn005), clear the Option Unit detection results (by executing Fn014), and reset the power supplies.

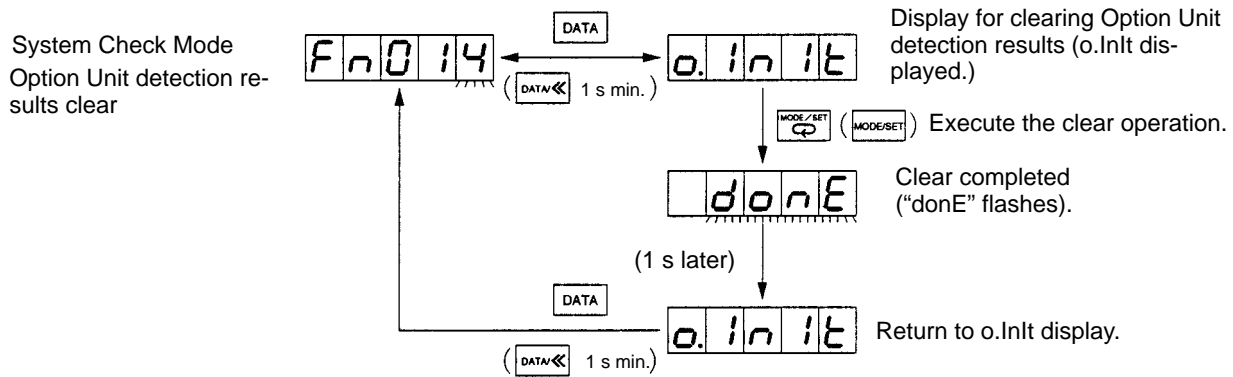

Operation Procedure

PR02W operation	Front panel key operation	Display	Explanation
		≡ . A.E7	Status Display Mode. (See note 1.)
		Fn000	Press the MODE/SET Key to change to System Check Mode.
		Fn014	Press the Up or Down Key to set function code Fn014. (See note 2.)
		o.InIt	Press the DATA Key (front panel: DATA Key for 1 s min.) to display "o.InIt."
		donE	Press the MODE/SET Key. The Option Unit detection results will be cleared. When the clear operation is completed, "donE" will flash for approximately 1 s.
(Approx. 1 s later)		o.InIt	After "donE" has been displayed, the display will return to "o.InIt."
		Fn014	Press the DATA Key (front panel: DATA Key for 1 s min.) to return to the System Check Mode function code display.

Note 1. Perform the above operation when A.E7 is displayed.

Note 2. The digits you can manipulate will flash.

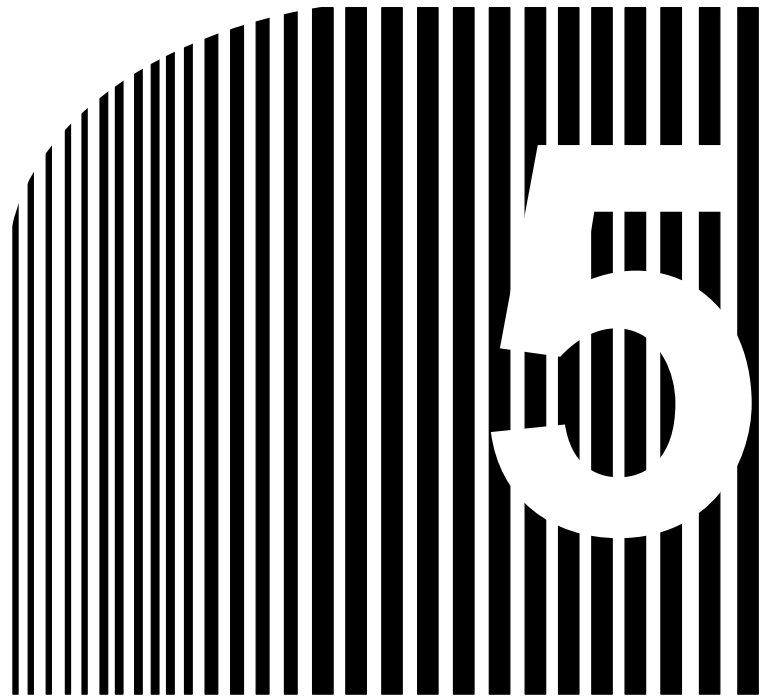

Chapter 5

• Troubleshooting •

- 5-1 Measures when Trouble Occurs
- 5-2 Alarms
- 5-3 Troubleshooting
- 5-4 Overload Characteristics
(Electron Thermal Characteristics)
- 5-5 Periodic Maintenance
- 5-6 Replacing the Absolute Encoder Battery (ABS)

5-1 Measures when Trouble Occurs

5-1-1 Preventive Checks Before Trouble Occurs

This section explains the preventive checks and analysis tools required to determine the cause of trouble when it occurs.

■ Check the Power Supply Voltage

- Check the voltage to the power supply input terminals.

Main-circuit Power Supply Input Terminals (L1, L2, (L3))

R88D-WT□H

(30 to 400 W): Single-phase 200/230 V AC (170 to 253 V) 50/60 Hz

(500 W to 15 kW): 3-phase 200/230 V AC (170 to 253 V) 50/60 Hz

R88D-WT□HL (30 to 200 W): Single-phase 100/115 V AC (85 to 127 V) 50/60 Hz

Control-circuit Power Supply Input Terminals (L1C, L2C)

R88D-WT□H: Single-phase 200/230 V AC (170 to 253 V) 50/60 Hz

R88D-WT□HL: Single-phase 100/115 V AC (85 to 127 V) 50/60 Hz

If the voltage falls outside of this range, there is a risk of misoperation, so make sure that the power supply is correct.

- Make sure that the voltage of the sequence input power supply (+24 VIN Terminal (CN1-47 pin)) is within the range 23 to 25 VDC. If the voltage falls outside of this range, there is a risk of misoperation, so make sure that the power supply is correct.

■ Selecting Analysis Tools

● Check Whether an Alarm Has Occurred

- If an alarm has occurred, check the alarm code (A.□□), and perform analysis depending on the alarm code.

Note If an Option Unit is installed, an Option Unit error code may be output. For details, also refer to the operation manual for the Option Unit.

- If an alarm has not occurred, perform analysis depending on the error.

Note Refer to 5-3 *Troubleshooting* in either case.

● Types of Analysis Tools

- The types of analysis tools are as follows:

Servo Driver Indicators and Parameter Unit

- Perform analysis using the display (7-segment LEDs) and the operation keys on the front panel of the Servo Driver. You can also perform the same operation using the Parameter Unit (R88A-PR02W). This manual explains analysis using these methods.

Computer Monitor Software

- Install and use the OMNUC W-series Servo Driver Computer Monitor Software (for Windows 95). The following three items are required: An IBM PC/AT or compatible with Windows 95, the Computer Monitor Software, and Connecting Cable (R88A-CCW002P□).
- Refer to the Computer Monitor Software for operation details.

5-1-2 Precautions

When checking and verifying I/O after trouble has occurred, the Servo Driver may suddenly start to operate or suddenly stop, so take precautions. Also, do not attempt operations not specified in this manual.

■ Precautions

- Disconnect any cables before checking if they have burned out. Even if you have checked the conduction of the wiring, there is a risk of conduction due to the return circuit.
- If the encoder signal is lost, the Servomotor may run away, or an error may be generated. Make sure the Servomotor is disconnected from the mechanical system before checking the encoder signal.
- When measuring the encoder output, measure using the ground (CN1-1 pin) as standard. If measuring using an oscilloscope, measure using the differential between CH1 and CH2 to reduce interference from noise.
- When performing tests, first check that there are no personnel inside the machine facilities, and that the facilities will not be damaged even if the Servomotor runs away. Also, check that even if the Servomotor runs away, you can immediately stop the machine using an emergency stop before performing the tests.

5-1-3 Replacing the Servomotor and Servo Driver

Perform the following procedure to replace the Servomotor or Servo Driver.

■ Replacing the Servomotor

1. Replace the Servomotor.
2. Perform origin teaching (if using position control).
 - When replacing the Servomotor, the Servomotor's specific origin position (Z-phase) may slip, so be sure to perform origin teaching.
 - Refer to the manual for the position controller you use for how to perform origin teaching.
3. Set up the absolute encoder (ABS).
 - If using a Servomotor with an absolute encoder, when replacing the Servomotor, the absolute data in the absolute encoder will be cleared, so you need to set up the data again. Also, the rotation limit data will be different from before you replaced the Servomotor, so initialize the Motion Control Unit settings.

Note Refer to *4-2-2 Absolute Encoder Setup and Battery Changes* for details.

- Also, if you have changed the setting in Pn205 (absolute encoder multi-turn limit setting), an A.CC (rotation speed mismatch) alarm will occur, so change the rotation limit setting (Fn013) using system check mode.

■ Replacing the Servo Driver

1. Make a note of the parameters.
 - If using Computer Monitor Software, start the program, and transfer and save all the parameters in the Servo Driver to the personal computer.
 - If not using Computer Monitor Software, write all of the parameter settings using Parameter Unit or Servo Driver operation keys. (Refer to *6-4 Parameter Setting Value Table*.)
2. Replace the Servo Driver.
3. Set the parameters.
 - If using Computer Monitor Software, transfer all the parameters stored in the personal computer to the Servo Driver.
 - If not using Computer Monitor Software, set all the parameters using a Parameter Unit or Servo Driver operation keys.
4. Set up the absolute encoder (ABS).
 - If using a Servomotor with an absolute encoder, when replacing the Servomotor, the absolute data in the absolute encoder will be cleared, so you need to reset the data. Also, the rotation limit data will be different from before you replaced the Servomotor, so initialize the Motion Control Unit settings.

Note Refer to *4-2-2 Absolute Encoder Setup and Battery Changes* for details.

5-2 Alarms

If the Servo Driver detects an error, \overline{ALM} (alarm output) and ALO1 to ALO3 (alarm codes) are output, the power drive circuit in the Servo Driver turns OFF, and the alarm is displayed. If the Servo Driver detects a warning (e.g., overload warning or regenerative overload warning), WARN (warning output) and ALO1 to ALO3 (warning codes) are output, and the warning is displayed. (Operation continues.)

Note 1. Warning outputs and warning codes are output only if the parameters have been set (Pn50F.3, Pn001.1).

Note 2. If an Option Unit is installed, an Option Unit error code may be output. For details, also refer to the operation manual for the Option Unit.

When a Yaskawa JUSP-NS115 MECHATROLINK-II Option Unit (OMRON model number: FNY-NS115) is mounted to the Servo Driver, there are other Option Board alarms and warnings in addition to those listed below. For details, refer to *6-5 Alarms and Warnings when a JUSP-NS115 MECHATROLINK-II Option Unit is Mounted*.

Note 3. Refer to *5-3-1 Error Diagnosis Using Alarm Display* for appropriate alarm countermeasures.

Note 4. Cancel the alarm using one of the following methods. (Remove the cause of the alarm first.)

- Input a RESET (alarm reset) signal.
- Turn OFF the power supply, then turn it ON again.
- Press the **RESET** Key on the Parameter Unit, or press the **Up** and **Down** Keys together on the front panel. The following alarms can only be cancelled by turning OFF the power supply, then turning it ON again: A.02, A.04, A.10, A.81, A.82, A.83, A.84, A.C9, A.Cb, A.CC, and A.E7.

Note 5. If you cancel an alarm while RUN is turned ON, the Servo Driver will start as soon as the alarm is cleared, which is dangerous. Be sure to turn OFF the RUN command before cancelling the alarm. If the RUN command is ON, or the servo is always ON (setting Pn50A.1 = 7), first check safety sufficiently before cancelling the alarm.

■ Alarm Table

Display	Alarm code			Error detection function	Cause of error
	ALO1	ALO2	ALO3		
A.02	OFF	OFF	OFF	Parameter corruption	The checksum for the parameters read from the EEPROM does not match.
A.03	OFF	OFF	OFF	Main circuit detection error	There is an error in the detection data for the power supply circuit.
A.04	OFF	OFF	OFF	Parameter setting error	Incorrect parameter setting.
A.05	OFF	OFF	OFF	Motor mismatch	The Servomotor does not match the Servo Driver.
A.10	ON	OFF	OFF	Overcurrent	Overcurrent detected, or improper radiation shield temperature rise detected. (1.5 to 3 kW only).
A.30	ON	ON	OFF	Regeneration error	Regeneration circuit damaged due to large amount of regenerative energy.
A.32	ON	ON	OFF	Regeneration overload	Regenerative energy exceeded the regeneration resistance.

Display	Alarm code			Error detection function	Cause of error
	ALO1	ALO2	ALO3		
<i>A.33</i>	ON	ON	OFF	Main-circuit power supply setting error (See note 3.)	The setting of Pn001.2 (AC/DC input selection) and the AC/DC wiring method of the main circuit power supply are not the same.
<i>A.40</i>	OFF	OFF	ON	Overvoltage	Main circuit DC voltage above the allowable range.
<i>A.41</i>	OFF	OFF	ON	Low voltage	Main circuit DC voltage below the allowable range.
<i>A.51</i>	ON	OFF	ON	Overspeed	Servomotor rotation speed exceeded the maximum speed.
<i>A.71</i>	ON	ON	ON	Overload	Output torque exceeded 245% of rated torque.
<i>A.72</i>	ON	ON	ON	Overload	Output torque continued at 120% to 245% of rated torque.
<i>A.73</i>	ON	ON	ON	Dynamic brake overload	Regenerative energy exceeded the dynamic brake resistance during dynamic brake operation.
<i>A.74</i>	ON	ON	ON	Inrush resistance overload	Inrush current exceeded the inrush resistance during power supply inrush.
<i>A.7A</i>	ON	ON	ON	Overheat	Abnormal temperature rise detected in radiation shield.
<i>A.81</i>	OFF	OFF	OFF	Backup error (ABS)	Encoder backup power supply dropped.
<i>A.82</i>	OFF	OFF	OFF	Checksum error (ABS)	Checksum error for encoder memory data.
<i>A.83</i>	OFF	OFF	OFF	Battery error (ABS)	Encoder battery voltage dropped (to 2.7 V or lower).
<i>A.84</i>	OFF	OFF	OFF	Absolute error	Encoder internal data error
<i>A.85</i>	OFF	OFF	OFF	Overspeed error (ABS)	Servomotor rotation speed exceeded 200 r/min when encoder power was turned ON.
<i>A.86</i>	OFF	OFF	OFF	Encoder overheating (ABS)	Abnormal encoder temperature rise detected.
<i>A.b1</i>	OFF	OFF	OFF	Speed command input reading error	The A/D end signal was not output from the A/D converter within a fixed time.
<i>A.b2</i>	OFF	OFF	OFF	Torque command input reading error	The A/D end signal was not output from the A/D converter within a fixed time.
<i>A.bF</i>	OFF	OFF	OFF	System error	A control circuit system error was detected.
<i>A.C1</i>	ON	OFF	ON	Runaway detected.	The Servomotor rotated in the opposite direction from the command.
<i>A.C8</i>	ON	OFF	ON	Multi-turn data error (ABS)	Absolute encoder setup was incorrect.
<i>A.C9</i>	ON	OFF	ON	Encoder communications error	No communication between encoder and Servo Driver.
<i>A.CA</i>	ON	OFF	ON	Encoder parameter error	Encoder parameters are corrupted.
<i>A.Cb</i>	ON	OFF	ON	Encoder data error	Data from the encoder is corrupted.
<i>A.Cc</i>	ON	OFF	ON	Multi-turn limit discrepancy	The multi-turn limits for the encoder and the Servo Driver do not conform.
<i>A.d0</i>	ON	ON	OFF	Deviation counter overflow	Deviation counter's residual pulses exceeded the deviation counter overflow level set in Pn505.

Display	Alarm code			Error detection function	Cause of error
	ALO1	ALO2	ALO3		
<i>R.d 1</i>	ON	ON	OFF	Motor-load deviation over (See note 3.)	The error for a fully-closed or semi-closed encoder is greater than or equal to the number of command units set in Pn51A.
<i>R.E 7</i>	OFF	ON	ON	Option detection error (See note 3.)	An Option Unit has been removed.
<i>R.F 1</i>	OFF	ON	OFF	Missing phase detected.	Main-circuit power supply missing phase or disconnection detected.
<i>R.F 5</i>	OFF	ON	OFF	Motor current error (See note 4.)	The current that flows to the Servomotor is abnormally small for the torque command from the Servo Driver.
<i>R.F 6</i>	OFF	ON	OFF	Motor conduction error (See note 4.)	When the Servomotor is ON, the baseblock condition continues, regardless of the Servo Driver settings or external input.
<i>CPF00</i>	---	---	---	Parameter Unit transmission error 1	Data could not be transmitted after the power supply was turned ON.
<i>CPF01</i>	---	---	---	Parameter Unit transmission error 2	Transmission timeout error

Note 1. Alarm codes designated “---” are undefined.

Note 2. When an alarm occurs, \overline{ALM} (alarm output) is turned OFF.

Note 3. These alarms are supported for Servo Drivers with a software version of “r.0014” or later.

Note 4. These alarms are supported for Servo Drivers with a software version of “r.0037” or later.

■ **Warning Table**

Display	Alarm code			Warning detection function	Meaning
	ALO1	ALO2	ALO3		
<i>R.90</i>	OFF	OFF	OFF	Deviation counter overflow (See note 6.)	Deviation counter residual pulses exceeded the deviation counter overflow level set in Pn505 multiplied by the ratio (%) set in Pn51E.
<i>R.91</i>	ON	OFF	OFF	Overload	When a warning occurs before the overload alarm (A.71, A.72) is reached, the alarm may be generated if the Servomotor continues to operate.
<i>R.92</i>	OFF	ON	OFF	Regeneration overload	When a warning occurs before the regeneration overload alarm (A.32) is reached, the alarm may be generated if the Servomotor continues to operate.
<i>R.93</i>	ON	ON	OFF	Battery warning (ABS) (See note 5.)	A battery alarm (A.83) will occur in the near future, possibly the next time the power supply is turned ON. (Replace with battery with the control circuit power supply turned ON.)

Note 1. Alarm codes designated “---” are undefined.

Note 2. When Pn001.3 (warning code output selection) is set to 1, warning codes will be output (default setting is 1).

Note 3. To output warnings, allocate the output terminal using Pn50F.3 (WARN signal output terminal allocation).

Note 4. This warning is supported for Servo Drivers with a software version of “r.0014” or later.

Note 5. This warning is supported for Servo Drivers with a software version of “r.0037” or later.

5-3 Troubleshooting

If an error occurs in the machinery, check the type of error using the alarm indicators and operation status, verify the cause, and take appropriate countermeasures.

5-3-1 Error Diagnosis Using Alarm Display

- Note 1.** If an Option Unit is installed, an Option Unit error code may be output. For details, also refer to the operation manual for the Option Unit.
- Note 2.** Alarms marked with one asterisk are supported for Servo Drivers with a software version of “r.0014” or later.
- Note 3.** Warnings marked with two asterisks are supported for Servo Drivers with a software version of “r.0037” or later.

Display	Error	Status when error occurs	Cause of error	Countermeasures
A.02	Parameters corrupted	Occurs when control circuit power supply is turned ON.	Power supply was turned OFF while parameters were being written.	Initialize (Fn005) the user parameters, and then re-set the parameters.
			Internal memory error	Replace the Servo Driver.
A.03	Main circuit detection error	Occurs when main circuit power supply is turned ON.	Main circuit detection data error	Replace the Servo Driver.
A.04	Parameter setting error	Occurs when control circuit power supply is turned ON.	A value outside of the setting range was previously set in the parameters.	Reset the parameters within the setting range.
			Control panel error	Replace the Servo Driver.
A.05	Servomotor mismatch	Occurs when control circuit power supply is turned ON.	Servomotor and Servo Driver combination is incorrect.	Correct the combination.
			Encoder internal data error	Replace the Servomotor.

Display	Error	Status when error occurs	Cause of error	Countermeasures
A.10	Overcurrent	Occurs when power supply is turned ON.	Control panel error Main circuit transistor module error	Replace the Servo Driver.
		Occurs when servo is turned ON.	Current feedback circuit error Main circuit transistor module error	Replace the Servo Driver.
			Servomotor power line is short-circuited or grounded between phases.	Repair the short-circuited or grounded wire. Measure the insulation resistance at the Servomotor and, if there is a short-circuit, replace the Servomotor.
			Miswiring between U-phase, V-phase, W-phase, and ground.	Correct the wiring.
			Servomotor winding is burned out.	Measure the winding resistance, and if the winding is burned out, replace the Servomotor.
			Ambient Servo Driver temperature exceeds 55°C.	Lower the Servo Driver's ambient temperature to 55°C or less.
			Radiation shield air convection is poor.	Mount according to mounting conditions.
			The fan has stopped.	Replace the Servo Driver.
			Operating above rated output.	Lighten the load.
A.30	Regeneration error	Occurs during operation.	Error in the regenerative circuit parts.	Replace the Servo Driver.
			External Regeneration Resistor is burned out.	Replace the External Regeneration Resistor.
			Apart from a short-circuit between B2 and B3, the external circuit resistor is not connected.	Correctly connect the external circuit resistor (between B1 and B2).
A.32	Regeneration overload	Occurs during operation.	Regenerative energy exceeds tolerance.	Calculate the regenerative energy, and connect an external Regeneration Resistor with the required regeneration absorption capacity.
			Setting error in Pn600 (regeneration resistor capacity)	Set Pn600 correctly.

Display	Error	Status when error occurs	Cause of error	Countermeasures
A.33	Main-circuit power supply setting error*	Occurs when the main circuit power supply is turned ON.	The setting of Pn001.2 (AC/DC input selection) and the AC/DC wiring method of the main circuit power supply are not the same.	Correct the setting of Pn001.2. Correct the wiring.
			Servo Driver is faulty.	Replace the Servo Driver.
A.40	Overvoltage	Occurs when power supply is turned ON.	Main circuit power supply voltage is outside tolerance range.	Change the main circuit power supply voltage to within tolerance range.
		Occurs when Servomotor is decelerating.	Load inertia is too great.	Deceleration time is too long. Calculate the regenerative energy, and connect an external Regeneration Resistor with the required regeneration absorption capacity.
		Occurs during descent (vertical axis)	Gravitational torque is too large.	Reduce main circuit power supply voltage exceeds tolerance range. Add a counterbalance to the machinery to lower gravitational torque. Slow the descent speed. Calculate the regenerative energy, and connect and external Regeneration Resistor with the required regeneration absorption capacity.
A.41	Low voltage	Occurs when the control circuit power supply only is turned ON.	Control panel error	Replace the Servo Driver.
		Occurs when the main circuit power supply is turned ON.	Main circuit power supply voltage is outside tolerance range.	Change the main circuit power supply voltage to within tolerance range.
			Main circuit power supply is damaged.	Replace the Servo Driver.

Display	Error	Status when error occurs	Cause of error	Countermeasures
R51	Overspeed	Occurs when the servo is ON.	Encoder signal between controllers is wired incorrectly.	Rewire correctly.
			Servomotor power line is wired incorrectly.	Rewire correctly.
		Occurs along with high-speed rotation when a command is input.	Position and speed command inputs are too large.	Input command values correctly.
			Pn300 (speed command scale), and Pn202 and Pn203 (electronic gear) settings are too large.	Set the parameters correctly.
			Speed limit is not performed during torque control.	Set Pn407 (speed limit)
			Rotation limit has been exceeded due to overshooting.	Adjust the gain. Lower the maximum specified speed.
R71	Overload	Occurs during operation.	Running at over 245% of rated torque (effective torque).	Repair the Servomotor shaft if it is locked. If the Servomotor power line is wired incorrectly, rewire it correctly. Lighten the load. Lengthen the acceleration and deceleration times. Adjust the gain.
			Power supply voltage has fallen.	Check the power supply voltage, and lower to within tolerance range.
R72	Overload	Occurs during operation.	Running at 120% to 245% of rated torque (effective torque).	Lighten the load. Lengthen the acceleration and deceleration times. Adjust the gain.
			Power supply voltage has fallen.	Check the power supply voltage, and lower to within tolerance range.
R73	Dynamic brake overload	Occurs when the servo is turned OFF after operating.	Energy required for stopping exceeds the dynamic brake resistor tolerance.	Lower the rotation speed. Reduce the load inertia. Reduce the frequency of dynamic brake use.
		Occurs when the power supply is turned ON.	Control panel error	Replace the Servo Driver.

Display	Error	Status when error occurs	Cause of error	Countermeasures
A.74	Inrush resistance overload	Occurs when the main circuit power supply is turned ON.	Inrush current when the main circuit power supply is turned ON exceeds inrush resistor tolerance.	Reduce the frequency by which the main circuit power supply is turned ON and OFF.
		Occurs when the control circuit power supply only is turned ON.	Control panel error	Replace the Servo Driver.
A.7A	Overheat	Occurs when the control circuit power supply only is turned ON.	Control panel error	Replace the Servo Driver.
		Occurs during operation.	Control panel error	Replace the Servo Driver.
			Ambient Servo Driver temperature exceeds 55°C.	Lower the Servo Driver's ambient temperature to 55°C or less.
			Radiation shield sink air convection is poor.	Mount according to mounting conditions.
			The fan has stopped.	Replace the Servo Driver.
Operating above rated output.	Lighten the load.			
A.81	Backup error (ABS)	Occurs when control circuit power supply is turned ON.	Absolute encoder backup voltage has fallen. Occurs the first time the encoder is used.	Set up the absolute encoder correctly.
A.82	Checksum error (ABS)	Occurs when control circuit power supply is turned ON.	Absolute encoder memory check error	Set up the absolute encoder correctly.
A.83	Battery error (ABS)	Occurs when control circuit power supply is turned ON.	Absolute encoder battery voltage has fallen (to 2.7 V or less)	Replace the battery while the control circuit power supply is ON.
A.84	Absolute error	Occurs when control circuit power supply is turned ON or during operation.	Absolute encoder sensor check error (internal encoder error)	Turn OFF the power supply, then ON again. Take noise countermeasures. Replace the Servomotor (if the cause is encoder error).
			Encoder is defective.	Replace the Servomotor
			Servo Driver is defective.	Replace the Servo Driver.
A.85	Overspeed error (ABS)	Occurs when control circuit power supply is turned ON.	Servomotor is rotating at 200 r/min. or more when the control circuit power supply is turned ON.	Turn ON the control circuit power supply while the Servomotor is OFF.

Display	Error	Status when error occurs	Cause of error	Countermeasures
<i>A.B6</i>	Encoder overheating (ABS)	Occurs when the control circuit power supply is turned ON.	Encoder is defective.	Replace the Servomotor
		Occurs during operation.	Ambient Servomotor temperature exceeds 40°C.	Lower the ambient temperature to 40°C or less.
			Servomotor spring mounting clip is too small.	Use a spring mounting clip the same dimensions or greater than those of the radiation shield indicated in the Servomotor efficiency specifications.
			Operating above rated output	Lighten the load
<i>A.b1</i>	Command input reading error	Occurs during operation.	Command input reader misoperation	Reset the alarm, then restart the operation.
			Command input reader is broken.	Replace the Servo Driver.
<i>A.b2</i>	Command input reading error	Occurs during operation.	Command input reader misoperation	Reset the alarm, then restart the operation.
			Command input reader is broken.	Replace the Servo Driver.
<i>A.bF</i>	System error	Occurs during operation.	Control panel error	Replace the Servo Driver.
<i>A.C1</i>	Runaway detected	Occurs when there is a slight movement upon startup.	Encoder is wired incorrectly. Servomotor power line is wired incorrectly.	Correct the wiring.
<i>A.CB</i>	Rotation data error (ABS)	Occurs when the control circuit power supply is turned ON.	Encoder is defective	Replace the Servomotor
			Servo Driver is defective.	Replace the Servo Driver.
<i>A.C9</i>	Encoder communications error	Occurs when the control circuit power supply is turned ON, or occurs during operation.	Encoder signal is wired incorrectly	Correct the wiring.
			Encoder is defective	Replace the Servomotor
			Servo Driver is defective.	Replace the Servo Driver.
<i>A.CA</i>	Encoder parameter error	Occurs when the control circuit power supply is turned ON.	Encoder is defective	Replace the Servomotor
			Servo Driver is defective.	Replace the Servo Driver.
<i>A.Cb</i>	Encoder data error	Occurs when the control circuit power supply is turned ON.	Encoder signal is wired incorrectly	Correct the wiring.
			Encoder is defective	Replace the Servomotor
			Servo Driver is defective.	Replace the Servo Driver.

Display	Error	Status when error occurs	Cause of error	Countermeasures
<i>A.C.C</i>	Multi-turn limit mismatch (ABS)	Occurs when the control circuit power supply is turned ON.	Pn205 (absolute encoder rotation limit setting) changed.	Perform absolute encoder rotation limit setting change (Fn013).
			Pn205 (absolute encoder rotation limit setting) changed by mistake.	Set Pn205 correctly
<i>A.d0</i>	Deviation counter overflow	Servomotor will not rotate even when command pulses are input.	Servomotor power or encoder line is wired incorrectly.	Rewire correctly.
			Locked mechanically	Repair if the Servomotor shaft is locked
			Control panel error	Replace the Servo Driver.
		Occurs when rotating at high speed.	Servomotor power or encoder line is miswired.	Rewire correctly.
		Occurs when long command pulses are sent.	Gain adjustment is insufficient.	Adjust the gain.
			Acceleration and deceleration is too violent.	Lengthen acceleration and deceleration time. Use position command filter (Pn207.0, Pn204, and Pn208).
Load is too large.		Lighten the load. Reselect the Servomotor.		
<i>A.d1</i>	Motor-load deviation over*	Occurs when the motor or full closed-loop encoder is rotating.	Pn002.3 (fully-closed encoder usage method) is not set correctly.	Correct the setting of Pn002.3.
			Pn206 (number of fully-closed encoder pulses) is not set correctly.	Correct the setting of Pn206.
			Pn51A (motor-load deviation over level) is not set correctly.	Correct the setting of Pn51A according to the machinery.
			The machinery is not operating properly.	Check the machinery.
			Slipping is occurring in the power transmission.	Set Pn51A to 0 so that A.d1 is not detected.
			Fully-closed encoder wiring error.	Wire the fully-closed encoder correctly.
			Fully-closed encoder is defective.	Replace the fully-closed encoder.
			Option Unit is defective.	Replace the Option Unit.

Display	Error	Status when error occurs	Cause of error	Countermeasures
R.E 7	Option detection error*	Occurs when the control circuit power supply is turned ON.	Option Unit has been removed.	Mount the Option Unit properly. Initialize the user parameters by executing Fn005, and clear the Option Unit detection results by executing Fn014 (if an Option Unit is not to be used).
			Option Unit is defective.	Replace the Option Unit.
			Servo Driver is defective.	Replace the Servo Driver.
R.F 1	Missing phase detected.	Occurs when servo is ON.	Main circuit power supply is not connected. Main circuit power supply phase is missing, or wire is burned out.	Check the main circuit power supply wiring.
R.F 5	Motor current error**	Occurs at startup (See note.)	Servomotor power line is not connected.	Correct the wiring.
			Servomotor power line is wired incorrectly or the connection is defective.	Check the Servomotor power line and correct the wiring.
			Servomotor power line is broken or defective, preventing current from flowing correctly to the Servomotor.	Check the conduction and resistance value, and replace the power line if it is defective.
			Servomotor is defective.	Replace the Servomotor.
			Servo Driver is defective.	Replace the Servo Driver.

Display	Error	Status when error occurs	Cause of error	Countermeasures
A.F6	Motor conduction error**	Occurs when servo is ON.	Servomotor power line is not connected.	Correct the wiring.
			Servomotor power line is wired incorrectly or the connection is defective.	Check the Servomotor power line and correct the wiring.
			Servomotor power line is broken or defective, preventing current from flowing correctly to the Servomotor.	Check the conduction and resistance value, and replace the power line if it is defective.
			Servomotor is defective.	Replace the Servomotor.
			Servo Driver is defective.	Replace the Servo Driver.
		Occurs at startup. (See note.)	Servomotor power line is not connected.	Correct the wiring.
			Servomotor power line is wired incorrectly or the connection is defective.	Check the Servomotor power line and correct the wiring.
			Servomotor power line is broken or defective, preventing current from flowing correctly to the Servomotor.	Check the conduction and resistance value, and replace the power line if it is defective.
			Servomotor is defective.	Replace the Servomotor.
			Servo Driver is defective.	Replace the Servo Driver.
			Occurs during operation.	Attempted to execute servo ON (motor current conduction) while motor is being controlled by the dynamic brake, such as when the servo is OFF or drive prohibit input is being used.
		Servo Driver is defective.		Replace the Servo Driver.
		Internal element misoperation		Reset the alarm, then restart the operation.
		Internal element is broken		Replace the Servo Driver.
		CPFD0	Parameter Unit transmission error 1	Occurs when power supply is turned ON.
CPFD1	Parameter Unit transmission error 2	Occurs when Parameter Unit is in use.	Internal element misoperation	Reset the alarm, then restart the operation.
			Internal element is broken	Replace the Servo Driver.

Note When the torque commands are less than 90% or when a torque limit of less than 90% is applied, A.F6 will occur instead of A.F5.

5-3-2 Troubleshooting by Means of Operating Status

Symptom	Probable cause	Items to check	Countermeasures	Control mode	
The power supply indicator (POWER) does not light even when the power supply is turned ON.	Power supply lines are incorrectly wired.	Check the power supply voltage. Check the power supply lines.	Correct the power supply. Correct the wiring.	All modes	
The Servomotor does not operate even when a command is given. (No alarm is output.)	The RUN signal is OFF.	Check the RUN signal's ON and OFF by means of the monitor mode (Un005).	Input the RUN signal. Correct the wiring.	All modes	
	The POT and NOT signals are OFF (except when Pn50A.3 and Pn50b.0 are set to 8).	Check whether POT and NOT are displayed in status display mode.	Turn ON the POT and NOT signals. If POT and NOT are not being used, set to "Always OFF" (Pn50A.3 and Pn50b.0 = 8).	All modes	
	The control mode is not right.	Check Pn000.1 (control mode selection)	Set the control mode to match the command type.	All modes	
	The deviation counter reset input (ECRST) is ON.	With monitor mode, check the ON/OFF status of the ECRST signal (Un005).	Pn200.1 (Deviation counter reset) setting is incorrect.	Reset Pn200.1 to match the Controller.	Position
			An error occurred with the RESET (alarm reset) signal ON.	Check the RESET signal's ON and OFF by means of the monitor mode.	Turn the RESET signal OFF and take measures according to the alarm display.
	Pn200.0 (Command pulse mode) setting is incorrect.	Check the Controller's command pulse type and the Servo Driver's command pulse mode.	Set the mode to match the Controller's command pulse type.	Position	
	The speed command (REF) voltage is 0 V.	Check the speed command by means of the monitor mode (Un001). Check the speed command voltage.	Correct the wiring.	Speed	
	The PLOCK signal is ON.	Check the PLOCK signal by means of the monitor mode (internal status bit).	Turn the PLOCK signal OFF. Check the Pn501 (Position lock rotation speed) value.	Speed	
	SEN (sensor ON) is turned OFF (when using an absolute encoder).	Check whether the SEN signal is ON or OFF using monitor mode.	Turn ON the SEN signal.	All modes	
The Servomotor operates momentarily, but then it does not operate.	The Servomotor power lines or encoder lines are wired incorrectly.	Check the Servomotor power line U, V, and W phases, and the encoder line wiring.	Correct the wiring.	All modes	

Symptom	Probable cause	Items to check	Countermeasures	Control mode
Servomotor operation is unstable.	The Servomotor power lines or encoder lines are wired incorrectly.	Check the Servomotor power line U, V, and W phases, and the encoder line wiring.	Correct the wiring.	All modes
	The bias function setting is incorrect.	---	Adjust Pn107 (bias rotational speed) and Pn108 (bias addition width).	Position
	The polarity of the speed command (REF) input is wrong.	Check the speed command input wiring.	Correct the wiring.	Speed
	There are eccentricities or looseness in the coupling connecting the Servomotor shaft and the mechanical system, or there are load torque fluctuations according to how the pulley gears are engaging.	Check the machinery. Try operating the Servomotor without a load.	Adjust the machinery.	All modes
	Gain is wrong.	---	Use auto-tuning. Adjust the gain manually.	Position Speed
Servomotor is overheating.	The ambient temperature is too high.	Check to be sure that the ambient temperature around the Servomotor is no higher than 40°C.	Lower the ambient temperature to 40°C or less. (Use a cooler or fan.)	All modes
	Ventilation is obstructed.	Check to see whether anything is blocking ventilation.	Ensure adequate ventilation.	All modes
	There is an overload.	Check the torque command value by means of monitor mode (Un002).	Lighten the load. Change to a larger capacity Servomotor and Servo Driver.	All modes
	The correspondence between the Servo Driver and the Servomotor is incorrect.	Check the models.	Combine models that correspond correctly.	All modes
There are unusual noises.	The machinery is vibrating.	Inspect the machinery to see whether there are any foreign objects in the movable parts, or whether there is any damage, deformation, or looseness.	Fix any problems causing vibration.	All modes
	Pn100 (Speed loop gain) is insufficient.	---	Use online auto-tuning. Adjust the gain manually (speed loop gain).	Position Speed
Vibration is occurring at the same frequency as the applicable power supply.	Inductive noise is occurring.	Check to see whether the Servo Driver control signal lines are too long. Check to see whether control signal lines and power supply lines are too close to each other.	Shorten the control signal lines. Separate control signal lines from power supply lines. Use a low-impedance power supply for control signals.	All modes
The Servomotor operates even when speed command is for 0 V.	The speed command voltage and the speed command input section are offset.	Check the speed command voltage.	Adjust the speed command offset (Fn009 or Fn00A). Use speed control mode with position lock function. (Control mode selection: Pn000.1 = A)	Speed

5-4 Overload Characteristics (Electron Thermal Characteristics)

An overload protection (electron thermal) function is built into the Servo Driver to protect against Servo Driver or Servomotor overload. If an overload (A.71 to A.72) does occur, first clear the cause of the error and then wait at least one minute for the Servomotor temperature to drop before turning on the power again. If the power is turned on again too soon, the Servomotor coil may be damaged.

Overload characteristics are shown in the following table. If, for example, a current of three times the Servomotor’s rated current flows continuously, it will be detected after approximately three seconds.

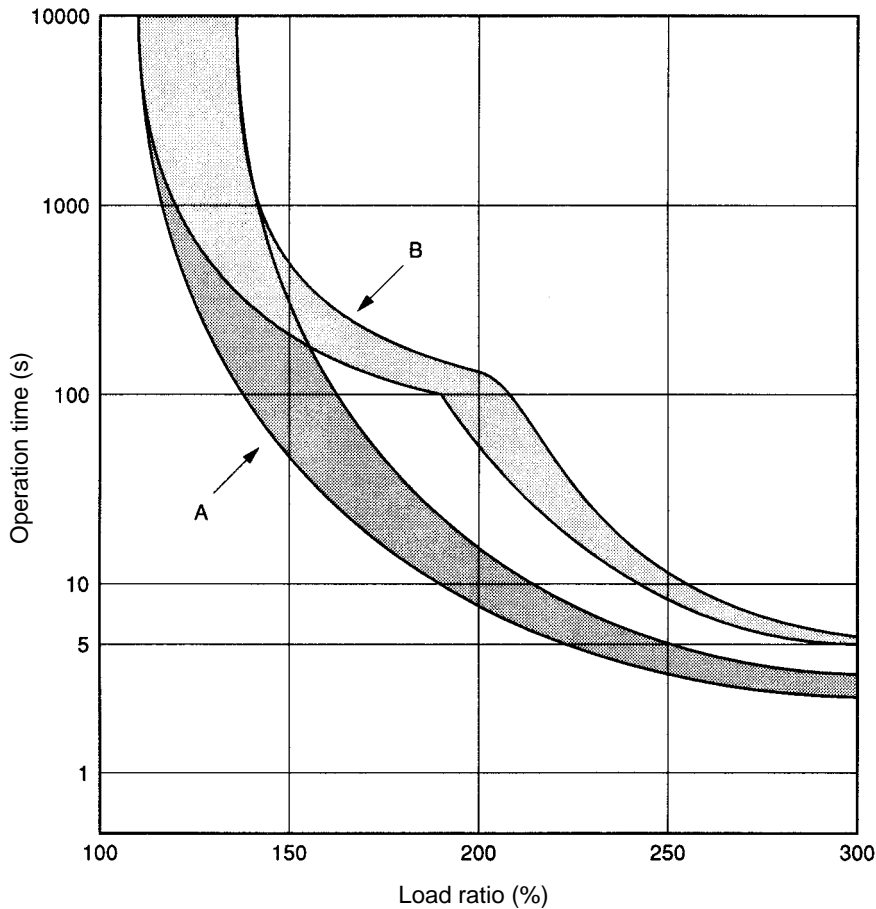

- A: 3,000 r/min.-Servomotors, 30 to 400 W
 3,000 r/min. Flat-style Servomotors, 100 to 400 W
- B: 3,000-r/min. Servomotors, 750W to 5 kW
 3,000-r/min. Flat-style Servomotors, 750 W to 1.5 kW
 1,000-r/min. Servomotors, 300 W to 5.5 kW
 1,500-r/min. Servomotors, 450 W to 15 kW

Note The load ratio is calculated in relation to the Servomotor’s rated current.

$$\text{Load ratio (\%)} = \frac{\text{Servomotor current}}{\text{Servomotor rated current}} \times 100$$

5-5 Periodic Maintenance

Maintenance and Inspection Precautions

⚠ WARNING Do not attempt to disassemble, repair, or modify any Units. Any attempt to do so may result in malfunction, fire, or electric shock.

⚠ Caution Resume operation only after transferring to the new Unit the contents of the data required for operation. Not doing so may result in an unexpected operation.

Servomotors and Servo Drivers contain many components and will operate properly only when each of the individual components is operating properly. Some of the electrical and mechanical components require maintenance depending on application conditions. In order to ensure proper long-term operation of Servomotors and Drivers, periodic inspection and part replacement is required according to the life of the components.

The periodic maintenance cycle depends on the installation environment and application conditions of the Servomotor or Driver. Recommended maintenance times are listed below for Servomotors and Drivers. Use these for reference in determining actual maintenance schedules.

■ Servomotors

- Recommended Periodic Maintenance

Bearings:	20,000 hours
Reduction gear:	20,000 hours
Oil seal:	5,000 hours

Application Conditions: Ambient Servomotor operating temperature of 40°C, within allowable shaft load, rated operation (rated torque and r/m), installed as described in operation manual.

- The radial loads during operation (rotation) on timing pulleys and other components contacting belts is twice the still load. Consult with the belt and pulley manufacturers and adjust designs and system settings so that the allowable shaft load is not exceeded even during operation. If a Servomotor is used under a shaft load exceeding the allowable limit, the Servomotor shaft can break, the bearings can burn out, and other problems can occur.

■ Servo Drivers

- Recommended Periodic Maintenance

Aluminum analytical capacitors: 50,000 hours, at an ambient Servo Driver operating temperature of 40°C, rated operation (rated torque), installed as described in operation manual.

Axle fan: 30,000 hours, at an ambient Servo Driver operating temperature of 40°C and an ambient humidity of 65%.

Absolute encoder backup battery:
50,000 hours, at an ambient Servo Driver operating temperature of 20°C.

- When using the Servo Driver under the continuous operation mode, cool the Servo Driver with fans and air conditioners to maintain an ambient operating temperature below 40°C.
- The life of aluminum analytical capacitors is greatly affected by the ambient operating temperature. Generally speaking, an increase of 10°C in the ambient operating temperature will reduce capacitor life by 50%. We recommend that ambient operating temperature be lowered and the power supply time be reduced as much as possible to lengthen the maintenance times for Servo Drivers.
- If the Servomotor or Servo Driver is not to be used for a long time, or if they are to be used under conditions worse than those described above, a periodic inspection schedule of five years is recommended. Please consult with OMRON to determine whether or not components need to be replaced.

5-6 Replacing the Absolute Encoder Battery (ABS)

Replace the absolute encoder backup battery if it has been used for at least five years, or if an A.93 (battery warning) warning or an A.83 (battery error) alarm occurs.

■ Battery Model and Specifications

Item	Specification
Name	Absolute Encoder Backup Battery Unit
Model numbers	R88A-BAT01W (For all Servo Drivers except R88D-WT60H to R88D-WT150H) R88A-BAT02W (For R88D-WT60H to R88D-WT150H)
Battery model	ER3V (Toshiba)
Battery voltage	3.6 V
Current capacity	1,000 mA•h

Note Refer to 2-10 *Absolute Encoder Backup Battery Specifications* for dimensions and wiring details.

■ Battery Replacement Procedure

- Replace the battery using the following replacement procedure. After replacing the battery, if a A.81 (backup error) alarm does not occur, the replacement is completed. If an A.81 alarm occurs, you need to set up the absolute encoder.

1. Turn ON the power supply to the Servo Driver's control circuit.

- Turn ON the power supply to the Servo Driver's control circuit only. This will supply power to the absolute encoder.

Note If an A.93 warning occurs when the power supply is ON, turn OFF only the main circuit power supply after completing operation and then perform the following replacement procedure. If the control circuit power supply is turned OFF, the absolute data in the absolute encoder may be inadvertently cleared.

2. Replace the battery.

- Remove the old battery from the Servo Driver's battery holder, and disconnect the connector to the battery from the battery connector CN8.
- Place the new battery in the battery holder, and insert the connector correctly into battery connector CN8.

3. Turn the power supply OFF, then ON again.

- After correctly connecting the new battery, turn OFF the power supply to the Servo Driver, then turn it ON again.
- If a Servo Driver alarm is not displayed, battery replacement is completed.

Note If A.81 (backup error) is displayed, you need to set up the absolute encoder. Refer to 4-2-2 *Absolute Encoder Setup and Battery Changes*, and perform the setup and make the initial settings for the Motion Control Unit.

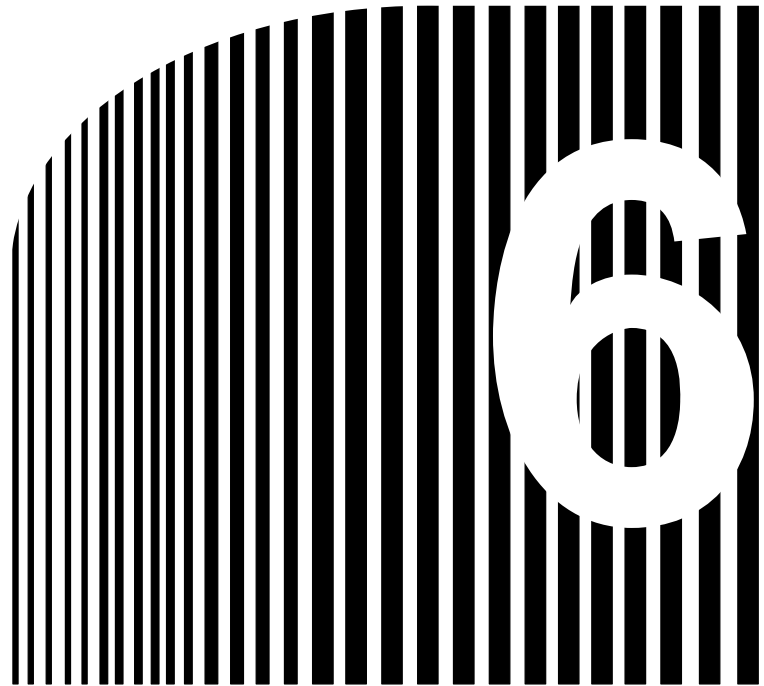

Chapter 6

• Appendix •

- 6-1 Connection Examples
- 6-2 Encoder Dividing Rate for Servo Controllers
- 6-3 Single-phase Power for 3,000-r/min (750-W) Servomotors
- 6-4 Parameter Setting Tables
- 6-5 Alarms and Warnings when a JUSP-NS115 MECHATROLINK-II Option Unit is Mounted

6-1 Connection Examples

■ Connection Example 1: Connecting to SYSMAC CJ1W-NC113/213/413 Position Control Units

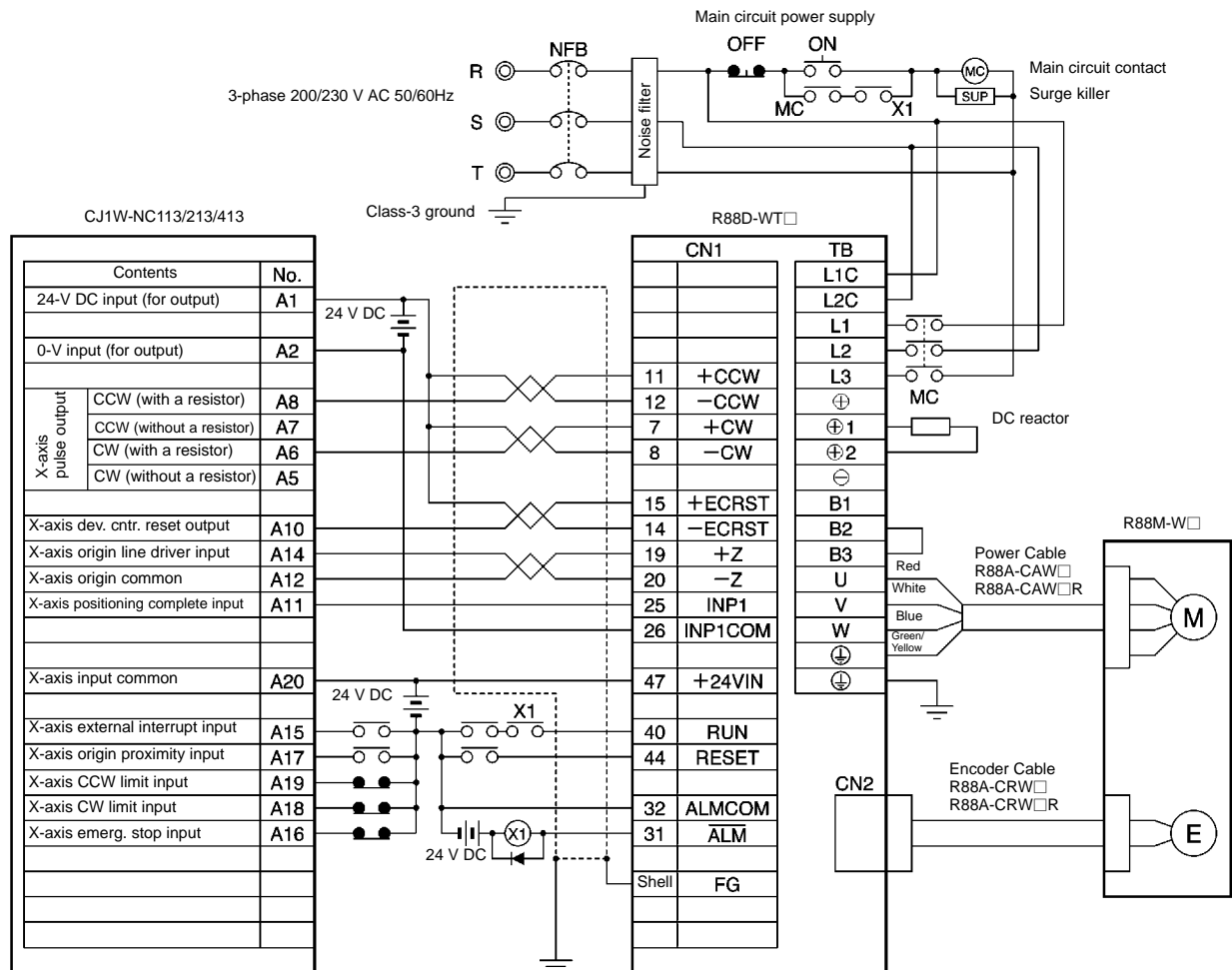

- Note 1.** The example shows a three-phase, 200-V AC input to the Servo Driver for the main circuit power supply. Be sure to provide a power supply and wiring conforming to the power supply specifications for the Servo Driver in use.
- Note 2.** Incorrect signal wiring can cause damage to Units and the Servo Driver.
- Note 3.** Leave unused signal lines open and do not wire them.
- Note 4.** Use mode 2 for origin search.
- Note 5.** Use the 24-V DC power supply for command pulse signals as a dedicated power supply.
- Note 6.** The diode recommended for surge absorption is the ERB44-02 (Fuji Electric).
- Note 7.** Make the setting so that the Servo can be turned ON and OFF with the RUN signal.

■ Connection Example 2: Connecting to SYSMAC CJ1W-NC133/233/433 Position Control Units

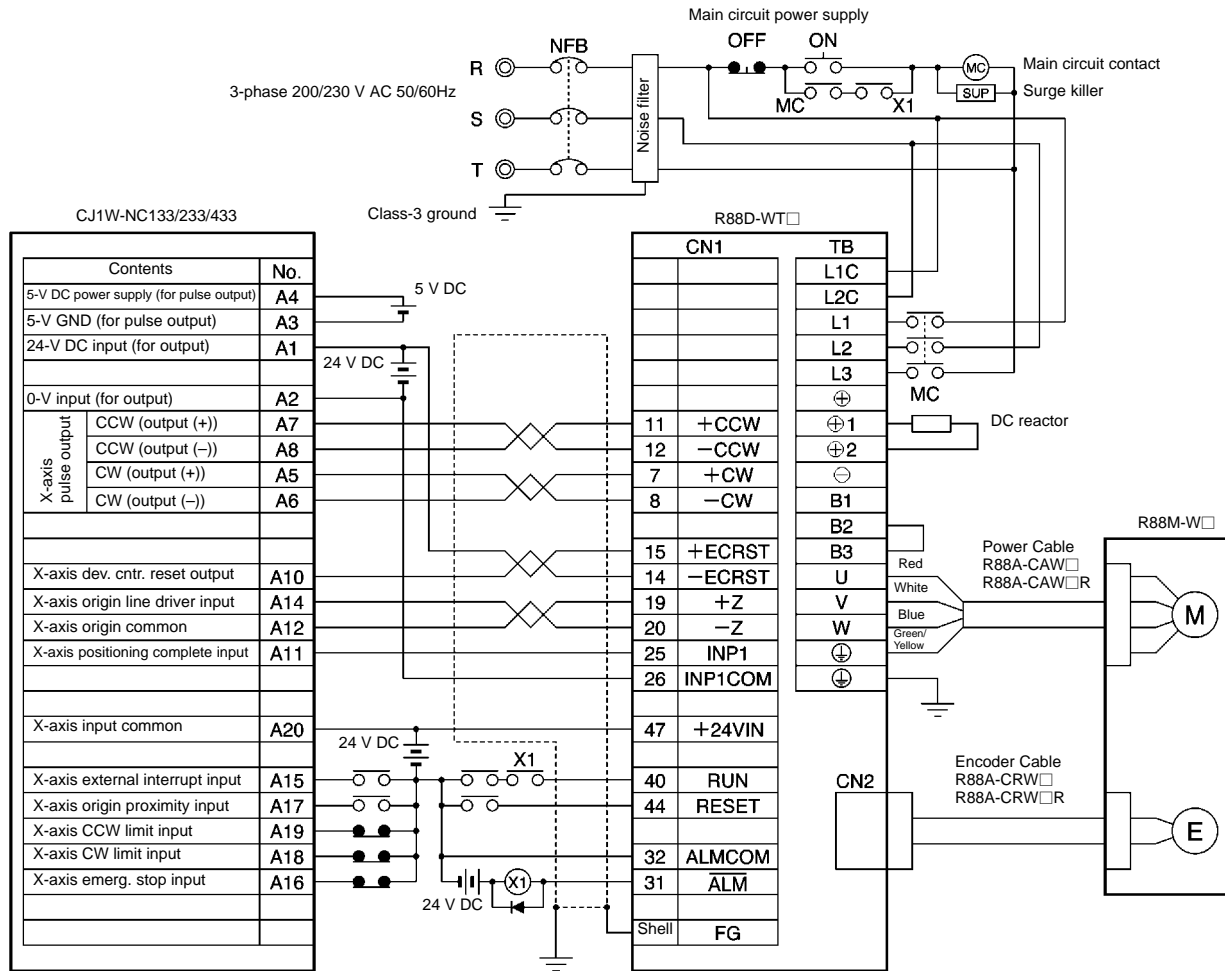

- Note 1.** The example shows a three-phase, 200-V AC input to the Servo Driver for the main circuit power supply. Be sure to provide a power supply and wiring conforming to the power supply specifications for the Servo Driver in use.
- Note 2.** Incorrect signal wiring can cause damage to Units and the Servo Driver.
- Note 3.** Leave unused signal lines open and do not wire them.
- Note 4.** Use mode 2 for origin search.
- Note 5.** Use the 5-V DC power supply for command pulse signals as a dedicated power supply.
- Note 6.** The diode recommended for surge absorption is the ERB44-02 (Fuji Electric).
- Note 7.** Make the setting so that the Servo can be turned ON and OFF with the RUN signal.

■ Connection Example 4: Connecting to SYSMAC CS1W-NC133/233/433 Position Control Units

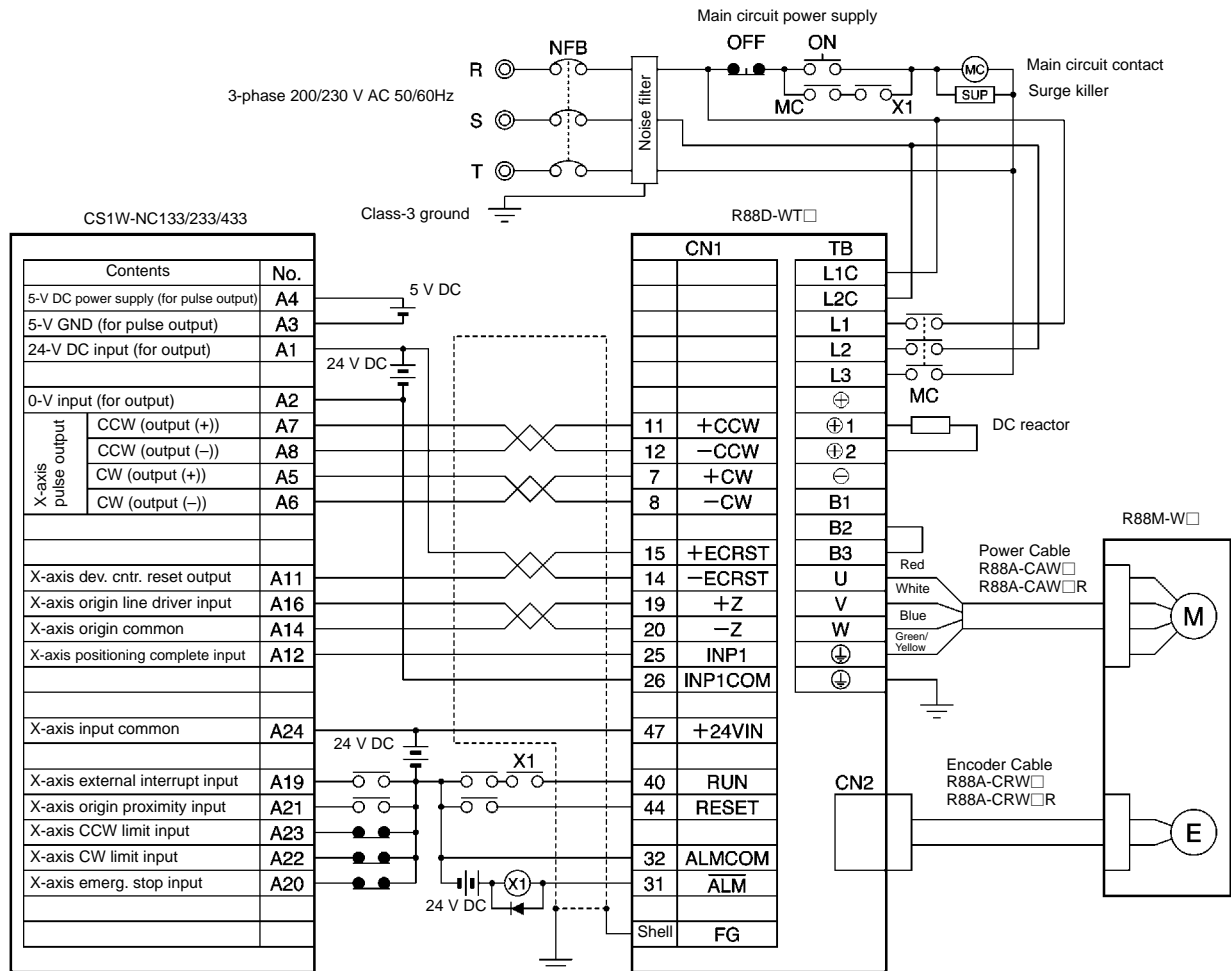

- Note 1.** The example shows a three-phase, 200-V AC input to the Servo Driver for the main circuit power supply. Be sure to provide a power supply and wiring conforming to the power supply specifications for the Servo Driver in use.
- Note 2.** Incorrect signal wiring can cause damage to Units and the Servo Driver.
- Note 3.** Leave unused signal lines open and do not wire them.
- Note 4.** Use mode 2 for origin search.
- Note 5.** Use the 5-V DC power supply for command pulse signals as a dedicated power supply.
- Note 6.** The diode recommended for surge absorption is the ERB44-02 (Fuji Electric).
- Note 7.** Make the setting so that the Servo can be turned ON and OFF with the RUN signal.

■ Connection Example 5: Connecting to 3F88M-DRT141 DeviceNet Single-axis Positioner

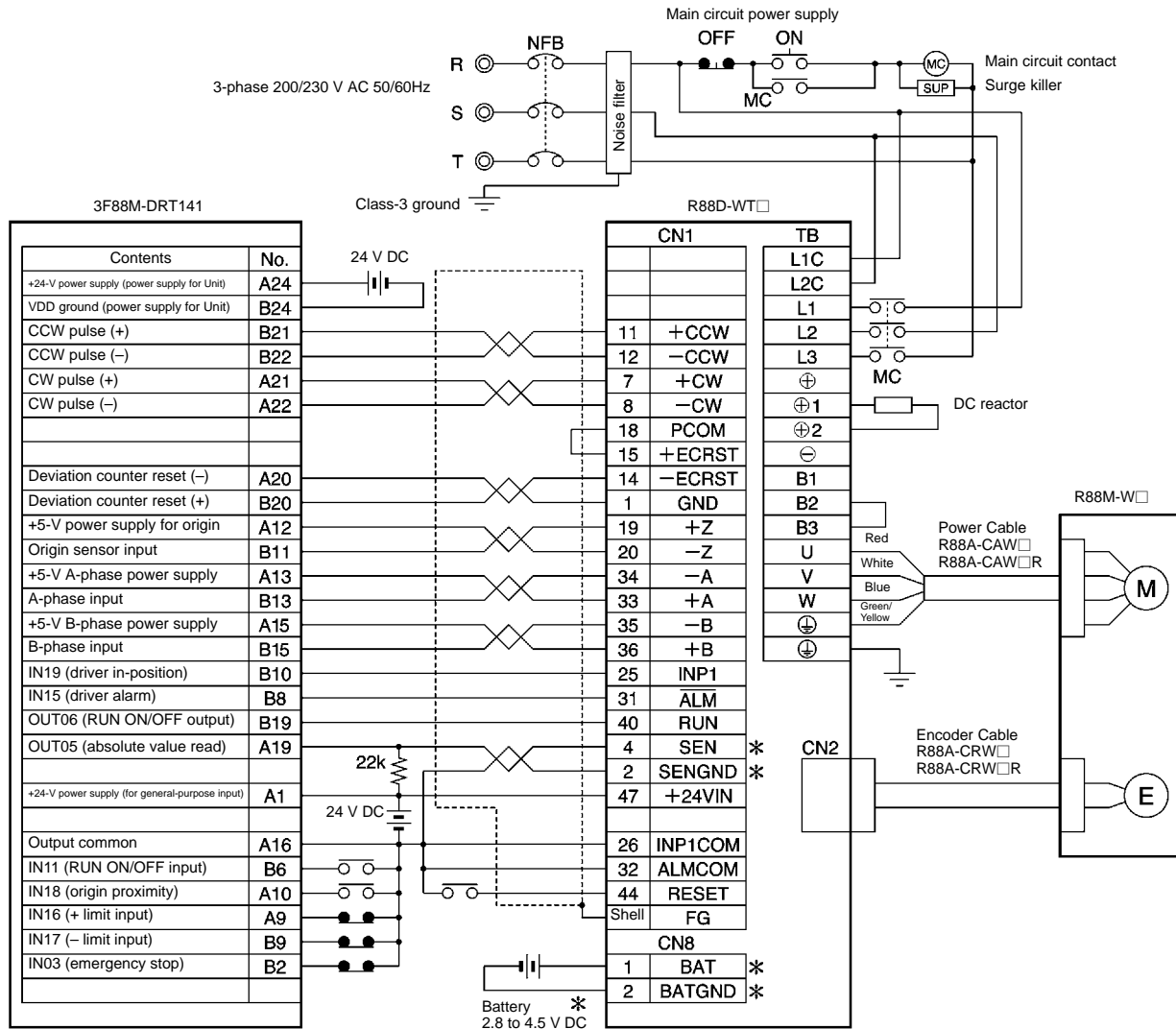

- Note 1.** The example shows a three-phase, 200-V AC input to the Servo Driver for the main circuit power supply. Be sure to provide a power supply and wiring conforming to the power supply specifications for the Servo Driver in use.
- Note 2.** Incorrect signal wiring can cause damage to Units and the Servo Driver.
- Note 3.** Leave unused signal lines open and do not wire them.
- Note 4.** The diode recommended for surge absorption is the ERB44-02 (Fuji Electric).
- Note 5.** Make the setting so that the Servo can be turned ON and OFF with the RUN signal.
- Note 6.** General-purpose I/O is one allocation example. The emergency stop, limit input, and driver alarm contacts are NC and the driver in-position, origin proximity, RUN ON/OFF input, RUN ON/OFF output, and absolute value read contacts are NO.
- Note 7.** Connect the terminals and wiring marked with an asterisk (*) when using an Absolute Encoder.
- Note 8.** Use command pulse output in the line driver output setting.

■ Connection Example 6: Connecting to SYSMAC C200H-NC112 Position Control Units

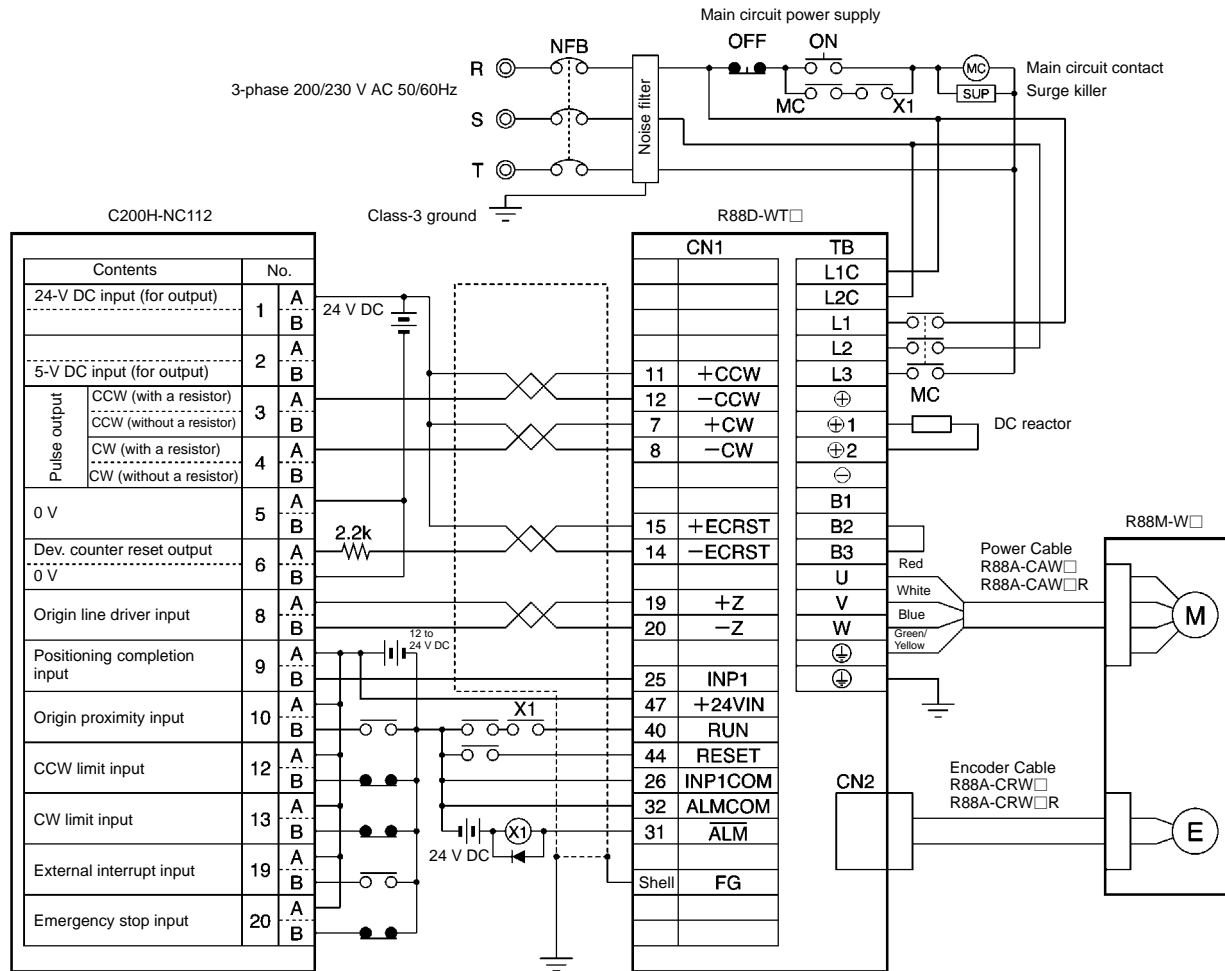

- Note 1.** The example shows a three-phase, 200-V AC input to the Servo Driver for the main circuit power supply. Be sure to provide a power supply and wiring conforming to the power supply specifications for the Servo Driver in use.
- Note 2.** Incorrect signal wiring can cause damage to Units and the Servo Driver.
- Note 3.** Leave unused signal lines open and do not wire them.
- Note 4.** Use mode 2 for origin search.
- Note 5.** Use the 24-V DC power supply for command pulse signals as a dedicated power supply.
- Note 6.** The diode recommended for surge absorption is the ERB44-02 (Fuji Electric).
- Note 7.** Make the setting so that the Servo can be turned ON and OFF with the RUN signal.

■ Connection Example 7: Connecting to SYSMAC C200H-NC211/C500-NC113/211 Position Control Units

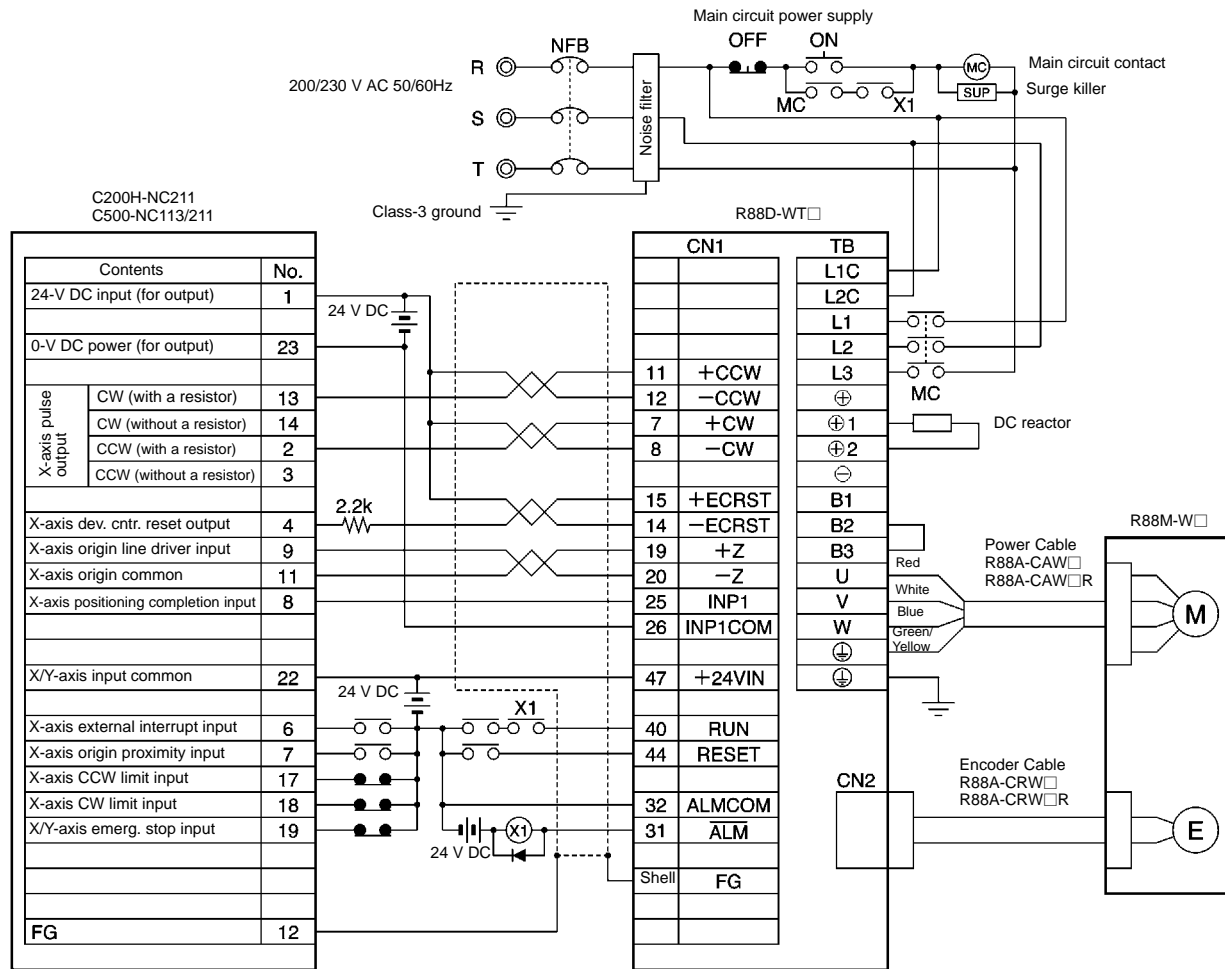

- Note 1.** The example shows a 3-phase, 200-V AC input to the Servo Driver for the main circuit power supply. Be sure to provide a power supply and wiring conforming to the power supply specifications for the Servo Driver in use.
- Note 2.** Incorrect signal wiring can cause damage to Units and the Servo Driver.
- Note 3.** Leave unused signal lines open and do not wire them.
- Note 4.** Use mode 2 for origin search.
- Note 5.** Use the 24-V DC power supply for command pulse signals as a dedicated power supply.
- Note 6.** The diode recommended for surge absorption is the ERB44-02 (Fuji Electric).
- Note 7.** This wiring diagram is for the X axis only. If the other axis is to be used, connect to the Servo Driver in the same way.
- Note 8.** Make the setting so that the Servo can be turned ON and OFF with the RUN signal.

■ Connection Example 8: Connecting to SYSMAC C500-NC222-E Position Control Units

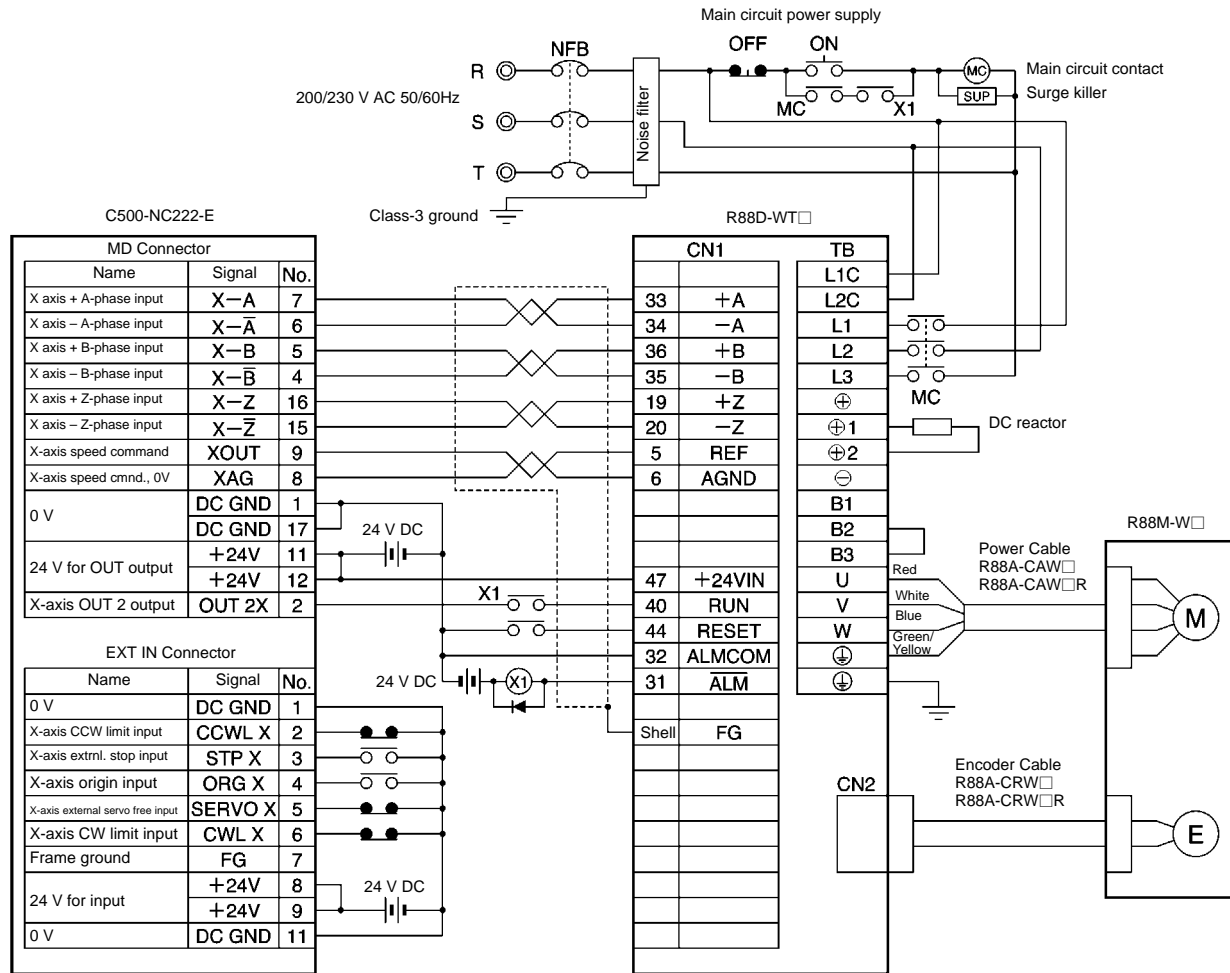

- Note 1.** The example shows a 3-phase, 200-V AC input to the Servo Driver for the main circuit power supply. Be sure to provide a power supply and wiring conforming to the power supply specifications for the Servo Driver in use.
- Note 2.** Incorrect signal wiring can cause damage to Units and the Servo Driver.
- Note 3.** Leave unused signal lines open and do not wire them.
- Note 4.** The diode recommended for surge absorption is the ERB44-02 (Fuji Electric).
- Note 5.** This wiring diagram is an example of X-axis wiring only. For two-axis control, the external input and Driver wiring must be connected for the Y axis in the same way.
- Note 6.** External output 2 (OUT-2X) can be turned ON and OFF with external servo-unlocked input, at which time external output 2 of the C500-NC222-E's address numbers 420 (X axis) and 820 (Y axis) must be set to 1 (turned OFF at the time of servo free).
- Note 7.** When the C500-NC222-E is used in NC221 mode, external servo-unlocked input works as emergency stop input. Therefore external output 2 cannot be used as a RUN signal. Input a RUN signal from other I/O terminals.
- Note 8.** Make the setting so that the Servo can be turned ON and OFF with the RUN signal.

■ Connection Example 9: Connecting to SYSMAC Motion Control Units

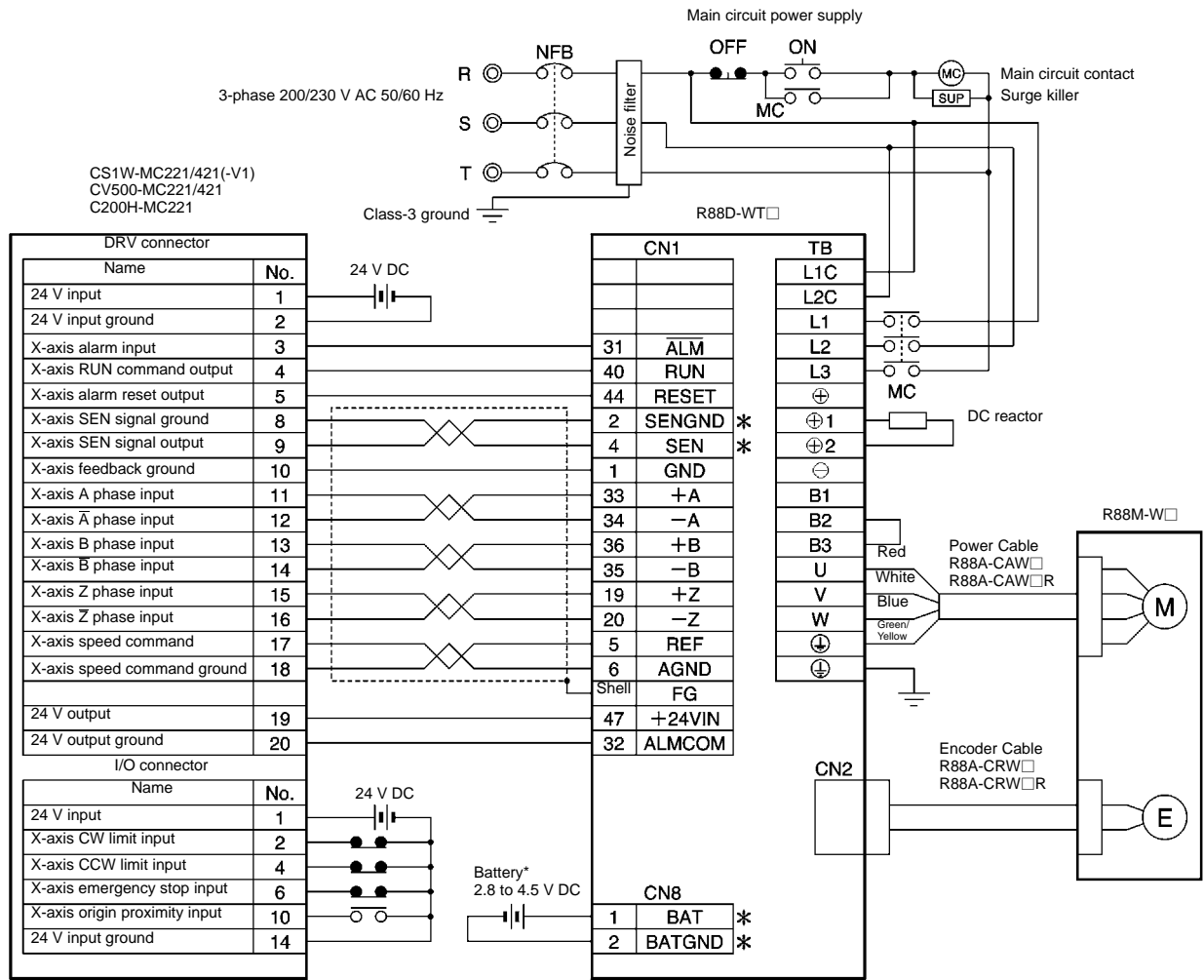

- Note 1.** The example shows a three-phase, 200-V AC input to the Servo Driver for the main circuit power supply. Be sure to provide a power supply and wiring conforming to the power supply specifications for the Servo Driver in use.
- Note 2.** Incorrect signal wiring can cause damage to Units and the Servo Driver.
- Note 3.** Leave unused signal lines open and do not wire them.
- Note 4.** Connect terminals and wiring marked with an asterisk (*) when using an Absolute Encoder.
- Note 5.** This wiring diagram is an example of X-axis wiring only. For two-axis control, the external input and Driver wiring must be connected for the Y axis in the same way.
- Note 6.** Always short NC I/O terminals that are not used among the Motion Control Unit's I/O connectors.
- Note 7.** Make the setting so that the Servo can be turned ON and OFF with the RUN signal.

■ Connection Example 10: Connecting to a SYSMAC CS1W-HCP22-V1 Customizable Counter Unit

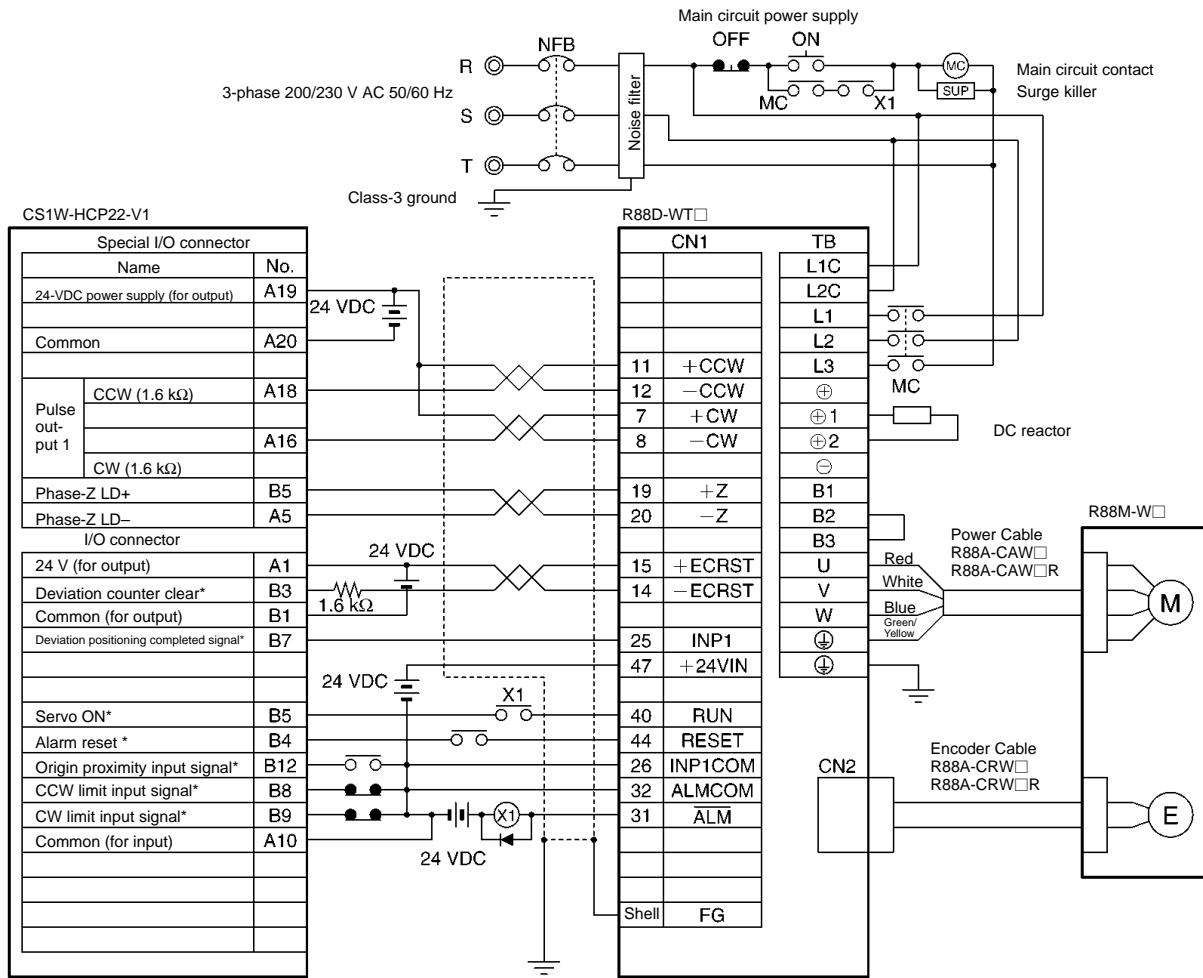

- Note 1.** Incorrect signal wiring can cause damage to Units and the Servo Driver.
- Note 2.** Leave unused signal lines open and do not wire them.
- Note 3.** Use the 24-V DC power supply for command pulse signals as a dedicated power supply.
- Note 4.** The diode recommended for surge absorption is the ERB44-02 (Fuji Electric) or equivalent.
- Note 5.** Do not share the 24-V DC power supply for the brake with the 24-V DC power supply for control.

* The I/O signals of the CS1W-HCP22-V1 depend on the internal memory area allocations. Change the wiring according to the allocations.

■ Connection Example 11: Connecting to a SYSMAC CS1W-HCA12/22-V1 Customizable Counter Unit

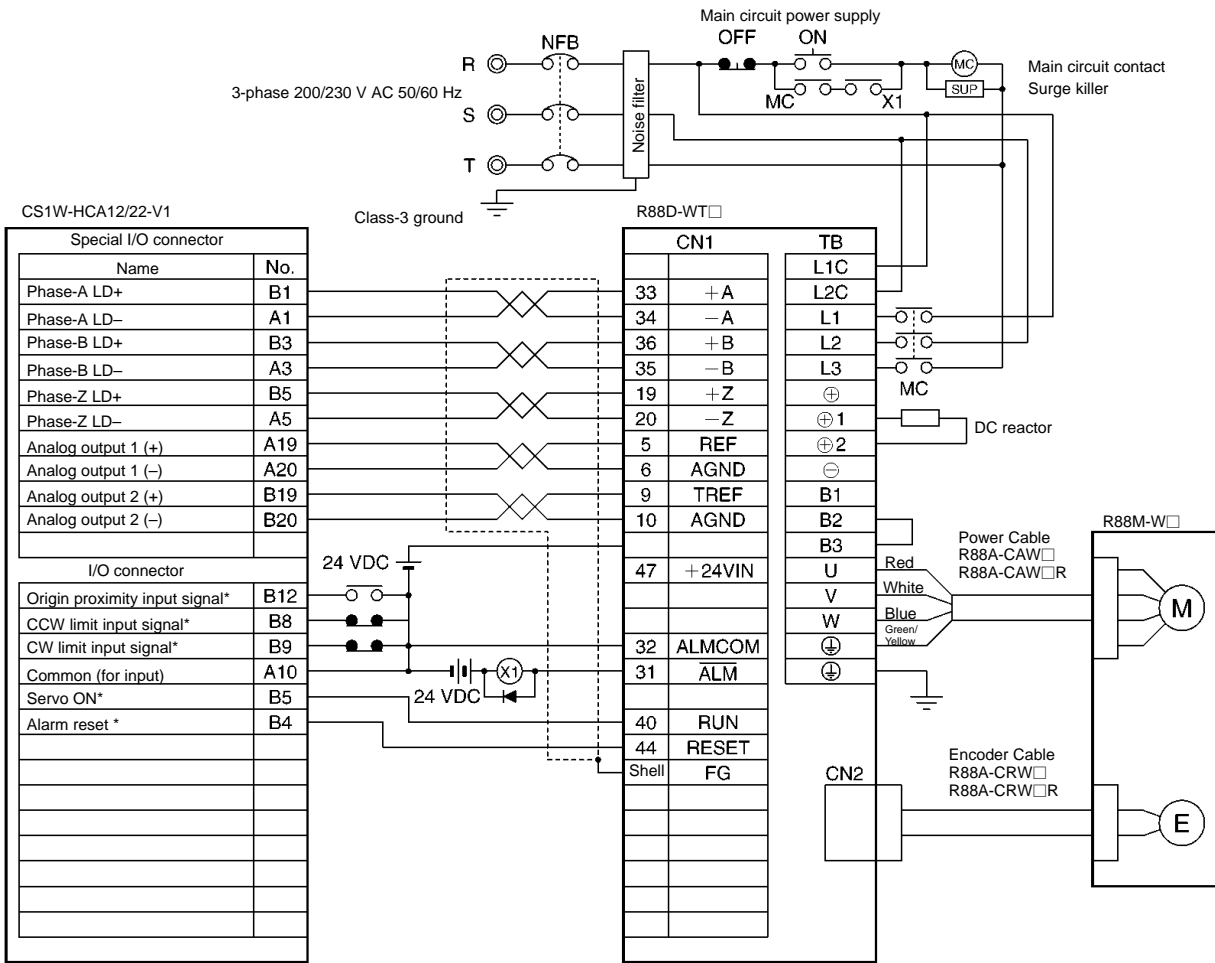

- Note 1.** Incorrect signal wiring can cause damage to Units and the Servo Driver.
- Note 2.** Leave unused signal lines open and do not wire them.
- Note 3.** Use the 24-V DC power supply for command pulse signals as a dedicated power supply.
- Note 4.** The diode recommended for surge absorption is the ERB44-02 (Fuji Electric) or equivalent.
- Note 5.** Do not share the 24-V DC power supply for the break with the 24-V DC power supply for control.

* The I/O signals of the CS1W-HCP22-V1 depend on the internal memory area allocations. Change the wiring according to the allocations.

6-2 Encoder Dividing Rate for Servo Controllers

Encoder output pulses for OMNUC W-Series AC Servo Drivers can be set within a range of 16 to 16,384 pulses/revolution by setting the encoder dividing rate. Depending on the Controller's encoder input maximum response frequency limits, however, the maximum numbers of revolutions are limited as shown in the following tables.

■ Encoder Divider Rates (Pn201)

Parameter No.	Parameter name	Explanation	Factory setting	Unit	Setting range	Restart power?
Pn201	Encoder divider rate setting	Sets the number of output pulses from the Servo Driver	1,000	Pulses/r	16 to 16,384	Yes

■ Encoder Divider Rates (Pn201) and Maximum Rotation Speed (r/min)

Model	16,384 to 8,193		8,192 to 4,097		4,096 to 2,049		2,048 to 1,025		1,024 max.	
	4	2, 1	4	2, 1	4	2, 1	4	2, 1	4	2, 1
CS1W-MC221/421(-V1)	1,831		3,662		5,000		5,000		5,000	
C200H-MC221	915		1,831		3,662		5,000		5,000	
CV500-MC221/421	622		1,245		2,490		4,980		5,000	
C500-NC222	366	457	732	915	1,464	1,831	2,929	3,662	5,000	

Note 1. In this table, the dividing rates are shown in the top line above the multipliers.

Note 2. For example, if operating a CS1W-MC221/421(-V1) at 5,000 r/min., set Pn201 (Encoder divider rate) to 4,096 (pulses/r) maximum.

6-3 Single-phase Power for 3,000-r/min (750-W) Servomotors

When using 3000-r/min (750-W) Servomotors, normally three-phase, 200-VAC power is required, but these Servomotors can also be operated using single-phase power if the following conditions are met.

This section describes wiring methods and precautions when using the 3000-r/min (750-W) Servomotors with a single-phase power supply

■ Applicable Servomotors

- 3,000-r/min (750-W) Servomotors: R88M-W75030H and R88M-W75030T
- 3,000-r/min (750-W) Flat Type Servomotors: R88M-WP75030H and R88M-WP75030T

■ Applicable Servo Drivers

- Three-phase, 200-VAC power: R88D-WT08H (750 W)

■ Wiring

- Connect the main-circuit power supply inputs L1, L2, and L3, as shown in the following diagram.

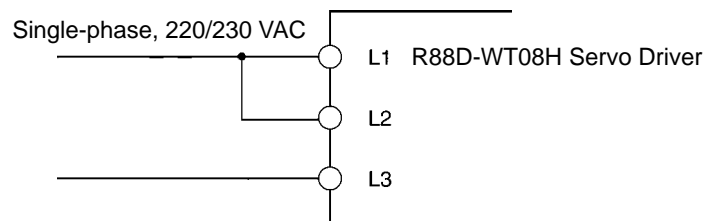

Note If the above wiring connections are not used, a missing phase detected alarm (A.F1) will occur.

■ Power Supply Voltage

- When the R88D-WT08H Servo Driver is used with a three-phase, 200-VAC power supply, the main-circuit power supply voltage range is 200/230 VAC -15% to $+10\%$ (170 to 253 V), 50/60 Hz. With single-phase power supply, the voltage range is 220/230 VAC -15% to $+10\%$ (187 to 253 V), 50/60 Hz.
- When the voltage is lower than 187 VAC (-15% of 220 VAC), an insufficient voltage alarm (A.41) may occur in the range above the rated output.
- The power supply capacity is 2.1 kVA. The rated current of the main-circuit power supply is 9.4 A (rms).

6-4 Parameter Setting Tables

Note 1. Parameters marked with one asterisk are for the DeviceNet Option Unit. Do not change the settings of these parameters unless a DeviceNet Option Unit is mounted.

Note 2. Parameters marked with two asterisks are supported for Servo Drivers with a software version of “r.0037.”

■ Function Selection Parameters (From Pn000)

Parameter No.	Parameter name	Digit No.	Name	Setting	Explanation	Default setting	Unit	Setting range	Restart power?
Pn000	Function selection basic switch	0	Reverse rotation	0	CCW direction is taken for positive command	0010	---	---	Yes
				1	CW direction is taken for positive command				
		1	Control mode selection	0	Speed control by analog command				
				1	Position control by pulse train command				
				2	Torque control by analog command				
				3	Internally set speed control				
				4	Switches between internally set speed control and speed control				
				5	Switches between internally set speed control and position control				
				6	Switches between internally set speed control and torque control				
				7	Switches between position control and speed control				
				8	Switches between position control and torque control				
				9	Switches between torque control and speed control				
				A	Speed control with position lock				
				b	Position control with pulse prohibition				
2	Unit No. setting	0 to F	Servo Driver communications unit number setting (necessary for multiple Servo Driver connections when using personal computer monitoring software)						
3	Not used.	0	(Do not change setting.)						

Parameter No.	Parameter name	Digit No.	Name	Setting	Explanation	Default setting	Unit	Setting range	Restart power?						
Pn001	Function selection application switch 1	0	Select stop if an alarm occurs when Servomotor is OFF	0	Servomotor stopped by dynamic brake.	1002	---	---	Yes						
				1	Servomotor stopped by dynamic brake, and then dynamic brake turned OFF after Servomotor stopped.										
				2	Servomotor stopped with free run.										
		1	Select stop when prohibited drive is input	0	Stop according to Pn001.0 setting (release Servomotor after stopping)										
				1	Stop Servomotor using torque set in Pn406, and lock Servomotor after stopping.										
				2	Stop Servomotor using torque set in Pn406, and release Servomotor after stopping.										
		2	Select AC/DC power input	0	AC power supply: AC power supplied from L1, L2, (L3) terminals										
				1	DC power supply: DC power from +1, - terminals										
		3	Select warning code output	0	Alarm code only output from ALO1, ALO2, ALO3										
				1	Alarm code and warning code output from ALO1, ALO2, ALO3										
		Pn002	Function selection application switch 2	0	Torque command input change (during position and speed control)					0	Not used.	0000	---	---	Yes
										1	Use TREF as analog torque limit input.				
2	Use TREF as torque feed forward input.														
3	Use TREF as analog torque limit when PCL and NCL are ON.														
1	Speed command input change (during torque control)			0	Not used.										
				1	Use REF as analog speed limit input.										
2	Operation switch when using absolute encoder			0	Use as absolute encoder.										
				1	Use as incremental encoder.										
3	Fully-closed encoder usage method*			0	Fully-closed encoder is not used.										
				1	Fully-closed encoder is used without phase Z.										
				2	Fully-closed encoder is used with phase Z.										
				3	Fully-closed encoder is used in Reverse Rotation Mode without phase Z.										
4	Fully-closed encoder is used in Reverse Rotation Mode with phase Z.														

Parameter No.	Parameter name	Digit No.	Name	Setting	Explanation	Default setting	Unit	Setting range	Restart power?
Pn003	Function selection application switch 3	0	Analog monitor 1 (AM) allocation	0	Servomotor rotation speed: 1 V/1000 r/min	0002	---	---	---
				1	Speed command: 1 V/1000 r/min				
				2	Torque command: 1 V/100%				
				3	Position deviation: 0.05 V/1 command unit				
				4	Position deviation: 0.05 V/100 command units				
				5	Command pulse frequency: 1 V/1000 r/min				
				6	Servomotor rotation speed: 1 V/250 r/min				
				7	Servomotor rotation speed: 1 V/125 r/min				
		8 to F	Not used.						
1	Analog monitor 2 (NM) allocation	0 to F	Same as Pn003.0						
2 to 3	Not used.	0	(Do not change setting.)						
Pn004	Not used.	---		---	(Do not change setting.)	0000	---	---	---
Pn005	Not used.	---		---	(Do not change setting.)	0000	---	---	---

■ Servo Gain Parameters (From Pn100)

Parameter No.	Parameter name	Explanation (See note 1.)				Default setting	Unit	Setting range	Restart power?
		Digit No.	Name	Setting	Explanation (See note 2.)				
Pn100	Speed loop gain	Adjusts speed loop responsiveness.				80	Hz	1 to 2000	---
Pn101	Speed loop integration constant	Speed loop integral time constant				2000	x 0.01 ms	15 to 51200	---
Pn102	Position loop gain	Adjusts position loop responsiveness.				40	1/s	1 to 2000	---
Pn103	Inertia ratio	Set using the ratio between the machine system inertia and the Servomotor rotor inertia.				300	%	0 to 20000 (See note 3.)	---
Pn104	Speed loop gain 2	Adjusts speed loop responsiveness (enabled by gain switching input).				80	Hz	1 to 2000	---
Pn105	Speed loop integration constant 2	Speed loop integral time constant (enabled by gain switching input).				2000	x 0.01 ms	15 to 51200	---
Pn106	Position loop gain 2	Adjusts position loop responsiveness (enabled by gain switching input).				40	1/s	1 to 2000	---
Pn107	Bias rotational speed	Sets position control bias.				0	r/min	0 to 450	---

Parameter No.	Parameter name	Explanation (See note 1.)				Default setting	Unit	Setting range	Restart power?
		Digit No.	Name	Setting	Explanation (See note 2.)				
Pn108	Bias addition band	Sets the position control bias operation start using deviation counter pulse width.				7	Command unit	0 to 250	---
Pn109	Feed-forward amount	Position control feed-forward compensation value				0	%	0 to 100	---
Pn10A	Feed-forward command filter	Sets position control feed-forward command filter.				0	x 0.01 ms	0 to 6400	---
Pn10b	Speed control setting	0	P control switching conditions	0	Sets internal torque command value conditions (Pn10C).	0004	---	---	Yes
				1	Sets speed command value conditions (Pn10d).				
				2	Sets acceleration command value conditions (Pn10E)				
				3	Sets deviation pulse value conditions (Pn10F)				
				4	No P control switching function				
		1	Speed control loop switching	0	PI control				
				1	IP control				
		2	Automatic gain switching selection**	0	Automatic gain switching disabled				
				1	Gain switching using position commands				
				2	Gain switching using position deviation				
		3	Not used.	0	(Do not change setting.)				

Parameter No.	Parameter name	Explanation (See note 1.)				Default setting	Unit	Setting range	Restart power?
		Digit No.	Name	Setting	Explanation (See note 2.)				
Pn110	Online auto-tuning setting	0	Selects online auto-tuning	0	Auto-tunes initial operations only after power is turned ON.	0012	---	---	Yes
				1	Always auto-tunes.				
				2	No auto-tuning				
		1	Selects speed feedback compensation function	0	ON				
				1	OFF				
		2	Selects adhesive friction compensation function	0	Friction compensation: OFF				
				1	Friction compensation: rated torque ratio small				
				2	Friction compensation: rated torque ratio large				
		3	Not used.	0	(Do not change setting.)				
Pn111	Speed feedback compensating gain	Adjusts speed loop feedback gain.				100	%	1 to 500	---
Pn112	Not used.	(Do not change setting.)				100	---	---	---
Pn113	Not used.	(Do not change setting.)				1000	---	---	---
Pn114	Not used.	(Do not change setting.)				200	---	---	---
Pn115	Not used.	(Do not change setting.)				32	---	---	---
Pn116	Not used.	(Do not change setting.)				16	---	---	---
Pn117	Not used.	(Do not change setting.)				100	---	---	---
Pn118	Not used.	(Do not change setting.)				100	---	---	---
Pn119	Not used.	(Do not change setting.)				50	---	---	---
Pn11A	Not used.	(Do not change setting.)				1000	---	---	---
Pn11b	Not used.	(Do not change setting.)				50	---	---	---
Pn11C	Not used.	(Do not change setting.)				70	---	---	---
Pn11d	Not used.	(Do not change setting.)				100	---	---	---
Pn11E	Not used.	(Do not change setting.)				100	---	---	---
Pn11F	Not used.	(Do not change setting.)				0	---	---	---
Pn120	Not used.	(Do not change setting.)				0	---	---	---
Pn121	Not used.	(Do not change setting.)				50	---	---	---
Pn122	Not used.	(Do not change setting.)				0	---	---	---
Pn123	Not used.	(Do not change setting.)				0	---	---	---
Pn124**	Automatic gain switching timer	Sets the switching delay after conditions have been met when the automatic gain switching function is used (Pn10b.2=1 to 3).				100	ms	1 to 10000	---
Pn125**	Automatic gain switching width (amount of position deviation)	Sets the position deviation used as the switching condition when the automatic gain switching function by position deviation (Pn10b.2 = 2, 3) is used.				7	Command unit	1 to 250	---

Note 1. Explanation for parameters set using 5 digits.

Note 2. Explanation for parameters requiring each digit No. to be set separately.

Note 3. The setting range is 0 to 10,000 for Servo Drivers with a software version of "r.0014" or earlier.

■ Position Control Parameters (From Pn200)

Parameter No.	Parameter name	Explanation (See note 1.)				Default setting	Unit	Setting range	Restart power?
		Digit No.	Name	Setting	Explanation (See note 2.)				
Pn200	Position control setting 1	0	Command pulse mode	0	Feed pulse forward/reverse signal: Positive logic	1011	---	---	Yes
				1	Forward pulse/reverse pulse: Positive logic				
				2	90° phase difference (A/B phase) signal (x1): Positive logic				
				3	90° phase difference (A/B phase) signal (x2): Positive logic				
				4	90° phase difference (A/B phase) signal (x4): Positive logic				
				5	Feed pulses/Forward/reverse signal: Negative logic				
				6	Forward pulse/reverse pulse: Negative logic				
				7	90° phase difference (A/B phase) signal (x1): Negative logic				
				8	90° phase difference (A/B phase) signal (x2): Negative logic				
				9	90° phase difference (A/B phase) signal (x4): Negative logic				
		1	Deviation counter reset	0	High level signal				
				1	Rising signal (low to high)				
				2	Low level signal				
				3	Falling signal (low to high)				
		2	Deviation counter reset if an alarm occurs when the Servomotor is OFF	0	Deviation counter reset if an alarm occurs when Servomotor is OFF.				
				1	Deviation counter not reset if an alarm occurs when Servomotor is OFF.				
				2	Deviation counter reset only if alarm occurs.				
		3	Pulse command filter selection	0	Command filter for line driver signal input (500 kpps)				
				1	Command filter for open-collector signal input (200 kpps)				
Pn201	Encoder divider rate setting	Sets the number of output pulses from the Servo Driver.				1000	pulse/rotation	16 to 16384	Yes
Pn202	Electronic gear ratio G1 (numerator)	Sets the pulse rate for the command pulses and Servomotor travel distance. $0.01 \leq G1/G2 \leq 100$				4	---	1 to 65535	Yes
Pn203	Electronic gear ratio G2 (denominator)					1	---	1 to 65535	Yes

Parameter No.	Parameter name	Explanation (See note 1.)				Default setting	Unit	Setting range	Restart power?
		Digit No.	Name	Setting	Explanation (See note 2.)				
Pn204	Position command filter time constant 1 (primary filter)	Sets soft start for command pulse. (Soft start characteristics are for the primary filter.)				0	x 0.01 ms	0 to 6400	---
Pn205	Absolute encoder multi-turn limit setting	Sets the limit to the number of rotations when using a Servomotor with an absolute encoder.				65535	rotations	0 to 65535	Yes
Pn206 *	Number of fully-closed encoder pulses	Sets the number of fully-closed encoder pulses for each motor rotation.				16384	Command unit	25 to 65535	Yes
Pn207	Position control setting 2	0	Selects position command filter.	0	Primary filter	0000	---	---	Yes
				1	Linear acceleration and deceleration				
		1	Speed command input switching (during position control)	0	Function not used.				
				1	REF used as feed-forward input.				
		2 to 3	Not used.	0	(Do not change setting.)				
Pn208	Position command filter time constant 2 (linear acceleration and deceleration)	Sets soft start for command pulse. (Soft start characteristics are for the linear acceleration and deceleration.)				0	x 0.01 ms	0 to 6400	---
Pn212 **	Not used.	(Do not change setting.)				2048	---	---	---
Pn217 **	Command pulse factor	Sets the factor used for position command pulse input.				1	Factor	1 to 99	---
Pn218 **	Position control setting 3	0	Command pulse factor switching selection	0	Function not used.	0000	---	---	Yes
				1	Rotates the Servomotor using the command pulse multiplied by the factor set in Pn217.				
		1 to 3	Not used.	0	(Do not change setting.)				

Note 1. Explanation for parameters set using 5 digits.

Note 2. Explanation for parameters requiring each digit No. to be set separately.

■ Speed Control Parameters (From Pn300)

Parameter No.	Parameter name	Explanation	Default setting	Unit	Setting range	Restart power?
Pn300	Speed command scale	Sets the REF (speed command input) voltage for operating at the rated rotation speed.	1000	0.01 V/No. of rated rotations	150 to 3000	---
Pn301	No. 1 internal speed setting	Number of rotations for No. 1 internal setting	100	r/min	0 to 10000	---
Pn302	No. 2 internal speed setting	Number of rotations for No. 2 internal setting	200	r/min	0 to 10000	---
Pn303	No. 3 internal speed setting	Number of rotations for No. 3 internal setting	300	r/min	0 to 10000	---
Pn304	Jog speed	Sets rotation speed during jog operation.	500	r/min	0 to 10000	---
Pn305	Soft start acceleration time	Sets acceleration time during speed control soft start.	0	ms	0 to 10000	---
Pn306	Soft start deceleration time	Sets deceleration time during speed control soft start.	0	ms	0 to 10000	---
Pn307	Speed command filter time constant	Sets constant during filter of speed command voltage input (REF).	40	x 0.01 ms	0 to 65535	---
Pn308	Speed feedback filter time constant	Sets constant during filter of speed feedback.	0	x 0.01 ms	0 to 65535	---
Pn309**	Not used.	(Do not change setting.)	60	---	---	---

■ Torque Control Parameters (From Pn400)

Parameter No.	Parameter name	Explanation (See note 1.)			Default setting	Unit	Setting range	Restart power?
		Digit No.	Name	Setting				
Pn400	Torque command scale				30	0.1 V/ rated torque	10 to 100	---
Pn401	Torque command filter time constant				40	x 0.01 ms	0 to 65535	---
Pn402	Forward torque limit				350	%	0 to 800	---
Pn403	Reverse torque limit				350	%	0 to 800	---
Pn404	Forward rotation external current limit				100	%	0 to 800	---
Pn405	Reverse rotation external current limit				100	%	0 to 800	---
Pn406	Emergency stop torque				350	%	0 to 800	---
Pn407	Speed limit				3000	r/min	0 to 10000	---

Parameter No.	Parameter name	Explanation (See note 1.)				Default setting	Unit	Setting range	Restart power?
		Digit No.	Name	Setting	Explanation (See note 2.)				
Pn408	Torque command setting	0	Selects notch filter 1 function.	0	Notch filter 1 not used.	0000	---	---	---
				1	Notch filter 1 used for torque commands.				
		1	Not used.	0	(Do not change setting.)				
		2	Selects notch filter 2 function.**	0	Notch filter 2 not used.				
				1	Notch filter 2 used for torque commands.				
3	Not used.	0	(Do not change setting.)						
Pn409	Notch filter 1 frequency	Sets notch filter 1 frequency for torque command.				2000	Hz	50 to 2000	---
Pn40A**	Notch filter 1 Q value	Sets Q value of notch filter 1.				70	x0.01	50 to 400	---
Pn40b**	Notch filter 2 frequency	Sets notch filter 2 frequency for torque command.				2000	Hz	50 to 2000	---
Pn40C**	Notch filter 2 Q value	Sets Q value of notch filter 2.				70	x0.01	50 to 400	---

Note 1. Explanation for parameters set using 5 digits.

Note 2. Explanation for parameters requiring each digit No. to be set separately.

■ Sequence Parameters (From Pn500)

Parameter No.	Parameter name	Explanation (See note 1.)				Default setting	Unit	Setting range	Restart power?
		Digit No.	Name	Setting	Explanation (See note 2.)				
Pn500	Positioning completion range 1	Sets the range of positioning completed output 1 (INP1).				3	Command unit	0 to 250	---
Pn501	Position lock rotation speed	Sets the number of rotations for position lock during speed control.				10	r/min	0 to 10000	---
Pn502	Rotation speed for motor rotation detection	Sets the number of rotations for the Servomotor rotation detection output (TGON).				20	r/min	0 to 10000	---
Pn503	Speed conformity signal output width	Sets the allowable fluctuation (number of rotations) for the speed conformity output (VCMP).				10	r/min	0 to 100	---
Pn504	Positioning completion range 2	Sets the range for positioning completed output 2 (INP2).				3	Command unit	1 to 250	---
Pn505	Deviation counter overflow level	Sets the detection level for the deviation counter over alarm.				1024	x 256 command unit	1 to 32767	---
Pn506	Brake timing 1	Sets the delay from the brake command to the Servomotor turning OFF.				0	x 10 ms	0 to 50	---
Pn507	Brake command speed	Sets the number of rotations for outputting the brake command.				100	r/min	0 to 10000	---
Pn508	Brake timing 2	Sets the delay time from the Servomotor turning OFF to the brake command output.				50	x 10 ms	10 to 100	---
Pn509	Momentary hold time	Sets the time during which alarm detection is disabled when a power failure occurs.				20	ms	20 to 1000	---

Parameter No.	Parameter name	Explanation (See note 1.)				Default setting	Unit	Setting range	Restart power?
		Digit No.	Name	Setting	Explanation (See note 2.)				
Pn50A	Input signal selection 1	0	Input signal allocation mode	0	Sets the sequence input signal allocation to the same as R88D-UT.	8100	---	---	Yes
				1	User-defined sequence input signal allocation				
		1	RUN signal (RUN command) input terminal allocation	0	Allocated to CN1, pin 40: Valid at low input.				
				1	Allocated to CN1, pin 41: Valid at low input				
				2	Allocated to CN1, pin 42: Valid at low input				
				3	Allocated to CN1, pin 43: Valid at low input				
				4	Allocated to CN1, pin 44: Valid at low input				
				5	Allocated to CN1, pin 45: Valid at low input				
				6	Allocated to CN1, pin 46: Valid at low input				
				7	Always enabled.				
				8	Always disabled.				
				9	Allocated to CN1, pin 40: Valid at high output				
				A	Allocated to CN1, pin 41: Valid at high output				
				b	Allocated to CN1, pin 42: Valid at high output				
				C	Allocated to CN1, pin 43: Valid at high output				
				d	Allocated to CN1, pin 44: Valid at high output				
E	Allocated to CN1, pin 45: Valid at high output								
F	Allocated to CN1, pin 46: Valid at high output								
2	MING signal input terminal allocation	0 to F	Same as Pn50A.1. MING (gain reduction) signal allocation						
3	POT signal input terminal allocation	0 to F	Same as Pn50A.1. POT (forward drive prohibited) signal allocation						
Pn50b	Input signal selection 2	0	NOT signal input terminal allocation	0 to F	Same as Pn50A.1. NOT (reverse drive prohibited) signal allocation	6548	---	---	Yes
		1	RESET signal input terminal allocation	0 to F	Same as Pn50A.1. RESET (alarm reset) signal allocation				
		2	PCL signal input terminal allocation	0 to F	Same as Pn50A.1. PCL (forward rotation current limit) signal allocation				
		3	NCL signal input terminal allocation	0 to F	Same as Pn50A.1. NCL (reverse rotation current limit) allocation				

Parameter No.	Parameter name	Explanation (See note 1.)				Default setting	Unit	Setting range	Restart power?
		Digit No.	Name	Setting	Explanation (See note 2.)				
Pn50C	Input signal selection 3	0	RDIR signal input terminal allocation	0 to F	Same as Pn50A.1. RDIR (rotation direction command) signal allocation	8888	---	---	Yes
		1	SPD1 signal input terminal allocation	0 to F	Same as Pn50A.1. SPD1 (speed selection reference 1) signal allocation				
		2	SPD2 signal input terminal allocation	0 to F	Same as Pn50A.1. SPD2 (speed selection command 2) signal allocation				
		3	TVSEL signal input terminal allocation	0 to F	Same as Pn50A.1. TVSEL (control mode switching) signal allocation				
Pn50d	Input signal selection 4	0	PLOCK signal input terminal allocation	0 to F	Same as Pn50A.1. PLOCK (position lock command) signal allocation	8888	---	---	Yes
		1	IPG signal input terminal allocation	0 to F	Same as Pn50A.1. IPG (pulse disable) signal allocation				
		2	GSEL signal input terminal allocation	0 to F	Same as Pn50A.1. GSEL (gain switching) signal allocation				
		3	Not used.	0	(Do not change setting.)				
Pn50E	Output signal selection 1	0	INP1 signal (positioning completed 1) output terminal allocation	0	No output	3211	---	---	Yes
				1	Allocated to CN1 pins 25, 26				
				2	Allocated to CN1 pins 27, 28				
				3	Allocated to CN1 pins 29, 30				
		1	VCMP signal output terminal allocation	0 to 3	Same as Pn50E.0. VCMP (speed coincidence) signal allocation				
		2	TGON signal output terminal allocation	0 to 3	Same as Pn50E.0. TGON (Servomotor rotation detection) signal allocation				
		3	READY signal output terminal allocation	0 to 3	Same as Pn50E.0. READY (Servomotor warmup complete) signal allocation				

Parameter No.	Parameter name	Explanation (See note 1.)				Default setting	Unit	Setting range	Restart power?
		Digit No.	Name	Setting	Explanation (See note 2.)				
Pn50F	Output signal selection 2	0	CLIMIT signal output terminal allocation	0 to 3	Same as Pn50E.0. CLIMIT (current limit detection) signal allocation	0000	---	---	Yes
		1	VLIMIT signal output terminal allocation	0 to 3	Same as Pn50E.0. VLIMIT (speed limit detection) signal allocation				
		2	BKIR signal output terminal allocation	0 to 3	Same as Pn50E.0. BKIR (brake interlock) signal allocation.				
		3	WARN signal output terminal allocation	0 to 3	Same as Pn50E.0. WARN (warning) signal allocation				
Pn510	Output signal selection 3	0	INP2 signal output terminal allocation	0 to 3	Same as Pn50E.0. INP2 (positioning completed 2) signal allocation	0000	---	---	Yes
		1	Not used.	0	(Do not change setting.)				
		2	PSON signal output terminal allocation**	0 to 3	Same as Pn50E.0. Command pulse factor enabled signal allocation				
		3	Not used.	0	(Do not change setting.)				
Pn511	Not used.	0 to 3	Not used.	8	(Do not change setting.)	8888	---	---	---
Pn512	Output signal reverse	0	Output signal reverse for CN1 pins 25, 26	0	Not reversed.	0000	---	---	Yes
				1	Reversed.				
		1	Output signal reverse for CN1 pins 27, 28	0	Not reversed.				
				1	Reversed.				
		2	Output signal reverse CN1 pins 29, 30	0	Not reversed.				
				1	Reversed.				
3	Not used.	0	(Do not change setting.)						
Pn513**	Input signal selection 6	0	PSEL signal input terminal allocation	0 to F	Same as Pn50A.1. Command pulse factor switching signal allocation	0088	---	---	Yes
		1	Not used.	8	(Do not change setting.)				
		2 to 3	Not used.	0	(Do not change setting.)				
Pn51A*	Motor-load deviation over level	Sets the allowable deviation level for fully-closed encoders and semi-closed encoders.				0	Command unit	0 to 32767	---
Pn51b**	Not used.	(Do not change setting.)				100	---	---	---

Parameter No.	Parameter name	Explanation (See note 1.)				Default setting	Unit	Setting range	Restart power?
		Digit No.	Name	Setting	Explanation (See note 2.)				
Pn51C**	Not used.	(Do not change setting.)				450	---	---	---
Pn51E**	Deviation counter overflow warning level	Sets the detection level for the deviation counter overflow warning. (Set as a percentage of the deviation counter overflow level (Pn505).)				0	%	0 to 100	---

Note 1. Explanation for parameters set using 5 digits.

Note 2. Explanation for parameters requiring each digit No. to be set separately.

■ Other Parameters (From Pn600)

Parameter No.	Parameter name	Explanation	Default setting	Unit	Setting range	Restart power?
Pn600	Regeneration resistor capacity	Setting for regeneration resistor load ratio monitoring calculations	0	x 10 W	From 0 (varies by Unit.)	---
Pn601	Not used.	(Do not change setting.)	0	---	---	---

6-5 Alarms and Warnings when a JUSP-NS115 MECHATROLINK-II Option Unit is Mounted

When a Yaskawa JUSP-NS115 MECHATROLINK-II Option Unit (OMRON model number: FNY-NS115) is mounted to the Servo Driver, the following Option Board alarms and warnings are added to those listed in *5-2 Alarms*.

■ Alarms

Display	Alarm code			Error detected	Cause of error and countermeasures
	AL01	AL02	AL03		
A.b6	OFF	OFF	OFF	Gate array error	An error was detected at the communications LSI. <ul style="list-style-type: none"> • If the error occurs after powering up again, replace the Option Board.
A.C6	ON	OFF	ON	Full closed-loop phase A or B open	An error was detected in the Full Closed-loop Encoder phase A or B. <ul style="list-style-type: none"> • Check for faulty Encoder wiring or faulty contact. • The Encoder may be affected by noise. Implement measures against noise, such as separating the Encoder wiring from the main-circuit power supply lines. • The Encoder may be defective. Replace the Encoder. • The Servo Driver may be defective. Replace the Servo Driver.
A.C7	ON	OFF	ON	Full closed-loop phase C open	An error was detected in the Full Closed-loop Encoder phase C. <ul style="list-style-type: none"> • Implement the same countermeasures as for A.C6.
A.E0	OFF	ON	ON	No option or local address setting	The Option Board is not mounted correctly. <ul style="list-style-type: none"> • Mount the Option Board correctly. The local address is not set correctly. <ul style="list-style-type: none"> • The local address setting error occurs when the local address setting switch SW0 is set to 0 and the local address setting switch SW2 is set to OFF.
A.E1	OFF	ON	ON	Option timeout	There is no response from the Option Board. <ul style="list-style-type: none"> • Turn OFF the power and remove and reinsert the Option Board. Then try the operation again. • If the problem still occurs, replace the Option Board.

Display	Alarm code			Error detected	Cause of error and countermeasures
	AL01	AL02	AL03		
A.E2	OFF	ON	ON	Option WDC error	<p>Communications with the host controller were interrupted.</p> <ul style="list-style-type: none"> • Turn the power OFF and back ON again for both the host controller and the Servo Driver. If the problem still occurs, take the following measures. • The host controller may be defective. Replace the host controller. • The Option Board may be defective. Replace the Option Board.
A.E5	OFF	ON	ON	WDT error	<p>MECHATROLINK-II is not being synchronized.</p> <ul style="list-style-type: none"> • There may be effects from noise. Implement measures against noise, such as separating the communications lines from the main-circuit power supply lines.
A.E6	OFF	ON	ON	Communications error	<p>A MECHATROLINK-II communications error occurred two consecutive times.</p> <ul style="list-style-type: none"> • Check whether the Communications Cable (the cable and connector) is making proper contact. • The Encoder may be affected by noise. Implement measures against noise, such as separating the Encoder wiring from the main-circuit power supply lines.
A.EA	OFF	ON	ON	Servo Driver failure	<p>A Servo Driver error was detected.</p> <ul style="list-style-type: none"> • If the error occurs after powering up again, replace the Servo Driver.
A.EB	OFF	ON	ON	Servo Driver initial access error	<p>A Servo Driver error was detected.</p> <ul style="list-style-type: none"> • If the error occurs after powering up again, replace the Servo Driver.
A.EC	OFF	ON	ON	Servo Driver WDC error	<p>A Servo Driver error was detected.</p> <ul style="list-style-type: none"> • If the error occurs after powering up again, replace the Servo Driver.
A.ED	OFF	ON	ON	Command not executed	<p>A MECHATROLINK-II command was aborted.</p> <ul style="list-style-type: none"> • The command may have been aborted by an operation from the Support Software (WMON). Execute the command again after the Support Software operation has been completed.

■ Warnings

Display	Alarm code			Error detection function	Cause of error and countermeasures
	AL01	AL02	AL03		
A.94	ON	ON	OFF	Data setting warning	<p>A value was set out of range using MECHATROLINK-II communications.</p> <ul style="list-style-type: none"> • Check whether a data address or the data specified by the host controller (with the host Support Software) was set out of range. • If connected to an MCH Unit, the Option Monitor (Servo Driver parameter) may not be set correctly. Check whether Pn813 is set to 0032 (hex) and, if not, set it to 0032.
A.95	OFF	ON	OFF	Command warning	<p>Preparations were not ready to execute a command received by MECHATROLINK-II communications, and therefore the command was not executed.</p> <ul style="list-style-type: none"> • This warning occurs in the following cases. Discontinue the operation that caused the warning, and try again. <ul style="list-style-type: none"> • An attempt was made to execute a servo lock while the Servo Driver's main circuit was OFF. • Host controller (including the host Support Software) or Servo Driver parameters were read or written while communications with WMON were in progress. • The same node number is set twice.
A.96	ON	OFF	OFF	Communications warning	<p>A communications error was detected. If it occurs two consecutive times, an A.E6 communications error will occur.</p> <ul style="list-style-type: none"> • The same node number is set twice. Correct the node numbers, and then execute the communications again. • The communications may be affected by noise from peripheral devices, or by vibration or shock. Implement measures against noise, such as separating the communications cable from the main-circuit power supply lines.

Index

Numbers

90° phase difference pulse, 2-78

A

A/B, 2-78

A/B/Z, 2-86

ABS, 2-86

absolute encoder

 Absolute Encoder Backup Battery Unit, 2-182

 battery replacement, 5-23

 setup, 4-6

absolute encoder multi-turn setting (Pn205), 4-60

absolute encoder output, 2-86

AC Servo Drivers. *See* Servo Drivers

AC Servomotors. *See* Servomotors

AC/DC power supply input selection (Pn001.2), 4-44

adhesive friction compensation function selection (Pn110.2), 4-56

adjustment function, 4-101

alarm history data clear (Fn006), 4-132

alarm history display (Fn000), 4-131

alarm reset, 2-82

alarm reset input terminal allocation (Pn50b.1), 4-39

alarm stop selection (Pn001.0), 4-33

alarm table, 5-5

ALM, 2-87

ALO1, ALO2, ALO3, 2-87

AM allocation (Pn003.0), 4-47

analog monitor allocation (Pn003), 4-47

analog monitor cable, 2-152

analog monitor output, 4-128

analog monitor output offset manual adjustment (Fn00C), 4-142

analog monitor output scaling (Fn00d), 4-144

applicable standards, 1-10

B

backup battery input, 2-81

BAT, 2-81

battery

 connector specifications, 2-91

 replacing, 5-23

bias addition band (Pn108), 4-51

bias function, 4-109

bias rotational speed (Pn107), 4-51

bit display, 4-121

BKIR, 2-89

BKIR signal output terminal allocation (Pn50F.2), 4-42

brake command speed (Pn507), 4-70

brake interlock, 4-88

brake interlock output, 2-89

brake interlock output terminal allocation (Pn50F.2), 4-42

brake timing 1 (Pn506), 4-69

brake timing 2 (Pn508), 4-70

C

cables

 connecting to computer, 2-152

 Servo Relay Units, 2-159

 specifications, 2-120

changing absolute encoder multi-turn setting (Fn013), 4-153

charge indicator, 4-121

CLIMT, 2-88

CLIMT signal output terminal allocation (Pn50F.0), 4-42

CN1 specifications, 2-68

CN2 specifications, 2-89

CN3 specifications, 2-90

CN5 specifications, 2-90

CN8 specifications, 2-91

command offset adjustment (Fn009, 00A, 00b), 4-138

command pulse mode selection (Pn200.0), 4-35

connecting cables, 3-9

connection examples, 6-2

Connector Terminal Block Cables, 2-124

connectors

 conformance to EC Directives, 3-5

 specifications, 2-120

contactors, 3-25, 3-35

control cables, specifications, 2-120

control I/O

 connector, 2-154

 signals, 2-70

 specifications, 2-68

control input

 circuits, 2-74

 details, 2-77

control mode selection (Pn000.1), 4-33

control mode switch, 2-83

control mode switching input terminal allocation (Pn50C.3), 4-40

control output

- circuits, 2-76
- details, 2-86
- sequence, 2-86

countermeasures, 5-2

current limit detection output, 2-88

current limit detection output terminal allocation (Pn50F.0), 4-42

CW/CCW, 2-78

D

DC Reactors, 2-184

deviation counter overflow level (Pn505), 4-69

deviation counter reset, 2-81

deviation counter reset (Pn200.1), 4-58

deviation counter reset when servo is OFF and an alarm occurs (Pn200.2), 4-58

diagnostic functions, 2-65

dimensions

- Parameter Units, 2-32
- Servo Drivers, 2-24
- Servomotors, 2-33
- Servomotors with gears, 2-49

displays, 4-120

drive prohibit, 4-85

dynamic brake, 4-34

E

ECRST, 2-81

electron thermal characteristics, 5-20

electronic gear function, 4-94

electronic gear ratio (Pn202, 203), 4-59

emergency stop torque, 4-66

encoder

- cable, 2-133
- dividing function, 4-87
- input specifications, 2-89
- outputs, 2-86
- specifications, 2-119

encoder dividing rate (Pn201), 4-59

external current limits (Pn404, 405), 4-66

External Regeneration Resistors/Resistance Units, 2-180, 3-41

I-2

F

feed pulse, 2-78

feed-forward amount (Pn109), 4-52

feed-forward command filter (Pn10A), 4-52

feed-forward function, 4-110

Fn□□□ (System Check Mode), 4-130

forward drive prohibit, 2-82, 4-85

forward drive prohibit input terminal allocation (Pn50A.3), 4-39

forward pulse, 2-78

forward rotation current limit, 2-82

forward rotation current limit input terminal allocation (Pn50b.2), 4-40

forward rotation external current limit (Pn404), 4-66

forward torque limit (Pn402), 4-65

fully-closed encoder pulses (Pn206), 4-60

fully-closed encoder usage method (Pn002.3), 4-46

G

G1, G2, 4-59

gain adjustment, 4-101

gain change input, 2-85

gain reduction, 4-90

gain reduction input, 2-81

gain reduction input terminal allocation (Pn50A.2), 4-39

gain switching, 4-113

gain switching input terminal allocation, 4-41

General Control Cables, 2-123

GSEL, 2-85

GSEL signal input terminal allocation (Pn50d.2), 4-41

H-L

harmonic current countermeasures, 3-27

I/O signal allocation (Pn50A to Pn512), 4-36

inertia ratio (Pn103), 4-50

INP1 signal output terminal allocation (Pn50E.0), 4-41

INP1, INP2, 2-87

INP2 signal output terminal allocation (Pn510.0), 4-42

input signal allocation mode (Pn50A.0), 4-38

internal speed settings (Pn301, 302, 303), 4-63

internally-set speed control, 4-77

IPG, 2-85

IPG signal input terminal allocation (Pn50d.1), 4-41

jog operation, 4-12

jog speed (Pn304), 4-64
leakage breakers, 3-26, 3-36

M

manual tuning, 4-104
MING, 2-81
MING signal input terminal allocation (Pn50A.2), 4-39
mode changes and display contents, 4-10
modes, 4-9
momentary hold time, 4-70
Monitor Mode, 4-123
monitor output, 4-127
monitor output connector, specifications, 2-90
Motion Control Unit Cables, 2-120
motor rotation detection output, 2-88
motor-load deviation over level, 4-71

N

NCL, 2-82
NCL signal input terminal allocation (Pn50b.3), 4-40
NFB, 3-23, 3-32
NM allocation (Pn003.1), 4-47
No. 1 internal speed setting (Pn301), 4-63
No. 2 internal speed setting (Pn302), 4-64
No. 2 position loop gain (Pn106), 4-50
No. 2 speed loop gain (Pn104), 4-50
No. 2 speed loop integral time constant (Pn105), 4-50
No. 3 internal speed setting (Pn303), 4-64
no-fuse breakers, 3-23, 3-32
noise filters, 3-24, 3-33
nomenclature, 1-9
NOT, 2-82
NOT signal input terminal allocation (Pn50b.0), 4-39
notch filter, 4-115
notch filter function selection (Pn408.0), 4-66

O

online auto-tuning, 4-101
online auto-tuning selection (Pn110.0), 4-55
online auto-tuning setting (Pn110), 4-54
operation details, 4-8
operation switching using an absolute encoder (Pn002.2), 4-46

operational procedure, 4-3
Option Unit detection results clear (Fn014), 4-154
output signal reverse (Pn512), 4-43
overload characteristics, 5-20
overtravel stop selection (Pn001.1), 4-34

P

P control switching, 4-118
 acceleration command (Pn10E), 4-54
 conditions, 4-52
 deviation pulse (Pn10F), 4-54
 speed command (Pn10d), 4-54
 torque command (Pn10C), 4-53
Parameter Unit
 cable, 2-178
 dimensions, 2-32
 input specifications, 2-90
 specifications, 2-177
parameters
 checking, 4-150
 details, 4-43
 important parameters, 4-32
 initializing (Fn005), 4-137
 parameter tables, 4-18
 setting and checking, 4-16
password setting (Fn010), 4-149
PCL, 2-82
PCL signal input terminal allocation (Pn50b.2), 4-40
periodic maintenance, 5-21
peripheral device connection examples, 3-15
pins CN1-25 and 26 output signal reverse (Pn512.0), 4-43
pins CN1-27 and 28 output signal reverse (Pn512.0), 4-43
pins CN1-29 and 30 output signal reverse (Pn512.0), 4-43
PLOCK, 2-84
PLOCK signal input terminal allocation (Pn50d.0), 4-41
position command filter function, 4-95
position command filter selection (Pn207.0), 4-61
position command filter time constant 1 (Pn204), 4-59
position command filter time constant 2 (Pn208), 4-62
position completion range 1, 4-68
position control, 4-73
position lock command input, 2-84
position lock command input terminal allocation (Pn50d.0), 4-41
position lock function, 4-97
position lock rotation speed (Pn501), 4-68
position loop block diagram, 4-108
position loop gain (Pn102), 4-49
positioning completed output 1 terminal allocation (Pn50E.0), 4-41

positioning completed output 2 terminal allocation (Pn510.0), 4-42

positioning completion range 2, 4-69

POT, 2-82

POT signal input terminal allocation (Pn50A.3), 4-39

power cable, 2-134

power supply indicator, 4-121

preparing for operation, 4-4

protective functions, 2-65

PULS, 2-78

pulse command filter selection (Pn200.3), 4-58

pulse disable input, 2-85

pulse disable input terminal allocation (Pn50d.1), 4-41

R

RDIR, 2-83

RDIR signal input terminal allocation (Pn50C.0), 4-40

Reactor, 3-27

READY, 2-88

READY signal output terminal allocation (Pn50E.3), 4-42

REF, 2-77

regeneration resistor capacity (Pn600), 4-72

regenerative energy, 3-38

- absorption by external regeneration resistance, 3-41
- absorption capacity, 3-40

RESET, 2-82

RESET signal input terminal allocation (Pn50b.1), 4-39

reverse drive prohibit, 2-82, 4-85

reverse drive prohibited input terminal allocation (Pn50b.0), 4-39

reverse pulse, 2-78

reverse rotation current limit, 2-82

reverse rotation current limit input terminal allocation (Pn50b.3), 4-40

reverse rotation external current limit (Pn405), 4-66

reverse rotation mode (Pn000.0), 4-32

reverse torque control (Pn403), 4-66

rigidity setting during online auto-tuning (Fn001), 4-133

rotation direction command input, 2-83

rotation direction command input terminal allocation (Pn50C.0), 4-40

rotation speed for motor rotation detection (Pn502), 4-69

RUN, 2-81

RUN signal input terminal allocation, 4-38

S

SEN, 2-81

sensor ON input, 2-81

Servo Drivers

- combining with Servomotors, 2-22
- dimensions, 2-24
- installation conditions, 3-3
- performance specifications, 2-63
- regenerative energy absorption capacity, 3-40
- replacing, 5-3
- specifications, 2-62

Servo ready output, 2-88

Servo Relay Units, 2-156

Servomotor current detection offset adjustment (Fn00E, 00F), 4-145

Servomotor origin search (Fn003), 4-135

Servomotor ready output terminal allocation (Pn50E.3), 4-42

Servomotor rotation detection output terminal allocation (Pn50E.2), 4-42

Servomotors

- checking parameters, 4-150
- combining with Servo Drivers, 2-22
- dimensions, 2-33
- general specifications, 2-93
- operating environment, 3-4
- performance specifications, 2-95
- replacing, 5-3

Servomotors with gears

- combinations, 2-13
- dimensions, 2-49
- specifications, 2-114
- standard models, 2-16

SIGN, 2-78

soft start acceleration time (Pn305), 4-64

soft start deceleration time (Pn306), 4-64

soft start function, 4-93

SPD1 signal input terminal allocation (Pn50C.1), 4-40

SPD1, SPD2, 2-83

SPD2 signal input terminal allocation (Pn50C.2), 4-40

specifications

- battery connector, 2-91
- cables, 2-120
 - CN1, 2-68
 - CN2, 2-89
 - CN3, 2-90
 - CN5, 2-90
 - CN8, 2-91
- connectors, 2-120
- control cables, 2-120
- control I/O, 2-68
- encoder, 2-119
- monitor output connector, 2-90
- Parameter Unit, 2-177
- Parameter Unit input, 2-90
- Servo Drivers, 2-62

- Servomotors, 2-93
- Servomotors with gears, 2-114
- terminal block, 2-67
- speed and torque command offset manual adjustment (Fn009), 4-138
- speed command filter time constant (Pn307), 4-64
- speed command input, 2-77
- speed command input switching for position control (Pn207.1), 4-61
- speed command input switching for torque control (Pn002.1), 4-46
- speed command offset manual adjustment (Fn00A), 4-139
- speed command scale (Pn300), 4-63
- speed conformity output, 2-87
- speed conformity output terminal allocation (Pn50E.1), 4-42
- speed conformity signal output width (Pn503), 4-69
- speed control, 4-74
- speed control loop switching (Pn10b.1), 4-53
- speed feedback compensating gain (Pn111), 4-56
- speed feedback compensation, 4-117
- speed feedback compensation function selection (Pn110.1), 4-55
- speed feedback filter, 4-118
- speed feedback filter time constant (Pn308), 4-64
- speed feed-forward function, 4-112
- speed limit (Pn407), 4-66
- speed limit detection output, 2-88
- speed limit detection output terminal allocation (Pn50F.1), 4-42
- speed limit function, 4-98
- speed loop gain (Pn100), 4-48
- speed loop integration constant (Pn101), 4-49
- speed selection command 1 input terminal allocation (Pn50C.1), 4-40
- speed selection command 2 input terminal allocation (Pn50C.2), 4-40
- speed selection commands, 2-83
- standard models, 2-2
- Status Display Mode, 4-121
- storing online auto-tuning results (Fn007), 4-134
- surge absorbers, 3-23, 3-32
- surge killers, 3-25, 3-35
- switching control, 4-82
- symbol display, 4-121
- system block diagrams, 1-11

- System Check Mode, 4-130
- system configuration, 1-7

T

- terminal block
 - specifications, 2-67
 - wiring, 3-17
- TGON signal output terminal allocation (Pn50E.2), 4-42
- torque command filter time constant (Pn401), 4-65
- torque command input, 2-77
- torque command input change (Pn002.0), 4-45
- torque command offset manual adjustment (Fn00b), 4-141
- torque command scale (Pn400), 4-65
- torque control, 4-76
- torque feed-forward function, 4-110
- torque limit function, 4-91
- torque limits (Pn402, 403), 4-65
- TREF, 2-77
- trial operation procedure, 4-99
- troubleshooting, 5-9
 - countermeasures, 5-2
 - using the operating status, 5-18
- TVSEL, 2-83
- TVSEL signal input terminal allocation (Pn50C.3), 4-40

U–W

- unit number setting (Pn000.2), 4-44
- Un□□□ (monitor mode), 4-123
- VCMP, 2-87
- VCMP signal output terminal allocation (Pn50E.1), 4-42
- version check (Fn012), 4-152
- VLIMIT, 2-88
- VLIMIT signal output terminal allocation (Pn50F.1), 4-42
- WARN, 2-89
- WARN signal output terminal allocation (Pn50F.3), 4-42
- warning code output selection (Pn001.3), 4-45
- warning output, 2-89
- warning output terminal allocation (Pn50F.3), 4-42
- wiring
 - conformance to EMC Directives, 3-28
 - noise resistance, 3-21

Revision History

A manual revision code appears as a suffix to the catalog number on the front cover of the manual.

Cat. No. I531-E1-08

The following table outlines the changes made to the manual during each revision. Page numbers refer to the previous version.

Revision code	Date	Revised content
01	March 2000	Original production
02	March 2002	<p>Pages 1-5, 1-6, 1-7, 2-2, 4-139: Information on DeviceNet Option Unit added.</p> <p>Pages 1-6, 2-52, 2-130, 3-6, 3-15, 3-29, 5-20: Changes made in several places.</p> <p>Pages 2-2, 2-3, 2-26, 2-27, 2-32, 2-33, 2-70, 2-96, 2-128, 3-7, 3-9, 3-21, 3-28, 3-30, 4-9, 4-20, 4-24, 4-29, 4-55, 4-87, 4-111, 4-117, 4-139, 4-142, 5-5, 5-6, 5-7, 5-10, 5-12, 5-14, 5-20, 6-9, 6-14, 6-19: Changes and additions made to tables.</p> <p>Page 2-8: Change made to information before second table.</p> <p>Pages 2-26, 2-27, 2-28, 2-29, 2-32, 2-33, 2-34, 2-35, 2-54, 2-55, 2-106, 2-108, 2-116, 2-120, 2-123, 2-125, 2-128, 2-129, 3-8, 3-37, 4-10: Changes and additions made to diagrams.</p> <p>Page 2-49: Minor changes made to humidity and insulation resistance specifications.</p> <p>Pages 2-52, 2-69, 2-70, 2-72, 2-94, 2-95, 2-96, 2-110, 2-112, 3-12, 3-13, 4-18, 4-40, 5-8, 6-8: Notes changed and added.</p> <p>Page 2-70: Change made to information before table.</p> <p>Pages 2-78, 2-80, 2-85, 2-89: Information on induced voltage constant, winding resistance, and winding impedance removed from tables.</p> <p>Page 2-107: Company name changed in several places.</p> <p>Pages 2-108, 2-109: Information on cables and servomotors changed in several places.</p> <p>Page 2-117: Information on Encoder Connectors added.</p> <p>Page 2-120: Information on Servo Relay Unit added.</p> <p>Page 2-121: Information on XW2Z-□J-A2 removed.</p> <p>Pages 2-122, 2-124: Changes made to information before bottom table.</p> <p>Page 2-125: Information on Position Control Unit Cables added.</p> <p>Page 3-20: Change made to information before first table.</p> <p>Page 4-30: Information added before first table and after last table.</p> <p>Page 4-40: Information added after second table.</p> <p>Pages 4-42, 4-54: Changes made to first table and note.</p> <p>Page 4-62: Information added after third table.</p> <p>Page 4-109: Information added after bottom table.</p> <p>Page 4-135: Information removed from second paragraph.</p> <p>Page 4-139: Function code changed in 3 places.</p> <p>Page 5-5: Minor changes made to Note 3.</p> <p>Pages 6-2 to 6-6: Connection examples added and existing examples changed in several places.</p>

Revision History

Revision code	Date	Revised content
03	March 2003	<p>Page 1-2, 1-7, 1-8: Features and standards of new W-series models added.</p> <p>Page 2-3: Information added after table.</p> <p>Page 2-6: Information added after table.</p> <p>Page 2-13: Information added for 1,500-r/min Servomotors.</p> <p>Page 2-64, 2-65: New functions added for software version "r.0037."</p> <p>Page 2-67, 2-69, 2-75: Information on automatic reset fuse added.</p> <p>Page 2-70, 2-71: New control I/O signals added to table.</p> <p>Page 2-82: Information added and changed in section on speed selection commands and control mode switch.</p> <p>Page 2-84: Information added on command pulse factor switching input.</p> <p>Page 2-88: Information added on command pulse factor enabled output. Information on automatic reset fuse added to table.</p> <p>Page 2-92: Information added for 1,500-r/min Servomotors.</p> <p>Page 2-110: Caution changed to include new Servomotor models.</p> <p>Page 2-133: Information added for 1,500-r/min Servomotors.</p> <p>Page 2-134 : Information on peripheral cables added.</p> <p>Page 2-164, 2-165: Information added to include new Servo Driver models.</p> <p>Page 3-7, 3-9: Information changed to include new Servomotor and Servo Driver models.</p> <p>Page 3-11, 3-12: Information added to table for 1,500-r/min Servomotors.</p> <p>Page 3-16: Information added to include new Servo Driver models.</p> <p>Page 3-19: Information added for power cable for 1,500-r/min Servomotors.</p> <p>Page 3-25: Information added to include new Servo Driver models.</p> <p>Page 3-27: Information on EMC directives changed.</p> <p>Page 3-40, 3-41, 3-43: Information added to include new Servo Driver models.</p> <p>Page 4-21, 4-23, 4-25, 4-27, 4-31, 4-32, 4-40, 4-41, 4-42, : Information on new functions and parameters added for software version "r.0037."</p> <p>Page 4-49: Information added for gain switching.</p> <p>Page 4-52, 4-56, 4-57: Information added for automatic gain switching function.</p> <p>Page 4-61: Information added for software version "r.0037."</p> <p>Page 4-62: Information added for command pulse factor and position control setting 3.</p> <p>Page 4-66, 4-67, 4-68: Information on additional notch filter functions added.</p> <p>Page 4-71: Information added for new parameter for software version "r.0037."</p> <p>Page 4-74, 4-75, 4-77, 4-78: Minor changes.</p> <p>Page 4-79, 4-83: Notes added after table.</p> <p>Page 4-95: Information added for software version "r.0037."</p> <p>Page 4-101 : Information added for automatic gain switching.</p> <p>Page 4-114, 4-115, 4-116 : Information added for automatic gain switching.</p> <p>Page 4-116, 4-117: Information for new notch filter functions added.</p> <p>Page 4-129: Information added to include new Servo Driver models.</p> <p>Page 5-7: Information added for new functions for software version "r.0037."</p> <p>Page 5-9, 5-16, 5-17: Troubleshooting information added for new functions for software version "r.0037."</p> <p>Page 5-23: Information added to include new Servo Driver models.</p> <p>Page 6-12: Information added for single-phase power supply used with 3,000-r/min Servomotors.</p> <p>Page 6-16, 6-17, 6-19, 6-21, 6-24, 6-25: Information added for new parameters for software version "r.0037."</p>

Revision History

Revision code	Date	Revised content
04	May 2005	<p>The abbreviation for Programmable Controller changed from PC to PLC throughout the manual.</p> <p>General Warnings: Last caution changed.</p> <p>Precautions: "regenerative resistors" changed to "regeneration resistors."</p> <p>Page 1-5: Note at bottom of page altered.</p> <p>Page 1-6: Additions to graphic and text at bottom of page altered.</p> <p>Pages 2-5, 2-130, and 3-14: Note altered.</p> <p>Page 2-46: Dimension KB2 corrected from 316 to 317.</p> <p>Pages 2-48, 2-49, 2-52, and 2-53: Table altered and graphics replaced/added.</p> <p>Pages 2-58 and 2-59: Dimension LM corrected from 110 to 97.5.</p> <p>Pages 2-64, 5-5, and 5-8: Note added.</p> <p>Page 2-67 and 2-68: Graphics corrected.</p> <p>Page 2-75: Bottom graphic corrected.</p> <p>Page 2-87: Information added to READY/READYCOM description.</p> <p>Pages 2-95, 2-96, 2-101, 2-105, and 2-109: Brake specifications corrected.</p> <p>Pages 2-112 and 2-113: Specifications corrected in table.</p> <p>Page 2-116: Reduction gear inertias and weights corrected in tables for 750-W models.</p> <p>Page 2-132: Addition made to note.</p> <p>Page 3-6: "B" added to two model numbers.</p> <p>Page 3-11: "A" added to model number in note.</p> <p>Page 3-18: Wago Lever model changed.</p> <p>Page 3-20: Information added at top of page.</p> <p>Page 3-21: Top table replaced. Table removed.</p> <p>Page 3-23: Bottom table replaced.</p> <p>Page 3-26: Sentence deleted from first paragraph.</p> <p>Page 3-31: Leakage currents corrected in table.</p> <p>Page 3-36: "Eg3" added at bottom of page.</p> <p>Page 4-32: Notes deleted and "Pn" added to heading.</p> <p>Page 4-40: "Position control" added for Pn513.0.</p> <p>Page 4-49: Parameter corrected in first item under Pn103 and section number reference corrected in second item.</p> <p>Page 4-59: Paragraph added before note at end of Pn205.</p> <p>Page 4-60: Second item at top of page altered and end of note at top of page corrected.</p> <p>Page 4-124: "All output mode" corrected for Un001.</p> <p>Page 4-125: Note altered at bottom of page.</p> <p>Page 4-135: "Option detection error" changed to "option error" and text added under <i>Not Using an Option Unit</i>.</p> <p>Page 4-140: Items at top of page altered.</p> <p>Page 5-2: Information added to <i>Selecting Analysis Tools</i>.</p> <p>Page 5-15: Countermeasure added for A.E7.</p> <p>Page 6-10: Examples added.</p> <p>Page 6-12: Information added at bottom of page.</p> <p>Page 6-14: Description of a setting of 1 for digit 0 of Pn001 changed.</p> <p>Page 6-15: Description of a setting of 2 for digit 0 of Pn003 changed.</p> <p>Pages 6-15 to 6-25: Notes and references to them removed.</p> <p>Page 6-18: Name of Pn201 changed.</p> <p>Page 6-19: Description of Pn300 changed.</p>

Revision History

Revision code	Date	Revised content
05	December 2005	<p>“CS1” was globally changed to “CS” for the PLC Series designation and “Series” added. “(-V1)” was added for the CS1W-MC221/421.</p> <p>Inside Front Cover: Precautions added.</p> <p>“Notice” Page: Sentence added to signal word definitions.</p> <p>Pages 2-46 and 2-47: Output section dimensions added.</p> <p>Pages 2-71, 2-88, 4-31, 4-41, 5-5, and 5-7: Overline removed from ‘WARN’ and ‘OFF’ changed to ‘ON.’</p> <p>Pages 4-19 and 6-15: “Negative” changed to “positive” for digit 0 of PN000.</p> <p>Pages 4-29 and 6-24: “For low output” changed to “at low input.”</p> <p>Page 4-41: Second bulleted paragraph removed.</p> <p>Pages 5-5 and 6-27: Added information on alarms and warnings when a JUSP-NS115 Option Unit is mounted.</p> <p>Page 5-7: Second note removed.</p>
06	June 2007	<p>Under Warning Labels at front of manual: Precautionary information about battery disposal added.</p> <p>After Table of Contents: Warranty and liability information added.</p> <p>Pages 2-6 and 3-12: Information on Robot Cables added.</p> <p>Pages 2-36 and 2-37: Models added to heading.</p> <p>Page 2-89: Cable plug model number corrected at top of page.</p> <p>Page 2-92: Row for protective structure removed, note 2 deleted, and section added on degree of protection.</p> <p>Pages 2-93, 2-94, 2-95, 2-100, 2-101, 2-104, 2-105, 2-108, and 2-109: Entries for applicable load inertia and note 6 changed.</p> <p>Page 2-123: Section added on Cables and Connector Terminal Blocks.</p> <p>Page 2-124: Section added on motor cable specifications and heading changed.</p> <p>Page 2-125: Socket/plug model numbers corrected (three locations) and number removed from heading.</p> <p>Page 2-135: Terminal indication for Servomotor added and information on Robot Cables added.</p> <p>Pages 2-137 and 2-138: Plug model number corrected at bottom of page.</p> <p>Page 2-165: Section on manufacturing codes added.</p> <p>Page 3-9: Item “7” added to graphic, other number corrected accordingly, and note added.</p> <p>Page 3-24: Table replaced.</p> <p>Page 3-31: Next to last sentence removed in first paragraph of Surge Absorbers.</p> <p>Page 3-40: “Regeneration processing circuit” changed to “regeneration resistor.”</p> <p>Page 3-43: Section added.</p> <p>Page 4-34: Section added on dynamic brake.</p> <p>Page 4-65: Third note on page changed.</p> <p>Page 4-68: Sentence add toward bottom of page.</p> <p>Pages 6-2 to 6-13 : Power Cable and Encoder Cable model numbers added.</p> <p>Page 6-28 : Lines for A.C7 and A.E0 changed.</p> <p>Page 6-30 : Item added for A.94.</p>
07	February 2008	<p>Page 2-184: Corrected lines in dimensions diagram.</p> <p>Pages 3-35 and 3-36: Replaced section on leakage breakers.</p>
08	March 2009	Corrected mistakes.

Terms and Conditions of Sale

- Offer; Acceptance.** These terms and conditions (these "Terms") are deemed part of all quotes, agreements, purchase orders, acknowledgments, price lists, catalogs, manuals, brochures and other documents, whether electronic or in writing, relating to the sale of products or services (collectively, the "Products") by Omron Electronics LLC and its subsidiary companies ("Omron"). Omron objects to any terms or conditions proposed in Buyer's purchase order or other documents which are inconsistent with, or in addition to, these Terms.
- Prices; Payment Terms.** All prices stated are current, subject to change without notice by Omron. Omron reserves the right to increase or decrease prices on any unshipped portions of outstanding orders. Payments for Products are due net 30 days unless otherwise stated in the invoice.
- Discounts.** Cash discounts, if any, will apply only on the net amount of invoices sent to Buyer after deducting transportation charges, taxes and duties, and will be allowed only if (i) the invoice is paid according to Omron's payment terms and (ii) Buyer has no past due amounts.
- Interest.** Omron, at its option, may charge Buyer 1-1/2% interest per month or the maximum legal rate, whichever is less, on any balance not paid within the stated terms.
- Orders.** Omron will accept no order less than \$200 net billing.
- Governmental Approvals.** Buyer shall be responsible for, and shall bear all costs involved in, obtaining any government approvals required for the importation or sale of the Products.
- Taxes.** All taxes, duties and other governmental charges (other than general real property and income taxes), including any interest or penalties thereon, imposed directly or indirectly on Omron or required to be collected directly or indirectly by Omron for the manufacture, production, sale, delivery, importation, consumption or use of the Products sold hereunder (including customs duties and sales, excise, use, turnover and license taxes) shall be charged to and remitted by Buyer to Omron.
- Financial.** If the financial position of Buyer at any time becomes unsatisfactory to Omron, Omron reserves the right to stop shipments or require satisfactory security or payment in advance. If Buyer fails to make payment or otherwise comply with these Terms or any related agreement, Omron may (without liability and in addition to other remedies) cancel any unshipped portion of Products sold hereunder and stop any Products in transit until Buyer pays all amounts, including amounts payable hereunder, whether or not then due, which are owing to it by Buyer. Buyer shall in any event remain liable for all unpaid accounts.
- Cancellation; Etc.** Orders are not subject to rescheduling or cancellation unless Buyer indemnifies Omron against all related costs or expenses.
- Force Majeure.** Omron shall not be liable for any delay or failure in delivery resulting from causes beyond its control, including earthquakes, fires, floods, strikes or other labor disputes, shortage of labor or materials, accidents to machinery, acts of sabotage, riots, delay in or lack of transportation or the requirements of any government authority.
- Shipping; Delivery.** Unless otherwise expressly agreed in writing by Omron:
 - Shipments shall be by a carrier selected by Omron; Omron will not drop ship except in "break down" situations.
 - Such carrier shall act as the agent of Buyer and delivery to such carrier shall constitute delivery to Buyer;
 - All sales and shipments of Products shall be FOB shipping point (unless otherwise stated in writing by Omron), at which point title and risk of loss shall pass from Omron to Buyer; provided that Omron shall retain a security interest in the Products until the full purchase price is paid;
 - Delivery and shipping dates are estimates only; and
 - Omron will package Products as it deems proper for protection against normal handling and extra charges apply to special conditions.
- Claims.** Any claim by Buyer against Omron for shortage or damage to the Products occurring before delivery to the carrier must be presented in writing to Omron within 30 days of receipt of shipment and include the original transportation bill signed by the carrier noting that the carrier received the Products from Omron in the condition claimed.
- Warranties.** (a) **Exclusive Warranty.** Omron's exclusive warranty is that the Products will be free from defects in materials and workmanship for a period of twelve months from the date of sale by Omron (or such other period expressed in writing by Omron). Omron disclaims all other warranties, express or implied. (b) **Limitations.** OMRON MAKES NO WARRANTY OR REPRESENTATION, EXPRESS OR IMPLIED, ABOUT NON-INFRINGEMENT, MERCHANTABILITY OR FITNESS FOR A PARTICULAR PURPOSE OF THE PRODUCTS. BUYER ACKNOWLEDGES THAT IT ALONE HAS DETERMINED THAT THE PRODUCTS WILL SUITABLY MEET THE REQUIREMENTS OF THEIR INTENDED USE. Omron further disclaims all warranties and responsibility of any type for claims or expenses based on infringement by the Products or otherwise of any intellectual property right. (c) **Buyer Remedy.** Omron's sole obligation hereunder shall be, at Omron's election, to (i) replace (in the form originally shipped with Buyer responsible for labor charges for removal or replacement thereof) the non-complying Product, (ii) repair the non-complying Product, or (iii) repay or credit Buyer an amount equal to the purchase price of the non-complying Product; provided that in no event shall Omron be responsible for warranty, repair, indemnity or any other claims or expenses regarding the Products unless Omron's analysis confirms that the Products were properly handled, stored, installed and maintained and not subject to contamination, abuse, misuse or inappropriate modification. Return of any Products by Buyer must be approved in writing by Omron before shipment. Omron Companies shall not be liable for the suitability or unsuitability or the results from the use of Products in combination with any electrical or electronic components, circuits, system assemblies or any other materials or substances or environments. Any advice, recommendations or information given orally or in writing, are not to be construed as an amendment or addition to the above warranty. See <http://www.omron247.com> or contact your Omron representative for published information.
- Limitation on Liability; Etc.** OMRON COMPANIES SHALL NOT BE LIABLE FOR SPECIAL, INDIRECT, INCIDENTAL, OR CONSEQUENTIAL DAMAGES, LOSS OF PROFITS OR PRODUCTION OR COMMERCIAL LOSS IN ANY WAY CONNECTED WITH THE PRODUCTS, WHETHER SUCH CLAIM IS BASED IN CONTRACT, WARRANTY, NEGLIGENCE OR STRICT LIABILITY. Further, in no event shall liability of Omron Companies exceed the individual price of the Product on which liability is asserted.
- Indemnities.** Buyer shall indemnify and hold harmless Omron Companies and their employees from and against all liabilities, losses, claims, costs and expenses (including attorney's fees and expenses) related to any claim, investigation, litigation or proceeding (whether or not Omron is a party) which arises or is alleged to arise from Buyer's acts or omissions under these Terms or in any way with respect to the Products. Without limiting the foregoing, Buyer (at its own expense) shall indemnify and hold harmless Omron and defend or settle any action brought against such Companies to the extent based on a claim that any Product made to Buyer specifications infringed intellectual property rights of another party.
- Property; Confidentiality.** Any intellectual property in the Products is the exclusive property of Omron Companies and Buyer shall not attempt to duplicate it in any way without the written permission of Omron. Notwithstanding any charges to Buyer for engineering or tooling, all engineering and tooling shall remain the exclusive property of Omron. All information and materials supplied by Omron to Buyer relating to the Products are confidential and proprietary, and Buyer shall limit distribution thereof to its trusted employees and strictly prevent disclosure to any third party.
- Export Controls.** Buyer shall comply with all applicable laws, regulations and licenses regarding (i) export of products or information; (ii) sale of products to "forbidden" or other proscribed persons; and (iii) disclosure to non-citizens of regulated technology or information.
- Miscellaneous.** (a) **Waiver.** No failure or delay by Omron in exercising any right and no course of dealing between Buyer and Omron shall operate as a waiver of rights by Omron. (b) **Assignment.** Buyer may not assign its rights hereunder without Omron's written consent. (c) **Law.** These Terms are governed by the law of the jurisdiction of the home office of the Omron company from which Buyer is purchasing the Products (without regard to conflict of law principles). (d) **Amendment.** These Terms constitute the entire agreement between Buyer and Omron relating to the Products, and no provision may be changed or waived unless in writing signed by the parties. (e) **Severability.** If any provision hereof is rendered ineffective or invalid, such provision shall not invalidate any other provision. (f) **Setoff.** Buyer shall have no right to set off any amounts against the amount owing in respect of this invoice. (g) **Definitions.** As used herein, "including" means "including without limitation"; and "Omron Companies" (or similar words) mean Omron Corporation and any direct or indirect subsidiary or affiliate thereof.

Certain Precautions on Specifications and Use

- Suitability of Use.** Omron Companies shall not be responsible for conformity with any standards, codes or regulations which apply to the combination of the Product in the Buyer's application or use of the Product. At Buyer's request, Omron will provide applicable third party certification documents identifying ratings and limitations of use which apply to the Product. This information by itself is not sufficient for a complete determination of the suitability of the Product in combination with the end product, machine, system, or other application or use. Buyer shall be solely responsible for determining appropriateness of the particular Product with respect to Buyer's application, product or system. Buyer shall take application responsibility in all cases but the following is a non-exhaustive list of applications for which particular attention must be given:
 - Outdoor use, uses involving potential chemical contamination or electrical interference, or conditions or uses not described in this document.
 - Use in consumer products or any use in significant quantities.
 - Energy control systems, combustion systems, railroad systems, aviation systems, medical equipment, amusement machines, vehicles, safety equipment, and installations subject to separate industry or government regulations.
 - Systems, machines and equipment that could present a risk to life or property. Please know and observe all prohibitions of use applicable to this Product.

NEVER USE THE PRODUCT FOR AN APPLICATION INVOLVING SERIOUS RISK TO LIFE OR PROPERTY OR IN LARGE QUANTITIES WITHOUT ENSURING THAT THE SYSTEM AS A WHOLE HAS BEEN DESIGNED TO
- ADDRESS THE RISKS, AND THAT THE OMRON'S PRODUCT IS PROPERLY RATED AND INSTALLED FOR THE INTENDED USE WITHIN THE OVERALL EQUIPMENT OR SYSTEM.
- Programmable Products.** Omron Companies shall not be responsible for the user's programming of a programmable Product, or any consequence thereof.
- Performance Data.** Data presented in Omron Company websites, catalogs and other materials is provided as a guide for the user in determining suitability and does not constitute a warranty. It may represent the result of Omron's test conditions, and the user must correlate it to actual application requirements. Actual performance is subject to the Omron's Warranty and Limitations of Liability.
- Change in Specifications.** Product specifications and accessories may be changed at any time based on improvements and other reasons. It is our practice to change part numbers when published ratings or features are changed, or when significant construction changes are made. However, some specifications of the Product may be changed without any notice. When in doubt, special part numbers may be assigned to fix or establish key specifications for your application. Please consult with your Omron's representative at any time to confirm actual specifications of purchased Product.
- Errors and Omissions.** Information presented by Omron Companies has been checked and is believed to be accurate; however, no responsibility is assumed for clerical, typographical or proofreading errors or omissions.

OMRON

Automation...simple...powerful.

OMRON ELECTRONICS LLC • THE AMERICAS HEADQUARTERS

Schaumburg, IL USA • 847.843.7900 • 800.556.6766 • www.omron247.com

OMRON CANADA, INC. • HEAD OFFICE

Toronto, ON, Canada • 416.286.6465 • 866.986.6766 • www.omron.ca

OMRON ELETRÔNICA DO BRASIL LTDA • HEAD OFFICE

São Paulo, SP, Brasil • 55.11.2101.6300 • www.omron.com.br

OMRON ELECTRONICS MEXICO SA DE CV • HEAD OFFICE

Apodaca, N.L. • 52.811.156.99.10 • mela@omron.com

Cat. No. I531-E1-08

Note: Specifications are subject to change.

OMRON ARGENTINA • SALES OFFICE

Cono Sur • 54.11.4787.1129

OMRON CHILE • SALES OFFICE

Santiago 56.2206.4592

OTHER OMRON LATIN AMERICA SALES

56.2206.4592

© 2008 Omron Electronics LLC

Printed in U.S.A.