

Features

- 4 Mbit of Flash memory
- 2.3 V to 3.6 V single supply voltage
- SPI bus compatible serial interface
- 75 MHz clock rate (maximum)
- Page Program (up to 256 bytes) in 0.8 ms (typical)
- Sector Erase (512 Kbit) in 0.6 s (typical)
- Bulk Erase (4 Mbit) in 4.5 s (typical)
- Deep Power-down mode 1 μ A (typical)
- Hardware Write Protection: protected area size defined by three non-volatile bits (BP0, BP1 and BP2)
- Electronic signatures
 - JEDEC standard two-byte signature (2013h)
 - Unique ID code (UID) with 16 bytes read-only, available upon customer request
 - RES instruction, one-byte, signature (12h), for backward compatibility
- Packages
 - RoHS compliant
- Automotive grade parts available

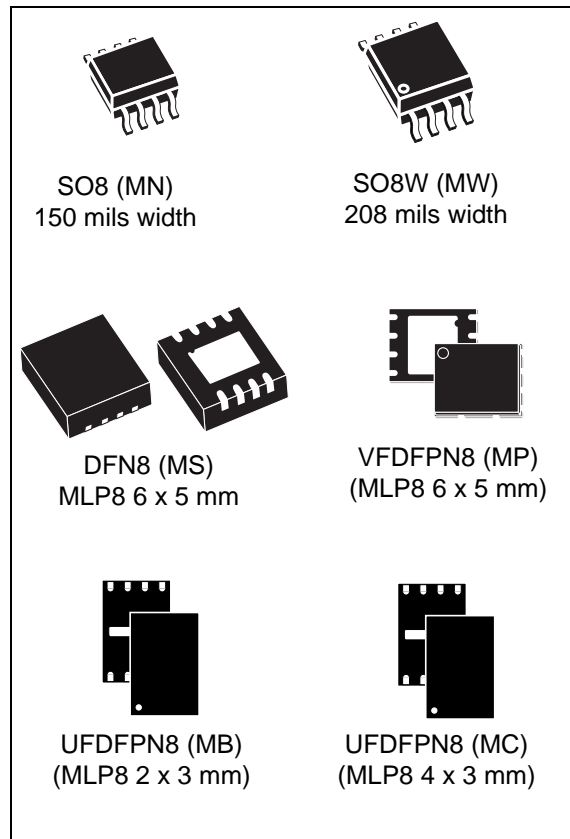

Contents

1	Description	6
2	Signal description	8
2.1	Serial Data output (Q)	8
2.2	Serial Data input (D)	8
2.3	Serial Clock (C)	8
2.4	Chip Select (\overline{S})	8
2.5	Hold (\overline{HOLD})	8
2.6	Write Protect (\overline{W})	8
2.7	V _{CC} supply voltage	9
2.8	V _{SS} ground	9
3	SPI modes	10
4	Operating features	12
4.1	Page Programming	12
4.2	Sector Erase and Bulk Erase	12
4.3	Polling during a Write, Program or Erase cycle	12
4.4	Active Power, Standby Power and Deep Power-down modes	12
4.5	Status Register	13
4.6	Protection modes	13
4.7	Hold condition	14
5	Memory organization	16
6	Instructions	18
6.1	Write Enable (WREN)	19
6.2	Write Disable (WRDI)	20
6.3	Read Identification (RDID)	21
6.4	Read Status Register (RDSR)	22
6.4.1	WIP bit	22
6.4.2	WEL bit	22
6.4.3	BP2, BP1, BP0 bits	23

6.4.4	SRWD bit	23
6.5	Write Status Register (WRSR)	24
6.6	Read Data Bytes (READ)	26
6.7	Read Data Bytes at Higher Speed (FAST_READ)	27
6.8	Page Program (PP)	28
6.9	Sector Erase (SE)	30
6.10	Bulk Erase (BE)	31
6.11	Deep Power-down (DP)	32
6.12	Release from Deep Power-down and Read Electronic Signature (RES)	33
7	Power-up and Power-down	35
8	Initial delivery state	37
9	Maximum rating	37
10	DC and AC parameters	38
11	Package mechanical	48
12	Ordering Information, Standard Parts	55
13	Ordering Information, Automotive Parts	57
14	Revision history	58

List of tables

Table 1.	Signal names	7
Table 2.	Protected area sizes	14
Table 3.	Memory organization	16
Table 4.	Instruction set	19
Table 5.	Read Identification (RDID) data-out sequence	21
Table 6.	Status Register format	22
Table 7.	Protection modes	25
Table 8.	Power-up timing and V_{WI} threshold	36
Table 9.	Absolute maximum ratings	37
Table 10.	Operating conditions	38
Table 11.	Device grade and AC table correlation	38
Table 12.	Data retention and endurance	38
Table 13.	Capacitance	38
Table 14.	DC characteristics (device grade 6)	39
Table 15.	DC characteristics (device grade 3)	40
Table 16.	Instruction times, process technology 110 nm	40
Table 17.	Instruction times, process technology 150 nm	41
Table 18.	AC measurement conditions	41
Table 19.	AC characteristics (25 MHz operation, device grade 3, V_{CC} min = 2.7 V)	42
Table 20.	AC characteristics (50 MHz operation, device grade 6, V_{CC} min = 2.7 V)	43
Table 21.	AC characteristics (*40 MHz operation, device grade 6, V_{CC} min = 2.3 V)	44
Table 22.	AC characteristics, 75 MHz operation, V_{CC} min = 2.7 V	45
Table 23.	SO8 narrow – 8 lead plastic Small Outline, 150 mils body width, package mechanical data	48
Table 24.	SO8 wide – 8 lead plastic small outline, 208 mils body width, package mechanical data	49
Table 25.	DFN8 (MLP8) 8-lead dual flat package no lead, 6 x 5 mm package mechanical data	50
Table 26.	VFDFPN8 (MLP8) 8-lead Very thin Fine pitch Dual Flat Package No lead, 6 x 5 mm, package mechanical data	51
Table 27.	UFDFPN8 (MLP8) 8-lead ultra thin fine pitch dual flat package no lead, 4 x 3 mm package mechanical data53	
Table 28.	UFDFPN8 (MLP8) 8-lead ultra thin fine pitch dual flat package no lead, 2 x 3 mm package mechanical data54	
Table 29.	Ordering information scheme	55
Table 30.	Ordering information scheme	57
Table 31.	Document revision history	58

List of figures

Figure 1.	Logic diagram	6
Figure 2.	SO and MLP8 connections	7
Figure 3.	Bus Master and memory devices on the SPI bus	10
Figure 4.	SPI modes supported	11
Figure 5.	Hold condition activation	15
Figure 6.	Block diagram	17
Figure 7.	Write Enable (WREN) instruction sequence	19
Figure 8.	Write Disable (WRDI) instruction sequence	20
Figure 9.	Read Identification (RDID) instruction sequence and data-out sequence	22
Figure 10.	Read Status Register (RDSR) instruction sequence and data-out sequence	23
Figure 11.	Write Status Register (WRSR) instruction sequence	24
Figure 12.	Read Data Bytes (READ) instruction sequence and data-out sequence	26
Figure 13.	Read Data Bytes at Higher Speed (FAST_READ) instruction sequence and data-out sequence	28
Figure 14.	Page Program (PP) instruction sequence	29
Figure 15.	Sector Erase (SE) instruction sequence	30
Figure 16.	Bulk Erase (BE) instruction sequence	31
Figure 17.	Deep Power-down (DP) instruction sequence	32
Figure 18.	Release from Deep Power-down and Read Electronic Signature (RES) instruction sequence and data-out sequence	34
Figure 19.	Release from Deep Power-down instruction sequence	34
Figure 20.	Power-up timing	36
Figure 21.	AC measurement I/O waveform	41
Figure 22.	Serial input timing	46
Figure 23.	Write Protect setup and hold timing during WRSR when SRWD = 1	46
Figure 24.	Hold timing	47
Figure 25.	Output timing	47
Figure 26.	SO8 narrow – 8 lead plastic Small Outline, 150 mils body width, package outline	48
Figure 27.	SO8W – 8 lead plastic small outline, 208 mils body width, package outline	49
Figure 28.	DFN8 (MLP8) 8-lead, dual flat package no lead, 6 x 5 mm, package outline	50
Figure 29.	VFDFPN8 (MLP8) 8-lead Very thin Fine pitch Quad Flat Package No lead, 6 x 5 mm, package outline	51
Figure 30.	UFDFPN8 (MLP8) 8-lead ultra thin fine pitch dual flat package no lead, 4 x 3 mm package mechanical data52	
Figure 31.	UFDFPN8 (MLP8) 8-lead ultra thin fine pitch dual flat package no lead, 2 x 3 mm package outline54	

1 Description

The M25P40 is a 4 Mbit (512 K × 8) Serial Flash memory, with advanced write protection mechanisms, accessed by a high speed SPI-compatible bus. The M25P40 features high performance instructions allowing clock frequency up to 75 MHz.⁽¹⁾

The memory can be programmed 1 to 256 bytes at a time, using the Page Program instruction.

The memory is organized as 8 sectors, each containing 256 pages. Each page is 256 bytes wide. Thus, the whole memory can be viewed as consisting of 2048 pages, or 524,288 bytes.

The whole memory can be erased using the Bulk Erase instruction, or a sector at a time, using the Sector Erase instruction.

In order to meet environmental requirements, Numonyx offers the M25P40 in RoHS compliant packages, which are Lead-free. RoHS specifications are available at: www.Numonyx.com.

Important: *This datasheet details the functionality of the M25P40 devices, based on the previous 150 nm process or based on the current 110 nm process (available since August 2008). The new device in the 110 nm process has the following additional features and is completely backward compatible with the old one in 150 nm:*

- improved max frequency (Fast Read) to 75 MHz in the standard Vcc range 2.7 V to 3.6 V, while the max frequency (Fast Read) in the extended Vcc range 2.3 V to 2.7 V is 40 MHz
- UID/CFD protection feature

Figure 1. Logic diagram

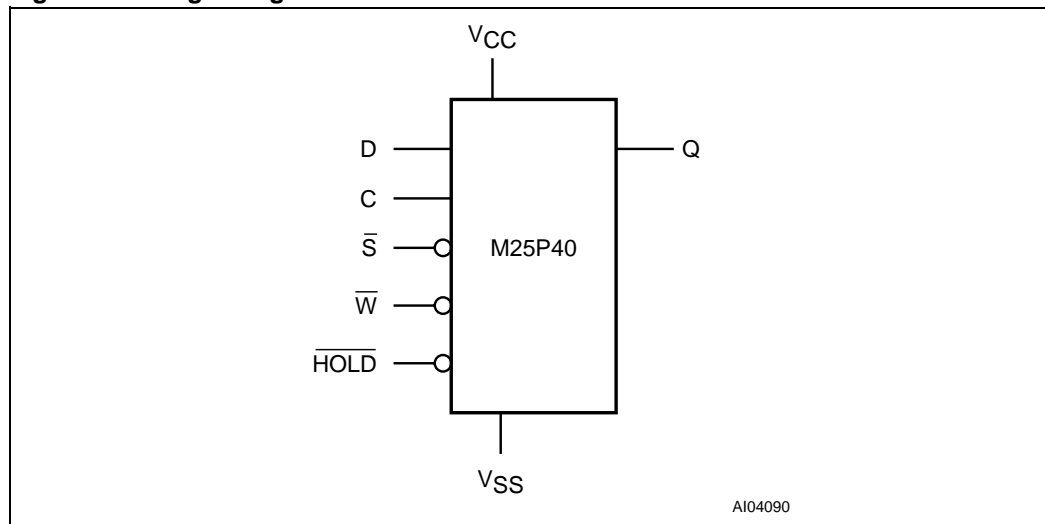

1. 75 MHz operation is available only on the VCC range 2.7 V - 3.6 V and for 110 nm process technology devices, identified by process identification digit "4" in the device marking and process letter "B" in the part number.

Table 1. Signal names

Signal name	Function	Direction
C	Serial Clock	Input
D	Serial Data input	Input
Q	Serial Data output	Output
\overline{S}	Chip Select	Input
\overline{W}	Write Protect	Input
\overline{HOLD}	Hold	Input
V_{CC}	Supply voltage	—
V_{SS}	Ground	—

Figure 2. SO and MLP8 connections

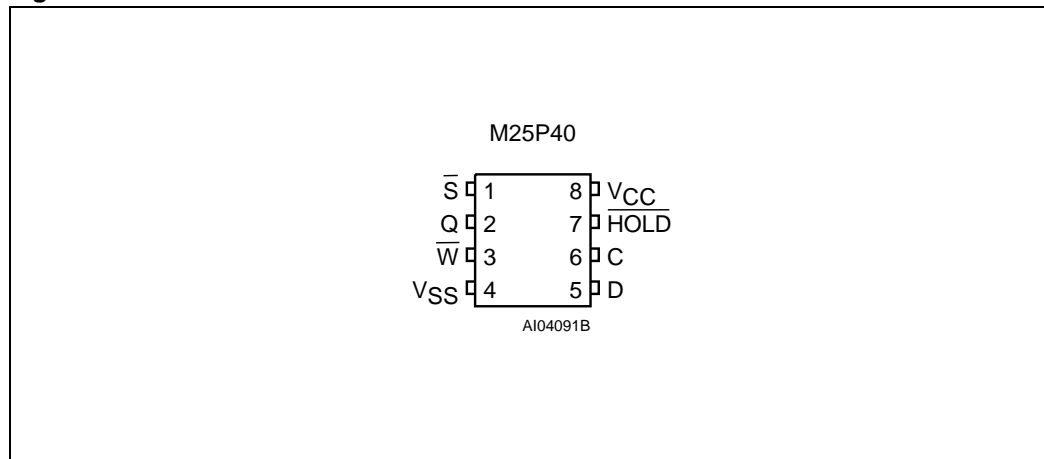

1. There is an exposed central pad on the underside of the MLP8 packages. This is pulled, internally, to V_{SS} , and must not be allowed to be connected to any other voltage or signal line on the PCB.
2. See [Section 11: Package mechanical](#) for package dimensions, and how to identify pin-1.

2 Signal description

2.1 Serial Data output (Q)

This output signal is used to transfer data serially out of the device. Data is shifted out on the falling edge of Serial Clock (C).

2.2 Serial Data input (D)

This input signal is used to transfer data serially into the device. It receives instructions, addresses, and the data to be programmed. Values are latched on the rising edge of Serial Clock (C).

2.3 Serial Clock (C)

This input signal provides the timing of the serial interface. Instructions, addresses, or data present at Serial Data input (D) are latched on the rising edge of Serial Clock (C). Data on Serial Data output (Q) changes after the falling edge of Serial Clock (C).

2.4 Chip Select (\overline{S})

When this input signal is High, the device is deselected and Serial Data output (Q) is at high impedance. Unless an internal Program, Erase or Write Status Register cycle is in progress, the device will be in the Standby Power mode (this is not the Deep Power-down mode). Driving Chip Select (\overline{S}) Low selects the device, placing it in the Active Power mode.

After Power-up, a falling edge on Chip Select (\overline{S}) is required prior to the start of any instruction.

2.5 Hold (\overline{HOLD})

The Hold (\overline{HOLD}) signal is used to pause any serial communications with the device without deselecting the device.

During the Hold condition, the Serial Data output (Q) is high impedance, and Serial Data input (D) and Serial Clock (C) are Don't Care.

To start the Hold condition, the device must be selected, with Chip Select (\overline{S}) driven Low.

2.6 Write Protect (\overline{W})

The main purpose of this input signal is to freeze the size of the area of memory that is protected against program or erase instructions (as specified by the values in the BP2, BP1 and BP0 bits of the Status Register).

2.7 V_{CC} supply voltage

V_{CC} is the supply voltage.

2.8 V_{SS} ground

V_{SS} is the reference for the V_{CC} supply voltage.

3 SPI modes

These devices can be driven by a microcontroller with its SPI peripheral running in either of the two following modes:

- CPOL=0, CPHA=0
- CPOL=1, CPHA=1

For these two modes, input data is latched in on the rising edge of Serial Clock (C), and output data is available from the falling edge of Serial Clock (C).

The difference between the two modes, as shown in [Figure 4](#), is the clock polarity when the bus master is in Stand-by mode and not transferring data:

- C remains at 0 for (CPOL=0, CPHA=0)
- C remains at 1 for (CPOL=1, CPHA=1)

Figure 3. Bus Master and memory devices on the SPI bus

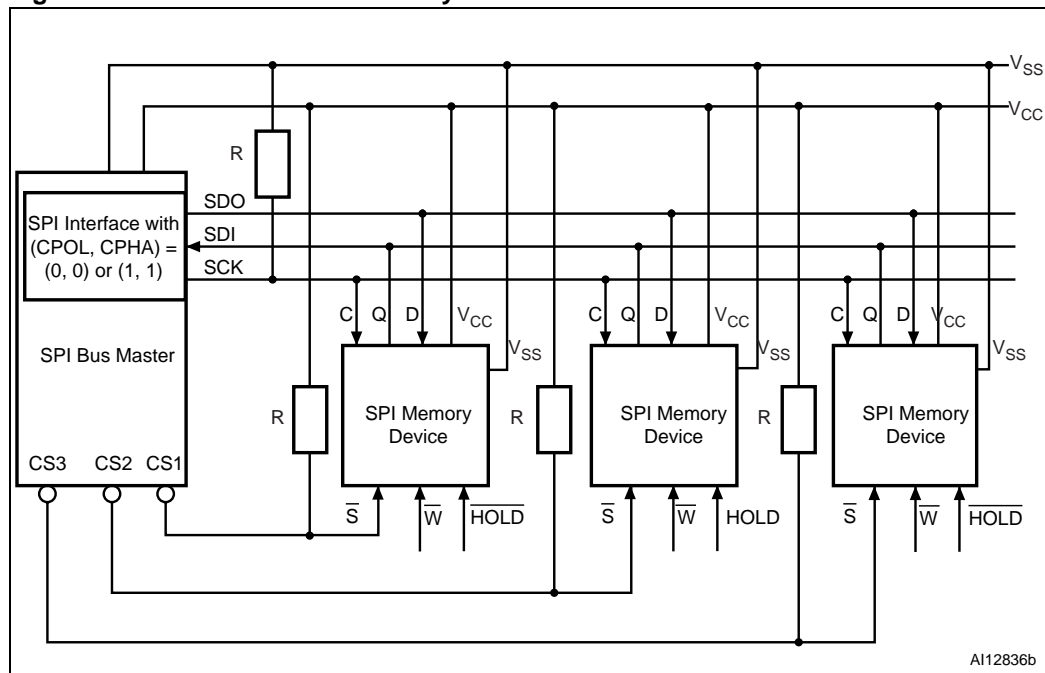

1. The Write Protect (\overline{W}) and Hold (\overline{HOLD}) signals should be driven, High or Low as appropriate.

[Figure 3: Bus Master and memory devices on the SPI bus](#) shows an example of three devices connected to an MCU, on an SPI bus. Only one device is selected at a time, so only one device drives the Serial Data output (Q) line at a time, the other devices are high impedance. Resistors R (represented in [Figure 3](#)) ensure that the M25P40 is not selected if the Bus Master leaves the S line in the high impedance state. As the Bus Master may enter a state where all inputs/outputs are in high impedance at the same time (for example, when the Bus Master is reset), the clock line (C) must be connected to an external pull-down resistor so that, when all inputs/outputs become high impedance, the \overline{S} line is pulled High while the C line is pulled Low (thus ensuring that \overline{S} and C do not become High at the same time, and so, that the t_{SHCH} requirement is met). The typical value of R is 100K Ω , assuming that the time constant $R \cdot C_p$ (C_p = parasitic capacitance of the bus line) is shorter than the time during which the Bus Master leaves the SPI bus in high impedance.

Example: $C_p = 50 \text{ pF}$, that is $R \cdot C_p = 5 \text{ }\mu\text{s}$: the application must ensure that the Bus Master never leaves the SPI bus in the high impedance state for a time period shorter than $5 \text{ }\mu\text{s}$.

Figure 4. SPI modes supported

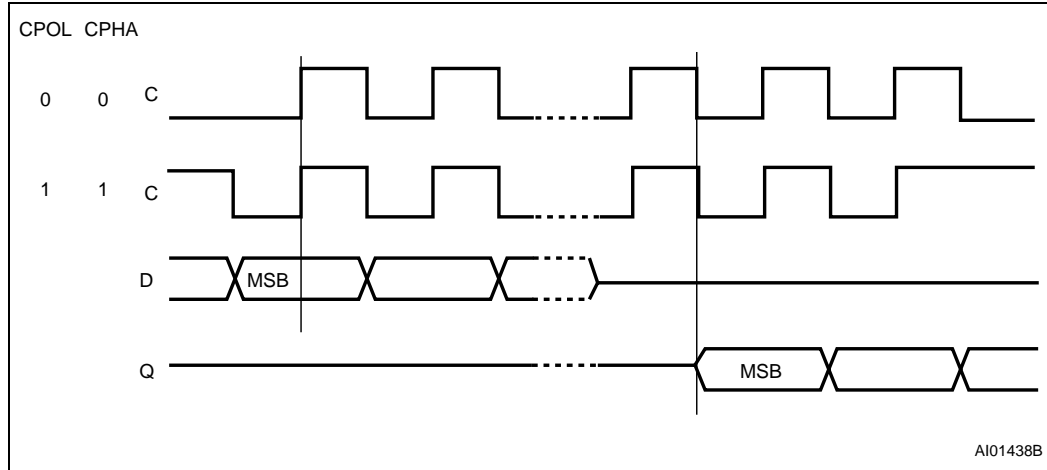

4 Operating features

4.1 Page Programming

To program one data byte, two instructions are required: Write Enable (WREN), which is one byte, and a Page Program (PP) sequence, which consists of four bytes plus data. This is followed by the internal Program cycle (of duration t_{PP}).

To spread this overhead, the Page Program (PP) instruction allows up to 256 bytes to be programmed at a time (changing bits from 1 to 0), provided that they lie in consecutive addresses on the same page of memory.

For optimized timings, it is recommended to use the Page Program (PP) instruction to program all consecutive targeted bytes in a single sequence versus using several Page Program (PP) sequences with each containing only a few bytes (See [Page Program \(PP\), Instruction times, process technology 110 nm.](#))

4.2 Sector Erase and Bulk Erase

The Page Program (PP) instruction allows bits to be reset from 1 to 0. Before this can be applied, the bytes of memory need to have been erased to all 1s (FFh). This can be achieved either a sector at a time, using the Sector Erase (SE) instruction, or throughout the entire memory, using the Bulk Erase (BE) instruction. This starts an internal Erase cycle (of duration t_{SE} or t_{BE}).

The Erase instruction must be preceded by a Write Enable (WREN) instruction.

4.3 Polling during a Write, Program or Erase cycle

A further improvement in the time to Write Status Register (WRSR), Program (PP) or Erase (SE or BE) can be achieved by not waiting for the worst case delay (t_W , t_{PP} , t_{SE} , or t_{BE}). The Write In Progress (WIP) bit is provided in the Status Register so that the application program can monitor its value, polling it to establish when the previous Write cycle, Program cycle or Erase cycle is complete.

4.4 Active Power, Standby Power and Deep Power-down modes

When Chip Select (\overline{S}) is Low, the device is selected, and in the Active Power mode.

When Chip Select (\overline{S}) is High, the device is deselected, but could remain in the Active Power mode until all internal cycles have completed (Program, Erase, Write Status Register). The device then goes in to the Standby Power mode. The device consumption drops to I_{CC1} .

The Deep Power-down mode is entered when the specific instruction (the Deep Power-down (DP) instruction) is executed. The device consumption drops further to I_{CC2} . The device remains in this mode until another specific instruction (the Release from Deep Power-down and Read Electronic Signature (RES) instruction) is executed.

All other instructions are ignored while the device is in the Deep Power-down mode. This can be used as an extra software protection mechanism, when the device is not in active use, to protect the device from inadvertent Write, Program or Erase instructions.

4.5 Status Register

The Status Register contains a number of status and control bits that can be read or set (as appropriate) by specific instructions. For a detailed description of the Status Register bits, see [Section 6.4: Read Status Register \(RDSR\)](#).

4.6 Protection modes

The environments where non-volatile memory devices are used can be very noisy. No SPI device can operate correctly in the presence of excessive noise. To help combat this, the M25P40 features the following data protection mechanisms:

- Power On Reset and an internal timer (t_{PUW}) can provide protection against inadvertent changes while the power supply is outside the operating specification.
- Program, Erase and Write Status Register instructions are checked that they consist of a number of clock pulses that is a multiple of eight, before they are accepted for execution.
- All instructions that modify data must be preceded by a Write Enable (WREN) instruction to set the Write Enable Latch (WEL) bit. This bit is returned to its reset state after the following events:
 - Power-up
 - Write Disable (WRDI) instruction completion
 - Write Status Register (WRSR) instruction completion
 - Page Program (PP) instruction completion
 - Sector Erase (SE) instruction completion
 - Bulk Erase (BE) instruction completion
- Software Protected Mode (SPM): The Block Protect (BP2, BP1, BP0) bits allow part of the memory to be configured as read-only.
- Hardware Protected Mode (HPM): The Write Protect (\overline{W}) signal allows the Block Protect (BP2, BP1, BP0) bits and Status Register Write Disable (SRWD) bit to be protected.

In addition to the low power consumption feature, the Deep Power-down mode offers extra software protection from inadvertent Write, Program, and Erase instructions, as all instructions are ignored except the Release from Deep Power-down instruction.

Table 2. Protected area sizes

Status Register content			Memory content	
BP2 bit	BP1 bit	BP0 bit	Protected area	Unprotected area
0	0	0	none	All sectors ⁽¹⁾ (eight sectors: 0 to 7)
0	0	1	Upper eighth (Sector 7)	Lower seven-eighths (seven sectors: 0 to 6)
0	1	0	Upper quarter (two sectors: 6 and 7)	Lower three-quarters (six sectors: 0 to 5)
0	1	1	Upper half (four sectors: 4 to 7)	Lower half (four sectors: 0 to 3)
1	0	0	All sectors (eight sectors: 0 to 7)	none
1	0	1	All sectors (eight sectors: 0 to 7)	none
1	1	0	All sectors (eight sectors: 0 to 7)	none
1	1	1	All sectors (eight sectors: 0 to 7)	none

1. The device is ready to accept a Bulk Erase instruction only if all Block Protect bits (BP2, BP1, BP0) are 0.

4.7 Hold condition

The Hold ($\overline{\text{HOLD}}$) signal is used to pause any serial communications with the device without resetting the clocking sequence. However, taking this signal Low does not terminate any Write Status Register, Program or Erase cycle that is currently in progress.

To enter the Hold condition, the device must be selected, with Chip Select ($\overline{\text{S}}$) Low.

The Hold condition starts on the falling edge of the Hold ($\overline{\text{HOLD}}$) signal, provided that this coincides with Serial Clock (C) being Low (as shown in [Figure 5: Hold condition activation](#)).

The Hold condition ends on the rising edge of the Hold ($\overline{\text{HOLD}}$) signal, provided that this coincides with Serial Clock (C) being Low.

If the falling edge does not coincide with Serial Clock (C) being Low, the Hold condition starts after Serial Clock (C) next goes Low. Similarly, if the rising edge does not coincide with Serial Clock (C) being Low, the Hold condition ends after Serial Clock (C) next goes Low. (This is shown in [Figure 5: Hold condition activation](#)).

During the Hold condition, the Serial Data output (Q) is high impedance, and Serial Data input (D) and Serial Clock (C) are Don't Care.

Normally, the device is kept selected, with Chip Select ($\overline{\text{S}}$) driven Low, for the whole duration of the Hold condition. This is to ensure that the state of the internal logic remains unchanged from the moment of entering the Hold condition.

If Chip Select ($\overline{\text{S}}$) goes High while the device is in the Hold condition, this has the effect of resetting the internal logic of the device. To restart communication with the device, it is necessary to drive Hold ($\overline{\text{HOLD}}$) High, and then to drive Chip Select ($\overline{\text{S}}$) Low. This prevents the device from going back to the Hold condition.

Figure 5. Hold condition activation

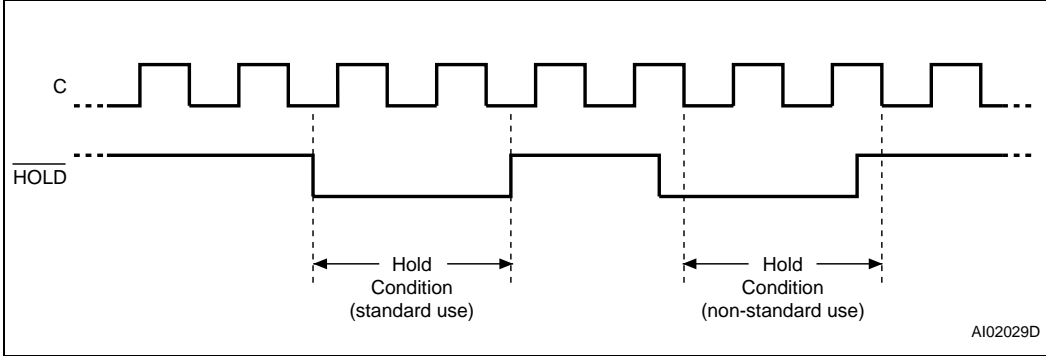

5 Memory organization

The memory is organized as:

- 524,288 bytes (8 bits each)
- 8 sectors (512 Kbits, 65,536 bytes each)
- 2048 pages (256 bytes each)

Each page can be individually programmed (bits are programmed from 1 to 0). The device is Sector or Bulk Erasable (bits are erased from 0 to 1) but not Page Erasable.

Table 3. Memory organization

Sector	Address range	
7	70000h	7FFFFh
6	60000h	6FFFFh
5	50000h	5FFFFh
4	40000h	4FFFFh
3	30000h	3FFFFh
2	20000h	2FFFFh
1	10000h	1FFFFh
0	00000h	0FFFFh

Figure 6. Block diagram

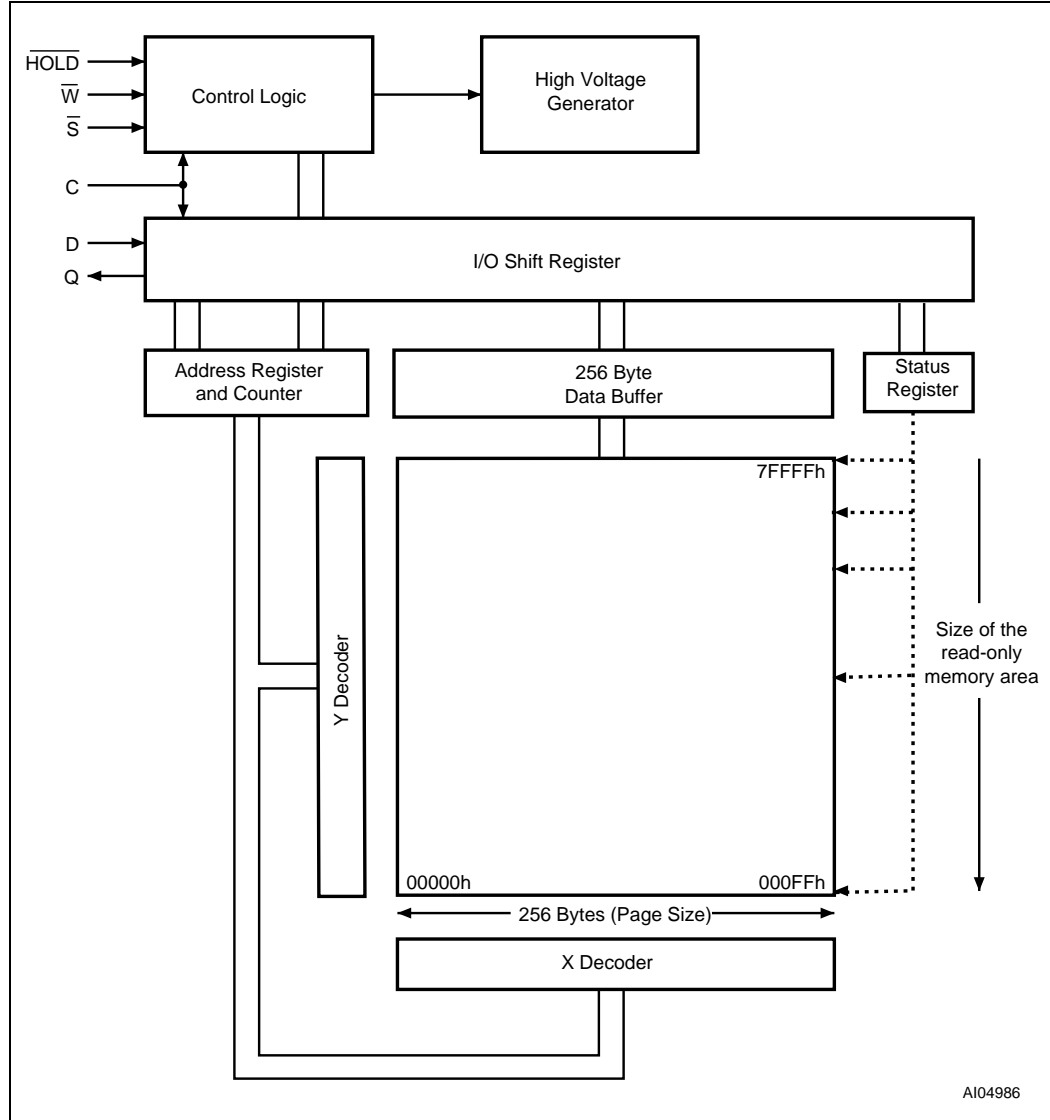

6 Instructions

All instructions, addresses and data are shifted in and out of the device, most significant bit first.

Serial Data input (D) is sampled on the first rising edge of Serial Clock (C) after Chip Select (\bar{S}) is driven Low. Then, the one-byte instruction code must be shifted in to the device, most significant bit first, on Serial Data input (D), each bit being latched on the rising edges of Serial Clock (C).

The instruction set is listed in [Table 4](#).

Every instruction sequence starts with a one-byte instruction code. Depending on the instruction, this might be followed by address bytes, or by data bytes, or by both or none. Chip Select (\bar{S}) must be driven High after the last bit of the instruction sequence has been shifted in.

In the case of a Read Data Bytes (READ), Read Data Bytes at Higher Speed (Fast_Read), Read Identification (RDID), Read Status Register (RDSR) or Release from Deep Power-down, and Read Electronic Signature (RES) instruction, the shifted-in instruction sequence is followed by a data-out sequence. Chip Select (\bar{S}) can be driven High after any bit of the data-out sequence is being shifted out.

In the case of a Page Program (PP), Sector Erase (SE), Bulk Erase (BE), Write Status Register (WRSR), Write Enable (WREN), Write Disable (WRDI) or Deep Power-down (DP) instruction, Chip Select (\bar{S}) must be driven High exactly at a byte boundary, otherwise the instruction is rejected, and is not executed. That is, Chip Select (\bar{S}) must be driven High when the number of clock pulses after Chip Select (\bar{S}) being driven Low is an exact multiple of eight.

All attempts to access the memory array during a Write Status Register cycle, Program cycle or Erase cycle are ignored, and the internal Write Status Register cycle, Program cycle or Erase cycle continues unaffected.

6.2 Write Disable (WRDI)

The Write Disable (WRDI) instruction (*Figure 8*) resets the Write Enable Latch (WEL) bit.

The Write Disable (WRDI) instruction is entered by driving Chip Select (\overline{S}) Low, sending the instruction code, and then driving Chip Select (\overline{S}) High.

The Write Enable Latch (WEL) bit is reset under the following conditions:

- Power-up
- Write Disable (WRDI) instruction completion
- Write Status Register (WRSR) instruction completion
- Page Program (PP) instruction completion
- Sector Erase (SE) instruction completion
- Bulk Erase (BE) instruction completion

Figure 8. Write Disable (WRDI) instruction sequence

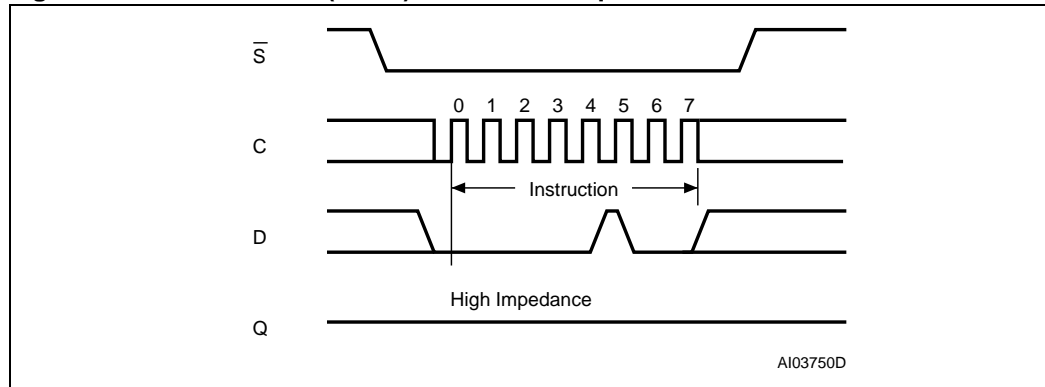

6.3 Read Identification (RDID)

The Read Identification (RDID) instruction reads the device identification data:

- Manufacturer identification (1 byte)
- Device identification (2 bytes)
- Unique ID code (UID) (17 bytes, 16 which are available upon customer request).⁽²⁾

The manufacturer identification is assigned by JEDEC, and has the value 20h for Numonyx. The device identification is assigned by the device manufacturer, and indicates the memory type in the first byte (20h), and the memory capacity of the device in the second byte (13h). The UID contains the length of the following data in the first byte (set to 10h), and 16 bytes of the optional Customized Factory Data (CFD) content. The CFD bytes are read-only and can be programmed with customers data upon their demand. If the customers do not make requests, the devices are shipped with all the CFD bytes programmed to zero (00h). Any Read Identification (RDID) instruction while an Erase or Program cycle is in progress, is not decoded, and has no effect on the cycle that is in progress. The device is first selected by driving Chip Select (S) Low. Then, the 8-bit instruction code for the instruction is shifted in. After this, the 24-bit device identification, stored in the memory, the 8-bit CFD length followed by 16 bytes of CFD content will be shifted out on Serial Data output (Q). Each bit is shifted out during the falling edge of Serial Clock (C).

The instruction sequence is shown in [Figure 9: Read Identification \(RDID\) instruction sequence and data-out sequence](#).

The Read Identification (RDID) instruction is terminated by driving Chip Select (\bar{S}) High at any time during data output.

When Chip Select (\bar{S}) is driven High, the device is put in the Stand-by Power mode. Once in the Stand-by Power mode, the device waits to be selected, so that it can receive, decode and execute instructions.

Table 5. Read Identification (RDID) data-out sequence

Manufacturer identification	Device identification		UID	
	Memory type	Memory capacity	CFD length	CFD content
20h	20h	13h	10h	16 bytes

2. The UID feature is available only for 110 nm process technology devices, identified by process identification digit "4" in the device marking and process letter "B" in the part number.

Figure 9. Read Identification (RDID) instruction sequence and data-out sequence

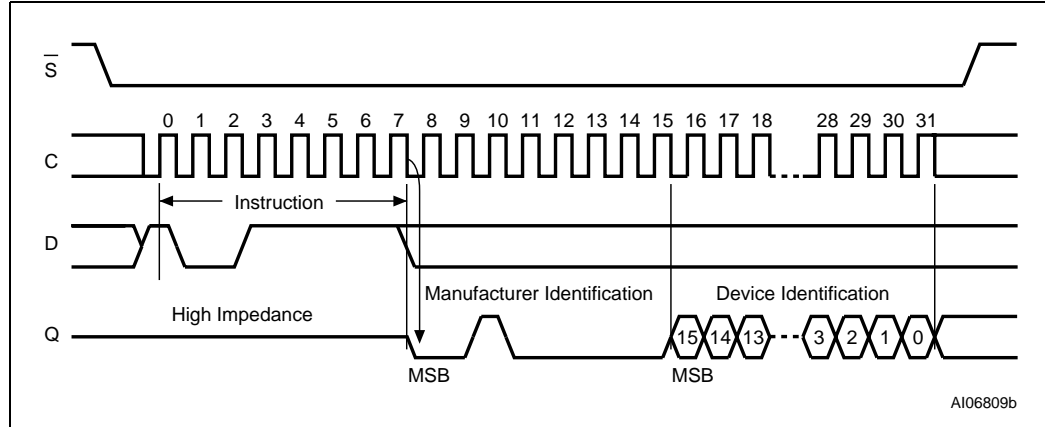

6.4 Read Status Register (RDSR)

The Read Status Register (RDSR) instruction allows the Status Register to be read. The Status Register may be read at any time, even while a Program, Erase or Write Status Register cycle is in progress. When one of these cycles is in progress, it is recommended to check the Write In Progress (WIP) bit before sending a new instruction to the device. It is also possible to read the Status Register continuously, as shown in [Figure 10](#).

Table 6. Status Register format

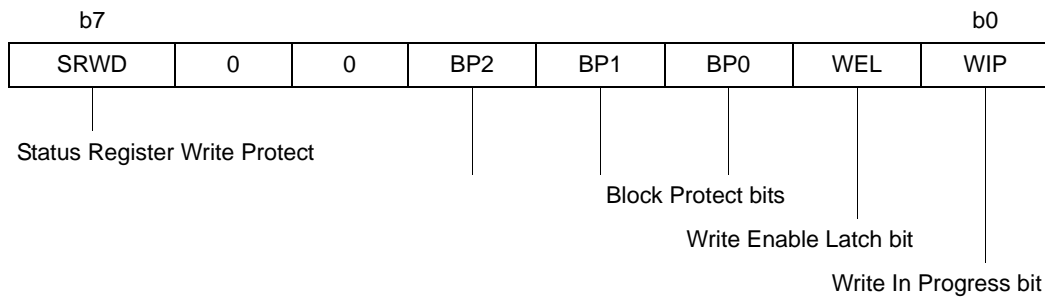

The status and control bits of the Status Register are as follows:

6.4.1 WIP bit

The Write In Progress (WIP) bit indicates whether the memory is busy with a Write Status Register, Program or Erase cycle. When set to 1, such a cycle is in progress, when reset to 0 no such cycle is in progress.

6.4.2 WEL bit

The Write Enable Latch (WEL) bit indicates the status of the internal Write Enable Latch. When set to 1 the internal Write Enable Latch is set, when set to 0 the internal Write Enable Latch is reset and no Write Status Register, Program or Erase instruction is accepted.

6.4.3 BP2, BP1, BP0 bits

The Block Protect (BP2, BP1, BP0) bits are non-volatile. They define the size of the area to be software protected against Program and Erase instructions. These bits are written with the Write Status Register (WRSR) instruction. When one or more of the Block Protect (BP2, BP1, BP0) bits is set to 1, the relevant memory area (as defined in [Table 2](#)) becomes protected against Page Program (PP) and Sector Erase (SE) instructions. The Block Protect (BP2, BP1, BP0) bits can be written provided that the Hardware Protected mode has not been set. The Bulk Erase (BE) instruction is executed if, and only if, all Block Protect (BP2, BP1, BP0) bits are 0.

6.4.4 SRWD bit

The Status Register Write Disable (SRWD) bit is operated in conjunction with the Write Protect (\bar{W}) signal. The Status Register Write Disable (SRWD) bit and Write Protect (\bar{W}) signal allow the device to be put in the Hardware Protected mode (when the Status Register Write Disable (SRWD) bit is set to 1, and Write Protect (\bar{W}) is driven Low). In this mode, the non-volatile bits of the Status Register (SRWD, BP2, BP1, BP0) become read-only bits and the Write Status Register (WRSR) instruction is no longer accepted for execution.

Figure 10. Read Status Register (RDSR) instruction sequence and data-out sequence

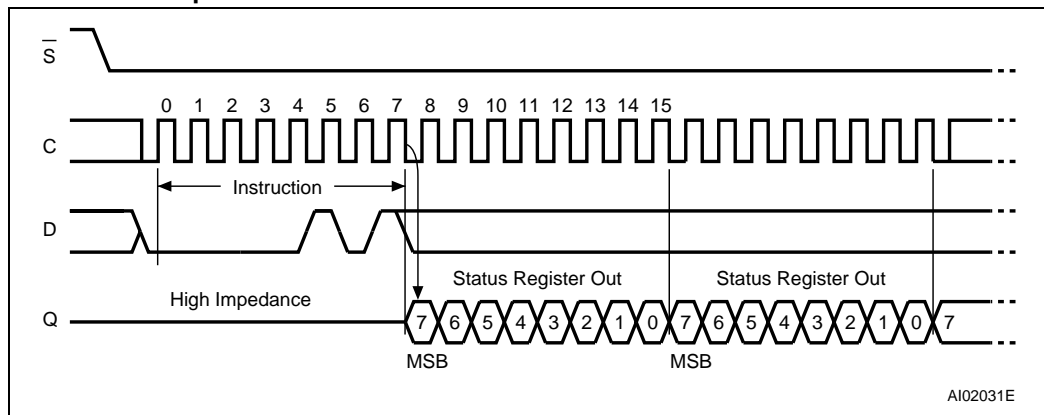

6.5 Write Status Register (WRSR)

The Write Status Register (WRSR) instruction allows new values to be written to the Status Register. Before it can be accepted, a Write Enable (WREN) instruction must previously have been executed. After the Write Enable (WREN) instruction has been decoded and executed, the device sets the Write Enable Latch (WEL).

The Write Status Register (WRSR) instruction is entered by driving Chip Select (\bar{S}) Low, followed by the instruction code and the data byte on Serial Data input (D).

The instruction sequence is shown in [Figure 11](#).

The Write Status Register (WRSR) instruction has no effect on b6, b5, b1 and b0 of the Status Register. b6 and b5 are always read as 0.

Chip Select (\bar{S}) must be driven High after the eighth bit of the data byte has been latched in. If not, the Write Status Register (WRSR) instruction is not executed. As soon as Chip Select (\bar{S}) is driven High, the self-timed Write Status Register cycle (whose duration is t_W) is initiated. While the Write Status Register cycle is in progress, the Status Register may still be read to check the value of the Write In Progress (WIP) bit. The Write In Progress (WIP) bit is 1 during the self-timed Write Status Register cycle, and is 0 when it is completed. When the cycle is completed, the Write Enable Latch (WEL) is reset.

The Write Status Register (WRSR) instruction allows the user to change the values of the Block Protect (BP2, BP1, BP0) bits, to define the size of the area that is to be treated as read-only, as defined in [Table 2](#). The Write Status Register (WRSR) instruction also allows the user to set or reset the Status Register Write Disable (SRWD) bit in accordance with the Write Protect (\bar{W}) signal. The Status Register Write Disable (SRWD) bit and Write Protect (\bar{W}) signal allow the device to be put in the Hardware Protected Mode (HPM). The Write Status Register (WRSR) instruction is not executed once the Hardware Protected Mode (HPM) is entered.

Figure 11. Write Status Register (WRSR) instruction sequence

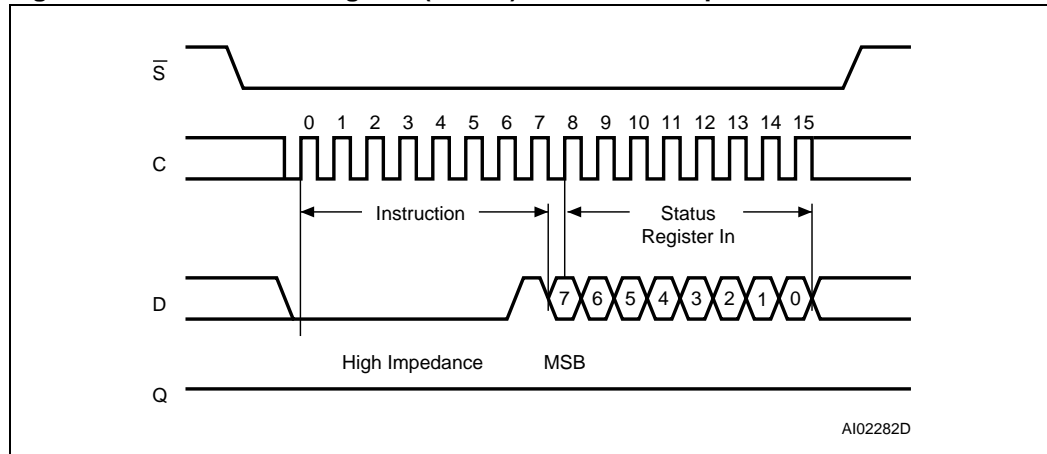

Table 7. Protection modes

\overline{W} signal	SRWD bit	Mode	Write Protection of the Status Register	Memory content	
				Protected area ⁽¹⁾	Unprotected area ⁽¹⁾
1	0	Software Protected (SPM)	Status Register is Writable (if the WREN instruction has set the WEL bit) The values in the SRWD, BP2, BP1 and BP0 bits can be changed	Protected against Page Program, Sector Erase and Bulk Erase	Ready to accept Page Program and Sector Erase instructions
0	0				
1	1	Hardware Protected (HPM)	Status Register is Hardware write protected The values in the SRWD, BP2, BP1 and BP0 bits cannot be changed	Protected against Page Program, Sector Erase and Bulk Erase	Ready to accept Page Program and Sector Erase instructions
0	1				

1. As defined by the values in the Block Protect (BP2, BP1, BP0) bits of the Status Register, as shown in [Table 2](#).

The protection features of the device are summarized in [Table 7](#).

When the Status Register Write Disable (SRWD) bit of the Status Register is 0 (its initial delivery state), it is possible to write to the Status Register provided that the Write Enable Latch (WEL) bit has previously been set by a Write Enable (WREN) instruction, regardless of the whether Write Protect (\overline{W}) is driven High or Low.

When the Status Register Write Disable (SRWD) bit of the Status Register is set to 1, two cases need to be considered, depending on the state of Write Protect (\overline{W}):

- If Write Protect (\overline{W}) is driven High, it is possible to write to the Status Register provided that the Write Enable Latch (WEL) bit has previously been set by a Write Enable (WREN) instruction.
- If Write Protect (\overline{W}) is driven Low, it is *not* possible to write to the Status Register *even* if the Write Enable Latch (WEL) bit has previously been set by a Write Enable (WREN) instruction. (Attempts to write to the Status Register are rejected, and are not accepted for execution). As a consequence, all the data bytes in the memory area that are software protected (SPM) by the Block Protect (BP2, BP1, BP0) bits of the Status Register, are also hardware protected against data modification.

Regardless of the order of the two events, the Hardware Protected Mode (HPM) can be entered:

- by setting the Status Register Write Disable (SRWD) bit after driving Write Protect (\overline{W}) Low
- or by driving Write Protect (\overline{W}) Low after setting the Status Register Write Disable (SRWD) bit.

The only way to exit the Hardware Protected Mode (HPM) once entered is to pull Write Protect (\overline{W}) High.

If Write Protect (\overline{W}) is permanently tied High, the Hardware Protected Mode (HPM) can never be activated, and only the Software Protected Mode (SPM), using the Block Protect (BP2, BP1, BP0) bits of the Status Register, can be used.

6.6 Read Data Bytes (READ)

The device is first selected by driving Chip Select (\overline{S}) Low. The instruction code for the Read Data Bytes (READ) instruction is followed by a 3-byte address (A23-A0), each bit being latched-in during the rising edge of Serial Clock (C). Then the memory contents, at that address, is shifted out on Serial Data output (Q), each bit being shifted out, at a maximum frequency f_R , during the falling edge of Serial Clock (C).

The instruction sequence is shown in *Figure 12*.

The first byte addressed can be at any location. The address is automatically incremented to the next higher address after each byte of data is shifted out. The whole memory can, therefore, be read with a single Read Data Bytes (READ) instruction. When the highest address is reached, the address counter rolls over to 000000h, allowing the read sequence to be continued indefinitely.

The Read Data Bytes (READ) instruction is terminated by driving Chip Select (\overline{S}) High. Chip Select (\overline{S}) can be driven High at any time during data output. Any Read Data Bytes (READ) instruction, while an Erase, Program or Write cycle is in progress, is rejected without having any effects on the cycle that is in progress.

Figure 12. Read Data Bytes (READ) instruction sequence and data-out sequence

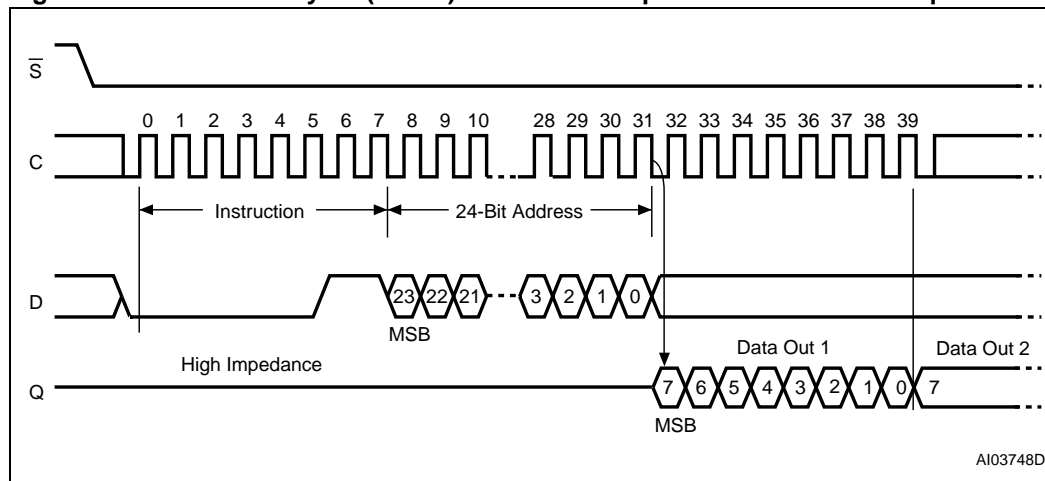

1. Address bits A23 to A19 are Don't Care.

6.7 Read Data Bytes at Higher Speed (FAST_READ)

The device is first selected by driving Chip Select (\overline{S}) Low. The instruction code for the Read Data Bytes at Higher Speed (FAST_READ) instruction is followed by a 3-byte address (A23-A0) and a dummy byte, each bit being latched-in during the rising edge of Serial Clock (C). Then the memory contents, at that address, is shifted out on Serial Data output (Q), each bit being shifted out, at a maximum frequency f_C , during the falling edge of Serial Clock (C).

The instruction sequence is shown in *Figure 13*.

The first byte addressed can be at any location. The address is automatically incremented to the next higher address after each byte of data is shifted out. The whole memory can, therefore, be read with a single Read Data Bytes at Higher Speed (FAST_READ) instruction. When the highest address is reached, the address counter rolls over to 000000h, allowing the read sequence to be continued indefinitely.

The Read Data Bytes at Higher Speed (FAST_READ) instruction is terminated by driving Chip Select (\overline{S}) High. Chip Select (\overline{S}) can be driven High at any time during data output. Any Read Data Bytes at Higher Speed (FAST_READ) instruction, while an Erase, Program or Write cycle is in progress, is rejected without having any effects on the cycle that is in progress.

Figure 13. Read Data Bytes at Higher Speed (FAST_READ) instruction sequence and data-out sequence

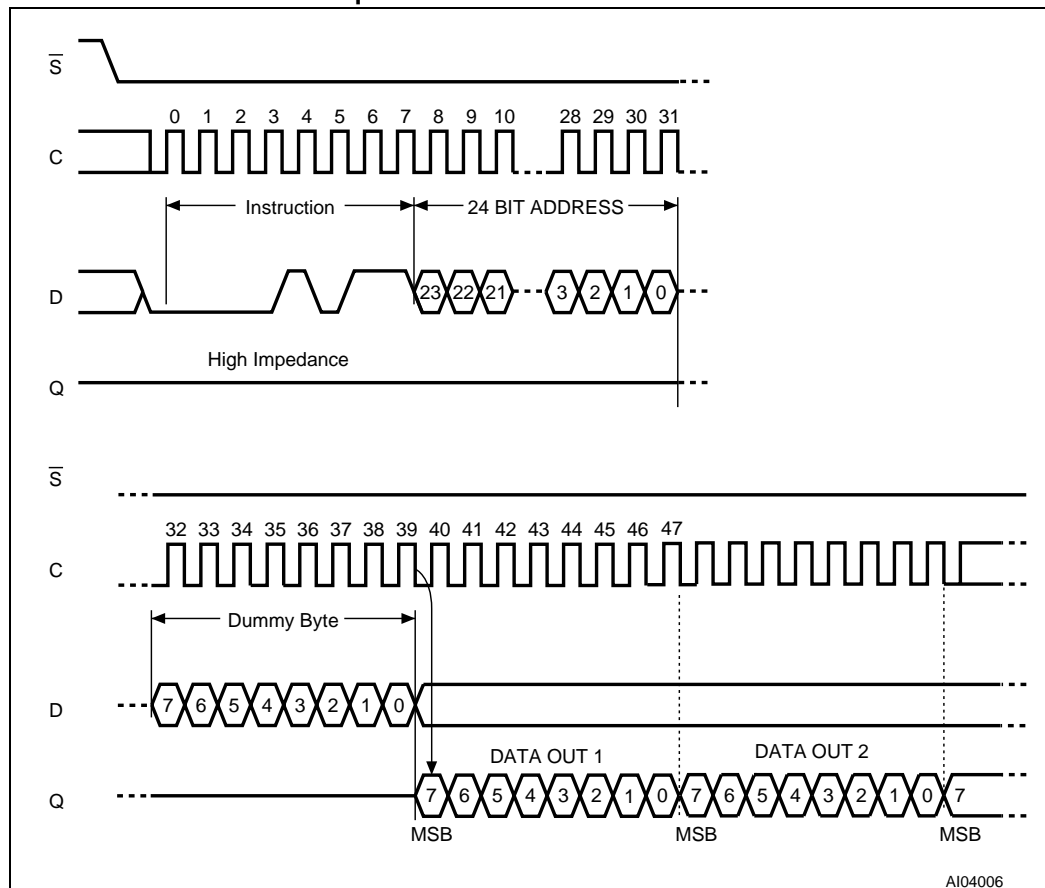

1. Address bits A23 to A19 are Don't Care.

6.8 Page Program (PP)

The Page Program (PP) instruction allows bytes to be programmed in the memory (changing bits from 1 to 0). Before it can be accepted, a Write Enable (WREN) instruction must previously have been executed. After the Write Enable (WREN) instruction has been decoded, the device sets the Write Enable Latch (WEL).

The Page Program (PP) instruction is entered by driving Chip Select (\overline{S}) Low, followed by the instruction code, three address bytes and at least one data byte on Serial Data input (D). If the 8 least significant address bits (A7-A0) are not all zero, all transmitted data that goes beyond the end of the current page are programmed from the start address of the same page (from the address whose 8 least significant bits (A7-A0) are all zero). Chip Select (\overline{S}) must be driven Low for the entire duration of the sequence.

The instruction sequence is shown in [Figure 14](#).

If more than 256 bytes are sent to the device, previously latched data are discarded and the last 256 data bytes are guaranteed to be programmed correctly within the same page. If less than 256 Data bytes are sent to device, they are correctly programmed at the requested addresses without having any effects on the other bytes of the same page.

For optimized timings, it is recommended to use the Page Program (PP) instruction to program all consecutive targeted bytes in a single sequence versus using several Page Program (PP) sequences with each containing only a few bytes (see [Instruction times, process technology 110 nm](#)).

Chip Select (\overline{S}) must be driven High after the eighth bit of the last data byte has been latched in, otherwise the Page Program (PP) instruction is not executed.

As soon as Chip Select (\overline{S}) is driven High, the self-timed Page Program cycle (whose duration is t_{PP}) is initiated. While the Page Program cycle is in progress, the Status Register may be read to check the value of the Write In Progress (WIP) bit. The Write In Progress (WIP) bit is 1 during the self-timed Page Program cycle, and is 0 when it is completed. At some unspecified time before the cycle is completed, the Write Enable Latch (WEL) bit is reset.

A Page Program (PP) instruction applied to a page which is protected by the Block Protect (BP2, BP1, BP0) bits (see [Table 3](#) and [Table 2](#)) is not executed.

Figure 14. Page Program (PP) instruction sequence

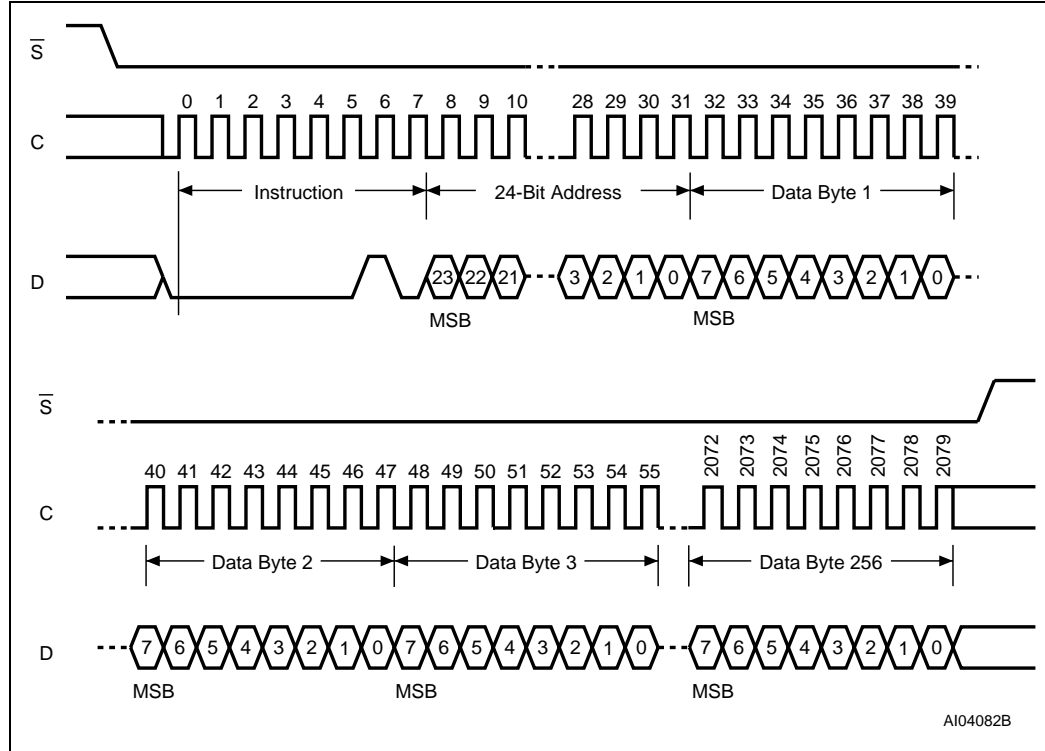

1. Address bits A23 to A19 are Don't Care.

6.9 Sector Erase (SE)

The Sector Erase (SE) instruction sets to 1 (FFh) all bits inside the chosen sector. Before it can be accepted, a Write Enable (WREN) instruction must previously have been executed. After the Write Enable (WREN) instruction has been decoded, the device sets the Write Enable Latch (WEL).

The Sector Erase (SE) instruction is entered by driving Chip Select (\bar{S}) Low, followed by the instruction code, and three address bytes on Serial Data input (D). Any address inside the Sector (see [Table 3](#)) is a valid address for the Sector Erase (SE) instruction. Chip Select (\bar{S}) must be driven Low for the entire duration of the sequence.

The instruction sequence is shown in [Figure 15](#).

Chip Select (\bar{S}) must be driven High after the eighth bit of the last address byte has been latched in, otherwise the Sector Erase (SE) instruction is not executed. As soon as Chip Select (\bar{S}) is driven High, the self-timed Sector Erase cycle (whose duration is t_{SE}) is initiated. While the Sector Erase cycle is in progress, the Status Register may be read to check the value of the Write In Progress (WIP) bit. The Write In Progress (WIP) bit is 1 during the self-timed Sector Erase cycle, and is 0 when it is completed. At some unspecified time before the cycle is completed, the Write Enable Latch (WEL) bit is reset.

A Sector Erase (SE) instruction applied to a page which is protected by the Block Protect (BP2, BP1, BP0) bits (see [Table 3](#) and [Table 2](#)) is not executed.

Figure 15. Sector Erase (SE) instruction sequence

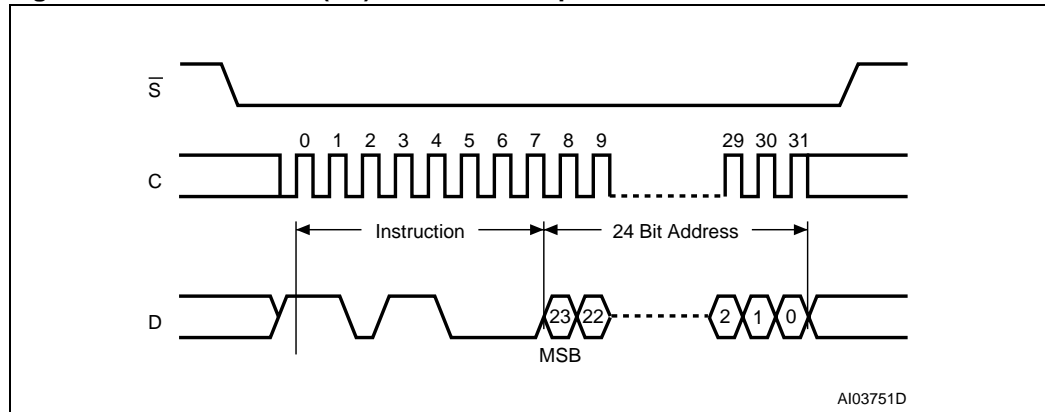

1. Address bits A23 to A19 are Don't Care.

6.10 Bulk Erase (BE)

The Bulk Erase (BE) instruction sets all bits to 1 (FFh). Before it can be accepted, a Write Enable (WREN) instruction must previously have been executed. After the Write Enable (WREN) instruction has been decoded, the device sets the Write Enable Latch (WEL).

The Bulk Erase (BE) instruction is entered by driving Chip Select (\overline{S}) Low, followed by the instruction code on Serial Data input (D). Chip Select (\overline{S}) must be driven Low for the entire duration of the sequence.

The instruction sequence is shown in [Figure 16](#).

Chip Select (\overline{S}) must be driven High after the eighth bit of the instruction code has been latched in, otherwise the Bulk Erase instruction is not executed. As soon as Chip Select (\overline{S}) is driven High, the self-timed Bulk Erase cycle (whose duration is t_{BE}) is initiated. While the Bulk Erase cycle is in progress, the Status Register may be read to check the value of the Write In Progress (WIP) bit. The Write In Progress (WIP) bit is 1 during the self-timed Bulk Erase cycle, and is 0 when it is completed. At some unspecified time before the cycle is completed, the Write Enable Latch (WEL) bit is reset.

The Bulk Erase (BE) instruction is executed only if all Block Protect (BP2, BP1, BP0) bits are 0. The Bulk Erase (BE) instruction is ignored if one, or more, sectors are protected.

Figure 16. Bulk Erase (BE) instruction sequence

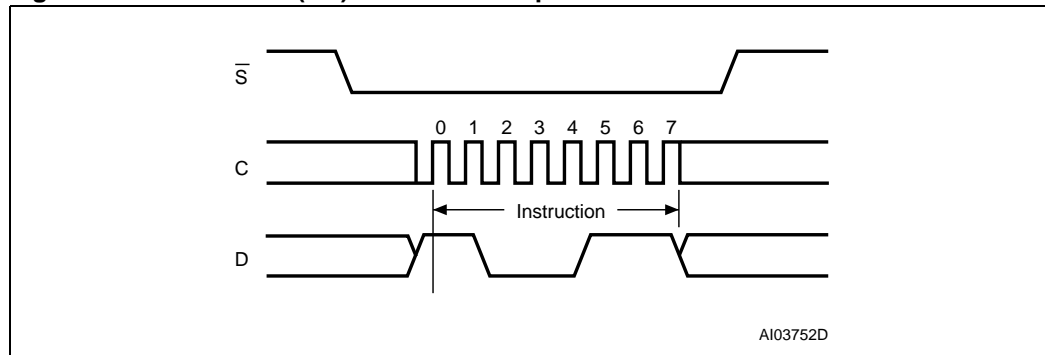

6.11 Deep Power-down (DP)

Executing the Deep Power-down (DP) instruction is the only way to put the device in the lowest consumption mode (the Deep Power-down mode). It can also be used as an extra software protection mechanism, while the device is not in active use, since in this mode, the device ignores all Write, Program and Erase instructions.

Driving Chip Select (\bar{S}) High deselects the device, and puts the device in the Standby Power mode (if there is no internal cycle currently in progress). But this mode is not the Deep Power-down mode. The Deep Power-down mode can only be entered by executing the Deep Power-down (DP) instruction, subsequently reducing the standby current (from I_{CC1} to I_{CC2} , as specified in [Table 14](#)).

Once the device has entered the Deep Power-down mode, all instructions are ignored except the Release from Deep Power-down and Read Electronic Signature (RES) instruction. This releases the device from this mode. The Release from Deep Power-down and Read Electronic Signature (RES) instruction and the Read Identification (RDID) instruction also allow the Electronic Signature of the device to be output on Serial Data output (Q).

The Deep Power-down mode automatically stops at Power-down, and the device always Powers-up in the Standby Power mode.

The Deep Power-down (DP) instruction is entered by driving Chip Select (\bar{S}) Low, followed by the instruction code on Serial Data input (D). Chip Select (\bar{S}) must be driven Low for the entire duration of the sequence.

The instruction sequence is shown in [Figure 17](#).

Chip Select (\bar{S}) must be driven High after the eighth bit of the instruction code has been latched in, otherwise the Deep Power-down (DP) instruction is not executed. As soon as Chip Select (\bar{S}) is driven High, it requires a delay of t_{DP} before the supply current is reduced to I_{CC2} and the Deep Power-down mode is entered.

Any Deep Power-down (DP) instruction, while an Erase, Program or Write cycle is in progress, is rejected without having any effects on the cycle that is in progress.

Figure 17. Deep Power-down (DP) instruction sequence

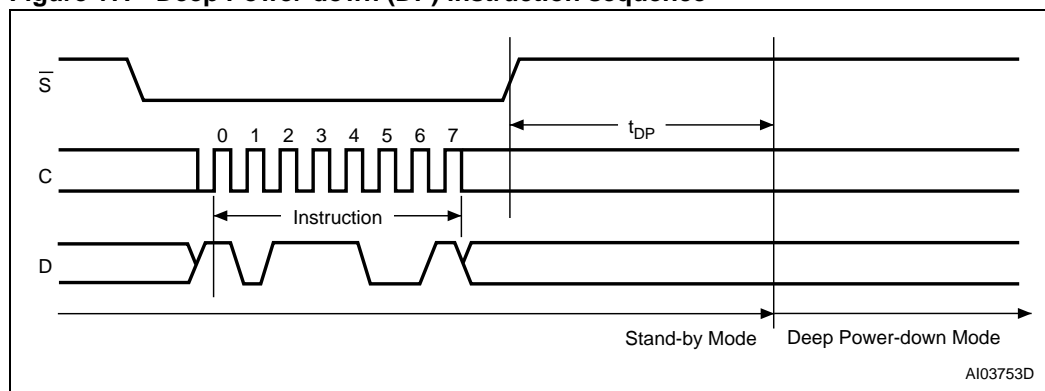

6.12 Release from Deep Power-down and Read Electronic Signature (RES)

Once the device has entered the Deep Power-down mode, all instructions are ignored except the Release from Deep Power-down and Read Electronic Signature (RES) instruction. Executing this instruction takes the device out of the Deep Power-down mode.

The instruction can also be used to read, on Serial Data output (Q), the 8-bit Electronic Signature, whose value for the *M25P40* is *12h*.

Except while an Erase, Program or Write Status Register cycle is in progress, the Release from Deep Power-down and Read Electronic Signature (RES) instruction always provides access to the 8-bit Electronic Signature of the device, and can be applied even if the Deep Power-down mode has not been entered.

Any Release from Deep Power-down and Read Electronic Signature (RES) instruction while an Erase, Program or Write Status Register cycle is in progress, is not decoded, and has no effect on the cycle that is in progress.

The device is first selected by driving Chip Select (\bar{S}) Low. The instruction code is followed by 3 dummy bytes, each bit being latched-in on Serial Data input (D) during the rising edge of Serial Clock (C). Then, the 8-bit Electronic Signature, stored in the memory, is shifted out on Serial Data output (Q), each bit being shifted out during the falling edge of Serial Clock (C).

The instruction sequence is shown in [Figure 18](#).

The Release from Deep Power-down and Read Electronic Signature (RES) instruction is terminated by driving Chip Select (\bar{S}) High after the Electronic Signature has been read at least once. Sending additional clock cycles on Serial Clock (C), while Chip Select (\bar{S}) is driven Low, cause the Electronic Signature to be output repeatedly.

When Chip Select (\bar{S}) is driven High, the device is put in the Standby Power mode. If the device was not previously in the Deep Power-down mode, the transition to the Standby Power mode is immediate. If the device was previously in the Deep Power-down mode, though, the transition to the Standby Power mode is delayed by t_{RES2} , and Chip Select (\bar{S}) must remain High for at least $t_{RES2}(max)$, as specified in [Table 19](#). Once in the Standby Power mode, the device waits to be selected, so that it can receive, decode and execute instructions.

Driving Chip Select (\bar{S}) High after the 8-bit instruction byte has been received by the device, but before the whole of the 8-bit Electronic Signature has been transmitted for the first time (as shown in [Figure 19](#)), still ensures that the device is put into Standby Power mode. If the device was not previously in the Deep Power-down mode, the transition to the Standby Power mode is immediate. If the device was previously in the Deep Power-down mode, though, the transition to the Standby Power mode is delayed by t_{RES1} , and Chip Select (\bar{S}) must remain High for at least $t_{RES1}(max)$, as specified in [Table 19](#). Once in the Standby Power mode, the device waits to be selected, so that it can receive, decode and execute instructions.

Figure 18. Release from Deep Power-down and Read Electronic Signature (RES) instruction sequence and data-out sequence

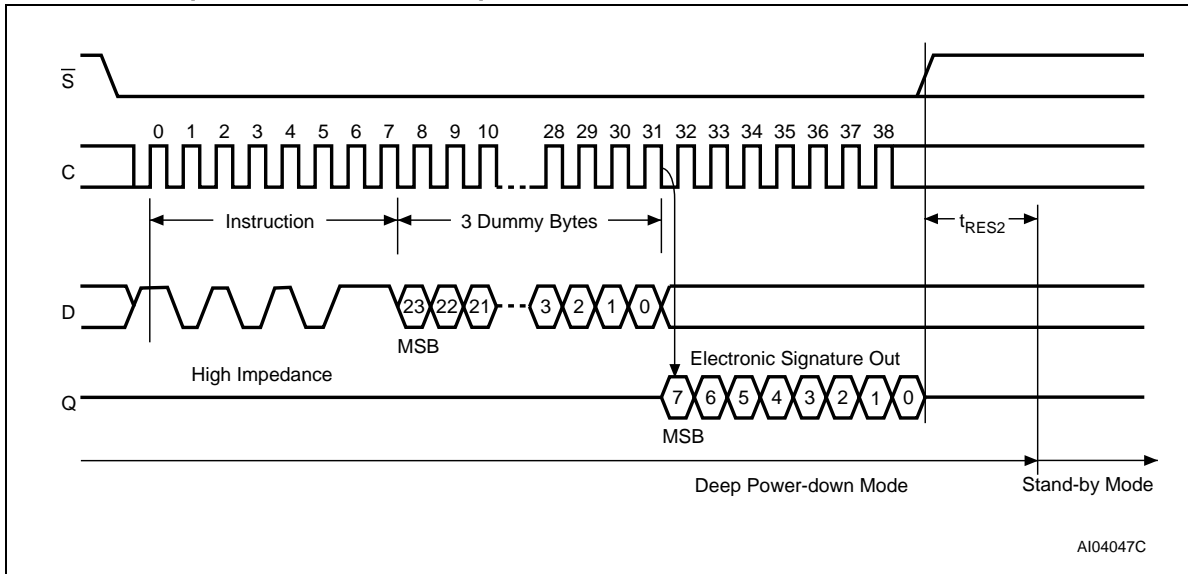

1. The value of the 8-bit Electronic Signature, for the M25P40, is 12h.

Figure 19. Release from Deep Power-down instruction sequence

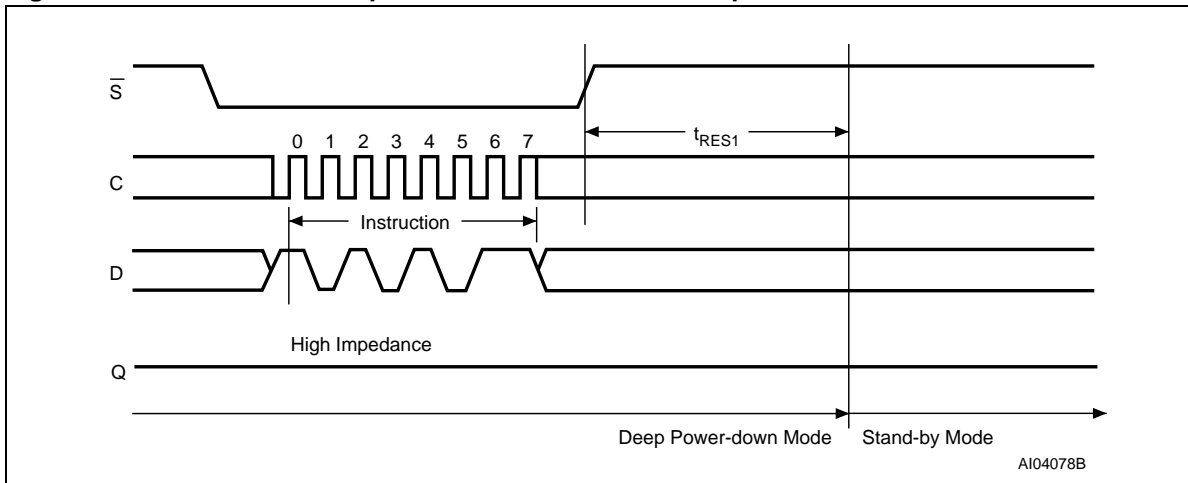

7 Power-up and Power-down

At Power-up and Power-down, the device must not be selected (that is Chip Select (\bar{S}) must follow the voltage applied on V_{CC}) until V_{CC} reaches the correct value:

- $V_{CC}(\text{min})$ at Power-up, and then for a further delay of t_{VSL}
- V_{SS} at Power-down

A safe configuration is provided in [Section 3: SPI modes](#).

To avoid data corruption and inadvertent write operations during power-up, a Power-On Reset (POR) circuit is included. The logic inside the device is held reset while V_{CC} is less than the Power-On Reset (POR) threshold voltage, V_{WI} – all operations are disabled, and the device does not respond to any instruction.

Moreover, the device ignores all Write Enable (WREN), Page Program (PP), Sector Erase (SE), Bulk Erase (BE) and Write Status Register (WRSR) instructions until a time delay of t_{PUW} has elapsed after the moment that V_{CC} rises above the V_{WI} threshold. However, the correct operation of the device is not guaranteed if, by this time, V_{CC} is still below $V_{CC}(\text{min})$. No Write Status Register, Program, or Erase instructions should be sent until the later occurrence of:

- t_{PUW} after V_{CC} passed the V_{WI} threshold
- t_{VSL} after V_{CC} passed the $V_{CC}(\text{min})$ level

These values are specified in [Table 9: Absolute maximum ratings](#).

If the delay, t_{VSL} , has elapsed, after V_{CC} has risen above $V_{CC}(\text{min})$, the device can be selected for READ instructions even if the t_{PUW} delay is not yet fully elapsed.

At Power-up, the device is in the following state:

- The device is in the Standby Power mode (not the Deep Power-down mode).
- The Write Enable Latch (WEL) bit is reset.
- The Write In Progress (WIP) bit is reset.

Normal precautions must be taken for supply rail decoupling, to stabilize the V_{CC} supply. Each device in a system should have the V_{CC} rail decoupled by a suitable capacitor close to the package pins. (Generally, this capacitor is of the order of 100 nF.)

At Power-down, when V_{CC} drops from the operating voltage, to below the Power On Reset (POR) threshold voltage, V_{WI} , all operations are disabled and the device does not respond to any instruction. (The designer needs to be aware that if a Power-down occurs while a Write, Program or Erase cycle is in progress, some data corruption can result.)

Figure 20. Power-up timing

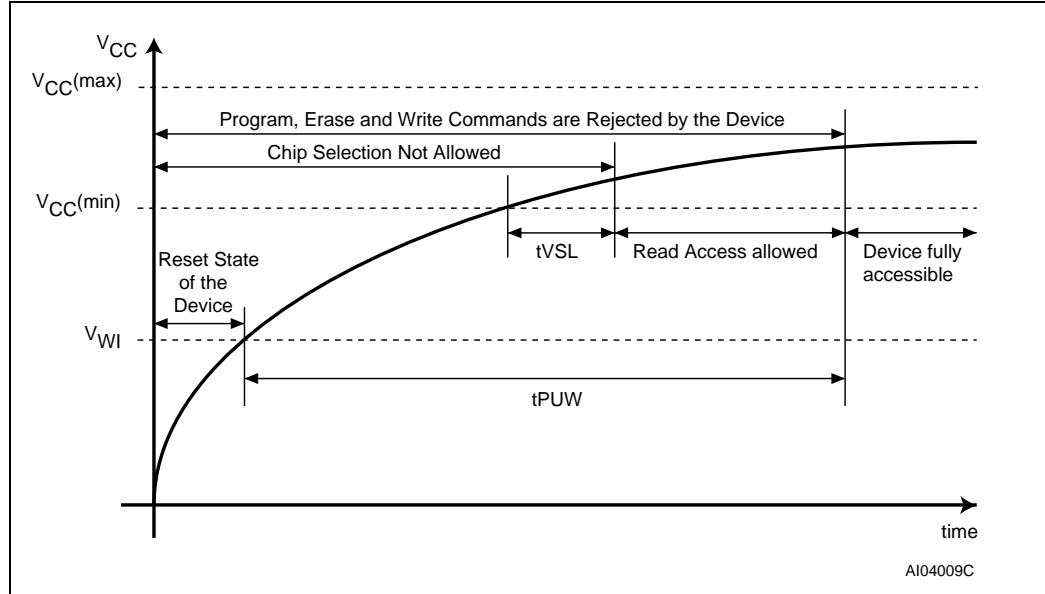

Table 8. Power-up timing and V_{WI} threshold

Symbol	Parameter	Min.	Max.	Unit
t _{VSL} ⁽¹⁾	V _{CC(min)} to \bar{S} low	10	—	μs
t _{PUW} ⁽¹⁾	Time delay to Write instruction	1	10	ms
V _{WI} ⁽¹⁾	Write Inhibit voltage (device grade 6)	1	2.1	V
	Write Inhibit voltage (device grade 3)	1	2.1	V

1. These parameters are characterized only.

8 Initial delivery state

The device is delivered with the memory array erased: all bits are set to 1 (each byte contains FFh). The Status Register contains 00h (all Status Register bits are 0).

9 Maximum rating

Stressing the device above the rating listed in the Absolute maximum ratings table may cause permanent damage to the device. These are stress ratings only and operation of the device at these or any other conditions above those indicated in the operating sections of this specification is not implied. Exposure to absolute maximum rating conditions for extended periods may affect device reliability. Refer also to the Numonyx SURE Program and other relevant quality documents.

Table 9. Absolute maximum ratings

Symbol	Parameter	Min.	Max.	Unit
T _{STG}	Storage temperature	-65	150	°C
T _{LEAD}	Lead temperature during soldering	—	see ⁽¹⁾	°C
V _{IO}	Input and output voltage (with respect to Ground) ⁽²⁾	-0.6	V _{CC} + 0.6	V
V _{CC}	Supply voltage	-0.6	4.0	V
V _{ESD}	Electrostatic Discharge voltage (Human Body model) ⁽³⁾	-2000	2000	V

1. Compliant with JEDEC Std J-STD-020C (for small body, Sn-Pb or Pb assembly) and the European directive on Restrictions on Hazardous Substances (RoHS) 2002/95/EU.
2. The minimum voltage may reach the value of -2 V for no more than 20 ns during transitions; The maximum voltage may reach the value of V_{CC}+2 V for no more than 20 ns during transitions.
3. JEDEC Std JESD22-A114A (C1 = 100 pF, R1 = 1500 Ω, R2 = 500 Ω).

10 DC and AC parameters

This section summarizes the operating and measurement conditions, and the DC and AC characteristics of the device. The parameters in the DC and AC characteristic tables that follow are derived from tests performed under the Measurement Conditions summarized in the relevant tables. Designers should check that the operating conditions in their circuit match the measurement conditions when relying on the quoted parameters.

Table 10. Operating conditions

Symbol	Parameter	Min.	Max.	Unit
V_{CC}	Supply voltage	2.3	3.6	V
T_A	Ambient operating temperature (device grade 6)	-40	85	°C
	Ambient operating temperature (device grade 3)	-40	125	

Table 11. Device grade and AC table correlation

Device Grade	150nm Version			110nm		
	Vcc(min)	f (max)	AC Table	Vcc(min)	f (max)	AC Table
Grade 3	2.7V	25 MHz	Table 19.	2.7V	75 MHz	Table 22.
Grade 6	2.3V	40 MHz	Table 21.	2.3V	40 MHz	Table 21.
Grade 6	2.7V	50 MHz	Table 20.	2.7V	75 MHz	Table 22.

Table 12. Data retention and endurance

Parameter	Condition	Min.	Max.	Unit
Erase/Program cycles	Device grade 6	100,000	—	cycles per sector
	Device grade 3	100,000	—	
Data Retention	at 55°C	20	—	years

Table 13. Capacitance⁽¹⁾

Symbol	Parameter	Test condition	Min.	Max.	Unit
C_{OUT}	Output capacitance (Q)	$V_{OUT} = 0\text{ V}$	—	8	pF
C_{IN}	Input capacitance (other pins)	$V_{IN} = 0\text{ V}$	—	6	pF

1. Sampled only, not 100% tested, at $T_A = 25\text{ °C}$ and a frequency of 25 MHz.

Table 14. DC characteristics (device grade 6)

Symbol	Parameter	Test condition (in addition to those in Table 10)	Min.	Max.	Unit
I_{LI}	Input leakage current	—	—	± 2	μA
I_{LO}	Output leakage current	—	—	± 2	μA
I_{CC1}	Standby current	$\bar{S} = V_{CC}, V_{IN} = V_{SS} \text{ or } V_{CC}$	—	50	μA
I_{CC2}	Deep Power-down current	$\bar{S} = V_{CC}, V_{IN} = V_{SS} \text{ or } V_{CC}$	—	10	μA
I_{CC3}	Operating current (READ)	C = 0.1 V_{CC} / 0.9 V_{CC} at 40 MHz, 50 MHz, and 75 MHz, Q = open	—	8	mA
		C = 0.1 V_{CC} / 0.9 V_{CC} at 25 MHz and 33 MHz, Q = open	—	4	mA
I_{CC4}	Operating current (PP)	$\bar{S} = V_{CC}$	—	15	mA
I_{CC5}	Operating current (WRSR)	$\bar{S} = V_{CC}$	—	15	mA
I_{CC6}	Operating current (SE)	$\bar{S} = V_{CC}$	—	15	mA
I_{CC7}	Operating current (BE)	$\bar{S} = V_{CC}$	—	15	mA
V_{IL}	Input low voltage	—	-0.5	0.3 V_{CC}	V
V_{IH}	Input high voltage	—	0.7 V_{CC}	$V_{CC}+0.4$	V
V_{OL}	Output low voltage	$I_{OL} = 1.6 \text{ mA}$	—	0.4	V
V_{OH}	Output high voltage	$I_{OH} = -100 \mu\text{A}$	$V_{CC}-0.2$	—	V

Table 15. DC characteristics (device grade 3)

Symbol	Parameter	Test condition (in addition to those in Table 10)	Min ⁽¹⁾	Max ⁽¹⁾	Unit
I_{LI}	Input leakage current	—	—	± 2	μA
I_{LO}	Output leakage current	—	—	± 2	μA
I_{CC1}	Standby current	$\bar{S} = V_{CC}, V_{IN} = V_{SS} \text{ or } V_{CC}$	—	100	μA
I_{CC2}	Deep Power-down current	$\bar{S} = V_{CC}, V_{IN} = V_{SS} \text{ or } V_{CC}$	—	50	μA
I_{CC3}	Operating current (READ)	$C = 0.1V_{CC} / 0.9.V_{CC}$ at 25 MHz and 75 MHz, Q = open	—	8	mA
		$C = 0.1V_{CC} / 0.9.V_{CC}$ at 20 MHz and 33 MHz, Q = open	—	4	mA
I_{CC4}	Operating current (PP)	$\bar{S} = V_{CC}$	—	15	mA
I_{CC5}	Operating current (WRSR)	$\bar{S} = V_{CC}$	—	15	mA
I_{CC6}	Operating current (SE)	$\bar{S} = V_{CC}$	—	15	mA
I_{CC7}	Operating current (BE)	$\bar{S} = V_{CC}$	—	15	mA
V_{IL}	Input low voltage	—	-0.5	$0.3V_{CC}$	V
V_{IH}	Input high voltage	—	$0.7V_{CC}$	$V_{CC}+0.4$	V
V_{OL}	Output low voltage	$I_{OL} = 1.6 \text{ mA}$	—	0.4	V
V_{OH}	Output high voltage	$I_{OH} = -100 \mu\text{A}$	$V_{CC}-0.2$	—	V

1. This is preliminary data.

Table 16. Instruction times, process technology 110 nm ⁽¹⁾

Test conditions specified in Table 10 and Table 18						
Symbol	Alt.	Parameter	Min.	Typ.	Max.	Unit
t_W	—	Write Status Register cycle time	—	1.3	15	ms
$t_{PP}^{(2)}$	—	Page Program cycle time (256 bytes)	—	0.8	5	ms
	—	Page Program cycle time (n bytes)	—	$\text{int}(n/8) \times 0.025^{(2)}$		
t_{SE}	—	Sector Erase cycle time	—	0.6	3	s
t_{BE}	—	Bulk Erase cycle time	—	4.5	10	s

1. 110 nm technology devices are identified by process identification digit "4" in the device marking and process letter "B" in the part number.

2. When using the Page Program (PP) instruction to program consecutive bytes, optimized timings are obtained with one sequence including all the bytes versus several sequences of only a few bytes ($1 \leq n \leq 256$).

Table 17. Instruction times, process technology 150 nm⁽¹⁾

Test conditions specified in Table 10 and Table 18						
Symbol	Alt.	Parameter	Min.	Typ.	Max.	Unit
t_W	—	Write Status Register cycle time	—	5	15	ms
$t_{PP}^{(2)}$	—	Page Program cycle time (256 bytes)	—	1.4	5	ms
		Page Program cycle time (n bytes)	—	$0.4+n*1/256^{(2)}$		
t_{SE}	—	Sector Erase cycle time	—	1	3	s
t_{BE}	—	Bulk Erase cycle time	—	4.5	10	s

- 150 nm technology devices are identified by process identification digit "X" in the device marking.
- When using the Page Program (PP) instruction to program consecutive bytes, optimized timings are obtained with one sequence including all the bytes versus several sequences of only a few bytes. ($1 \leq n \leq 256$)

Table 18. AC measurement conditions

Symbol	Parameter	Min.	Max.	Unit
C_L	Load capacitance	30		pF
—	Input rise and fall times	—	5	ns
—	Input pulse voltages	$0.2V_{CC}$ to $0.8V_{CC}$		V
—	Input timing reference voltages	$0.3V_{CC}$ to $0.7V_{CC}$		V
—	Output timing reference voltages	$V_{CC} / 2$		V

- Output Hi-Z is defined as the point where data out is no longer driven.

Figure 21. AC measurement I/O waveform

Table 19. AC characteristics (25 MHz operation, device grade 3, V_{CC} min = 2.7 V)

Identified with device belonging to X technology version; Test conditions specified in Table 10 and Table 18						
Symbol	Alt.	Parameter	Min.	Typ.	Max.	Unit
f_C	f_C	Clock frequency for the following instructions: FAST_READ, PP, SE, BE, DP, RES, WREN, WRDI, RDSR, WRSR	DC	—	25	MHz
f_R	—	Clock frequency for READ instructions	DC	—	20	MHz
$t_{CH}^{(1)}$	t_{CLH}	Clock High time	18	—	—	ns
$t_{CL}^{(1)}$	t_{CLL}	Clock Low time	18	—	—	ns
$t_{CLCH}^{(2)}$	—	Clock Rise time ⁽³⁾ (peak to peak)	0.1	—	—	V/ns
$t_{CHCL}^{(2)}$	—	Clock Fall time ⁽³⁾ (peak to peak)	0.1	—	—	V/ns
t_{SLCH}	t_{CSS}	\overline{S} Active Setup time (relative to C)	10	—	—	ns
t_{CHSL}	—	\overline{S} Not Active Hold time (relative to C)	10	—	—	ns
t_{DVCH}	t_{DSU}	Data In Setup time	5	—	—	ns
t_{CHDX}	t_{DH}	Data In Hold time	5	—	—	ns
t_{CHSH}	—	\overline{S} Active Hold time (relative to C)	10	—	—	ns
t_{SHCH}	—	\overline{S} Not Active Setup time (relative to C)	10	—	—	ns
t_{SHSL}	t_{CSH}	\overline{S} Deselect time	100	—	—	ns
$t_{SHQZ}^{(2)}$	t_{DIS}	Output Disable time	—	—	15	ns
t_{CLQV}	t_V	Clock Low to Output Valid	—	—	15	ns
t_{CLQX}	t_{HO}	Output Hold time	0	—	—	ns
t_{HLCH}	—	\overline{HOLD} Setup time (relative to C)	10	—	—	ns
t_{CHHH}	—	\overline{HOLD} Hold time (relative to C)	10	—	—	ns
t_{HHCH}	—	HOLD Setup time (relative to C)	10	—	—	ns
t_{CHHL}	—	HOLD Hold time (relative to C)	10	—	—	ns
$t_{HHQX}^{(2)}$	t_{LZ}	HOLD to Output Low-Z	—	—	15	ns
$t_{HLQZ}^{(2)}$	t_{HZ}	HOLD to Output High-Z	—	—	20	ns
$t_{WHSL}^{(4)}$	—	Write Protect Setup time	20	—	—	ns
$t_{SHWL}^{(4)}$	—	Write Protect Hold time	100	—	—	ns
$t_{DP}^{(2)}$	—	\overline{S} High to Deep Power-down mode	—	—	3	μ s
$t_{RES1}^{(2)}$	—	\overline{S} High to Standby Power mode without Electronic Signature Read	—	—	30	μ s
$t_{RES2}^{(2)}$	—	\overline{S} High to Standby Power mode with Electronic Signature Read	—	—	30	μ s

- $t_{CH} + t_{CL}$ must be greater than or equal to $1/f_C$
- Value guaranteed by characterization, not 100% tested in production.
- Expressed as a slew-rate.
- Only applicable as a constraint for a WRSR instruction when SRWD is set at 1.

Table 20. AC characteristics (50 MHz operation, device grade 6, V_{CC} min = 2.7 V)

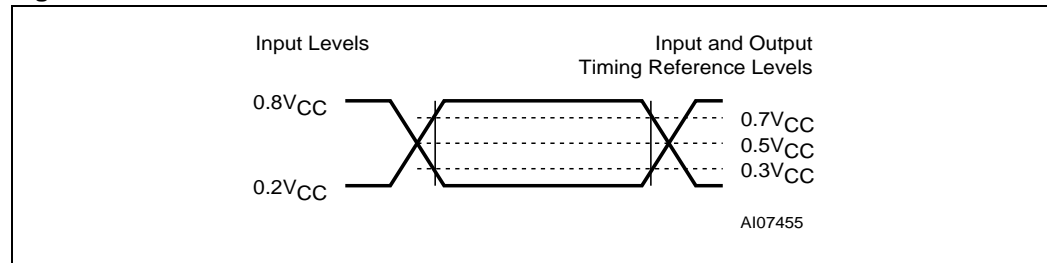
Test conditions specified in Table 10 and Table 18						
Symbol	Alt.	Parameter	Min.	Typ.	Max.	Unit
f_C	f_C	Clock frequency for the following instructions: FAST_READ, PP, SE, BE, DP, RES, WREN, RDID, WRDI, RDSR, WRSR	DC	—	50	MHz
f_R	—	Clock frequency for READ instructions	DC	—	25	MHz
$t_{CH}^{(1)}$	t_{CLH}	Clock High time	9	—	—	ns
$t_{CL}^{(1)}$	t_{CLL}	Clock Low time	9	—	—	ns
$t_{CLCH}^{(2)}$	—	Clock Rise time ⁽³⁾ (peak to peak)	0.1	—	—	V/ns
$t_{CHCL}^{(2)}$	—	Clock Fall time ⁽³⁾ (peak to peak)	0.1	—	—	V/ns
t_{SLCH}	t_{CSS}	\overline{S} Active Setup time (relative to C)	5	—	—	ns
t_{CHSL}	—	\overline{S} Not Active Hold time (relative to C)	5	—	—	ns
t_{DVCH}	t_{DSU}	Data In Setup time	2	—	—	ns
t_{CHDX}	t_{DH}	Data In Hold time	5	—	—	ns
t_{CHSH}	—	\overline{S} Active Hold time (relative to C)	5	—	—	ns
t_{SHCH}	—	\overline{S} Not Active Setup time (relative to C)	5	—	—	ns
t_{SHSL}	t_{CSH}	\overline{S} Deselect time	100	—	—	ns
$t_{SHQZ}^{(2)}$	t_{DIS}	Output Disable time	—	—	8	ns
t_{CLQV}	t_V	Clock Low to Output Valid	—	—	8	ns
t_{CLQX}	t_{HO}	Output Hold time	0	—	—	ns
t_{HLCH}	—	\overline{HOLD} Setup time (relative to C)	5	—	—	ns
t_{CHHH}	—	\overline{HOLD} Hold time (relative to C)	5	—	—	ns
t_{HHCH}	—	HOLD Setup time (relative to C)	5	—	—	ns
t_{CHHL}	—	HOLD Hold time (relative to C)	5	—	—	ns
$t_{HHQX}^{(2)}$	t_{LZ}	HOLD to Output Low-Z	—	—	8	ns
$t_{HLQZ}^{(2)}$	t_{HZ}	\overline{HOLD} to Output High-Z	—	—	8	ns
$t_{WHSL}^{(4)}$	—	Write Protect Setup time	20	—	—	ns
$t_{SHWL}^{(4)}$	—	Write Protect Hold time	100	—	—	ns
$t_{DP}^{(2)}$	—	\overline{S} High to Deep Power-down mode	—	—	3	μ s
$t_{RES1}^{(2)}$	—	\overline{S} High to Standby Power mode without Electronic Signature Read	—	—	30	μ s
$t_{RES2}^{(2)}$	—	\overline{S} High to Standby Power mode with Electronic Signature Read	—	—	30	μ s

- $t_{CH} + t_{CL}$ must be greater than or equal to $1/f_C$
- Value guaranteed by characterization, not 100% tested in production.
- Expressed as a slew-rate.
- Only applicable as a constraint for a WRSR instruction when SRWD is set at 1.

Table 21. AC characteristics (*40 MHz operation, device grade 6, V_{CC} min = 2.3 V)

Test conditions specified in Table 10 and Table 18						
Symbol	Alt.	Parameter	Min.	Typ.	Max.	Unit
f_C	f_C	Clock frequency for the following instructions: FAST_READ, PP, SE, BE, DP, RES, WREN, RDID, WRDI, RDSR, WRSR	DC	—	40	MHz
f_R	—	Clock frequency for READ instructions	DC	—	25	MHz
$t_{CH}^{(1)}$	t_{CLH}	Clock High time	11	—	—	ns
$t_{CL}^{(1)}$	t_{CLL}	Clock Low time	11	—	—	ns
$t_{CLCH}^{(2)}$	—	Clock Rise time ⁽³⁾ (peak to peak)	0.1	—	—	V/ns
$t_{CHCL}^{(2)}$	—	Clock Fall time ⁽³⁾ (peak to peak)	0.1	—	—	V/ns
t_{SLCH}	t_{CSS}	\overline{S} Active Setup time (relative to C)	5	—	—	ns
t_{CHSL}	—	\overline{S} Not Active Hold time (relative to C)	5	—	—	ns
t_{DVCH}	t_{DSU}	Data In Setup time	2	—	—	ns
t_{CHDX}	t_{DH}	Data In Hold time	5	—	—	ns
t_{CHSH}	—	\overline{S} Active Hold time (relative to C)	5	—	—	ns
t_{SHCH}	—	\overline{S} Not Active Setup time (relative to C)	5	—	—	ns
t_{SHSL}	t_{CSH}	\overline{S} Deselect time	100	—	—	ns
$t_{SHQZ}^{(2)}$	t_{DIS}	Output Disable time	—	—	8	ns
t_{CLQV}	t_V	Clock Low to Output Valid	—	—	8	ns
t_{CLQX}	t_{HO}	Output Hold time	0	—	—	ns
t_{HLCH}	—	\overline{HOLD} Setup time (relative to C)	5	—	—	ns
t_{CHHH}	—	\overline{HOLD} Hold time (relative to C)	5	—	—	ns
t_{HHCH}	—	HOLD Setup time (relative to C)	5	—	—	ns
t_{CHHL}	—	HOLD Hold time (relative to C)	5	—	—	ns
$t_{HHQX}^{(2)}$	t_{LZ}	HOLD to Output Low-Z	—	—	8	ns
$t_{HLQZ}^{(2)}$	t_{HZ}	\overline{HOLD} to Output High-Z	—	—	8	ns
$t_{WHSL}^{(4)}$	—	Write Protect Setup time	20	—	—	ns
$t_{SHWL}^{(4)}$	—	Write Protect Hold time	100	—	—	ns
$t_{DP}^{(2)}$	—	\overline{S} High to Deep Power-down mode	—	—	3	μ s
$t_{RES1}^{(2)}$	—	\overline{S} High to Standby Power mode without Electronic Signature Read	—	—	30	μ s
$t_{RES2}^{(2)}$	—	\overline{S} High to Standby Power mode with Electronic Signature Read	—	—	30	μ s

- $t_{CH} + t_{CL}$ must be greater than or equal to $1/f_C$
- Value guaranteed by characterization, not 100% tested in production.
- Expressed as a slew-rate.
- Only applicable as a constraint for a WRSR instruction when SRWD is set at 1.

Note: *40 MHz = max frequency device operation in extended Vcc range 2.3 to 2.7 V.

Table 22. AC characteristics, 75 MHz operation, VCC min = 2.7 V

Applies only to products made with 110 nm technology, identified with process digit '4' and process letter "B" in the part number ^{(1) (2)} Test conditions specified in Table 10 and Table 13						
Symbol	Alt.	Parameter	Min	Typ ⁽³⁾	Max	Unit
f _C	f _C	Clock frequency for the following instructions: FAST_READ, PP, SE, BE, DP, RES, WREN, WRDI, RDID, RDSR, WRSR	DC	—	75	MHz
f _R	—	Clock frequency for READ instructions	DC	—	33	MHz
t _{CH} ⁽⁴⁾	t _{CLH}	Clock High time	6	—		ns
t _{CL} ⁽³⁾	t _{CLL}	Clock Low time	6	—		ns
t _{CLCH} ⁽⁵⁾	—	Clock Rise time ⁽⁶⁾ (peak to peak)	0.1	—		V/ns
t _{CHCL} ⁽⁵⁾	—	Clock Fall time ⁽⁶⁾ (peak to peak)	0.1	—		V/ns
t _{SLCH}	t _{CSS}	\overline{S} Active Setup time (relative to C)	5	—		ns
t _{CHSL}	—	\overline{S} Not Active Hold time (relative to C)	5	—		ns
t _{DVCH}	t _{DSU}	Data In Setup time	2	—		ns
t _{CHDX}	t _{DH}	Data In Hold time	5	—		ns
t _{CHSH}	—	\overline{S} Active Hold time (relative to C)	5	—		ns
t _{SHCH}	—	\overline{S} Not Active Setup time (relative to C)	5	—		ns
t _{SHSL}	t _{CSH}	\overline{S} Deselect time	100	—		ns
t _{SHQZ} ⁽⁵⁾	t _{DIS}	Output Disable time	—	—	8	ns
t _{CLQV}	t _V	Clock Low to Output Valid under 30 pF/10 pF	—	—	8/6	ns
t _{CLQX}	t _{HO}	Output Hold time	0	—		ns
t _{HLCH}	—	\overline{HOLD} Setup time (relative to C)	5	—		ns
t _{CHHH}	—	\overline{HOLD} Hold time (relative to C)	5	—		ns
t _{HHCH}	—	\overline{HOLD} Setup time (relative to C)	5	—		ns
t _{CHHL}	—	\overline{HOLD} Hold time (relative to C)	5	—		ns
t _{HHQX} ⁽⁵⁾	t _{LZ}	\overline{HOLD} to Output Low-Z	—	—	8	ns
t _{HLQZ} ⁽⁵⁾	t _{HZ}	\overline{HOLD} to Output High-Z	—	—	8	ns
t _{WHSL} ⁽⁷⁾	—	Write Protect Setup time	20	—		ns
t _{SHWL} ⁽⁷⁾	—	Write Protect Hold time	100	—		ns
t _{DP} ⁽⁵⁾	—	\overline{S} High to Deep Power-down mode	—	—	3	μs
t _{RES1} ⁽⁵⁾	—	\overline{S} High to Standby mode without Read Electronic Signature	—	—	30	μs
t _{RES2} ⁽⁵⁾	—	\overline{S} High to Standby mode with Read Electronic Signature	—	—	30	μs

1. Details of how to find the technology process in the marking are given in AN1995, see also [Section 12: Ordering Information, Standard Parts](#).
2. 75 MHz operation is available only on the VCC range 2.7 V - 3.6 V; the maximum frequency in the extended Vcc range 2.3 V to 2.7 V is 40 MHz.
3. Typical values given for $T_A = 25\text{ }^\circ\text{C}$.
4. $t_{CH} + t_{CL}$ must be greater than or equal to $1/f_C$.
5. Value guaranteed by characterization, not 100% tested in production.
6. Expressed as a slew-rate.
7. Only applicable as a constraint for a WRSR instruction when SRWD is set at '1'.

Figure 22. Serial input timing

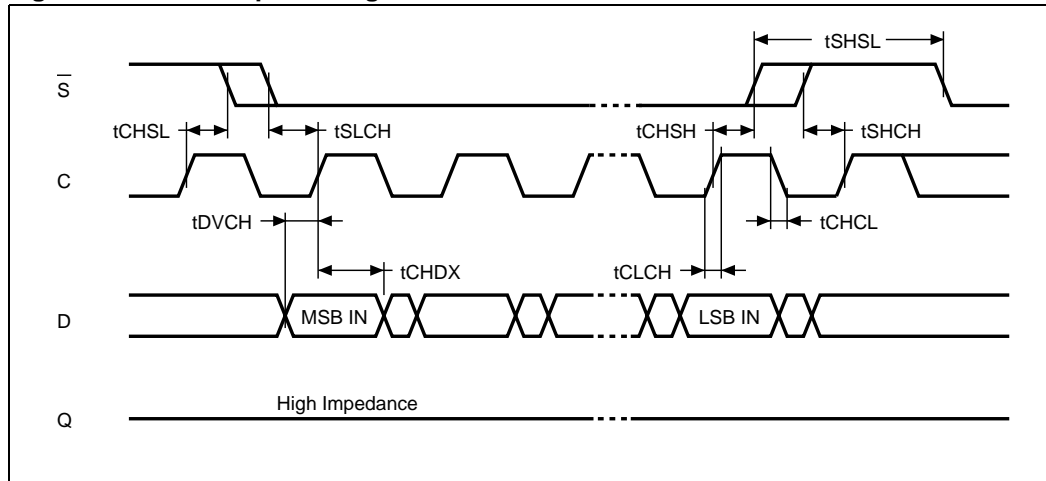
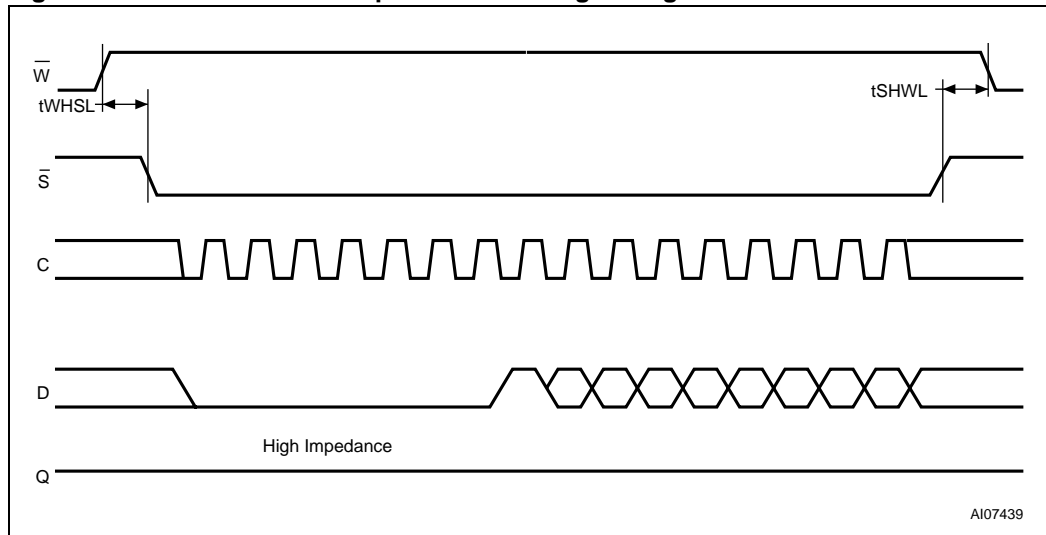

Figure 23. Write Protect setup and hold timing during WRSR when SRWD = 1



AI07439

Figure 24. Hold timing

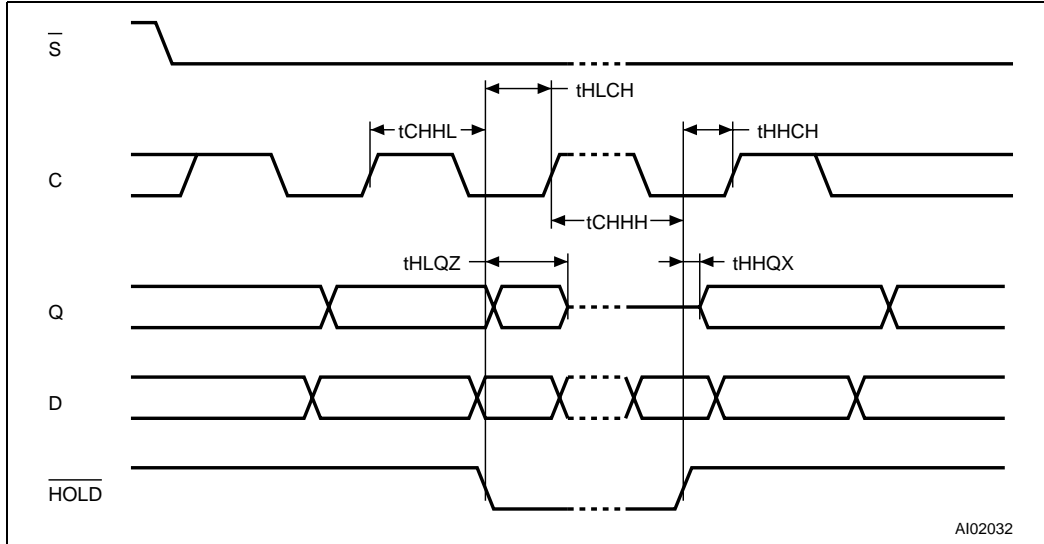
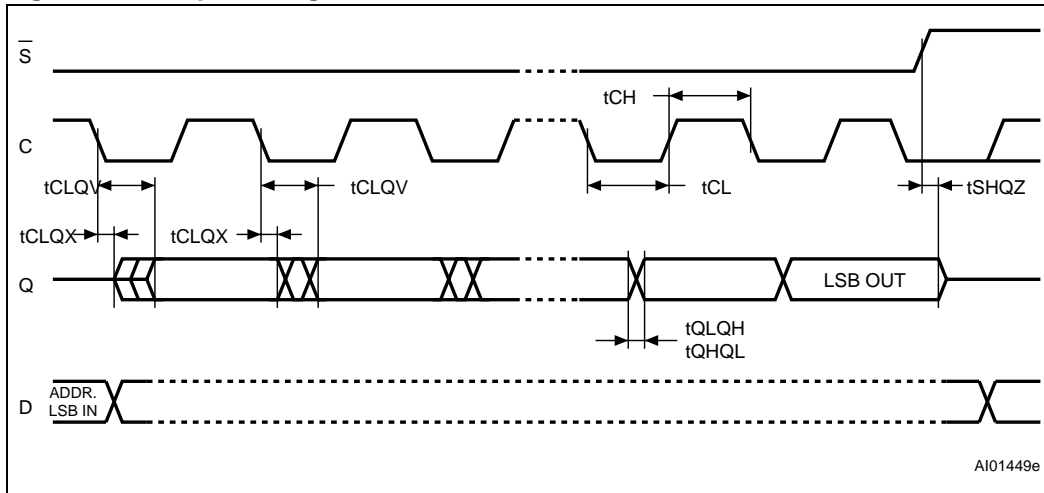

Figure 25. Output timing



11 Package mechanical

40 MHz is the maximum frequency for the devices operation in the extended Vcc range 2.3 V to 2.7 V.

Figure 26. SO8 narrow – 8 lead plastic Small Outline, 150 mils body width, package outline

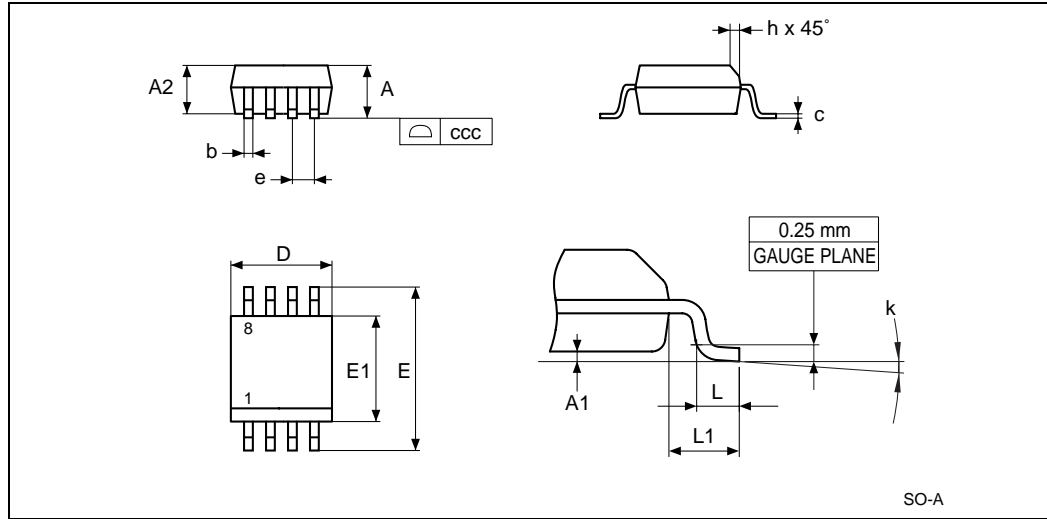

1. Drawing is not to scale.
2. The '1' that appears in the top view of the package shows the position of pin 1.

Table 23. SO8 narrow – 8 lead plastic Small Outline, 150 mils body width, package mechanical data

Symbol	millimeters			inches		
	Typ	Min	Max	Typ	Min	Max
A	—	—	1.75	—	—	0.069
A1	—	0.10	0.25	—	0.004	0.010
A2	—	1.25	—	—	0.049	—
b	—	0.28	0.48	—	0.011	0.019
c	—	0.17	0.23	—	0.007	0.009
ccc	—	—	0.10	—	—	0.004
D	4.90	4.80	5.00	0.193	0.189	0.197
E	6.00	5.80	6.20	0.236	0.228	0.244
E1	3.90	3.80	4.00	0.154	0.150	0.157
e	1.27	—	—	0.050	—	—
h	—	0.25	0.50	—	0.010	0.020
k	—	0°	8°	—	0°	8°
L	—	0.40	1.27	—	0.016	0.050
L1	1.04	—	—	0.041	—	—

Figure 27. SO8W – 8 lead plastic small outline, 208 mils body width, package outline

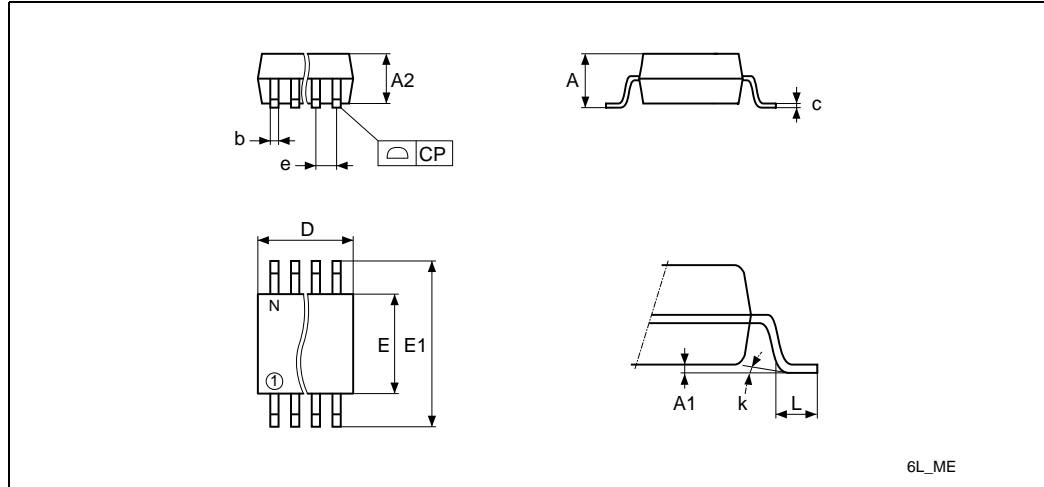

1. Drawing is not to scale.

Table 24. SO8 wide – 8 lead plastic small outline, 208 mils body width, package mechanical data

Symbol	millimeters			inches		
	Typ	Min	Max	Typ	Min	Max
A	—	—	2.50	—		0.098
A1	—	0.00	0.25	—	0.000	0.010
A2	—	1.51	2.00	—	0.059	0.079
b	0.40	0.35	0.51	0.016	0.014	0.020
c	0.20	0.10	0.35	0.008	0.004	0.014
CP	—	—	0.10	—	—	0.004
D	—	—	6.05	—	—	0.238
E	—	5.02	6.22	—	0.198	0.245
E1	—	7.62	8.89	—	0.300	0.350
e	1.27	—	—	0.050	—	—
k	—	0°	10°	—	0°	10°
L	—	0.50	0.80	—	0.020	0.031
N		8			8	

Figure 28. DFN8 (MLP8) 8-lead, dual flat package no lead, 6 x 5 mm, package outline

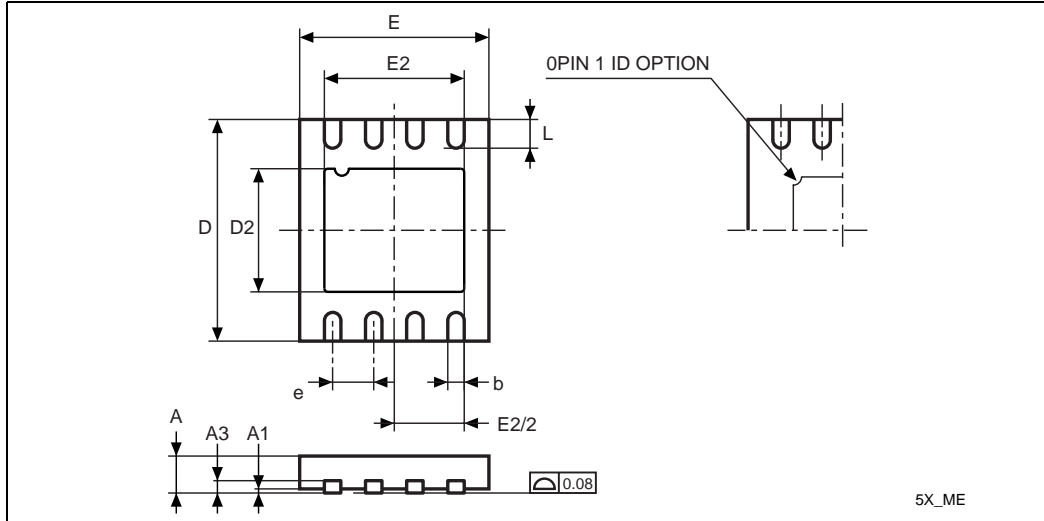

1. Drawing is not to scale.

Table 25. DFN8 (MLP8) 8-lead dual flat package no lead, 6 x 5 mm package mechanical data

Symbol	millimeters			inches		
	Typ	Min	Max	Typ	Min	Max
A	0.90	0.80	1.00	0.035	0.031	0.039
A1	0.02	0.00	0.05	0.001	0.000	0.002
A3	0.20	—	—	0.008	—	—
b	0.40	0.35	0.48	0.016	0.014	0.019
D	6.00	—	—	0.236	—	—
D2	3.00	2.80	3.20	0.118	0.110	0.126
E	5.00	—	—	0.197	—	—
E2	3.00	2.80	3.20	0.118	0.110	0.126
e	1.27	—	—	0.050	—	—
L	0.60	0.50	0.75	0.024	0.020	0.030

Figure 29. VFDFPN8 (MLP8) 8-lead Very thin Fine pitch Quad Flat Package No lead, 6 x 5 mm, package outline

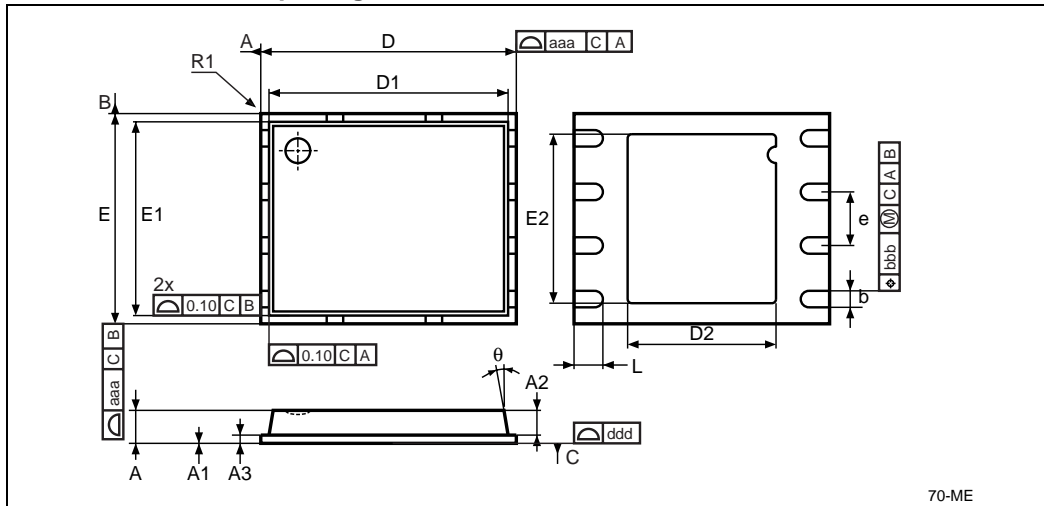

1. Drawing is not to scale.
2. The circle in the top view of the package indicates the position of pin 1.

Table 26. VFDFPN8 (MLP8) 8-lead Very thin Fine pitch Dual Flat Package No lead, 6 x 5 mm, package mechanical data

Symbol	millimeters			inches		
	Typ	Min	Max	Typ	Min	Max
A	0.85	0.80	1.00	0.0335	0.0315	0.0394
A1	—	0.00	0.05	—	0.0000	0.0020
A2	0.65	—	—	0.0256	—	—
A3	0.20	—	—	0.0079	—	—
b	0.40	0.35	0.48	0.0157	0.0138	0.0189
D	6.00	—	—	0.2362	—	—
D1	5.75	—	—	0.2264	—	—
D2	3.40	3.20	3.60	0.1339	0.1260	0.1417
E	5.00	—	—	0.1969	—	—
E1	4.75	—	—	0.1870	—	—
E2	4.00	3.80	4.30	0.1575	0.1496	0.1693
e	1.27	—	—	0.0500	—	—
R1	0.10	0.00	—	0.0039	0.0000	—
L	0.60	0.50	0.75	0.0236	0.0197	0.0295
Q	—	—	12°	—	—	12°
aaa	—	—	0.15	—	—	0.0059
bbb	—	—	0.10	—	—	0.0039
ddd	—	—	0.05	—	—	0.0020

Figure 30. UDFFPN8 (MLP8) 8-lead ultra thin fine pitch dual flat package no lead, 4 x 3 mm package mechanical data

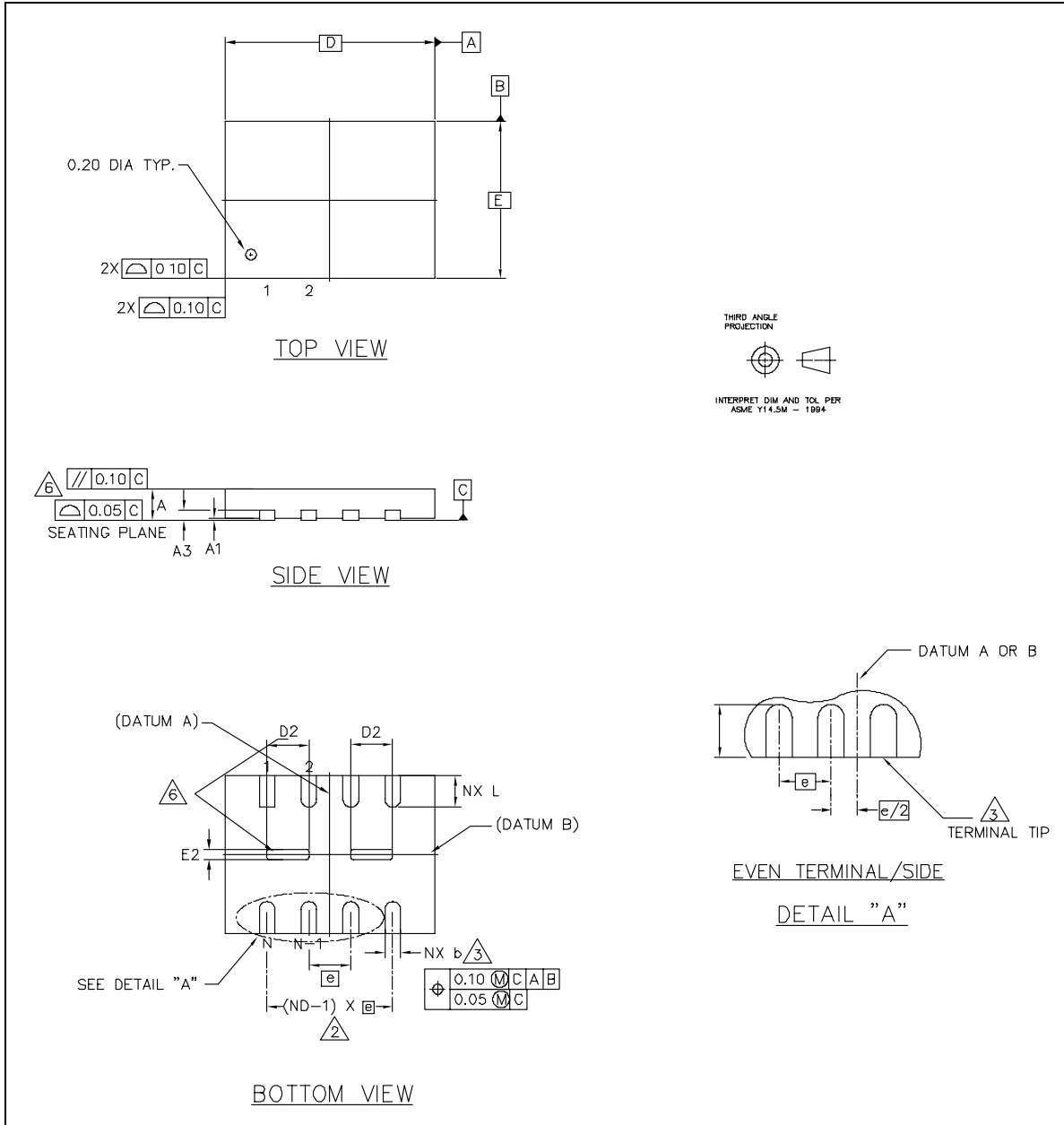
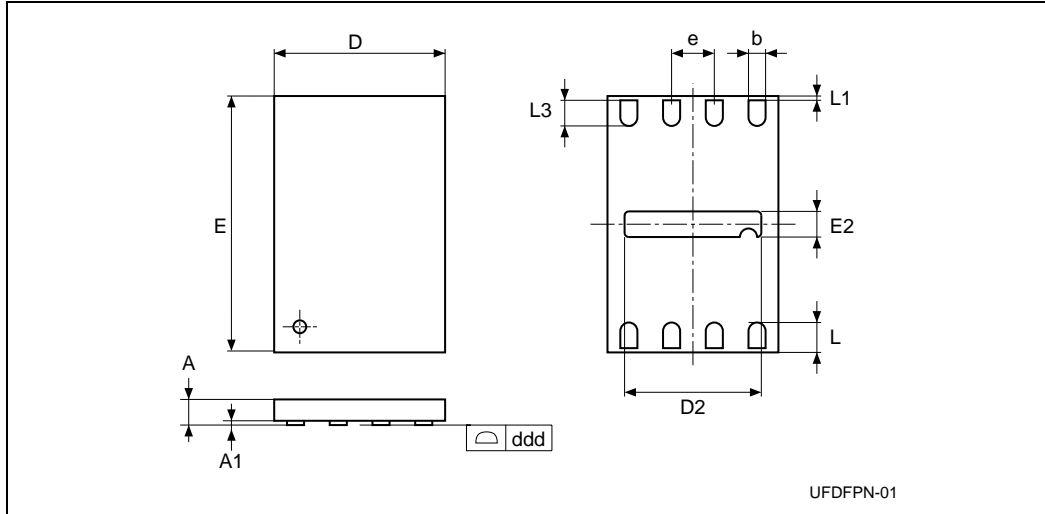

Table 27. UFDFPN8 (MLP8) 8-lead ultra thin fine pitch dual flat package no lead, 4 x 3 mm package mechanical data⁽¹⁾

Symbol	Databook (mm)			Drawing (mm)		
	Typ	Min	Max	Typ	Min	Max
A	0.55	0.45	0.60	0.55	0.45	0.60
A1	0.02	0.00	0.05	0.02	0.00	0.05
A3	—	0.127	0.15	—	0.127	0.15
θ	—	0°	12°	—	0°	12°
D2	0.80	0.70	0.90	0.80	0.70	0.90
E2	0.20	0.10	0.30	0.20	0.10	0.30
e	0.80	—	—	0.80	—	—
N ⁽²⁾	8	—	—	8	—	—
ND ⁽³⁾	4	—	—	4	—	—
b ⁽⁴⁾	0.30	0.25	0.35	0.30	0.25	0.35
L	0.60	0.55	0.65	0.60	0.55	0.65
D	4.00	3.90	4.10	4.00	3.90	4.10
E	3.00	2.90	3.10	3.00	2.90	3.10

1. Maximum package warpage is 0.05 mm; maximum allowable burrs is 0.076 mm in all directions; and bilateral coplanarity zone applies to the exposed heat sink slug as well as to the terminals; N is the total number of terminals.
2. N is the total number of terminals.
3. ND refers to the number of terminals on D side.
4. Dimension b applies to metallized terminal and is measured between 0.15 and 0.30 mm from terminal tip. if the terminal has the optional radius on the other end of the terminal, The dimension b should not be measured in that radius area.

Figure 31. UFDFPN8 (MLP8) 8-lead ultra thin fine pitch dual flat package no lead, 2 x 3 mm package outline



1. Drawing is not to scale.

Table 28. UFDFPN8 (MLP8) 8-lead ultra thin fine pitch dual flat package no lead, 2 x 3 mm package mechanical data

Symbol	millimeters			inches		
	Typ	Min	Max	Typ	Min	Max
A	0.55	0.45	0.60	0.022	0.018	0.024
A1	0.02	0.00	0.05	0.001	0.000	0.002
b ⁽¹⁾	0.25	0.20	0.30	0.010	0.008	0.012
D	2.00	1.90	2.10	0.079	0.075	0.083
D2	1.60	1.50	1.70	0.063	0.059	0.067
ddd ⁽²⁾	—	—	0.08	—	—	0.003
E	3.00	2.90	3.10	0.118	0.114	0.122
E2	0.20	0.10	0.30	0.008	0.004	0.012
e	0.50	—	—	0.020	—	—
L	0.45	0.40	0.50	0.018	0.016	0.020
L1	—	—	0.15	—	—	0.006
L3	—	0.30	—	—	0.012	—

1. Dimension b applies to plated terminal and is measured between 0.15 and 0.30 mm from the terminal tip.
2. Applied for exposed die paddle and terminals. Exclude embedding part of exposed die paddle from measuring.

12 Ordering Information, Standard Parts

Table 29. Ordering information scheme

	Example: M25P40	-	V	MN	6	T	P	B	A
Device Type	M25P = Serial Flash memory for code storage								
Device Function	40 = 4 Mbit (512 K x 8)								
Security features⁽¹⁾	- = no extra security S = CFD programmed with UID								
Operating Voltage	V = V _{CC} = 2.3 V to 3.6 V								
Package⁽²⁾	MN = SO8N (150 mil width) MP = VFDFPN8 6 x 5 mm (MLP8) MW = SO8W (208 mils width) MS = DFN8 (MLP8) ⁽²⁾ , 6 x 5 mm MB = UFDFPN8 (MLP8), 2 x 3 mm MC = UFDFPN8 (MLP8), 4 x 3 mm								
Device grade	6 = Industrial temperature range, -40 to 85 °C. Device tested with standard test flow. 3 ⁽³⁾ = Automotive temperature range (-40 to 125 °C). Device tested with High Reliability Certified Flow. ⁽⁴⁾								
Option	blank = Standard Packing T = Tape and Reel Packing								
Plating technology	P or G = RoHS compliant								
Lithography⁽⁵⁾	/X = 150 nm technology /4 = 110 nm, Catania Diffusion Plant B = 110 nm, Fab 2 Diffusion Plant								
Automotive Grade	A ⁽⁴⁾ = Automotive part (-40 to 125 °C). Device tested with High Reliability Certified Flow ⁽³⁾								

- Secure options are available upon customer request.
- Exposed pad of 3 x 3 mm.
- Device grade 3 available in an SO8 RoHS compliant package.
- Numonyx strongly recommends the use of the Automotive Grade devices (Autograde 6 and grade 3) for use in an automotive environment. The High Reliability Certified Flow (HRCF) is described in the quality note QNEE9801. Please ask your nearest Numonyx sales office for a copy.
- The letter (/X) denotes the automotive grade 3 device in 150 nm technology. The 110 nm device lithography is denoted by the identification marking letter B. For more information on how to identify products by the Process Identification Letter, please refer to AN1995: Serial Flash Memory Device Marking or contact your nearest Numonyx Sales Office.

Note: For available options (speed, package, etc.) or for further information on this device, please contact your nearest Numonyx Sales Office. The category of second-Level Interconnect is marked on the package and on the inner box label, in compliance with JEDEC Standard

JESD97. The maximum ratings related to soldering conditions are also marked on the inner box label.

13 Ordering Information, Automotive Parts

Table 30. Ordering information scheme

Example:	M25P40	-	V	MN	6	T	P	BA
Device Type								
M25P = Serial Flash memory for code storage								
Device Function								
40 = 4 Mbit (512 Kbit x 8)								
Security features								
- = no extra security								
Operating Voltage								
V = V _{CC} = 2.3 V to 3.6 V								
Package								
MN = SO8N (150 mil width)								
Device grade								
6 = Industrial temperature range, -40 to 85 °C. Device tested with High Reliability Certified flow								
3 = Automotive temperature range (-40 to 125 °C) Device tested with High Reliability Certified Flow.								
Option								
blank = Standard Packing								
T = Tape and Reel Packing								
Plating technology								
P or G = RoHS compliant								
Lithography								
/X = 150 nm technology (not suggested for new design)								
B = 110 nm , Fab 2 Diffusion Plant								
Automotive Grade								
blank = Automotive -40 to 125 °C part								
A = Automotive -40 °C to 85 °C part (used ONLY in conjunction with Device Grade 6 to distinguish the Auto Tested Parts from the non Auto Tested parts).								

Note: Numonyx strongly recommends the use of the Automotive Grade devices (Auto Grade 6 and 3) in an automotive environment. The high reliability certified flow (HRCF) is described in the quality note QNEE9801. Please ask your Numonyx sales office for a copy.

14 Revision history

Table 31. Document revision history

Date	Revision	Changes
12-Apr-2001	1.0	Document written.
25-May-2001	1.1	Serial Paged Flash Memory renamed as Serial Flash Memory.
11-Sep-2001	1.2	Changes to text: Signal Description/Chip Select; Hold Condition/1st para; Protection modes; Release from Power-down and Read Electronic Signature (RES); Power-up. Repositioning of several tables and illustrations without changing their contents. Power-up timing illustration; SO8W package removed. Changes to tables: Abs Max Ratings/ V_{IO} ; DC Characteristics/ V_{IL} .
16-Jan-2002	1.3	FAST_READ instruction added. Document revised with new timings, V_{WI} , I_{CC3} and clock slew rate. Descriptions of Polling, Hold Condition, Page Programming, Release for Deep Power-down made more precise. Value of $t_{V(max)}$ modified.
12-Sep-2002	1.4	Clarification of descriptions of entering Standby Power mode from Deep Power-down mode, and of terminating an instruction sequence or data-out sequence. VFQFPN8 package (MLP8) added. Document promoted to Preliminary Data.
13-Dec-2002	1.5	Typical Page Program time improved. Deep Power-down current changed. Write Protect setup and hold times specified, for applications that switch Write Protect to exit the Hardware Protection mode immediately before a WRSR, and to enter the Hardware Protection mode again immediately after.
12-Jun-2003	1.6	Document promoted from Preliminary Data to full Datasheet.
24-Nov-2003	2.0	Table of contents, warning about exposed paddle on MLP8, and Pb-free options added. 40 MHz AC Characteristics table included as well as 25 MHz. $I_{CC3(max)}$, $t_{SE}(typ)$ and $t_{BE}(typ)$ values improved. Change of naming for VDFPN8 package.
12-Mar-2004	3.0	Automotive range added. Soldering temperature information clarified for RoHS compliant devices.
05-Aug-2004	4.0	Device grade information clarified. Data-retention measurement temperature corrected. Details of how to find the date of marking added.
03-Jan-2005	5.0	Small text changes. Notes 2 and 3 removed from Table 29: Ordering information scheme . End timing line of t_{SHQZ} modified in Figure 25: Output timing .
01-Aug-2005	6.0	Updated Page Program (PP) instructions in Page Programming , Page Program (PP) , Instruction times , process technology 110 nm .
24-Oct-2005	7.0	50 MHz operation added (see Table 20: AC characteristics (50 MHz operation, device grade 6, VCC min = 2.7 V)). All packages are RoHS compliant. Blank option removed from under Plating technology in Table 29: Ordering information scheme . MLP package renamed as VFQFPN, silhouette and package mechanical drawing updated (see on page 1 and Figure 29: VFDFPN8 (MLP8) 8-lead Very thin Fine pitch Quad Flat Package No lead, 6 x 5 mm, package outline).

Table 31. Document revision history (continued)

Date	Revision	Changes
22-Dec-2005	8.0	Note 2 added below Figure 26 and note 3 added below Figure 29 t_{RES1} and t_{RES2} modified in Table 20: AC characteristics (50 MHz operation, device grade 6, VCC min = 2.7 V) . Read Identification (RDID) added. Titles of Figure 29 and Table 26 corrected.
14-Apr-2006	9	The data contained in Table 12 and Table 19 is no longer preliminary data. Figure 3: Bus Master and memory devices on the SPI bus modified and Note 2 added. 40 MHz frequency condition modified for I_{CC3} in Table 15: DC characteristics (device grade 3) . Condition changed for the Data Retention parameter in Table 12: Data retention and endurance . V_{WI} parameter for device grade 3 added to Table 8: Power-up timing and VWI threshold . SO8 package specifications updated (see Figure 26 and Table 23). /X process added to Table 29: Ordering information scheme .
05-Jun-2006	10	t_{RES1} and t_{RES2} parameter timings changed for devices produced with the "X" process technology in Table 19 and Table 19 . SO8 Narrow package specifications updated (see Figure 26 and Table 23).
18-Dec-2006	11	Hardware Write Protection feature added on page 1 . Small text changes. Section 2.7: VCC supply voltage and Section 2.8: VSS ground added. Figure 3: Bus Master and memory devices on the SPI bus modified, note 2 removed and replaced by explanatory paragraph. WIP bit behavior specified at Power-up in Section 7: Power-up and Power-down . T_{LEAD} added to Table 9: Absolute maximum ratings and V_{IO} max modified. VFQFPN8 package specifications updated (see Table 26 and Figure 29).
25-Jan-2007	12	V_{CC} voltage range from W17 2007 is extended to 2.3 V to 3.6 V. Table 21: AC characteristics (33 MHz operation, device grade 6, VCCmin =2.3 V) added. AC characteristics at 40 MHz removed.
15-May-2007	13	40 MHz operation added (see Table 21: AC characteristics (*40 MHz operation, device grade 6, VCC min = 2.3 V)). Removed the note below Table 10 . Removed "AC characteristics (33 MHz operation, device grade 6, VCCmin =2.3 V)" Table.
26-Jun-2007	14	Modified the note below Table 13 . Changed test condition for I_{CC3} in Table 14 . Changed clock frequency, from 20 to 25 MHz, in Table 20 and Table 21 .
10-Dec-2007	15	Added Numonyx Branding.
15-Oct-2008	16	Changed frequency up to 75 MHz (only in the standard Vcc range). Added new packages. Added UID/CFD protection. Extended Vcc range to 2.3 V.

Table 31. Document revision history (continued)

Date	Revision	Changes
18-February-2009	17	Revised the following: <ul style="list-style-type: none"> – Table 8: V_{wi} Min (Grade 3) = 1V vs. 2.1V or (remove one row & Grade indication) – Table 11: Erase/Program cycles = 100000 cycles also for Grade 3 (instead of 10000) – Table 13: I_{cc3} Operating Current (READ) ' change on section Test Condition OLD: C = 0.1V_{CC} / 0.9.V_{CC} at 40 MHz and 75 MHz, Q = open NEW: C = 0.1V_{CC} / 0.9.V_{CC} at 40 MHz, 50 MHz and 75 MHz, Q = open OLD: C = 0.1V_{CC} / 0.9.V_{CC} at 25 MHz, Q = open NEW: C = 0.1V_{CC} / 0.9.V_{CC} at 25 MHz and 33 MHz, Q = open – Table 14: I_{cc3} Operating Current (READ) ' change on section Test Condition OLD: C = 0.1V_{CC} / 0.9.V_{CC} at 25 MHz, Q = open NEW: C = 0.1V_{CC} / 0.9.V_{CC} at 25 MHz and 75 MHz, Q = open OLD: C = 0.1V_{CC} / 0.9.V_{CC} at 20 MHz, Q = open NEW: C = 0.1V_{CC} / 0.9.V_{CC} at 20 MHz and 33 MHz, Q = open – Table 15: this is valid also for grade 3: OLD: Instruction times, process technology 110 nm (device grade 6) NEW: Instruction times, process technology 110 nm – Table 16: this is valid also for grade 3: OLD: Instruction times, process technology 150 nm (device grade 6) NEW: Instruction times, process technology 150 nm – Table 17: with last 2 previous modifications it is possible to remove it – Table 19: Insert in heading: " identified with device belonging to X technology version;" Change t_{RES1} = 30 us & t_{RES2} = 30us (remove 3 us & 1.8 us & note 5)
14-May-2009	18	Revised cross references in Table 11.: Device grade and AC table correlation.
23-Feb-2010	19	Added the following package information: <ul style="list-style-type: none"> – Figure 30.: UFDFPN8 (MLP8) 8-lead ultra thin fine pitch dual flat package no lead, 4 x 3 mm package mechanical data – Figure 31.: UFDFPN8 (MLP8) 8-lead ultra thin fine pitch dual flat package no lead, 2 x 3 mm package outline
14-April-2010	20	Corrected package nomenclature.

Please Read Carefully:

INFORMATION IN THIS DOCUMENT IS PROVIDED IN CONNECTION WITH NUMONYX™ PRODUCTS. NO LICENSE, EXPRESS OR IMPLIED, BY ESTOPPEL OR OTHERWISE, TO ANY INTELLECTUAL PROPERTY RIGHTS IS GRANTED BY THIS DOCUMENT. EXCEPT AS PROVIDED IN NUMONYX'S TERMS AND CONDITIONS OF SALE FOR SUCH PRODUCTS, NUMONYX ASSUMES NO LIABILITY WHATSOEVER, AND NUMONYX DISCLAIMS ANY EXPRESS OR IMPLIED WARRANTY, RELATING TO SALE AND/OR USE OF NUMONYX PRODUCTS INCLUDING LIABILITY OR WARRANTIES RELATING TO FITNESS FOR A PARTICULAR PURPOSE, MERCHANTABILITY, OR INFRINGEMENT OF ANY PATENT, COPYRIGHT OR OTHER INTELLECTUAL PROPERTY RIGHT.

Numonyx products are not intended for use in medical, life saving, life sustaining, critical control or safety systems, or in nuclear facility applications.

Numonyx may make changes to specifications and product descriptions at any time, without notice.

Numonyx, B.V. may have patents or pending patent applications, trademarks, copyrights, or other intellectual property rights that relate to the presented subject matter. The furnishing of documents and other materials and information does not provide any license, express or implied, by estoppel or otherwise, to any such patents, trademarks, copyrights, or other intellectual property rights.

Designers must not rely on the absence or characteristics of any features or instructions marked "reserved" or "undefined." Numonyx reserves these for future definition and shall have no responsibility whatsoever for conflicts or incompatibilities arising from future changes to them.

Contact your local Numonyx sales office or your distributor to obtain the latest specifications and before placing your product order.

Copies of documents which have an order number and are referenced in this document, or other Numonyx literature may be obtained by visiting Numonyx's website at <http://www.numonyx.com>.

Numonyx StrataFlash® and Numonyx® Forté™ Serial Flash Memory are trademarks or registered trademarks of Numonyx or its subsidiaries in the United States and other countries.

*Other names and brands may be claimed as the property of others.

Copyright © 2009, Numonyx, B.V., All Rights Reserved.