

All information is subject to change without notice. Please read bottom notes.

- FEATURES:** (1) 8.4" XGA color display with High Brightness (320cd/m²).
 (2) Wide viewing angle and wide operating temperature.
 (3) Built in Long Life LEDs (MTBF:70,000 h).
 (Conditions / Ta:25°C, PWM=100%(continuing lighting))
 (4) Replaceable structure of LED units.
 (5) Mounting compatible with LTM08C351 series and LTA084C270F.
 (6) Resistance type touch panel assemble(4 wire, Except controller)

TENTATIVE

RoHS compatible

MECHANICAL SPECIFICATIONS

| Item | Specifications |
|----------------------------|-------------------------------------|
| Dimensional Outline (Typ.) | 199.5 (W) x 149.5 (H) x 13.0 (D) mm |
| Number of Pixels | 1024 (W) x 768 (H) pixels |
| Active Area | 170.496 (W) x 127.872 (H) mm |
| Pixel Pitch | 0.1665 (W) x 0.1665 (H) |
| Weight (approximately) | (TBD) |
| Backlight | Sidelight (LEDs) |

ABSOLUTE MAXIMUM RATINGS

| Item | Min. | Max. | Unit | |
|--|---------------------|------|----------------------|---|
| Supply Voltage | (V _{DD}) | -0.3 | 4.0 | V |
| | (V _{LED}) | 0 | 20 | V |
| Input Signal Voltage | (V _{IN}) | -0.3 | V _{DD} +0.3 | V |
| Operating Temperature | -20 | 70 | °C | |
| Storage Temperature | -30 | 80 | °C | |
| Storage Humidity (Max. wet bulb temp. = 39°C) | 10 | 90 | %(RH) | |

ELECTRICAL SPECIFICATION (Ta=25°C) (RECOMMENDED OPERATION CONDITION)

| Item | Min. | Typ. | Max. | Unit | Remarks | |
|---------------------------------|----------------------------------|------|-------|-----------------|---------|----------|
| Supply Voltage | (V _{DD}) | 3.0 | 3.3 | 3.6 | V | |
| | (V _{LED}) | 10.8 | 12.0 | 13.2 | V | |
| Differential Input Voltage | (V _{ID}) | 0.25 | --- | 0.45 | V | |
| Common Mode Input Voltage | (V _{CM}) | 1.0 | 1.25 | 2.0 | V | |
| High Level Input Voltage | (V _{IH}) | 2.2 | --- | V _{DD} | V | REV |
| Low Level Input Voltage | (V _{IL}) | 0 | --- | 0.7 | V | REV |
| Backlight ON/OFF signal | (V _{ON/OFF}) | 2.0 | --- | V _{DD} | V | ON |
| | | 0 | --- | 0.8 | V | OFF |
| Luminance control signal | (V _{PWM}) | 0 | --- | 3.3 | V | |
| Current Consumption | (I _{DD}) ^{*1} | --- | (TBD) | --- | mA | |
| | (I _{LED}) | --- | (335) | --- | mA | PWM=100% |
| Power Consumption ^{*1} | | --- | (TBD) | --- | W | PWM=100% |

*1 : 8 color bars pattern

OPTICAL SPECIFICATION (Ta=25°C)

| Item | Min. | Typ. | Max. | Unit | Remarks |
|--|---------------------|-------|--------|------|----------------------------|
| Contrast Ratio | (CR) | (250) | (400) | --- | Without T/P |
| Viewing Angle (CR ≥ 10) | (Upper+Lower) | --- | 100 | --- | ° Without T/P |
| | (Left+Right) | --- | 120 | --- | ° Without T/P |
| Response Time | (t _{ON}) | --- | 8 | --- | ms |
| | (t _{OFF}) | --- | 17 | --- | ms |
| Luminance | (L) | (220) | 320 | --- | cd/m ² PWM=100% |
| Lamp Life Time (MTBF) ^{*2 *3} | | | 70,000 | | h PWM=100% |

*2 : Conditions ; Ta=25°C, continuous lighting

*3 : Definitions of failure ; 1) Lcd luminance becomes half of the minimum value. 2) LED doesn't light normally.

*The information contained herein is presented only as a guide for the applications of our products. No responsibility is assumed by Toshiba Matsushita Display Technology or other rights of the third parties which may result from its use. No license is granted by implication or otherwise under any patent or patent rights of Toshiba Matsushita Display Technology or others.

*The information contained herein may be changed without prior notice. It is therefore advisable to contact Toshiba Matsushita Display Technology before proceeding with the design of equipment incorporating this product.

<Touch Panel Condition>

Recommended Operating Conditions

| Item | | Min. | Typ. | Max. | Unit | Remarks |
|----------------|----------|------|------|------|------|---------|
| Supply Voltage | V_{TP} | --- | 5.0 | 7.0 | V | |

Electrical Specifications

| Item | | Min. | Typ. | Max. | Unit | Remarks | |
|------------------------------|------------|-------|------|------|------|---------|--|
| Insulation Resistance | Z | 20 | --- | --- | MOhm | DC25V | |
| Resistance between Terminals | #1 - #3(X) | R_x | 200 | --- | 1500 | Ohm | Measured at connector pin(including conductor resistance). |
| | #2 - #4(Y) | R_y | 100 | --- | 600 | | |
| Linearity | - | | | 1.5 | % | | |
| Chattering | - | | | 10 | msec | | |

Mechanical Specifications

| Item | | Min. | Typ. | Max. | Unit | Remarks |
|--------------------------|--|------|------|------|------|---------|
| Operating Starting Force | | 5 | --- | 50 | gf | |
| Surface Hardness | | 3 | | | H | |

DIMENSIONAL OUTLINE

<Front side>

TENTATIVE

Unit : mm

Standard tolerance : +/-0.5

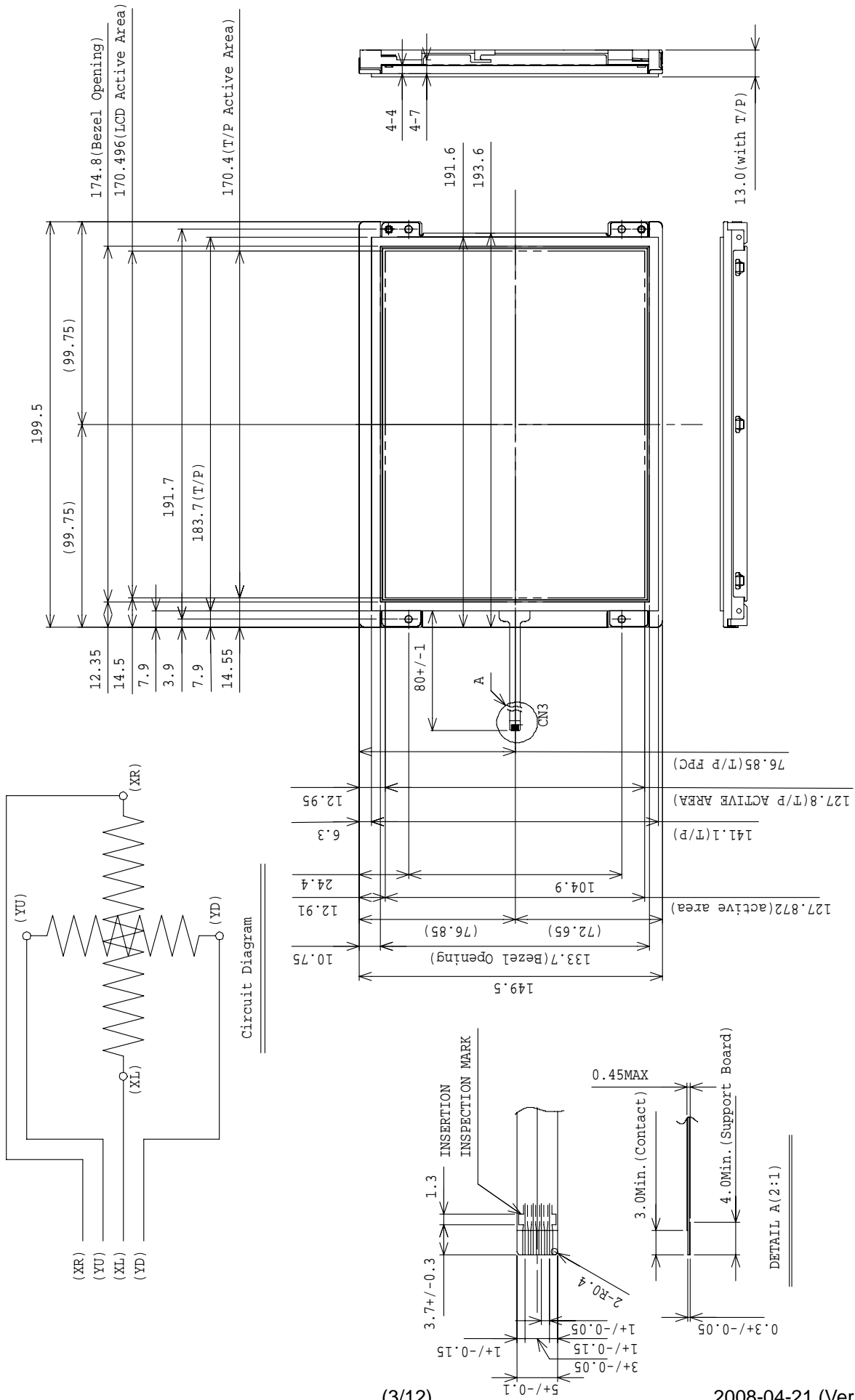

<Rear side>

TENTATIVE

Unit : mm

Standard tolerance : +/-0.5

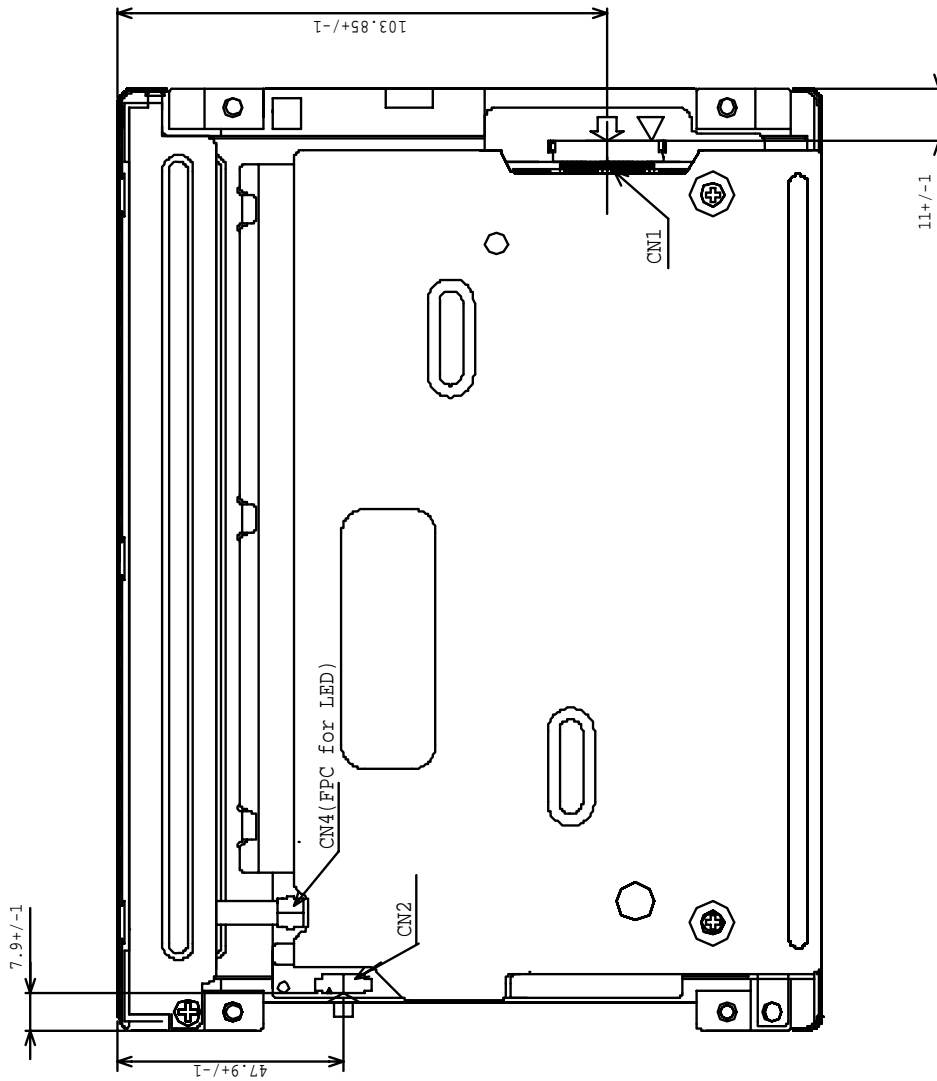

BLOCK DIAGRAM

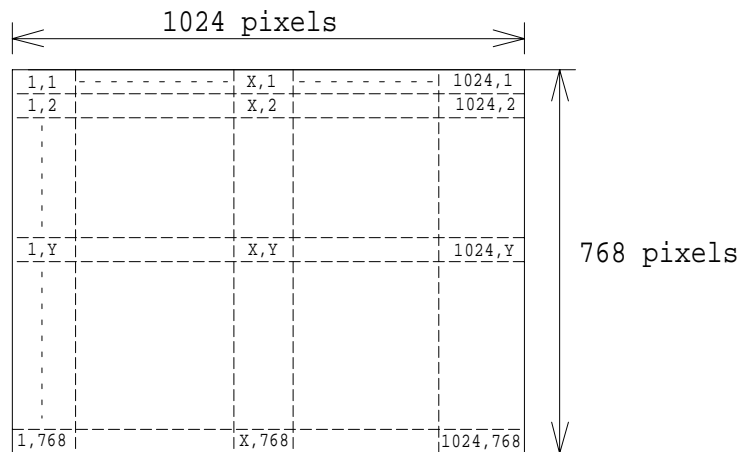
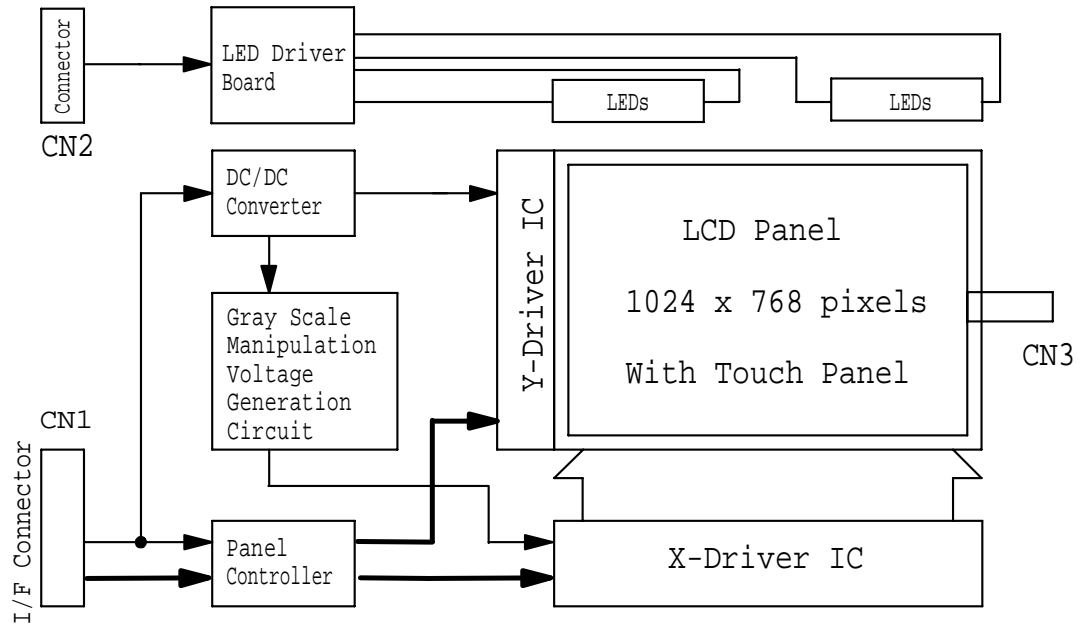

SEQUENCE OF POWER SUPPLIES AND SIGNALS

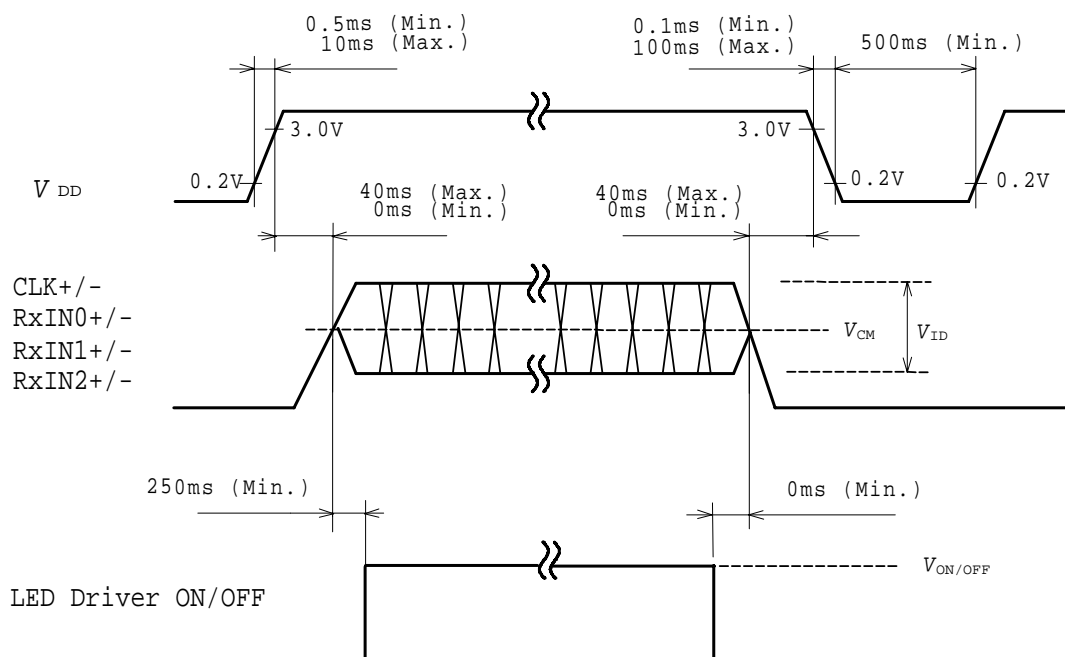

Note 1) When turn V_{DD} on and turn it off, the form of voltage should be input with no ripple signal.

TIMING CHART

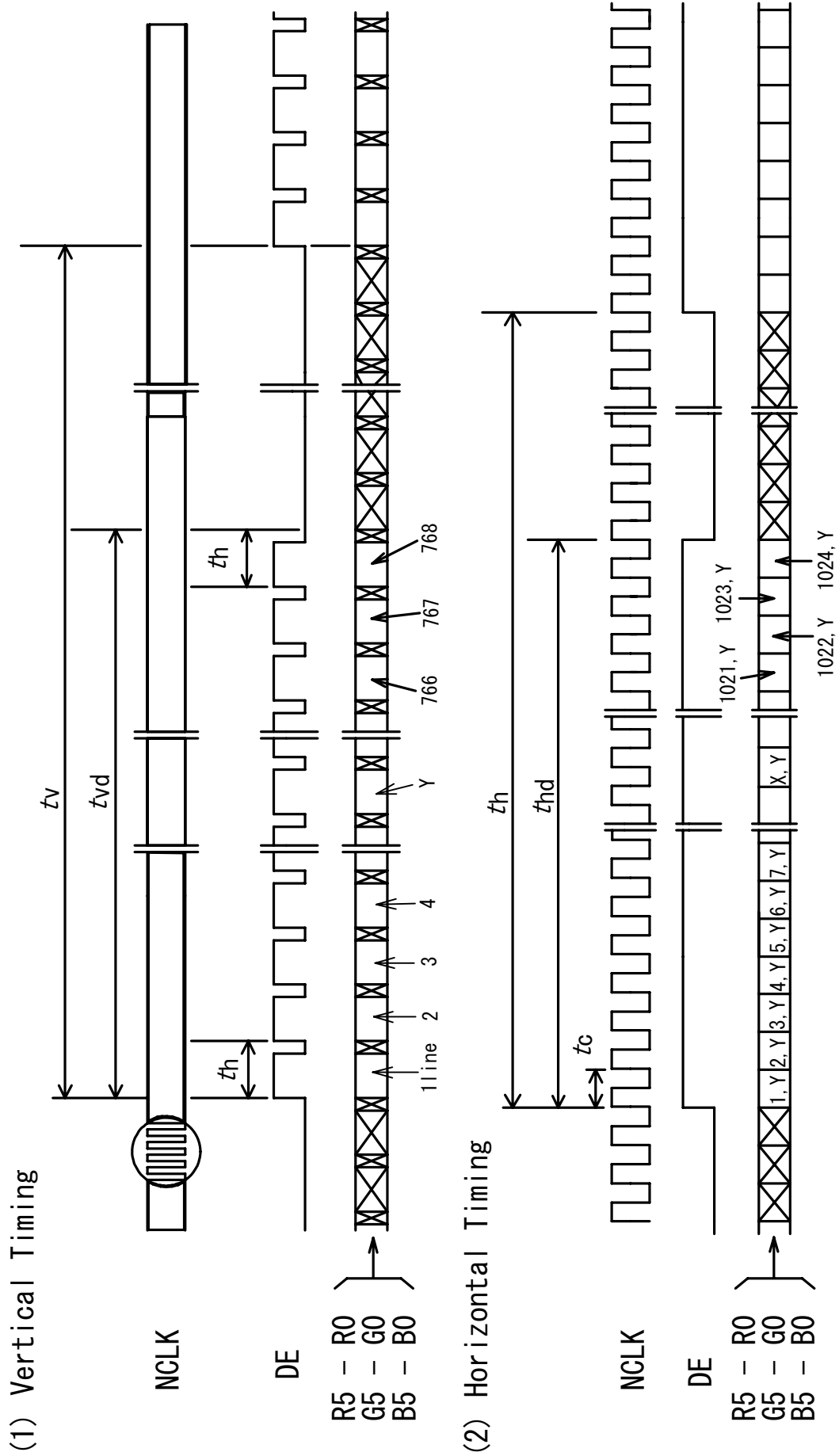

TIMING SPECIFICATION *1 *2 *3 *4 *5 *6

| Item | Symbol | Min. | Typ. | Max. | Unit | Remarks |
|-------------------------|----------|-----------------------|-----------------------|----------------------|------|---------|
| Frame Period | t_v | 778 x t_h | 806 x t_h 16.66 | 860 x t_h 17.86 | --- | ms |
| Vertical Display Term | t_{vd} | 768 x t_h | 768 x t_h | 768 x t_h | --- | |
| One Line Scanning Time | t_h | 1334 x t_c 20.52 | 1344 x t_c 20.68 | 1462 x t_c --- | --- | μ s |
| Horizontal Display Term | t_{hd} | 1024 x t_c | 1024 x t_c | 1025 x t_c | --- | |
| Clock Period | t_c | 15.0 | 15.384 | --- | --- | ns |

Note 1) Refer to "TIMING CHART" and LVDS (THC63LVDF84A-85) specifications by THine Electronics, Inc.

Note 2) If ENAB is fixed to "H" or "L" level for certain period while NCLK is supplied, the panel displays black with some flicker.

Note 3) Don't fix NCLK to "H" or "L" level while the VDD is supplied.

If NCLK is fixed to "H" or "L" level for certain period while ENAB is supplied, the panel may be damaged.

When it holds on, DC voltage supplies to liquid crystal materials and it may cause damage to liquid crystal materials.

Note 4) Please adjust LCD operating signal timing and LED PWM frequency, to optimize the display quality.

There is a possibility that flicker is observed by the interference of LCD operating signal timing and PWM condition (especially driving frequency), even if the condition satisfies above timing specifications and recommended operating conditions shown on page 1.

Note 5) Do not make t_v , t_{vd} and t_h fluctuate.

If t_v , t_{vd} and t_h are fluctuate, the panel displays black.

Note 6) Keep constant the number of clock within one line scanning time and the number of scanning line within one frame period.

CONNECTOR PIN ASSIGNMENT FOR INTERFACE**CN1 INPUT SIGNAL**

Connector : 20268-020E-03F / I-PEX CO., LTD.

Mating Connector : 20230-020B-F or 20230-T20-F or 20230-W20B-F / I-PEX CO.,LTD.

DF19G-20S-1C(Plug), DF19A-2830SCFA(Crimp contact) / HIROSE ELECTRIC CO., LTD.

| Terminal No. | Symbol | Function |
|--------------|----------------------|--|
| 1 | V _{DD} | +3.3V POWER SUPPLY |
| 2 | V _{DD} | +3.3V POWER SUPPLY |
| 3 | GND* ¹ | |
| 4 | GND* ¹ | |
| 5 | RxIN0- | Negative LVDS differential data input (R0-R5, G0) * ³ |
| 6 | RxIN0+ | Positive LVDS differential data input (R0-R5, G0) * ³ |
| 7 | GND* ¹ | |
| 8 | RxIN1- | Negative LVDS differential data input (G1-G5, B0-B1) * ³ |
| 9 | RxIN1+ | Positive LVDS differential data input (G1-G5, B0-B1) * ³ |
| 10 | GND* ¹ | |
| 11 | RxIN2- | Negative LVDS differential data input (B2-B5, NC, NC, DE) * ³ |
| 12 | RxIN2+ | Positive LVDS differential data input (B2-B5, NC, NC, DE) * ³ |
| 13 | GND* ¹ | |
| 14 | CLK- | Clock Signal (-) |
| 15 | CLK+ | Clock Signal (+) |
| 16 | CLK _{EDID} | DDC clock |
| 17 | REV | Display Reverse("L" level or Open : Normal, "H" level : Reverse) |
| 18 | NC* ² | Non Connection (open) |
| 19 | NC* ² | Non Connection (open) |
| 20 | DATA _{EDID} | DDC data |

Note 1) Please connect GND pin to ground. Don't use it as no-connect nor connection with high impedance.

Note 2) Please connect NC pin to nothing. Don't connect it to ground nor to other signal input.

Note 3) Refer to next page.

CN2 LED INPUT SIGNAL

Connector : 53261-0671 / MOLEX Inc.

Mating Connector : 51021-0600 / MOLEX Inc.

| Terminal No. | Symbol | Function |
|--------------|--------|-------------------------------------|
| 1 | VLED | Power Supply : +12V |
| 2 | VLED | Power Supply : +12V |
| 3 | VSS | GND |
| 4 | VSS | GND |
| 5 | ON/OFF | "H(+3.3V)":ON, "L(GND or Open)":OFF |
| 6 | PWM | 1-100%(200Hz) |

CN3 TOUCH PANEL

FPC: 1.0mm pitch, Gold plating

Mating connector: FC1S004HA1 / JAE

| Terminal No. | Symbol | Function |
|--------------|--------|-------------------------|
| 1 | XR | Touch Panel XR Terminal |
| 2 | YU | Touch Panel YU Terminal |
| 3 | XL | Touch Panel XL Terminal |
| 4 | YD | Touch Panel YD Terminal |

**RECOMMENDED TRANSMITTER (THC63LVDF63A, THC63LVDM63A by Thine Electronics, Inc.)
TO LT084AC37100 INTERFACE ASSIGNMENT**

Case1: 6bit Transmitter

| THC63LVDF63A, THC63LVDM63A | | | | LT084AC37100 Interface (CN1) | | |
|----------------------------|----------|--|---------------------------------|------------------------------|----------------|------------------|
| Input Terminal No. | | Input Signal (Graphics controller output signal) | | Output Signal Symbol | Terminal | Symbol |
| Symbol | Terminal | Symbol | Function | | | |
| TA0 | 44 | R0 | Red Pixels Display Data (LSB) | TA- TA+ | No.5 No.6 | RxIN0- RxIN0+ |
| TA1 | 45 | R1 | Red Pixels Display Data | | | |
| TA2 | 47 | R2 | Red Pixels Display Data | | | |
| TA3 | 48 | R3 | Red Pixels Display Data | | | |
| TA4 | 1 | R4 | Red Pixels Display Data | | | |
| TA5 | 3 | R5 | Red Pixels Display Data (MSB) | | | |
| TA6 | 4 | G0 | Green Pixels Display Data (LSB) | | | |
| TB0 | 6 | G1 | Green Pixels Display Data | TB- TB+ | No.8 No.9 | RxIN1- RxIN1+ |
| TB1 | 7 | G2 | Green Pixels Display Data | | | |
| TB2 | 9 | G3 | Green Pixels Display Data | | | |
| TB3 | 10 | G4 | Green Pixels Display Data | | | |
| TB4 | 12 | G5 | Green Pixels Display Data (MSB) | | | |
| TB5 | 13 | B0 | Blue Pixels Display Data (LSB) | | | |
| TB6 | 15 | B1 | Blue Pixels Display Data | | | |
| TC0 | 16 | B2 | Blue Pixels Display Data | TC- TC+ | No.11 No.12 | RxIN2- RxIN2+ |
| TC1 | 18 | B3 | Blue Pixels Display Data | | | |
| TC2 | 19 | B4 | Blue Pixels Display Data | | | |
| TC3 | 20 | B5 | Blue Pixels Display Data (MSB) | | | |
| TC4 | 22 | NC* ¹ | Non Connection (open) | | | |
| TC5 | 23 | NC* ¹ | Non Connection (open) | | | |
| TC6 | 25 | DE | Compound Synchronization Signal | | | |
| CLK IN | 26 | NCLK | Data Sampling Clock | TCLK- TCLK+ | No.14 No.15 | CLK- CLK+ |

Note 1) Please connect NC pin to nothing. Don't connect it to ground nor to other signal input.

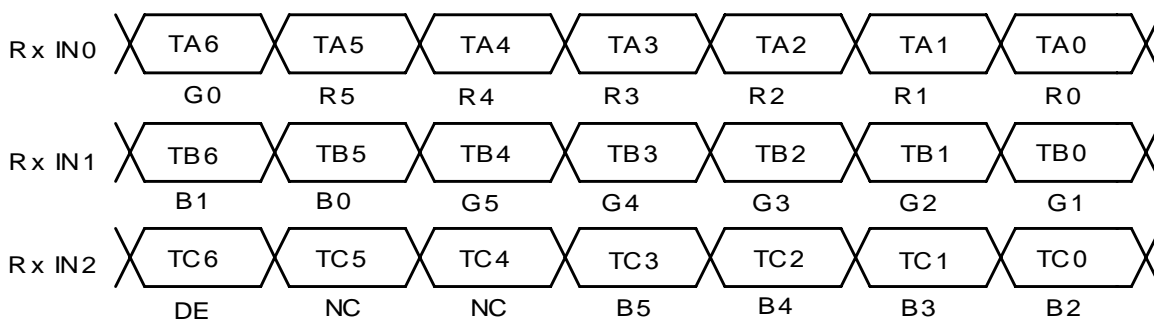

**RECOMMENDED TRANSMITTER (THC63LVDF83A, THC63LVDM83A, THC63LVDM83A-855)
TO LT084AC37100 INTERFACE ASSIGNMENT**

Case2: 8bit Transmitter

| THC63LVDF83A, THC63LVDM83A, THC63LVDM83A-855 | | | | LT084AC37100 Interface (CN1) | | |
|--|----------|--|---------------------------------|------------------------------|----------------|------------------|
| Input Terminal No. | | Input Signal (Graphics controller output signal) | | Output Signal Symbol | | |
| Symbol | Terminal | Symbol | Function | | Terminal | Symbol |
| TA0 | 51 | R0 | Red Pixels Display Data (LSB) | TA- TA+ | No.5 No.6 | RxIN0- RxIN0+ |
| TA1 | 52 | R1 | Red Pixels Display Data | | | |
| TA2 | 54 | R2 | Red Pixels Display Data | | | |
| TA3 | 55 | R3 | Red Pixels Display Data | | | |
| TA4 | 56 | R4 | Red Pixels Display Data | | | |
| TA5 | 3 | R5 | Red Pixels Display Data (MSB) | | | |
| TA6 | 4 | G0 | Green Pixels Display Data (LSB) | | | |
| TB0 | 6 | G1 | Green Pixels Display Data | TB- TB+ | No.8 No.9 | RxIN1- RxIN1+ |
| TB1 | 7 | G2 | Green Pixels Display Data | | | |
| TB2 | 11 | G3 | Green Pixels Display Data | | | |
| TB3 | 12 | G4 | Green Pixels Display Data | | | |
| TB4 | 14 | G5 | Green Pixels Display Data (MSB) | | | |
| TB5 | 15 | B0 | Blue Pixels Display Data (LSB) | | | |
| TB6 | 19 | B1 | Blue Pixels Display Data | | | |
| TC0 | 20 | B2 | Blue Pixels Display Data | TC- TC+ | No.11 No.12 | RxIN2- RxIN2+ |
| TC1 | 22 | B3 | Blue Pixels Display Data | | | |
| TC2 | 23 | B4 | Blue Pixels Display Data | | | |
| TC3 | 24 | B5 | Blue Pixels Display Data (MSB) | | | |
| TC4 | 27 | NC ^{*1} | Non Connection (open) | | | |
| TC5 | 28 | NC ^{*1} | Non Connection (open) | | | |
| TC6 | 30 | DE | Compound Synchronization Signal | | | |
| TD0 | 50 | NC ^{*1} | Non Connection (open) | TD- TD+ | | |
| TD1 | 2 | NC ^{*1} | Non Connection (open) | | | |
| TD2 | 8 | NC ^{*1} | Non Connection (open) | | | |
| TD3 | 10 | NC ^{*1} | Non Connection (open) | | | |
| TD4 | 16 | NC ^{*1} | Non Connection (open) | | | |
| TD5 | 18 | NC ^{*1} | Non Connection (open) | | | |
| TD6 | 25 | NC ^{*1} | Non Connection (open) | | | |
| CLK IN | 31 | NCLK | Data Sampling Clock | TCLK- TCLK+ | No.14 No.15 | CLK- CLK+ |

Note 1) Please connect NC pin to nothing. Don't connect it to ground nor to other signal input.

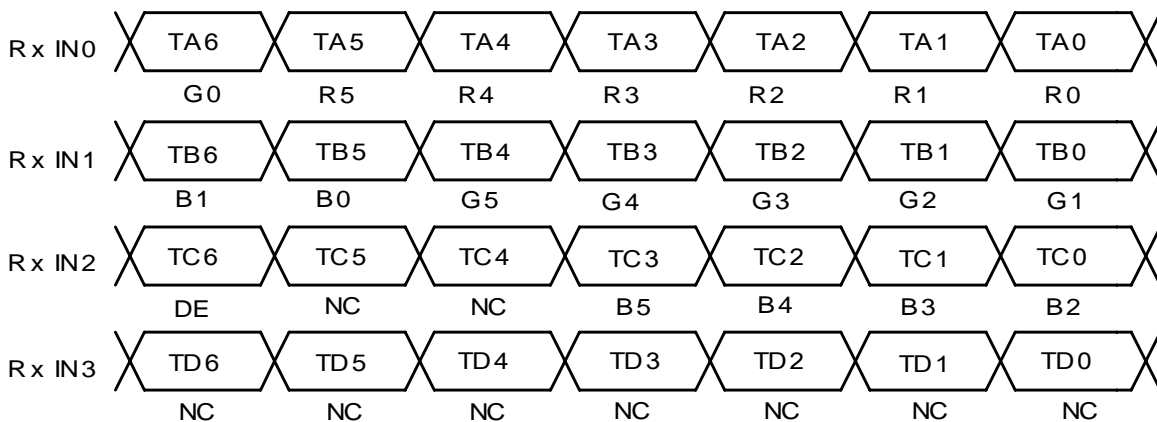

256k (k=1024) COLORS COMBINATION TABLE

| | Display | R5 R4 R3 R2 R1 R0 | G5 G4 G3 G2 G1 G0 | B5 B4 B3 B2 B1 B0 | Gray Scale Level |
|-------------------------|-----------------------------|-------------------|-------------------|-------------------|------------------|
| Basic Color | Black | L L L L L L L | L L L L L L L | L L L L L L L | --- |
| | Blue | L L L L L L L | L L L L L L L | H H H H H H H | --- |
| | Green | L L L L L L L | H H H H H H H | L L L L L L L | --- |
| | Light Blue | L L L L L L L | H H H H H H H | H H H H H H H | --- |
| | Red | H H H H H H H | L L L L L L L | L L L L L L L | --- |
| | Purple | H H H H H H H | L L L L L L L | H H H H H H H | --- |
| | Yellow | H H H H H H H | H H H H H H H | L L L L L L L | --- |
| | White | H H H H H H H | H H H H H H H | H H H H H H H | --- |
| Gray Scale of Red | Black | L L L L L L L | L L L L L L L | L L L L L L L | L 0 |
| | Dark ↑ ↓ Light | L L L L L L H | L L L L L L L | L L L L L L L | L 1 |
| | | L L L L L H L | L L L L L L L | L L L L L L L | L 2 |
| | | : : : | : : : | : : : | L3... L60 |
| | | H H H H L L H | L L L L L L L | L L L L L L L | L61 |
| | H H H H H L L | L L L L L L L | L L L L L L L | L62 | |
| | Red | H H H H H H H | L L L L L L L | L L L L L L L | Red L63 |
| | Gray Scale of Green | Black | L L L L L L L | L L L L L L L | L L L L L L L |
| Dark ↑ ↓ Light | | L L L L L L L | L L L L L L H | L L L L L L L | L 1 |
| | | L L L L L L L | L L L L L H L | L L L L L L L | L 2 |
| | | : : : | : : : | : : : | L3... L60 |
| | | L L L L L L L | H H H H L L H | L L L L L L L | L61 |
| L L L L L L L | | H H H H H L L | L L L L L L L | L62 | |
| Green | | L L L L L L L | H H H H H H H | L L L L L L L | Green L63 |
| Gray Scale of Blue | | Black | L L L L L L L | L L L L L L L | L L L L L L L |
| | Dark ↑ ↓ Light | L L L L L L L | L L L L L L L | L L L L L L H | L 1 |
| | | L L L L L L L | L L L L L L L | L L L L L H L | L 2 |
| | | : : : | : : : | : : : | L3... L60 |
| | | L L L L L L L | L L L L L L L | H H H H L L H | L61 |
| | L L L L L L L | L L L L L L L | H H H H H L L | L62 | |
| | Blue | L L L L L L L | L L L L L L L | H H H H H H H | Blue L63 |
| | Gray Scale of White & Black | Black | L L L L L L L | L L L L L L L | L L L L L L L |
| Dark ↑ ↓ Light | | L L L L L L H | L L L L L L H | L L L L L L H | L 1 |
| | | L L L L L H L | L L L L L H L | L L L L L H L | L 2 |
| | | : : : | : : : | : : : | L3... L60 |
| | | H H H H L L H | H H H H L L H | H H H H L L H | L61 |
| H H H H H L L | | H H H H H L L | H H H H H L L | L62 | |
| White | | H H H H H H H | H H H H H H H | H H H H H H H | White L63 |

**FOR SAFETY**

LCD module is generally designed with precise parts to achieve light weighted thin mechanical dimensions. In using our Modules, make certain that you fully understand and put into practice the warnings and safety precautions detailed in Engineering Information No.EE-N001,"CAUTIONS AND INSTRUCTIONS FOR TOSHIBA LCD MODULES". Refer to individual specifications and TECHNICAL DATA sheets (hereinafter called "TD") for more detailed technical information.

1) SPECIAL PURPOSES

A) Toshiba Matsushita Display Technology's Standard LCD Modules have not been customized for operation in extreme environments or for use in applications where performance failures could be life-threatening or otherwise catastrophic.

B) Since Toshiba Matsushita Display Technology's Standard LCD Modules have not been designed for operation in extreme environments, they must never be used in devices that will be exposed to abnormally high levels of vibration or shock which exceed Toshiba Matsushita Display Technology's published specification limits.

C) In addition, since Toshiba Matsushita Display Technology Standard LCD Modules have not been designed for use in applications where performance failures could be life-threatening or catastrophic, they must never be installed in aircraft navigation control systems (such as, but not limited to Traffic Collision Avoidance System and Air Traffic Indicator), in military defense or weapons systems, in critical industrial process-control systems (e.g., those involved in the production of nuclear energy), or in critical medical device or patient life-support systems.

2) DISASSEMBLING OR MODIFICATION

DO NOT DISASSEMBLE OR MODIFY the module. It may damage sensitive parts inside LCD module, and may cause scratches or dust on the display.

Toshiba Matsushita Display Technology does not warrant the module, if customer disassembled or modified it.

3) BREAKAGE OF LCD PANEL

DO NOT INGEST liquid crystal material, DO NOT INHALE this material, and DO NOT CONTACT the material with skin, if LCD panel is broken and liquid crystal material spills out.

If liquid crystal material comes into mouth or eyes, rinse mouth or eyes out with water immediately.

If this material contact with skin or cloths, wash it off immediately with alcohol and rinse thoroughly with water.

4) GLASS OF LCD PANEL

BE CAREFUL WITH CHIPS OF GLASS that may cause injuring fingers or skin, when the glass is broken.

5) ELECTRIC SHOCK

DISCONNECT POWER SUPPLY before handling LCD module.

DO NOT TOUCH the parts inside LCD module and the fluorescent lamp's connector or cables in order to prevent electric shock, because high voltage is supplied to these parts from the inverter unit while power supply is turned on.

6) ABSOLUTE MAXIMUM RATINGS AND POWER PROTECTION CIRCUIT

DO NOT EXCEED the absolute maximum rating values under the worst probable conditions caused by the supply voltage variation, input voltage variation, variation in parts' constants, environmental temperature, etc., otherwise LCD module may be damaged.

Employ protection circuit for power supply, whenever the specification or TD specifies it.

Suitable protection circuit should be applied for each system design.

7) RECOMMENDED OPERATION CONDITIONS

The performance and quality of the LCD panel are warranted only when the LCD panel is used within "the recommended operation conditions". Toshiba Matsushita Display Technology Co., Ltd. never warrants the performance and quality of the LCD panel when you use the LCD panel over "the recommended operation conditions", although within "the absolute maximum rating".

To use the LCD panel over "the recommended operation conditions" may have bad influence on the characteristics and reliability of the LCD panel and may shorten the life of the LCD panel.

Therefore, when designing the whole set, not to be over "the recommended operation conditions", you should fully take care of supply voltage change, characteristic of connection parts, surge of input-and-output line, and surrounding temperature.

8) DISPOSAL

When dispose LCD module, obey to the applicable environmental regulations.