



ALL RIGHTS RESERVED. NO PORTION OF THIS PUBLICATION, WHETHER IN WHOLE OR IN PART CAN BE REPRODUCED WITHOUT THE EXPRESS WRITTEN CONSENT OF SPC TECHNOLOGY.

SPC-F005.DWG

REVISIONS

DOC. NO. SPC-F005 \* Effective: 7/8/02 \* DCP No. 1398

DCP #	REV	DESCRIPTION	DRAWN	DATE	CHECKD	DATE	APPRVD	DATE
2070	A	Released	JN	09-03-09	JWM	09-03-09	JWM	09-03-09

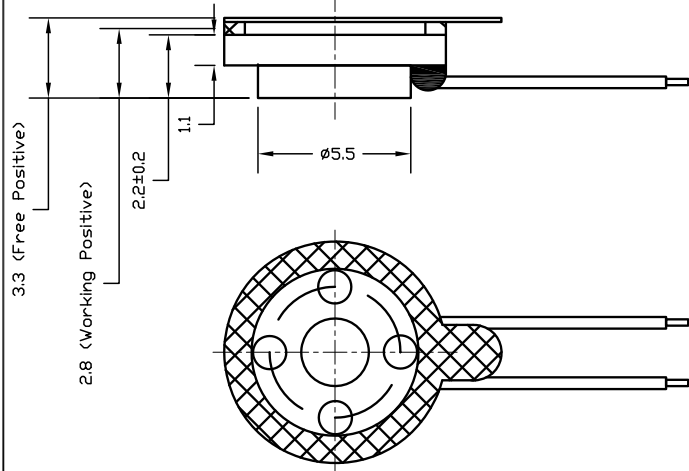
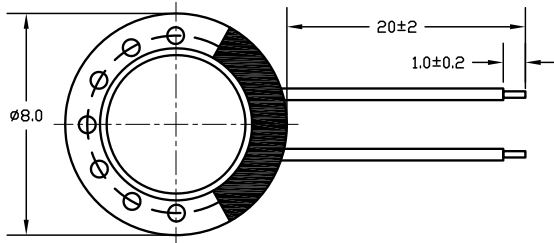

Item	Specification	Test Condition
Impedance	32Ω ± 15%	
Resonant Fr. (f <sub>o</sub> )	-	-
Frequency Range	300-3.4KHz	-
Rated Power	10mW	-
Max Power	30mW	-
S.P.L.	110± 3dB	1kHz/179mV
Distortion	<10% Max.	at 2kHz/0.56Vrms
Sweep Test	must be normal	at sine wave 0.56 V
Load Test	after test meet item 8	rated noise power, 24 Hrs.
Heat Test	after test meet item 8	55± 2°C 5Hrs.
Cold Test	after test meet item 8	-20± 2°C 5Hrs.
Humidity Test	after test meet item 8	40± 2°C, 90/95%R.H. 5Hrs.
Weight	-	-
Polarity Test	When supplied plus D.C. voltage to (+) terminal, the cone must move to forward.	

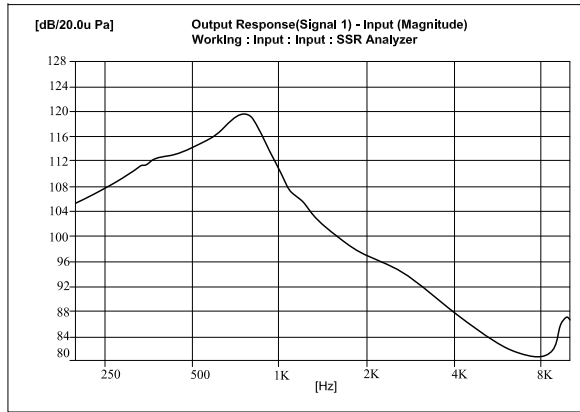

DISCLAIMER:  
ALL STATEMENTS AND TECHNICAL INFORMATION CONTAINED HEREIN ARE BASED UPON INFORMATION AND/OR TESTS WE BELIEVE TO BE ACCURATE AND RELIABLE. SINCE CONDITIONS OF USE ARE BEYOND OUR CONTROL, THE USER SHALL DETERMINE THE SUITABILITY OF THE PRODUCT FOR THE INTENDED USE AND ASSUME ALL RISK AND LIABILITY WHATSOEVER IN CONNECTION THEREWITH.

TOLERANCES:  
UNLESS OTHERWISE SPECIFIED, DIMENSIONS ARE FOR REFERENCE PURPOSES ONLY.

DRAWN BY:	DATE:
Jason Nash	09-03-09
CHECKED BY:	DATE:
Jason Nash	09-03-09
APPROVED BY:	DATE:
Jason Nash	09-03-09

DRAWING TITLE: <b>Speaker &amp; receiver</b>			
SIZE	DWG. NO.	ELECTRONIC FILE	REV
A	MCKP0822R1-4713	25R0883.dwg	A
SCALE: NTS	U.O.M.: INCHES [mm]	SHEET: 1 OF 1	