

PART NUMBER:

**USB-M2XFXX**

Packaging:  
 TR - tape/reel w/pick up pad  
 TU - tube  
 T0 - tape/reel w/out pad

Plating:  
 6 - selective flash gold  
 8 - selective 30u" gold  
 may require MOQ

SIGN	DATE	DESCRIPTION	APPROVER
THIS IS CAD DRAWING, DO NOT REVISE MANUALLY!!!			

**Material**

- Insulator: Glass Filled Polyamide
- Flammability: UL94V-0
- Contacts: Copper Alloy
- Shell: Copper Alloy
- Shell Plating: 120u" Tin over 30u" Nickel

**Ratings**

- Current: 1A
- Voltage: 30V AC(r.m.s.)
- Contact Resistance: <30mU
- Insulation Resistance: >1000 MU
- Dielectric Strength: 750V AC
- Operating Temp: 0°C - +40°C
- Storage Temp: -40°C - +60°C

RoHS Compliant

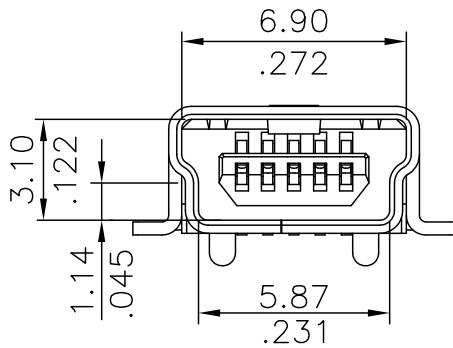
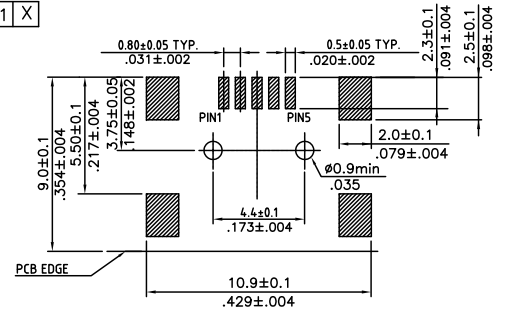
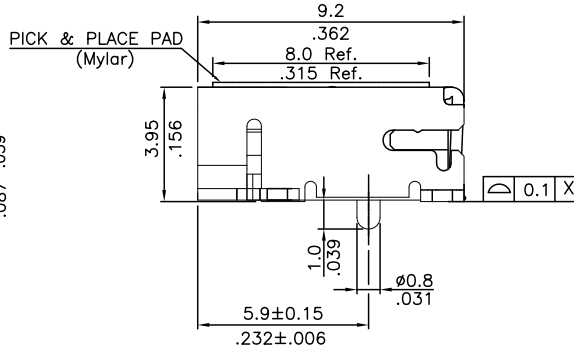
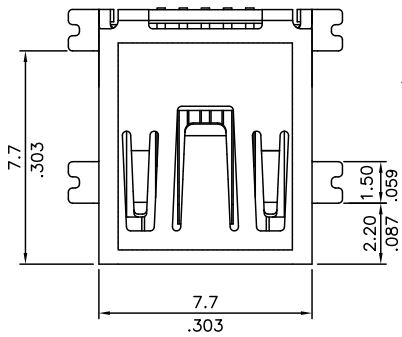

THESE DRAWINGS AND SPECIFICATIONS ARE THE PROPERTY OF ON-SHORE TECHNOLOGY, INC. AND SHALL NOT BE REPRODUCED, COPIED OR USED IN ANY MANNER WITHOUT THE PRIOR WRITTEN CONSENT OF ON-SHORE TECHNOLOGY, INC.

**OST** ON-SHORE TECHNOLOGY, INC.

TITLE		Mini USB - SMT Board Mount - B Type		
PART NO.	USB-M2XFXX	DWG NO.	USB-M2XFXX.DWG	
APPROVED	CHECKED	DESIGNED	DRAWN	4050
Stephen 2006.09.30	Marvin 2006.09.30	Sun 2006.09.30	Lee 2006.09.30	
SHEET: 1/1				Tolerance X* ±" X.XX ±0.20/008 X.XXX ±0.10/004 X.XXXX ±0.05/002
UNIT: mm/inches				SCALE: NONE
REV: B				