

DeviceNet

OPERATION MANUAL

OMRON

DeviceNet

Operation Manual

Revised April 2008

Notice:

OMRON products are manufactured for use according to proper procedures by a qualified operator and only for the purposes described in this manual.

The following conventions are used to indicate and classify precautions in this manual. Always heed the information provided with them. Failure to heed precautions can result in injury to people or damage to property.

 **DANGER** Indicates an imminently hazardous situation which, if not avoided, will result in death or serious injury. Additionally, there may be severe property damage.

 **WARNING** Indicates a potentially hazardous situation which, if not avoided, could result in death or serious injury. Additionally, there may be severe property damage.

 **Caution** Indicates a potentially hazardous situation which, if not avoided, may result in minor or moderate injury, or property damage.

OMRON Product References

All OMRON products are capitalized in this manual. The word "Unit" is also capitalized when it refers to an OMRON product, regardless of whether or not it appears in the proper name of the product.

The abbreviation "Ch," which appears in some displays and on some OMRON products, often means "word" and is abbreviated "Wd" in documentation in this sense.

The abbreviation "PLC" means Programmable Controller. "PC" is used, however, in some Programming Device displays to mean Programmable Controller.

Visual Aids

The following headings appear in the left column of the manual to help you locate different types of information.

Note Indicates information of particular interest for efficient and convenient operation of the product.

1,2,3... 1. Indicates lists of one sort or another, such as procedures, checklists, etc.

Trademarks and Copyrights

COMBICON is a registered trademark of PHOENIX CONTACT.

DeviceNet is a registered trademark of the Open DeviceNet Vendor Association, Inc.

PowerTap is a registered trademark of the Allen-Bradley Company, Inc.

© OMRON, 1996

All rights reserved. No part of this publication may be reproduced, stored in a retrieval system, or transmitted, in any form, or by any means, mechanical, electronic, photocopying, recording, or otherwise, without the prior written permission of OMRON.

No patent liability is assumed with respect to the use of the information contained herein. Moreover, because OMRON is constantly striving to improve its high-quality products, the information contained in this manual is subject to change without notice. Every precaution has been taken in the preparation of this manual. Nevertheless, OMRON assumes no responsibility for errors or omissions. Neither is any liability assumed for damages resulting from the use of the information contained in this publication.

TABLE OF CONTENTS

PRECAUTIONS	xv
1 Intended Audience	xvi
2 General Precautions	xvii
3 Safety Precautions	xviii
4 Operating Environment Precautions	xx
5 Application Precautions	xxi
SECTION 1	
Introduction	1
1-1 DeviceNet Network Features	2
1-2 DeviceNet-compatible Devices	4
1-3 Communications Specifications	17
1-4 Basic Operating Procedures	18
SECTION 2	
Network Configuration and Wiring	21
2-1 Network Configuration Overview	22
2-2 Network Configuration	32
2-3 Cables, Connectors, and Related Devices	43
2-4 Wiring Methods	62
2-5 Minimizing Noise in the Network	82
2-6 Operational Checklist	85
SECTION 3	
Communications Power Supply Methods	87
3-1 Basic Concepts	88
3-2 Flowchart: Determining Power Supply Requirements	89
3-3 Locating the Power Supply	90
3-4 Step 1: Evaluating the Configuration with Graphs	92
3-5 Step 2: Evaluating the Configuration with Calculations	96
3-6 Step 3: Splitting the System into Multiple Power Supplies	101
Appendices	
A Connectable Device Lists	103
B Dimensions of Connectable Devices	119
C Current Consumption of DeviceNet Devices	131
Index	137
Revision History	141

About this Manual:

This manual describes the configuration and installation of an OMRON DeviceNet network and includes the sections described below.

Please read this manual carefully and be sure you understand the information provided before attempting to install or operate the DeviceNet network. **Be sure to read the precautions provided in the following section.**

The following manuals also cover information related to DeviceNet applications. Use the *DeviceNet Operation Manual* together with other required manuals.

Manual	Contents	Cat. No.
DeviceNet Operation Manual (this manual)	Describes the configuration and construction of a DeviceNet network, including installation procedures and specifications for cables, connectors, and other connection devices, as well as information on functions, operating procedures, and applications.	W267
DeviceNet CS/CJ Series Units Operation Manual	Describes the models, specifications, functions, operating procedures, and applications of CS-series and CJ-series DeviceNet Master Units.	W380
DeviceNet Masters Operation Manual	Describes the models, specifications, functions, operating procedures, and applications of C200HX/HG/HE, CVM1, and CV-series DeviceNet Master Units.	W379
DeviceNet DRT1 Series Slaves Operation Manual	Describes the models, specifications, functions, operating procedures, and applications of DRT1-series Smart Slave Units.	W347
DeviceNet DRT2 Series Slaves Operation Manual	Describes the models, specifications, functions, operating procedures, and applications of DRT2-series Smart Slave Units.	W404
DeviceNet Configurator Ver. 2.□ Operation Manual	Describes the operating procedures of the DeviceNet Configurator.	W382
DeviceNet MULTIPLE I/O TERMINAL Operation Manual	Describes the models, specifications, functions, operating procedures, and applications of the DeviceNet MULTIPLE I/O TERMINALS.	W348

Precautions provides general precautions for planning, installing, and operating the DeviceNet network and related devices.

Section 1 provides an overview of the DeviceNet network, including features, compatible OMRON DeviceNet devices, communications specifications, and basic operating procedures.

Section 2 explains how to plan the Network configuration and connect the Network's communications wiring.

Section 3 describes the DeviceNet communications power supply methods and provides a step-by-step procedure to determine the ideal location for the power supply (or power supplies.)

Appendix A provides lists of OMRON's DeviceNet devices.

Appendix B shows the dimensions of the DeviceNet devices.

Appendix C shows the current requirements of the DeviceNet devices.



WARNING Failure to read and understand the information provided in this manual may result in personal injury or death, damage to the product, or product failure. Please read each section in its entirety and be sure you understand the information provided in the section and related sections before attempting any of the procedures or operations given.

Read and Understand this Manual

Please read and understand this manual before using the product. Please consult your OMRON representative if you have any questions or comments.

Warranty and Limitations of Liability

WARRANTY

OMRON's exclusive warranty is that the products are free from defects in materials and workmanship for a period of one year (or other period if specified) from date of sale by OMRON.

OMRON MAKES NO WARRANTY OR REPRESENTATION, EXPRESS OR IMPLIED, REGARDING NON-INFRINGEMENT, MERCHANTABILITY, OR FITNESS FOR PARTICULAR PURPOSE OF THE PRODUCTS. ANY BUYER OR USER ACKNOWLEDGES THAT THE BUYER OR USER ALONE HAS DETERMINED THAT THE PRODUCTS WILL SUITABLY MEET THE REQUIREMENTS OF THEIR INTENDED USE. OMRON DISCLAIMS ALL OTHER WARRANTIES, EXPRESS OR IMPLIED.

LIMITATIONS OF LIABILITY

OMRON SHALL NOT BE RESPONSIBLE FOR SPECIAL, INDIRECT, OR CONSEQUENTIAL DAMAGES, LOSS OF PROFITS OR COMMERCIAL LOSS IN ANY WAY CONNECTED WITH THE PRODUCTS, WHETHER SUCH CLAIM IS BASED ON CONTRACT, WARRANTY, NEGLIGENCE, OR STRICT LIABILITY.

In no event shall the responsibility of OMRON for any act exceed the individual price of the product on which liability is asserted.

IN NO EVENT SHALL OMRON BE RESPONSIBLE FOR WARRANTY, REPAIR, OR OTHER CLAIMS REGARDING THE PRODUCTS UNLESS OMRON'S ANALYSIS CONFIRMS THAT THE PRODUCTS WERE PROPERLY HANDLED, STORED, INSTALLED, AND MAINTAINED AND NOT SUBJECT TO CONTAMINATION, ABUSE, MISUSE, OR INAPPROPRIATE MODIFICATION OR REPAIR.

Application Considerations

SUITABILITY FOR USE

OMRON shall not be responsible for conformity with any standards, codes, or regulations that apply to the combination of products in the customer's application or use of the products.

At the customer's request, OMRON will provide applicable third party certification documents identifying ratings and limitations of use that apply to the products. This information by itself is not sufficient for a complete determination of the suitability of the products in combination with the end product, machine, system, or other application or use.

The following are some examples of applications for which particular attention must be given. This is not intended to be an exhaustive list of all possible uses of the products, nor is it intended to imply that the uses listed may be suitable for the products:

- Outdoor use, uses involving potential chemical contamination or electrical interference, or conditions or uses not described in this manual.
- Nuclear energy control systems, combustion systems, railroad systems, aviation systems, medical equipment, amusement machines, vehicles, safety equipment, and installations subject to separate industry or government regulations.
- Systems, machines, and equipment that could present a risk to life or property.

Please know and observe all prohibitions of use applicable to the products.

NEVER USE THE PRODUCTS FOR AN APPLICATION INVOLVING SERIOUS RISK TO LIFE OR PROPERTY WITHOUT ENSURING THAT THE SYSTEM AS A WHOLE HAS BEEN DESIGNED TO ADDRESS THE RISKS, AND THAT THE OMRON PRODUCTS ARE PROPERLY RATED AND INSTALLED FOR THE INTENDED USE WITHIN THE OVERALL EQUIPMENT OR SYSTEM.

PROGRAMMABLE PRODUCTS

OMRON shall not be responsible for the user's programming of a programmable product, or any consequence thereof.

Disclaimers

CHANGE IN SPECIFICATIONS

Product specifications and accessories may be changed at any time based on improvements and other reasons.

It is our practice to change model numbers when published ratings or features are changed, or when significant construction changes are made. However, some specifications of the products may be changed without any notice. When in doubt, special model numbers may be assigned to fix or establish key specifications for your application on your request. Please consult with your OMRON representative at any time to confirm actual specifications of purchased products.

DIMENSIONS AND WEIGHTS

Dimensions and weights are nominal and are not to be used for manufacturing purposes, even when tolerances are shown.

PERFORMANCE DATA

Performance data given in this manual is provided as a guide for the user in determining suitability and does not constitute a warranty. It may represent the result of OMRON's test conditions, and the users must correlate it to actual application requirements. Actual performance is subject to the OMRON Warranty and Limitations of Liability.

ERRORS AND OMISSIONS

The information in this manual has been carefully checked and is believed to be accurate; however, no responsibility is assumed for clerical, typographical, or proofreading errors, or omissions.

PRECAUTIONS

This section provides general precautions for installing and using the DeviceNet network and related devices.

The information contained in this section is important for the safe and reliable application of the DeviceNet network. You must read this section and understand the information contained before attempting to set up or operate a DeviceNet network.

1	Intended Audience	xvi
2	General Precautions	xvii
3	Safety Precautions.....	xviii
4	Operating Environment Precautions	xx
5	Application Precautions	xxi

1 Intended Audience

This manual is intended for the following personnel, who must also have knowledge of electrical systems (an electrical engineer or the equivalent).

- Personnel in charge of purchasing FA systems.
- Personnel in charge of designing FA systems.
- Personnel in charge of installing and connecting FA systems.
- Personnel in charge of managing FA systems and facilities.

2 General Precautions

The user must operate the product according to the specifications described in the operation manuals.

Before using the product under conditions which are not described in the manual or applying the product to nuclear control systems, railroad systems, aviation systems, vehicles, combustion systems, medical equipment, amusement machines, safety equipment, and other systems, machines, and equipment that may have a serious influence on lives and property if used improperly, consult your OMRON representative.

Make sure that the ratings and performance characteristics of the product are sufficient for the systems, machines, and equipment, and be sure to provide the systems, machines, and equipment with redundant safety mechanisms.

This manual provides information for installing and operating OMRON DeviceNet products. Be sure to read this manual before operation and keep this manual close at hand for reference during operation.

 **WARNING** It is extremely important that a PLC and all PLC Units be used for the specified purpose and under the specified conditions, especially in applications that can directly or indirectly affect human life. You must consult with your OMRON representative before applying a PLC system to the above mentioned applications.

3 Safety Precautions

 **WARNING** Never attempt to disassemble any Units while power is being supplied. Doing so may result in serious electrical shock or electrocution.

 **WARNING** Make sure that the current or voltage input to the Unit is within the specified ranges. Using a current or voltage outside of the specified range may result in damage or fire.

 **WARNING** Provide safety measures in external circuits (i.e., not in the Programmable Controller), including the following items, to ensure safety in the system if an abnormality occurs due to malfunction of the PLC or another external factor affecting the PLC operation. Not doing so may result in serious accidents.

1. Emergency stop circuits, interlock circuits, limit circuits, and similar safety measures must be provided in external control circuits.
2. The PLC will turn OFF all outputs when its self-diagnosis function detects any error or when a severe failure alarm (FALS) instruction is executed. External safety measures must be provided to ensure safety in the system in case an error or FALS instruction causes all outputs to be turned OFF.
3. The PLC outputs may remain ON or OFF due to fusing or burning of the output relay contacts or destruction of the output transistors. External safety measures must be provided to ensure safety in the system in case the outputs fail and remain ON or OFF.
4. When the 24-V DC output (service power supply to the PLC) is overloaded or short-circuited, the voltage may drop and result in the outputs being turned OFF. External safety measures must be provided to ensure safety in the system in case of a power supply problem that causes outputs to be turned OFF.

 **WARNING** The PLC's CPU Unit continues I/O refreshing even when the program is not being executed (in PROGRAM mode). Before proceeding with any of the following operations, verify that it is safe to do so in case the operation changes the status of output bits allocated to Output Units or the data allocated to Special I/O Units or CPU Bus Units. It is possible for a load connected to an Output Unit, Special I/O Unit, or CPU Bus Unit to operate unexpectedly.

- Using a Programming Device (Support Software in a personal computer) to transfer data to the CPU Unit's I/O memory area.
- Using a Programming Device to change present values
- Using a Programming Device to force-set or force-reset bits
- Transferring an I/O memory file to the CPU Unit from EM file memory
- Transferring I/O memory from another PLC or host computer in the network

 **Caution** Execute online edit only after confirming that no adverse effects will be caused by extending the cycle time. Otherwise, the input signals may not be readable.

 **Caution** Confirm safety at the destination node before transferring or changing the program, PLC Setup, I/O table, or I/O memory in another node. Changing data in another node without confirming safety may cause unexpected operation and result in injury.

4 Operating Environment Precautions

Install the system properly according to the directions in this manual.

Do not operate the control system in the following places.

- Locations subject to direct sunlight.
- Locations subject to temperatures or humidity outside the range specified in the specifications.
- Locations subject to condensation as the result of severe changes in temperature.
- Locations subject to corrosive or flammable gases.
- Locations subject to dust (especially iron dust) or salts.
- Locations subject to water, oil, or chemicals.
- Locations subject to shock or vibration.

Take appropriate and sufficient countermeasures when installing systems in the following locations:

- Locations subject to static electricity or other forms of noise.
- Locations subject to strong electromagnetic fields.
- Locations subject to possible exposure to radioactivity.
- Locations close to power supplies.

5 Application Precautions

- Fail-safe measures must be taken by the customer to ensure safety in the event of incorrect, missing, or abnormal signals caused by broken signal lines, momentary power interruptions, or other causes.
- Emergency stop circuits, interlock circuits, limit circuits, and similar safety measures must be provided in external control circuits (i.e., not in the Programmable Controller).
- Use the power supplies specified in the operation manuals.
- If the system is installed at a site with poor power supply conditions, take appropriate measures to ensure that the power supply remains within the rated voltage and frequency specifications.
- Install external breakers and take other safety measures against short-circuiting in external wiring. Insufficient safety measures against short-circuiting may result in burning.
- Always ground the system to 100 Ω or less when installing the system to protect against electrical shock.
- Make sure that the Unit is securely mounted, either to the DIN Track or by screws.
- Always turn OFF the communications power supply and the power supplies to the PLC and Slaves before attempting any of the following.
 - Mounting or removing a Unit such as an I/O Unit, Power Supply Unit, CPU Unit, Memory Cassette, or Master Unit.
 - Connecting or disconnecting Remote I/O Terminal circuits.
 - Assembling any devices or racks.
 - Setting DIP switches or rotary switches.
 - Connecting or wiring cables.
 - Connecting or disconnecting connectors.
- Do not attempt to disassemble, repair, or modify any Units.
- Make sure that the terminal block screws are tightened to the torque specified in the relevant manuals. Loose screws may result in fire, malfunction, or damage.
- Confirm that no adverse effect will occur in the system before attempting any of the following.
 - Changing the operating mode of the PLC (including the operating mode setting when the power is turned ON)
 - Force-setting/force-resetting any bit in memory
 - Changing the present value of any word or any set value in memory
- Make sure that all the mounting screws, terminal screws, and cable connector screws are tightened to the torque specified in the relevant manuals.
- Make sure that communications connector screws are securely tightened to a torque of 0.5 to 0.6 N·m.
- Use crimp terminals for wiring. Do not connect bare stranded wires directly to terminals.
- Double-check all wiring and switch settings before turning ON the power supply.
- Make sure that metal filings do not get inside of the Unit during wiring and installation.

- Make sure that the polarity of terminals, the wiring of communications paths, the wiring of the power supply, and the voltage for inputs and outputs are correct. If any of these are incorrect, it may result in damage.
- Perform the wiring correctly according to the instructions in this manual.
- Make sure that the connection distances are within specifications.
- Mount Units only after checking terminal blocks and connectors completely.
- Make sure that the communications cable connectors and other items with locking devices are properly locked into place.
- Do not drop the Unit or subject it to abnormal vibration or impact, or it may result in damage or malfunctioning.
- Use the special packing box when transporting the Unit. Ensure that the product is handled carefully so that no excessive vibration or impact is applied to the product during transportation.
- Check the user program for proper execution before actually running it with the system.
- Do not pull on the cables or bend them past their natural bending radius.
- Before connecting communications cables, be sure to first turn OFF the communications power supply, the power supply to the PLC, and the power supply to all Slaves.
- Use only the specified DeviceNet cables as communications cables.
- Observe the following precautions when wiring the communications cables.
 - Wire the cables separately from the power lines or high-tension lines.
 - Do not bend the cables excessively.
 - Do not pull on the cables excessively.
 - Do not place objects on top of the cables.
 - Route cables inside ducts.
- Before touching a Unit, touch a grounded metallic object in order to discharge any static build-up.
- Always enable the scan list before operation.
- Before clearing the scan list for a Unit set for automatic allocation of remote I/O, make sure that it will not cause any problems for the I/O area to be changed to fixed allocations.
- When adding a new node to the network, check that the new node's baud rate is the same as the baud rate set on the other nodes.
- When a CPU Unit or Special I/O Unit is being replaced, always transfer any required data, such as DM and HR area settings and parameters, before restarting the system.
- Follow the specifications for the communications distances and the number of connected Units.

SECTION 1

Introduction

This section provides an overview of the DeviceNet network, including features, specifications, and the system configurations.

1-1	DeviceNet Network Features	2
1-1-1	Reduced Wiring	2
1-1-2	Multi-vendor Networks.....	2
1-1-3	Remote I/O Communications and Message Communications.....	3
1-1-4	Device Profiles	3
1-2	DeviceNet-compatible Devices.....	4
1-2-1	Master Unit Models	4
1-2-2	DeviceNet Functions of OMRON Master Units.....	4
1-2-3	Types of Slaves.....	7
1-2-4	DeviceNet Configurator	17
1-3	Communications Specifications	17
1-4	Basic Operating Procedures	18
1-4-1	DeviceNet Network Configuration and Wiring	18
1-4-2	Network Start-up Procedure	18

1-1 DeviceNet Network Features

DeviceNet is an open field network that can easily connect a variety of control devices such as PLCs, personal computers, sensors, and actuators.

The DeviceNet network not only reduces wiring and maintenance costs because it requires less wiring, it also allows DeviceNet-compatible devices from different manufacturers to be connected. There is a wide selection of DeviceNet-compatible devices available, so a more economical system can be constructed.

1-1-1 Reduced Wiring

Use DeviceNet cables to wire connections such as multi-drop trunk lines and T-branch lines. These connection methods can help reduce onsite wiring costs and maintenance costs.

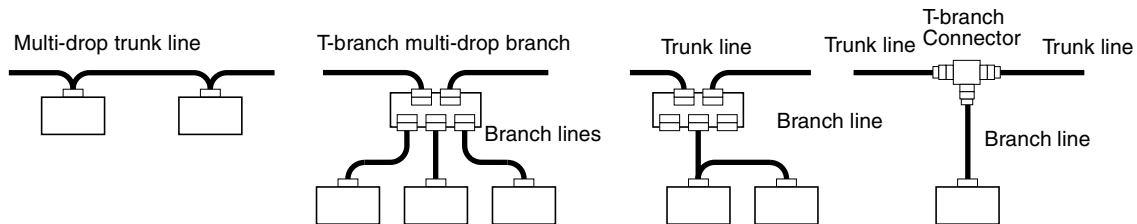

1-1-2 Multi-vendor Networks

The DeviceNet communications specifications are open and standardized, so a DeviceNet-compatible device from any manufacturer can be connected. DeviceNet can be used in a variety of field-level applications by combining devices such as valves and sensors.

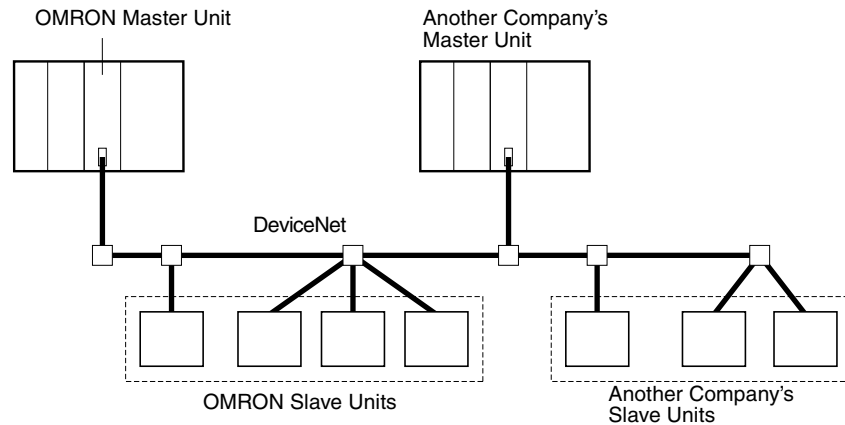

1-1-3 Remote I/O Communications and Message Communications

DeviceNet supports message communications as well as remote I/O communications. Message communications can be used to make device settings and monitor operation.

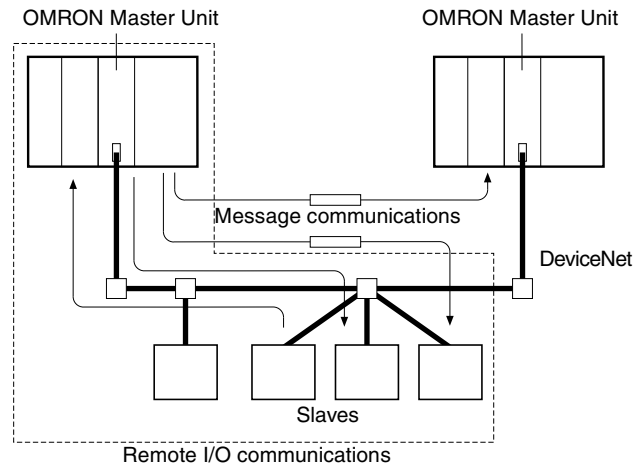

1-1-4 Device Profiles

Since device profiles are defined in DeviceNet, devices are compatible and replaceable even in a multi-vendor environment.

It is possible to set each device's parameters and monitor operation easily from the Configurator based on the device's profile data.

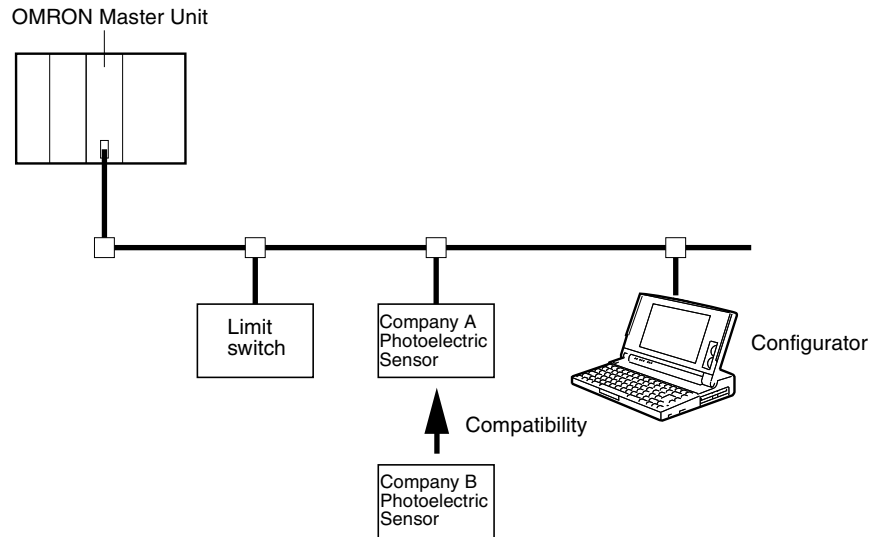

1-2 DeviceNet-compatible Devices

1-2-1 Master Unit Models

Applicable PLC	Master Unit model number	Mounting position	Master/Slave functions	Max. number of Units	
				With Configurator	Without Configurator
CS Series	CS1W-DRM21(-V1)	CPU Rack or Expansion I/O Rack (Classified as CPU Bus Units)	Master and Slave functions	16	
CJ Series	CJ1W-DRM21				
CVM1, CV Series	CVM1-DRM21-V1	CPU or Expansion CPU Rack (Classified as CPU Bus Units)	Master function only	16	1
CS Series	C200HW-DRM21-V1	CPU Rack or Expansion I/O Rack (Classified as Special I/O Units)		16	
C200HZ/HX/HG/HE				10 or 16	
C200HS				10	

1-2-2 DeviceNet Functions of OMRON Master Units

Remote I/O Master Function

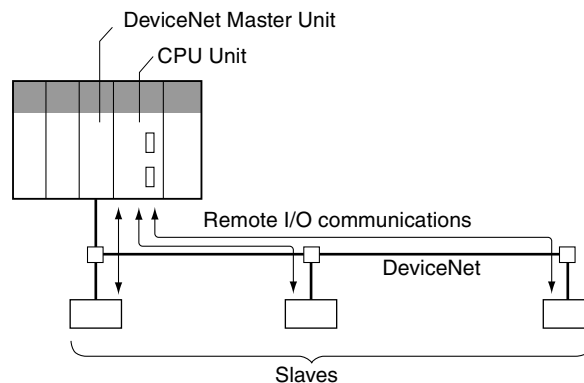

Item	Master	Model	Without Configurator	With Configurator
Max. No. of Slave nodes per Master	CS Series	CS1W-DRM21(-V1)	63 nodes	
	CJ Series	CJ1W-DRM21	63 nodes	
	CVM1, CV Series	CVM1-DRM21-V1	63 nodes	
	CS Series, C200HX/HG/HE	C200HW-DRM21-V1	50 nodes	63 nodes
	C200HS		32 nodes	63 nodes
Max. No. of control points per Master	CS Series	CS1W-DRM21(-V1)	2,048 pts (64 input /64 output words) or 16,000 pts (500 input/500 output words)	32,000 pts (500 words x 4 blocks)
	CJ Series	CJ1W-DRM21		
	CVM1, CV Series	CVM2-DRM21-V1	2,048 pts (64 input/ 64 output words)	6,400 (100 words x 4 blocks)
	CS Series, C200HX/HG/HE	C200HW-DRM21-V1	1,600 pts (50 input/50 output words)	Without messages: 4,800 pts With messages: 1,600 pts
	C200HS		1,024 pts (32 input/32 output words)	1,280

Item	Master	Model	Without Configurator	With Configurator
Max. No. of I/O points per Slave controllable by Master	CS Series	CS1W-DRM21(-V1)	100 input words x 2/100 output words x 1	
	CJ Series	CJ1W-DRM21		
	CVM1, CV Series	CVM1-DRM21-V1	32 input/32 output words	
	CS Series, C200HX/HG/HE	C200HW-DRM21-V1		
	C200HS			
Remote I/O allocation areas	CS Series	CS1W-DRM21(-V1)	CS/CJ DeviceNet words in CIO Area, and user-allocated words in CIO Area, DM Area, and other areas.	User-allocated words in CIO Area, DM Area, and other areas.
	CJ Series	CJ1W-DRM21		
	CVM1, CV Series	CVM1-DRM21-V1	DeviceNet Area (including dedicated words/ bits)	User-allocated words in CIO Area, DM Area, and other areas.
	CS Series, C200HX/HG/HE	C200HW-DRM21-V1		
	C200HS			

Remote I/O Slave Function

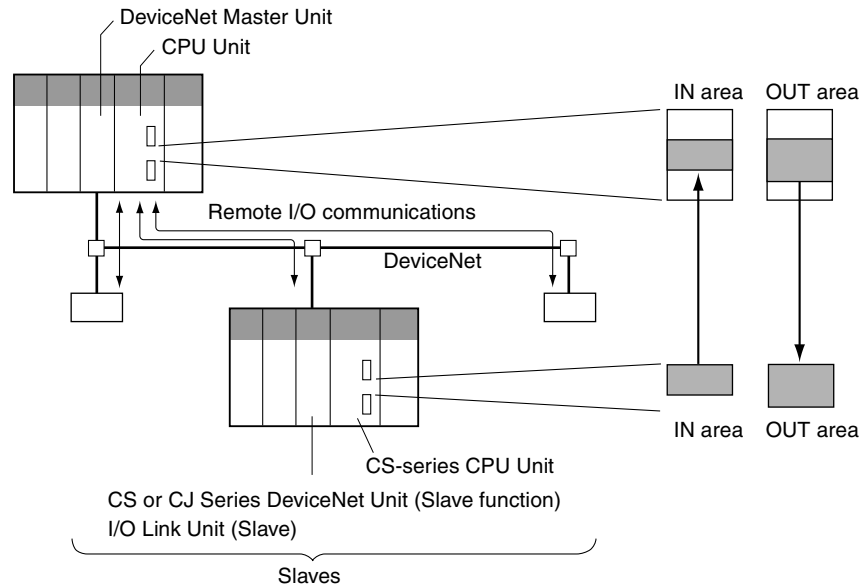

Item	CPU Unit to which a Slave is mounted	Unit Model	Without the Configurator	With the Configurator
Max. No. of I/O pts per Slave	CS Series	CS1W-DRM21(-V1)	32 pts (1 input/ 1 output word) or 3,200 pts (100 input/100 output words)	4,800 pts (100 input words x 2/100 output words x 1)
	CJ Series	CJ1W-DRM21		
	CS Series, C200HX/HG/HE	C200HW-DRT21	1,024 pts (32 input/32 output words)	
	CQM1H CQM1 Series	CQM1-DRT21	32 pts (1 input/1 output word)	
Allocation areas in the CPU Unit to which this Slave is mounted	CS Series	CS1W-DRM21(-V1)	CIO, WR, DM, EM, HR	
	CJ Series	CJ1W-DRM21		
	CS Series, C200HX/HG/HE	C200HW-DRM21	CIO, DM, EM, AR, LR, T/C	
	CQM1H CQM1 Series	CQM1-DRT21	CIO	

Message Communications Function

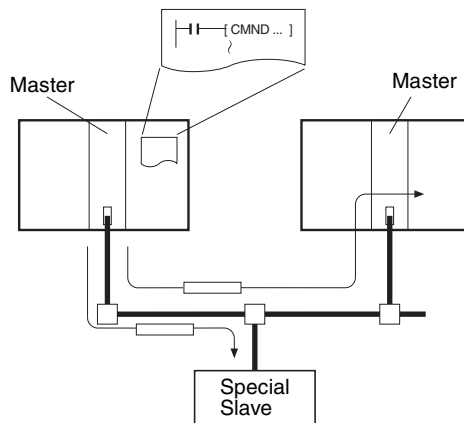

Item	Master	Unit model	Send	Receive	FINS commands
Communications Instructions	CS Series	CS1W-DRM21(-V1)	SEND(192)	RECV(193)	CMND(194)
	CJ Series	CJ1W-DRM21	SEND(192)	RECV(193)	CMND(194)
	CVM1, CV Series	DVM1-DRM21-V1	SEND(192)	RECV(193)	CMND(194)
	CS Series, C200HX/HG/HE	C200HW-DRM21-V1	None	None	IOWR
	C200HS		---		

Item	Master model	Model	Capacity
Max. No. of nodes per Master for message communications using FINS commands	CS Series	CS1W-DRM21(-V1)	63 nodes
	CJ Series	CJ1W-DRM21	
	CVM1, CV Series	CVM1-DRM21-V1	8 nodes
	CS Series, C200HX/HG/HE	C200HW-DRM21-V1	8 nodes
	C200HS		Not supported
Max. No. of nodes per Master for message communications using explicit messages	CS Series	CS1W-DRM21(-V1)	63 nodes
	CJ Series	CJ1W-DRM21	
	CVM1, CV Series	CVM1-DRM21-V1	63 nodes
	CS Series, C200HX/HG/HE	C200HW-DRM21-V1	63 nodes
	C200HS		Not supported
Max. message length	CS Series	CS1W-DRM21(-V1)	SEND(192): 267 words
	CJ Series	CJ1W-DRM21	RECV(193): 269 words CMND(194): 542 bytes (starting with command code)
	CVM1, CV Series	CVM1-DRM21-V1	SEND(192): 76 words RECV(193): 78 words CMND(194): 160 bytes (starting with command code)
	CS Series, C200HX/HG/HE	C200HW-DRM21-V1	IOWR(223): 160 bytes (starting with command code)

1-2-3 Types of Slaves

The following classifications are used for DeviceNet Slaves.

For more details on the General-purpose Slaves, Environment-resistive Slaves, and Special Slaves, refer to the *DeviceNet DRT1 Series Slaves Operation Manual (W347)* for DRT1-series Slaves and the *DeviceNet DRT2 Series Slaves Operation Manual (W404)* for DRT2-series Slaves.

Refer to the *DeviceNet MULTIPLE I/O TERMINAL Operation Manual (W348)* for more details on the MULTIPLE I/O TERMINAL Slaves.

General-purpose Slaves

Slaves with I/O functions for 32 or fewer inputs and 32 or fewer outputs.

Environment-resistive Slaves

Slave with I/O functions for I/O that uses a round, waterproof connector connected to a communications cable.

Special Slaves

Slaves with more than 32 inputs or 32 outputs or Slaves with functions other than I/O.

MULTIPLE I/O TERMINALS These are high-density I/O Block Slaves.

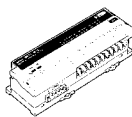
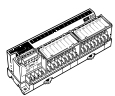

1-2-3-1 DRT1-series Slaves

General-purpose Slaves

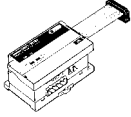
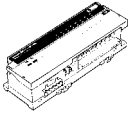
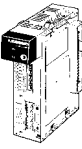
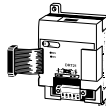

Name	Appearance	I/O points	Model number	Communications cable	Remarks
Remote I/O Terminals with Transistors		8 input points (NPN)	DRT1-ID08	Normal square connectors	---
		8 input points (PNP)	DRT1-ID08-1		
		16 input points (NPN)	DRT1-ID16		
		16 input points (PNP)	DRT1-ID16-1		
		8 output points (NPN)	DRT1-OD08		
		8 output points (PNP)	DRT1-OD08-1		
		16 output points (NPN)	DRT1-OD16		
		16 output points (PNP)	DRT1-OD16-1		
		8 input points+8 output points (NPN)	DRT1-MD16		
Remote I/O Terminals with Transistors and 3-tier Terminal Block		16 input points (NPN)	DRT1-ID16T		Simple wiring (not necessary to tighten multiple wires together and wiring locations are easy to understand) The DRT1-ID16TA(-1) does not need a separate power supply for internal circuits (uses the communications power supply).
		16 input points (PNP)	DRT1-ID16T-1		
		16 input points (NPN)	DRT1-ID16TA		
		16 input points (PNP)	DRT1-ID16TA-1		
		16 output points (NPN)	DRT1-OD16T		
		16 output points (PNP)	DRT1-OD16T-1		
		16 output points (NPN)	DRT1-OD16TA		
		16 output points (PNP)	DRT1-OD16TA-1		
		8 input points+8 output points (NPN)	DRT1-MD16T		
		8 input points+8 output points (PNP)	DRT1-MD16T-1		
		8 input points+8 output points (NPN)	DRT1-MD16TA		
		8 input points+8 output points (PNP)	DRT1-MD16TA-1		

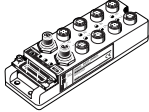
Name	Appearance	I/O points	Model number	Communi-cations cable	Remarks
Remote I/O Terminals with Transistors and Connectors		32 input points (NPN)	DRT1-ID32ML	Normal square connectors	Compact (35 x 60 x 80 mm (W x D x H)) Connects to a Relay Terminal through a MIL cable. Does not need a separate power supply for internal circuits (uses the communications power supply).
		32 input points (PNP)	DRT1-ID32ML-1		
		32 output points (NPN)	DRT1-OD32ML		
		32 output points (PNP)	DRT1-OD32ML-1		
		16 input points+16 output points (NPN)	DRT1-MD32ML		
		16 input points+16 output points (PNP)	DRT1-MD32ML-1		
Remote Adapters		16 input points (NPN)	DRT1-ID16X		Compact (85 x 50 x 40 mm W x D x H) Connects to a G70D Relay terminal and can be used for a relay output or a power MOSFET relay output.
		16 input points (PNP)	DRT1-ID16X-1		
		16 output points (NPN)	DRT1-OD16X		
		16 output points (PNP)	DRT1-OD16X-1		
Sensor Terminals		16 input points (NPN)	DRT1-HD16S		Connected to photoelectric and proximity sensors with connectors
		8 input/8 output points (PNP)	DRT1-ND16S		
CQM1 I/O Link Unit		16 internal inputs/ 16 internal outputs (between CQM1 and Master)	CQM1-DRT21		Remote I/O communications between PLCs
CPM2A/ CPM1A I/O Link Unit		32 internal inputs/ 32 internal outputs (between CPM2A/ CPM1A and Master)	CPM1A-DRT21		Remote I/O communications between PLCs

Waterproof and Environment-resistive Slaves

Name	Appearance	I/O points	Model number	Communications cable	Remarks
Waterproof Terminals		4 input points (NPN)	DRT1-ID04CL	Round connectors	Dust and drip-proof structure for environmental resistance (IP 67) XS2 Series connector system eliminates the need for tools for sensor, valve or other connections.
		4 input points (PNP)	DRT1-ID04CL-1		
		8 input points (NPN)	DRT1-ID08CL		
		8 input points (PNP)	DRT1-ID08CL-1		
		4 output points (NPN)	DRT1-OD04CL		
		4 output points (PNP)	DRT1-OD04CL-1		
		8 output points (NPN)	DRT1-OD08CL		
		8 output points (PNP)	DRT1-OD08CL-1		
Environment-resistive Terminals		8 input points (NPN)	DRT1-ID08C		Spatter, dust and drip-proof structure for environmental resistance (IP 66) XS2 Series connector system eliminates the need for tools for sensor, valve or other connections.
		8 output points (NPN)	DRT1-OD08C		
		16 input points (NPN)	DRT1-HD16C		
		16 input points (PNP)	DRT1-HD16C-1		
		16 output points (NPN)	DRT1-WD16C		
		16 output points (PNP)	DRT1-WD16C-1		
		8 input points+8 output points (NPN)	DRT1-MD16C		
		8 input points+8 output points (PNP)	DRT1-MD16C-1		
B7AC Interface Terminal		10 input points x 3	DRT1-B7AC		Splits 1 B7AC Unit into 3 branches. XS2 Series connector system eliminates the need for tools. Spatter, dust and drip-proof structure for environmental resistance (IP 66)

Special Slaves

Name	Appearance	I/O points	Model number	Communi- cations cable	Remarks
Programma- ble Slaves		512 inputs max. (32 words) 512 outputs max. (32 words)	CPM2C-S100C- DRT CPM2C-S110C- DRT	Normal square con- nectors	Controller that enables communications with Com- poBus/S Master. Enables message commu- nications using explicit messages.
C200H I/O Link Unit		512 inputs max. (32 words) 512 outputs max. (32 words)	C200HW-DRT21		Supports remote I/O and message communications between PLCs. Max. I/O area: 512 input points and 52 output points Any I/O words can be allo- cated.
RS-232C Unit		16 inputs (1 word)	DRT1-232C2		Two RS-232C ports mounted Data sent and received by explicit message (151 bytes max.) Executes settings and con- trol through explicit mes- sages. Reflects RS-232C port sta- tus in the input.

1-2-3-2 DRT2-series Slaves

General-purpose Slaves

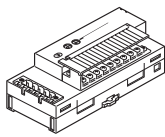
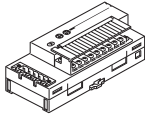
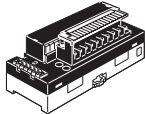
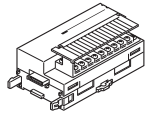
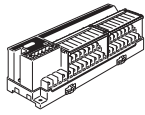
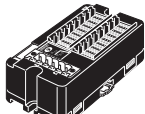
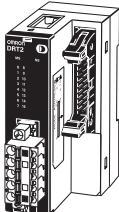
Name	Appearance	I/O points	Model number	Remarks
Remote I/O Terminals with Transistors		8 input points (NPN)	DRT2-ID08	Terminal block mounted/removed using screws.
		8 input points (PNP)	DRT2-ID08-1	
		8 output points (NPN)	DRT2-OD08	
		8 output points (PNP)	DRT2-OD08-1	
		16 input points (NPN)	DRT2-ID16	
		16 input points (PNP)	DRT2-ID16-1	
		16 output points (NPN)	DRT2-OD16	
		16 output points (PNP)	DRT2-OD16-1	
		8 input points/8 output points (NPN)	DRT2-MD16	
		8 input points/8 output points (PNP)	DRT2-MD16-1	
Remote I/O Terminals with Relay Outputs		16 output points	DRT2-ROS16	Relay outputs
Remote I/O Terminal Expansion Units with Transistors		16 input points (NPN)	XWT-ID16	Expansion Unit for increasing inputs or outputs of the Basic Unit.
		16 input points (PNP)	XWT-ID16-1	
		16 output points (NPN)	XWT-OD16	
		16 output points (PNP)	XWT-OD16-1	
		8 input points (NPN)	XWT-ID08	
		8 input points (PNP)	XWT-ID08-1	
		8 output points (NPN)	XWT-OD08	
		8 output points (PNP)	XWT-OD08-1	
Remote I/O Terminals with 3-tier Terminal Blocks and Transistors		16 input points (NPN)	DRT2-ID16TA	Wiring locations easy to find (wiring to the same terminal not required). Cannot be expanded with an Expansion Unit.
		16 input points (PNP)	DRT2-ID16TA-1	
		16 output points (NPN)	DRT2-OD16TA	
		16 output points (PNP)	DRT2-OD16TA-1	
		8 input points/8 output points (NPN)	DRT2-MD16TA	
		8 input points/8 output points (PNP)	DRT2-MD16TA-1	
Sensor Connector Terminals with Transistors		16 input points (NPN)	DRT2-ID16S	Use industry standard Sensor connectors.
		16 input points (PNP)	DRT2-ID16S-1	
		8 input points/8 output points (NPN)	DRT2-MD16S	
		8 input points/8 output points (PNP)	DRT2-MD16S-1	
MIL Connector Terminals with Transistors		16 input points (NPN)	DRT2-ID16ML	Connects to relay terminal using MIL cable.
		16 input points (PNP)	DRT2-ID16ML-1	
		16 output points (NPN)	DRT2-OD16ML	
		16 output points (PNP)	DRT2-OD16ML-1	
		16 input points (NPN)	DRT2-ID16MLX	A connecting cable (10 cm) is included.
		16 input points (PNP)	DRT2-ID16MLX-1	
		16 output points (NPN)	DRT2-OD16MLX	
		16 output points (PNP)	DRT2-OD16MLX-1	

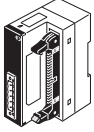
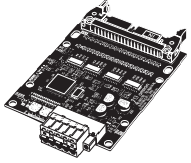
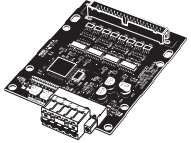
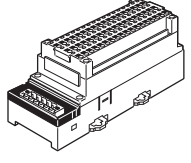
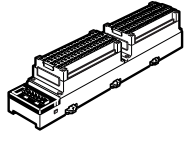
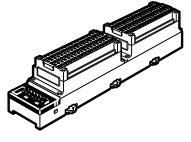
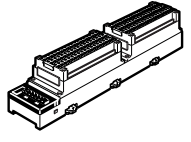
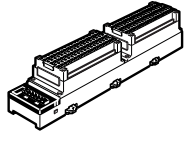
Name	Appearance	I/O points	Model number	Remarks		
MIL Connector Terminals with Transistors		32 input points (NPN)	DRT2-ID32ML	Connects to relay terminal using MIL cable.		
		32 input points (PNP)	DRT2-ID32ML-1			
		32 output points (NPN)	DRT2-OD32ML			
		32 output points (PNP)	DRT2-OD32ML-1			
		16 input points/16 output points (NPN)	DRT2-MD32ML			
		16 input points/16 output points (PNP)	DRT2-MD32ML-1			
Board MIL Connector Terminals with Transistors		32 input points (NPN)	DRT2-ID32B	MIL connectors mounted parallel to board		
		32 input points (PNP)	DRT2-ID32B-1			
		32 output points (NPN)	DRT2-OD32B			
		32 output points (PNP)	DRT2-OD32B-1			
		16 input points/16 output points (NPN)	DRT2-MD32B			
		16 input points/16 output points (PNP)	DRT2-MD32B-1			
		32 input points (NPN)	DRT2-ID32BV	MIL connectors mounted perpendicular to board		
		32 input points (PNP)	DRT2-ID32BV-1			
		32 output points (NPN)	DRT2-OD32BV			
		32 output points (PNP)	DRT2-OD32BV-1			
		16 input points/16 output points (NPN)	DRT2-MD32BV			
		16 input points/16 output points (PNP)	DRT2-MD32BV-1			
Screw-less Clamp Terminal with Transistors		16 input points (NPN)	DRT2-ID16SL	Without detection function		
		16 input points (PNP)	DRT2-ID16SL-1			
		16 output points (NPN)	DRT2-OD16SL			
		16 output points (PNP)	DRT2-OD16SL-1			
			16 input points (NPN)	DRT2-ID16SLH	With detection function	
			16 input points (PNP)	DRT2-ID16SLH-1		
			16 output points (NPN)	DRT2-OD16SLH		
			16 output points (PNP)	DRT2-OD16SLH-1		
			32 input points (NPN)	DRT2-ID32SL		Without detection function
			32 input points (PNP)	DRT2-ID32SL-1		
		32 output points (NPN)	DRT2-OD32SL			
		32 output points (PNP)	DRT2-OD32SL-1			
			16 input points/16 output points (NPN)	DRT2-MD32SL	With detection function	
			16 input points/16 output points (PNP)	DRT2-MD32SL-1		
	32 input points (NPN)		DRT2-ID32SLH			
	32 input points (PNP)		DRT2-ID32SLH-1			
	32 output points (NPN)		DRT2-OD32SLH			
	32 output points (PNP)		DRT2-OD32SLH-1			
	16 input points/16 output points (NPN)	DRT2-MD32SLH				
	16 input points/16 output points (PNP)	DRT2-MD32SLH-1				

Environment-resistive Slaves

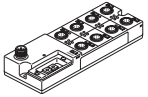
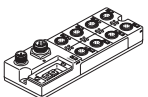
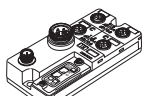
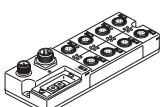
Name	Appearance	I/O points	Model number	Remarks
Environment-resistive Terminals		8 input points (NPN)	DRT2-ID08C	Waterproof, oil-proof, and spatter-proof construction (IP67).
		8 input points (PNP)	DRT2-ID08C-1	
		16 input points (NPN)	DRT2-HD16C	
		16 input points (PNP)	DRT2-HD16C-1	
		8 output points (NPN)	DRT2-OD08C	
		8 output points (PNP)	DRT2-ID08C-1	
Environment-resistive Terminals, Standard Models		4 input points (NPN)	DRT2-ID04CL	Waterproof, oil-proof, and spatter-proof construction (IP67). Not equipped with detection functions.
		4 input points (PNP)	DRT2-ID04CL-1	
		4 output points (NPN)	DRT2-OD04CL	
		4 output points (PNP)	DRT2-OD04CL-1	
		8 input points (NPN)	DRT2-ID08CL	
		8 input points (PNP)	DRT2-ID08CL-1	
		16 input points (NPN)	DRT2-HD16CL	
		16 input points (PNP)	DRT2-HD16CL-1	
		8 output points (NPN)	DRT2-OD08CL	
		8 output points (PNP)	DRT2-OD08CL-1	
		16 output points (NPN)	DRT2-WD16CL	
		16 output points (PNP)	DRT2-WD16CL-1	
		8 input points/8 output points (NPN)	DRT2-MD16CL	
		8 input points/8 output points (PNP)	DRT2-MD16CL-1	

Analog Slaves

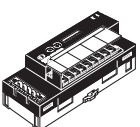
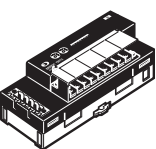
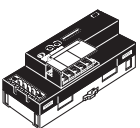
Name	Appearance	I/O points	Model number	Remarks
Analog Terminals		4 input points (0 to 5 V, 1 to 5 V, 0 to 10 V, -10 to 10 V, 0 to 20 mA, 4 to 20 mA)	DRT2-AD04	Terminal block mounted/ removed using screws. The DRT2-AD04H is a High-resolute Terminal (1/30,000 FS).
		4 input points (0 to 5 V, 1 to 5 V, 0 to 10 V, 0 to 20 mA, 4 to 20 mA)	DRT2-AD04H	
		2 output points (0 to 5 V, 1 to 5 V, 0 to 10 V, -10 to 10 V, 0 to 20 mA, 4 to 20 mA)	DRT2-DA02	

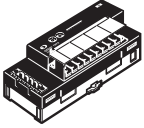
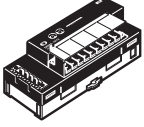
Name	Appearance	I/O points	Model number	Remarks
Temperature Input Terminals		4 input points (Switchable between R, S, K1, K2, J1, J1, T, E, B, N, L1, L2, U, W, and PL2.)	DRT2-TS04T	Thermocouple input
		4 input points (Switchable between PT, JPT, PT2, and JPT2.)	DRT2-TS04P	Platinum resistance thermometer input

1-2-3-3 MULTIPLE I/O TERMINAL Units

Unit		I/O points	Words allocated in PLC memory		I/O connections	Unit power supply voltage	Installation	Model number	Remarks
			Input	Output					
Communications Unit		None	Two status words	0 words	None	24 V DC (supplied from outside)	DIN track	DRT1-COM	---
Basic I/O Units	Transistor Input Units	16 input points	1 word	0 words	M3 terminal block			GT1-ID16	NPN
		16 input points	1 word	0 words	Connector (made by MOLEX)	GT1-ID16-1	PNP		
		16 input points	1 word	0 words	Connector (made by FUJITSU)	GT1-ID16MX	NPN		
		16 input points	1 word	0 words	Connector (made by FUJITSU)	GT1-ID16MX-1	PNP		
		16 input points	1 word	0 words	Connector (made by FUJITSU)	GT1-ID16ML	NPN		
		16 input points	1 word	0 words	Connector (made by FUJITSU)	GT1-ID16ML-1	PNP		
		16 input points	1 word	0 words	Connector (D-sub, 25 pin)	GT1-ID16DS	NPN		
	32 input points	2 words	0 words	High-density connector (made by FUJITSU)	GT1-ID16DS-1	PNP			
	Transistor Output Units	16 output points	0 words	1 word	M3 terminal block	GT1-ID32ML	NPN		
		16 output points	0 words	1 word	Connector (made by MOLEX)	GT1-ID32ML-1	PNP		
		16 output points	0 words	1 word	Connector (made by FUJITSU)	GT1-OD16	NPN		
		16 output points	0 words	1 word	Connector (made by FUJITSU)	GT1-OD16-1	PNP		
		16 output points	0 words	1 word	Connector (made by FUJITSU)	GT1-OD16MX	NPN		
		16 output points	0 words	1 word	Connector (made by FUJITSU)	GT1-OD16MX-1	PNP		
16 output points		0 words	1 word	Connector (D-sub, 25 pin)	GT1-OD16ML	NPN			
32 output points	0 words	2 words	High-density connector (made by FUJITSU)	GT1-OD16ML-1	PNP				
Relay Output Units	8 output points	0 words	1 word	M3 terminal block	GT1-OD16DS	NPN			
	16 output points	0 words	1 word	M3 terminal block	GT1-OD16DS-1	PNP			
							GT1-OD32ML	NPN	
							GT1-OD32ML-1	PNP	
							GT1-OD31ML-1	PNP	
							GT1-ROP08	---	
							GT1-ROS16	---	

Unit		I/O points	Words allocated in PLC memory		I/O connections	Unit power supply voltage	Installation	Model number	Remarks	
			Input	Output						
Special I/O Units (See note.)	Analog Input Units	4 inputs	4 words	0 words	M3 terminal block	24 V DC (supplied from outside)	DIN track	GT1-AD04	Inputs: 4 to 20 mA, 0 to 20 mA, 0 to 5 V, 1 to 5 V, 0 to 10 V, -10 to 10 V	
		8 inputs	8 words	0 words	Connector (made by MOLEX)			GT1-AD08MX		
	Analog Output Units	4 outputs	0 words	4 words	M3 terminal block			GT1-DA04		Outputs: 4 to 20 mA, 0 to 5 V, 1 to 5 V, 0 to 10 V, -10 to 10 V
		4 outputs	0 words	4 words	Connector (made by MOLEX)			GT1-DA04MX		
	Temperature Input Unit	4 inputs	4 or 8 words (varies with data format)	0 words	M3 terminal block			GT1-TS04T		Sensor types: R, S, K, J, T, B, L
								GT1-TS04P		
	Counter Unit	1 input	3 words	3 words	M3 terminal block			GT1-CT01		1 external input 2 external outputs

Note The Analog Input Units, Analog Output Units, Temperature Input Units, and Counter Units belong to a group called Special I/O Units. The front-panel indicators and other parts of Special I/O Units differ from those of other I/O Units.

One I/O Unit Connecting Cable (cable length 40 mm) is included with each I/O Unit. One end connector is attached to the Communications Unit.

I/O Unit Connecting Cables with a cable lengths of 0.1, 0.3, 0.4, 0.6, and 1 m (GCN1-010/030/040/060/100) are sold separately (see below).

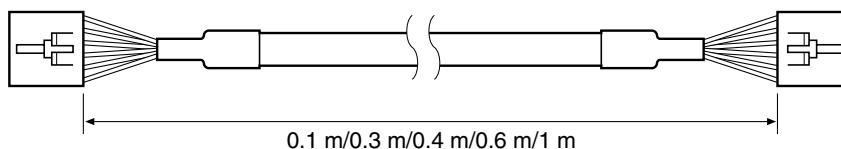

1-2-4 DeviceNet Configurator

The Configurator is a software configuration tool for the DeviceNet network. The Configurator can be used to set parameters (the scan list) and monitor operation in OMRON Master Units. The Configurator can also be used to set parameters in OMRON and other companies' Slaves.

Product name	Model	Components	Network connection to computer	Applicable computer	OS
DeviceNet Configurator (Ver. 2)	WS02-CFDC1-J	Installation disk (CD-ROM)	Any of the following: <ul style="list-style-type: none"> Through an Ethernet Unit Serial connection Dedicated PCI Board PCMCIA Card (See the table below.)	IBM PC/AT or compatible	Windows 95, 98, Me, NT4.0, 2000, or XP

Note The following Boards and Cards can be used.

Model	Components	Applicable computer	OS
3G8F7-DRM21	Dedicated PCI Board (Configurator not included.)	IBM PC/AT or compatible	Windows 95, 98, Me, NT 4.0, 2000, or XP
3G8E2-DRM21-V1	Dedicated PCMCIA Card with DeviceNet Configurator		Windows 98, Me, NT 4.0, 2000, or XP

1-3 Communications Specifications

Item	Specifications			
Communications protocol	DeviceNet			
Connection methods (See note 1.)	Multi-drop and T-branch connections can be combined (for trunk and branch lines)			
Baud rate	500 Kbps, 250 Kbps, or 125 Kbps			
Communications media	Special 5-wire cables (2 signal lines, 2 power lines, 1 shield line) Special 4-wire flat cables (2 signal lines, 2 power lines)			
Communications distances for special 5-wire cables	Baud rate	Network length	Branch line length	Total branch line length
	500 kbps	100 m max.	6 m max.	39 m max.
	250 kbps	250 m max. (See note 2.)	6 m max.	78 m max.
Communications distances for special 4-wire flat cables	125 kbps	500 m max. (See note 2.)	6 m max.	156 m max.
	Baud rate	Network length	Branch line length	Total branch line length
	500 kbps	75 m max.	6 m max.	35 m max.
Communications power supply	250 kbps	150 m max.	6 m max.	48 m max.
	125 kbps	265 m max.	6 m max.	135 m max.
Max. number of nodes	24 V DC supplied externally			
	64 nodes (including Masters, Slaves, and Configurator)			

- Note**
1. Terminators are required at both ends of trunk line.
 2. Indicates the maximum network length when thick cables are used. Reduce the network length to 100 m max. when using thin cables.

1-4 Basic Operating Procedures

1-4-1 DeviceNet Network Configuration and Wiring

- 1,2,3...
1. Determine the Baud Rate Required for the Application
Refer to the section on communications timing in the Master Unit Manual (see below) to determine the appropriate responsiveness and baud rate for your application.
 - CS/CJ Series DeviceNet Operation Manual (W380)
 - CVM1/CV DeviceNet Master Unit, C200HX/HG/HE DeviceNet Master Unit Operation Manual (W379)
 - DeviceNet PCI Board Operation Manual (W381)
 2. Determine the Cable Layout and Cable Lengths to All Nodes
Verify that the planned configuration is within the network configuration specifications.
 - Refer to *2-1 Network Configuration Overview* for details on the network configuration.
 - Refer to *2-2 Network Configuration* for configuration precautions.
 3. Determine the Communications Power Supply Method
When planning the communications power supply layout, verify that the voltage drop over the communications cables is within specifications.
 - Refer to *SECTION 3 Communications Power Supply Methods* for details.
 - In particular, refer to *3-2-1 Communications Power Supply* for a flow-chart that will guide you through the selection process.
 4. Select the Required Devices
 - Refer to the device manuals when making arrangements for the Masters, Slaves, and the Configurator.
 - Refer to *2-3 Cables, Connectors, and Related Devices* for details on other related devices.
 5. Purchase the Required Equipment
 6. Construct the Network
Construct the network using recommended wiring and noise-control techniques.
 - Refer to *2-4 Wiring Methods* for details on wiring.
 - Refer to *2-5 Minimizing Noise in the Network* for details on noise-control techniques.
 - Refer to *2-2 Network Configuration the Network Configuration* for other precautions.

1-4-2 Network Start-up Procedure

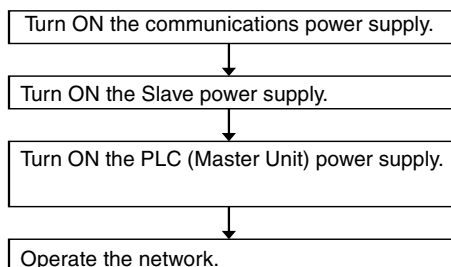

- Note**
1. All three power supplies can be turned ON simultaneously. It is also acceptable to turn ON the communications and Slave power supplies or the Slave and PLC power supplies simultaneously.
 2. Slaves may not be recognized if the communications power supply is turned ON after the Slave power supply.
 3. Always operate the network with the scan list enabled in the Master Unit. When the scan list is enabled, the user can check whether Slaves are participating in the network from the PLC and verify that the DeviceNet network is communicating normally.

SECTION 2

Network Configuration and Wiring

This section explains how to plan the DeviceNet Network configuration and wire the Network.

2-1	Network Configuration Overview	22
2-1-1	Network Configuration	22
2-1-2	Example Network Configuration	25
2-1-3	Network Configuration Restrictions	26
2-1-4	Connections	28
2-1-5	Detailed Connection Patterns	30
2-2	Network Configuration	32
2-2-1	Compatible Cables	32
2-2-2	Trunk Lines and Branch Lines	33
2-2-3	Proper Cable Usage	37
2-2-4	Determining the Location of the Master	39
2-2-5	T-branch Tap Connections	40
2-2-6	Connecting Devices other than DeviceNet Products	40
2-2-7	Connecting Terminators (Terminating Resistors)	40
2-2-8	Using Crimp Terminals	41
2-2-9	Sharing the Communications and Internal Circuit Power Supply	41
2-2-10	Grounding Methods	42
2-2-11	Allocating Node Numbers	43
2-3	Cables, Connectors, and Related Devices	43
2-3-1	Communications Cables	43
2-3-2	Connectors for Node Connections	48
2-3-3	Screwdrivers for Connector Screws	52
2-3-4	T-branch Taps	52
2-3-5	Shielded T-branch Connectors	57
2-3-7	Power Supply Tap	59
2-3-8	Terminating Resistors	60
2-3-9	Communications Power Supply	61
2-4	Wiring Methods	62
2-4-1	Wiring and Installing Standard Connectors	62
2-4-2	Attaching Flat Cable Connectors	67
2-4-3	Attaching Shielded Connectors	68
2-4-4	Connecting to T-branch Taps and Nodes	69
2-4-5	Flat Cable I (Standard)	70
2-4-6	Connecting Shielded (Environment-resistive) Cables	76
2-4-7	Wiring the Communications Power Supply	76
2-4-8	Connecting the Terminating Resistors (Terminators)	78
2-4-9	Grounding the Network	80
2-5	Minimizing Noise in the Network	82
2-5-1	Precautions to Prevent Noise	82
2-5-2	Correcting Malfunctions due to Noise	84
2-6	Operational Checklist	85

2-1 Network Configuration Overview

2-1-1 Network Configuration

The DeviceNet Network can be configured as shown in the following diagrams.

Network with General-purpose Slaves Only

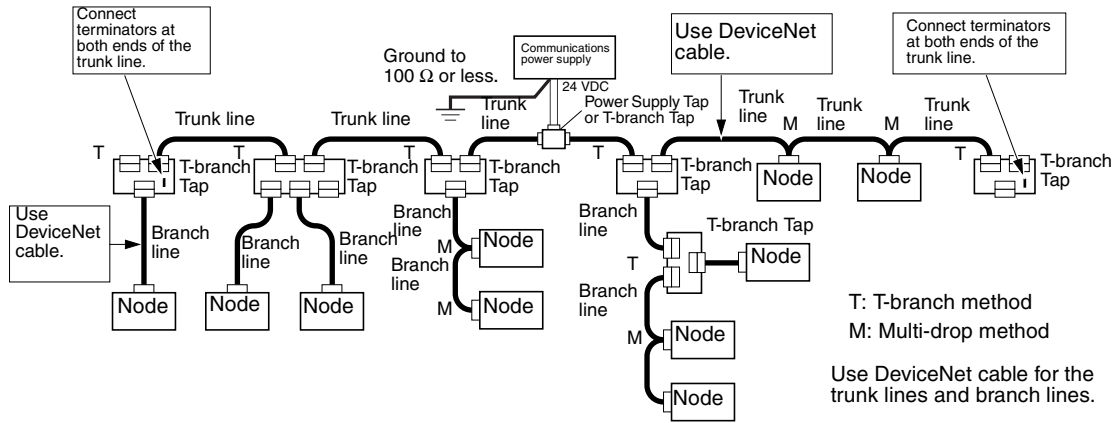

Network with General-purpose and Environment-resistive Slaves

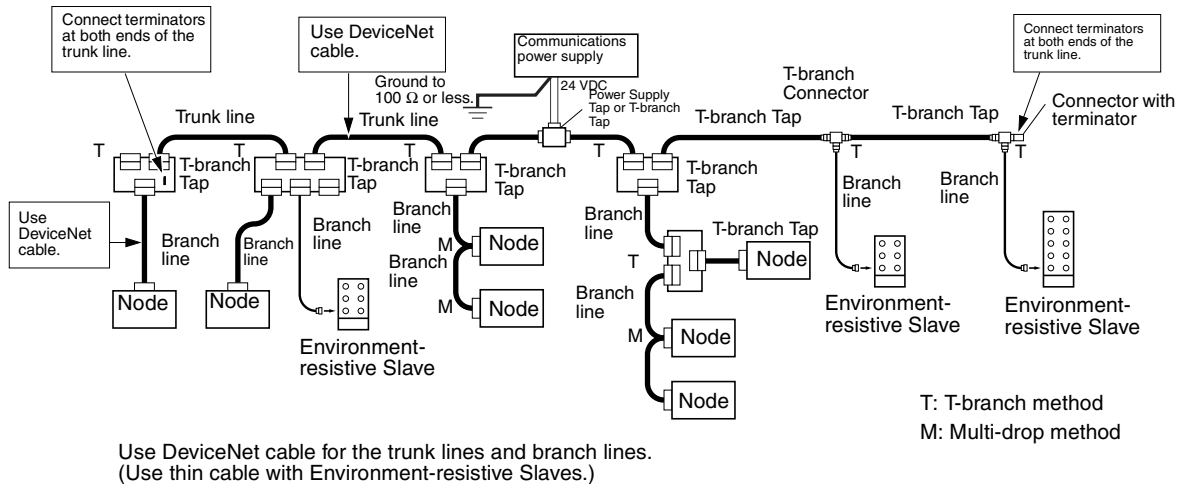

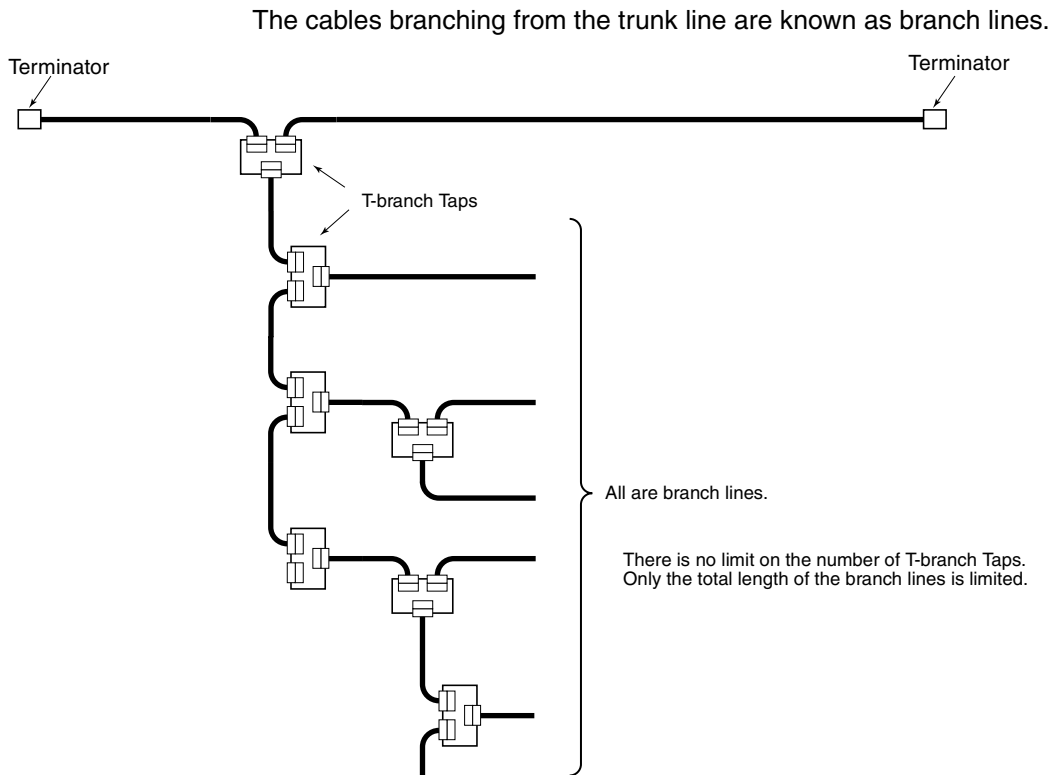

DeviceNet cables (Special Thin/Thick Cables and Special Flat Cables) are used for both the trunk and branch lines in DeviceNet communications. Special Thin/Thick Cables include Special Thin Cables and Special Thick Cables.

Note With Environment-resistive Slaves (Slaves with a round connector), special OMRON cable with a shielded, waterproof connector is used for both the trunk and branch lines.

Terminating Resistors (Terminators)

Always connect Terminating Resistors at both ends of the network to reduce signal reflection and stabilize communications. The cable that stretches from one terminator to the other is the trunk line. Determine which cable will be the trunk line based on the network's configuration.

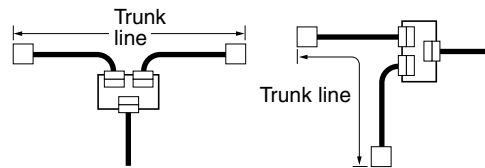

There are two main kinds of Terminating Resistors available, one for the T-branch Tap/Power Supply Tap and one for a Terminal Block. There are also connectors with terminating resistance (male and female) that connect to the Shielded T-branch Connector used with Environment-resistive Slaves.

Note When using a Terminal-block type Terminating Resistor, a DeviceNet cable must be used for the cable connecting the Terminating Resistor.

Connection Methods

Two methods can be used to connect DeviceNet nodes: The T-branch method and the multi-drop method. With the T-branch method, the node is connected to a branch line created with a T-branch Tap or Shielded T-branch Connector.

With the multi-drop method, the node is directly connected to the trunk line or the branch line.

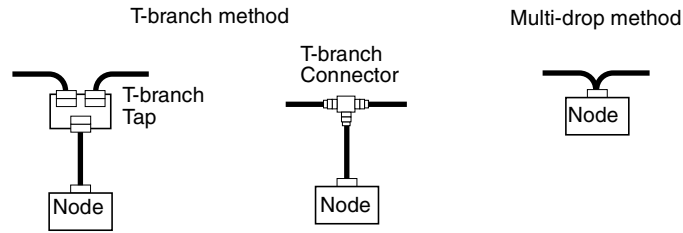

Secondary branches can be made from a branch line. There is no limit on the number of T-branch Taps and multi-drop connections in the network.

Note Both of these connection methods can be used in the same Network, as shown in the example above.

Communications Power Supply

To use DeviceNet, communications power (24 VDC) must be supplied to each node through DeviceNet cable. Refer to 2-2-9 *Sharing the Communications and Internal Circuit Power Supply* for details.

Ground

Ground the entire network at just one point. Ground at 100 Ω or less.

2-1-2 Example Network Configuration

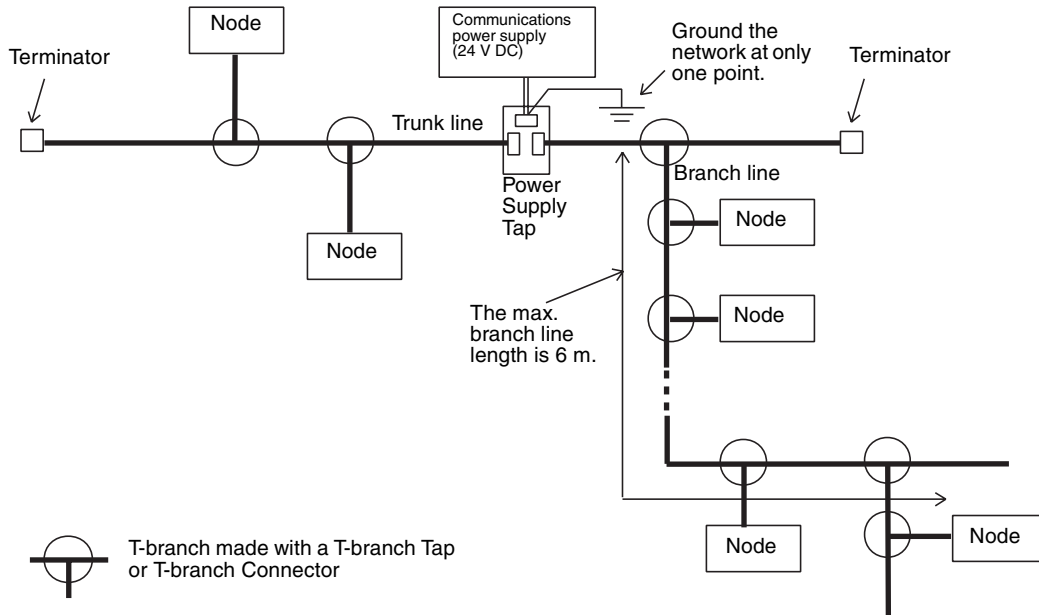

2-1-3 Network Configuration Restrictions

The following table shows the maximum cable lengths and maximum current for the various cable type/baud rate combinations.

Cable type	Baud rate	Max. network length	Branch line length	Total branch line length	Current capacity
Thick cable	500 kbps	100 m	6 m max.	39 m	8 A
	250 kbps	250 m		78 m	
	125 kbps	500 m		156 m	
Thin cable	500 kbps	100 m		39 m	3 A
	250 kbps	100 m		78 m	
	125 kbps	100 m		156 m	
Flat cable	500 kbps	75 m	35 m	5 A	
	250 kbps	150 m	48 m		
	125 kbps	265 m	135 m		

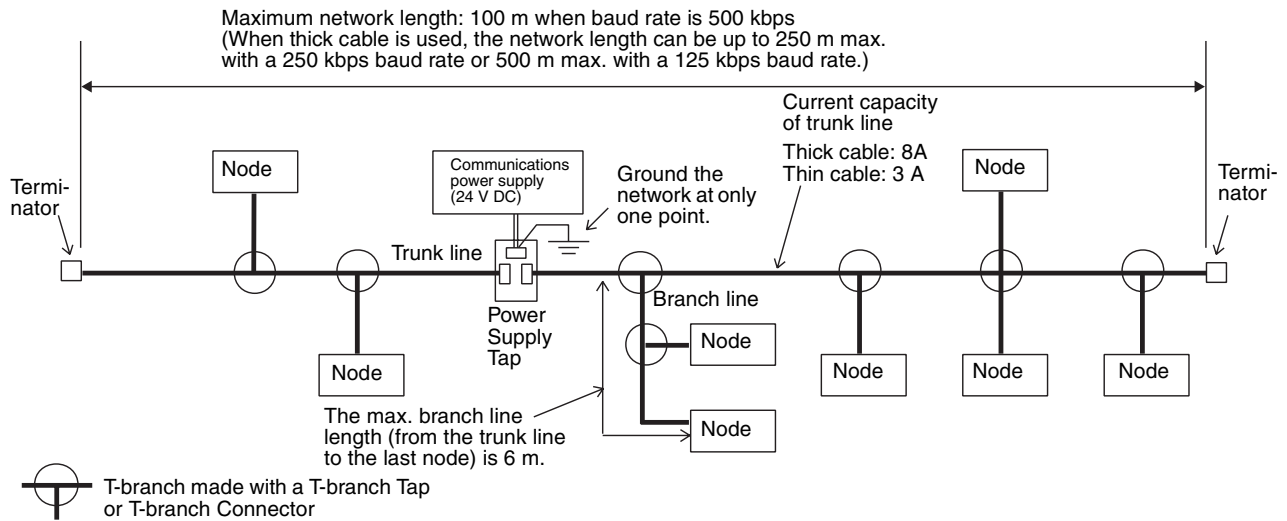

Definition of the Maximum Network Length

The maximum network length is the distance between the two nodes that are farthest apart or the distance between the terminators, whichever is greater. (The trunk line length and maximum network length are not always the same.)

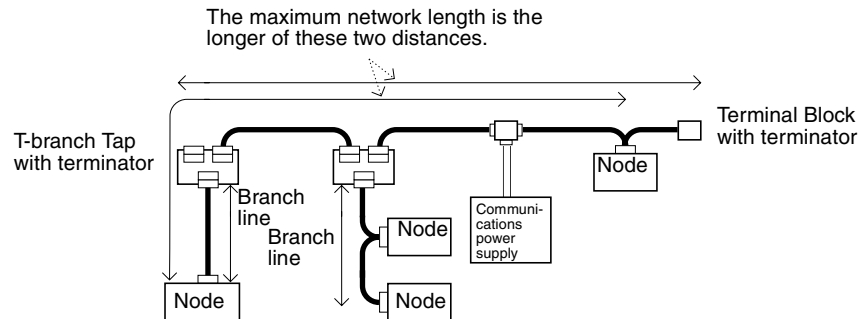

Definition of Branch Line Length

A branch line cannot be longer than 6 m. The branch line length is the distance from the point in the trunk line where the original branch was made to the end of the branch.

Note The branch line length is not just the distance between T-branch Taps or the distance from a node to a T-branch Tap on the branch line; it is the total distance from the trunk line to the end of the branch.

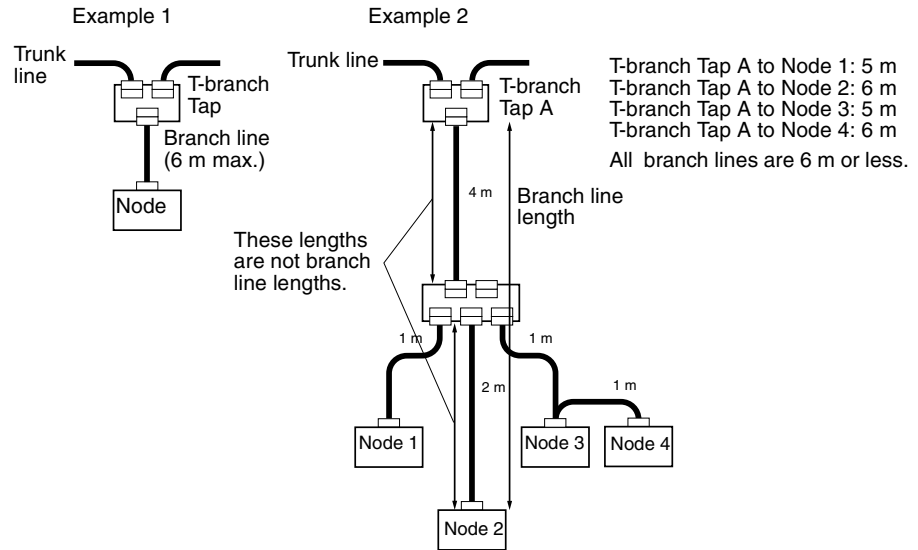

Definition of Total Branch Line Length

The total branch line length is the sum of all branch lines in the network.

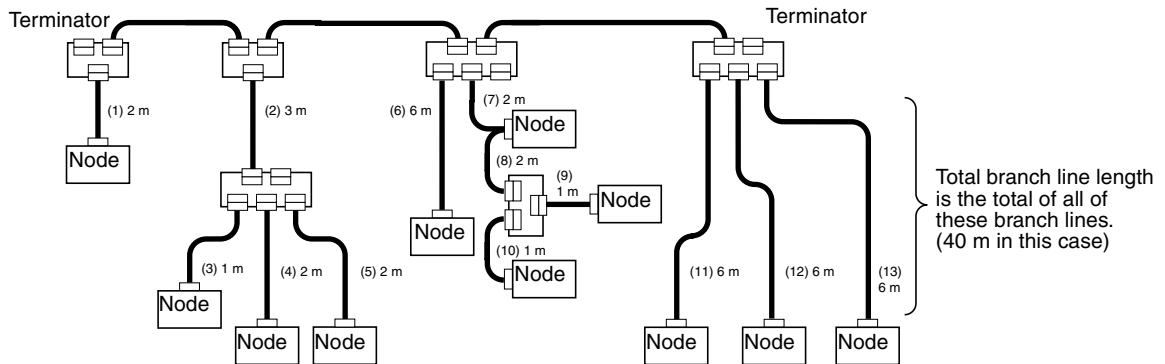

In the example above, the total branch line length is 40 m. The maximum total branch line length is 39 m for 500-kbps communications, so a baud rate of 250 kbps or 125 kbps must be used in this network.

$$\begin{aligned}
 (\text{Total branch line length}) &= (1) + (2) + (3) + (4) + (5) + (6) + (7) + (8) + (9) + (10) + (11) + (12) + (13) \\
 &= 2 + 3 + 1 + 2 + 2 + 6 + 2 + 2 + 1 + 1 + 6 + 6 + 6 \\
 &= 40 \text{ m}
 \end{aligned}$$

Current Capacities of the Cables

The current capacity of the trunk line is 8 A when a Thick Cable is used, 3 A when a Thin Cable is used, and 5 A when a Special Flat Cable is used. To estimate the current through the trunk line, add up the current consumption of all the nodes in each direction from the communications power supply. The total current consumption must be no more than 8 A when a Thick Cable is used, 3 A when a Thin Cable is used, and 5 A when a Special Flat Cable is used.

With branch lines, the current carrying capacity of the branch line is inversely proportional to the length of the line. The current capacity of a branch line is 4.57/L (A) where L is the length of the branch line (m). Verify that the total cur-

rent consumption of the nodes in the branch is less than $4.57/L$ or 3 A, whichever is lower.

Refer to *SECTION 3 Communications Power Supply Methods* for more details.

- Note**
1. Always use DeviceNet cables.
 2. Always connect terminators at both ends of the trunk line.
 3. Do not install devices other than DeviceNet devices (e.g., a lightning arrester) in the communications line. Devices other than DeviceNet-compatible devices can cause effects such as signal reflection and interfere with DeviceNet communications.

2-1-4 Connections

Branching Patterns

Branching from the Trunk Line

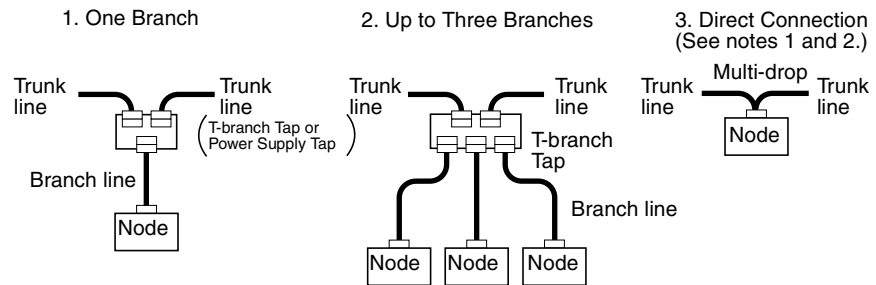

- Note**
1. The direct multi-drop connection cannot be used for Environment-resistive Slaves.
 2. If thick cable is being used, a multi-drop connector must be used to make the direct multi-drop connection. (If thick cable is being used, the regular COMBICON connector can be used to make a multi-drop connection.)

Branching from a Branch Line

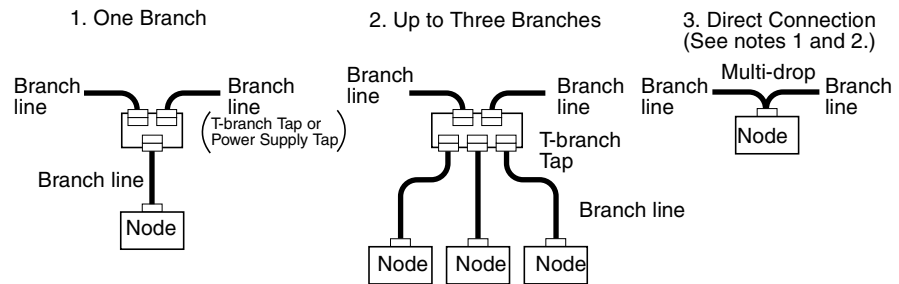

- Note**
1. The direct multi-drop connection cannot be used for Environment-resistive Slaves.
 2. If thick cable is being used, a multi-drop connector must be used to make the direct multi-drop connection. (If thick cable is being used, the regular COMBICON connector can be used to make a multi-drop connection.)

The various connection methods can be combined on the same network, as shown in the following diagram. There is no particular limit to the number of

nodes that can be connected onto a single branch line, except for the limit on the total number of nodes (63 max.) in the network.

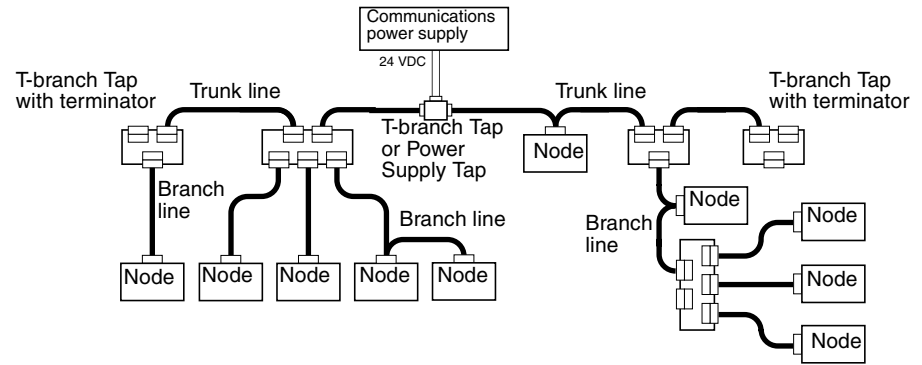

Note Environment-resistive Slaves cannot be connected directly to the trunk line with the multi-drop method. General-purpose and Special Slaves can be connected directly to the trunk line with the multi-drop method, but it is easier to connect a node to a branch line.

2-1-5 Detailed Connection Patterns

Branches

T-branch Method

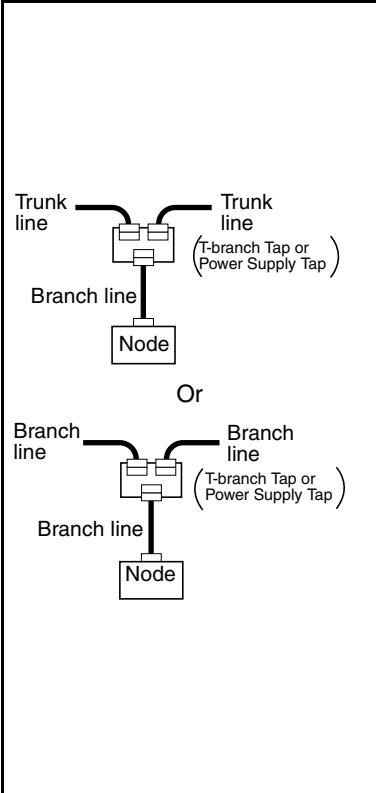
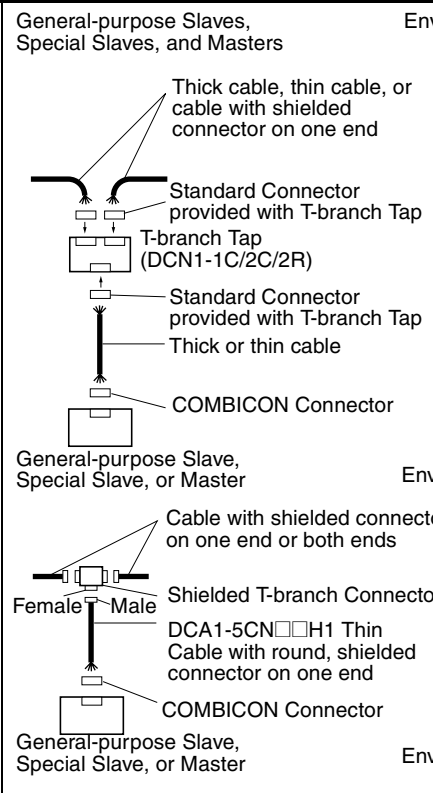
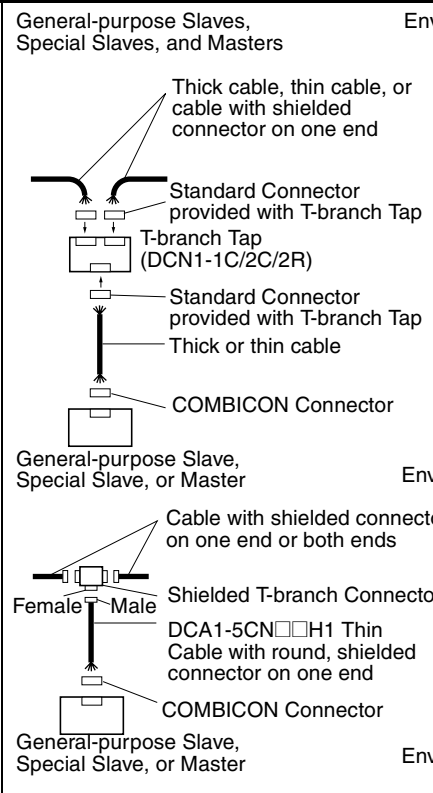
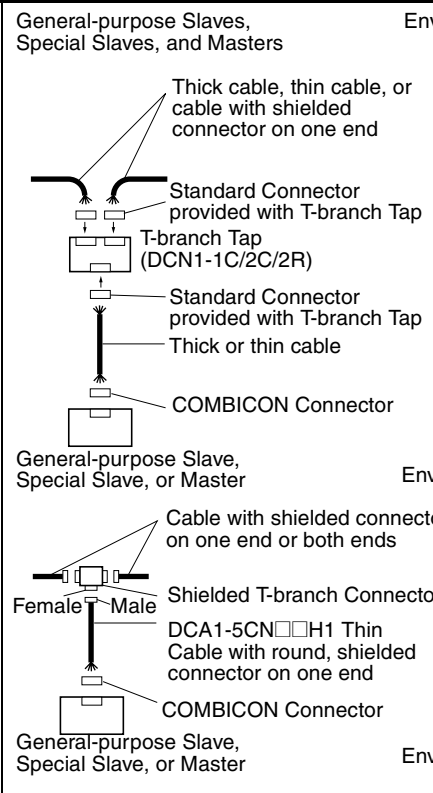
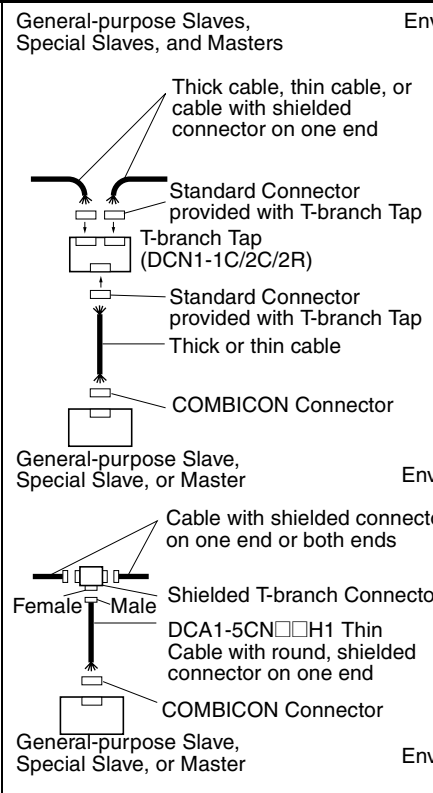
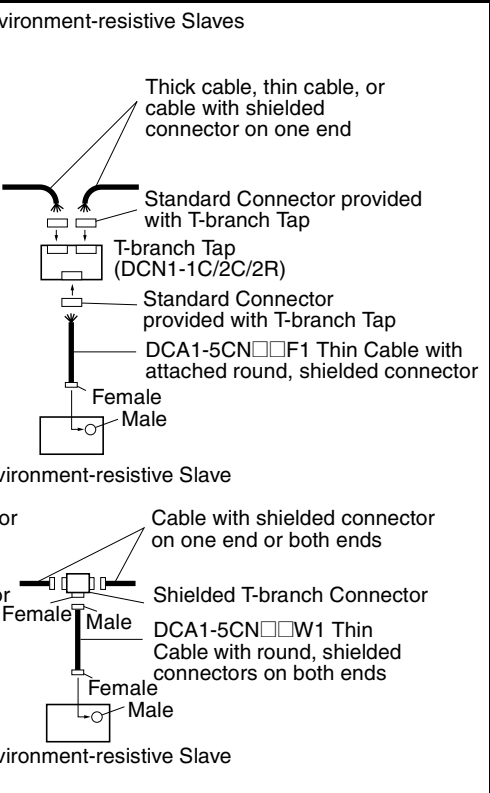
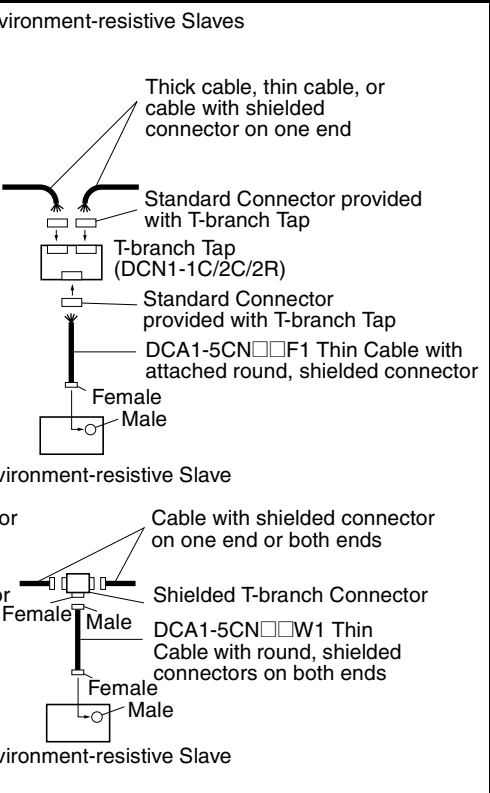
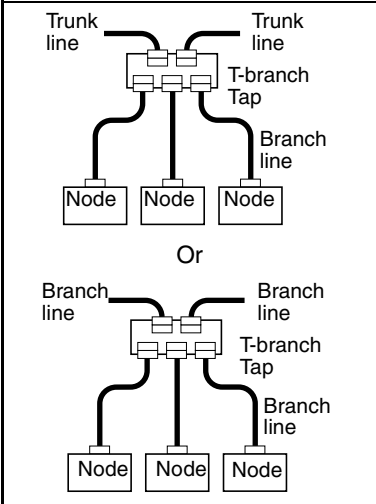
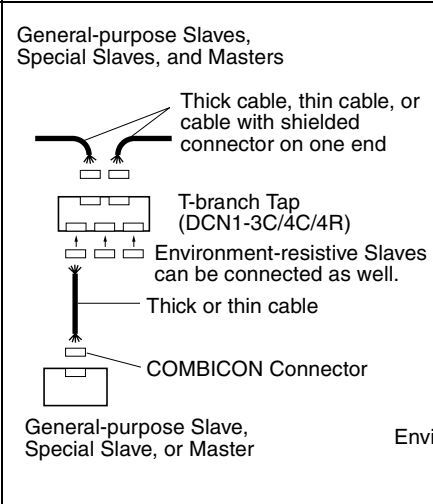
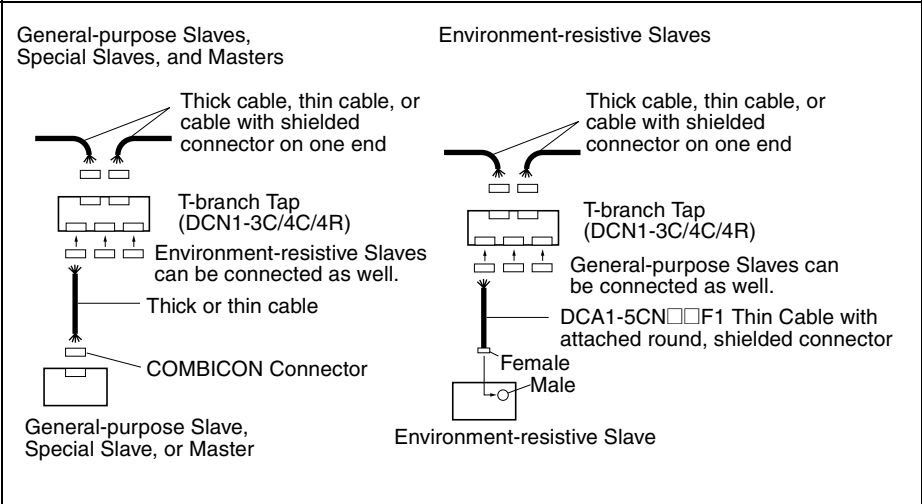
Connection pattern	Connection method	
	<p>General-purpose Slaves, Special Slaves, and Masters</p>  <p>Environment-resistive Slaves</p>  <p>General-purpose Slave, Special Slave, or Master</p>  <p>Environment-resistive Slave</p>  <p>General-purpose Slave, Special Slave, or Master</p> <p>Environment-resistive Slave</p>	<p>Environment-resistive Slaves</p>  <p>Environment-resistive Slaves</p>  <p>Environment-resistive Slave</p>
	<p>General-purpose Slaves, Special Slaves, and Masters</p>  <p>Environment-resistive Slaves</p>  <p>Environment-resistive Slave</p>	

Note The cables with a shielded connector on one or both ends have a round communications connector on one or both ends.

Multi-drop Method

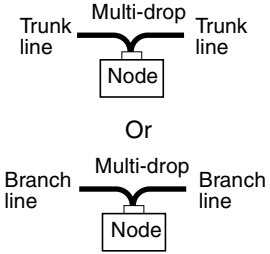
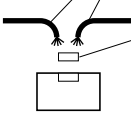
Connection pattern	Connection method	
	<p>General-purpose Slaves, Special Slaves, and Masters</p>  <p>Thick cable, thin cable, or cable with shielded connector on one end</p> <p>With thick cable, a multi-drop connector must be used. With thin cable, a COMBICON connector or multi-drop connector can be used.</p>	<p>Environment-resistive Slaves</p> <p>Multi-drop connections are not allowed.</p>

Communications Power Supply

Use either of the methods shown below to connect the 24-V DC communications power supply to the trunk line. Refer to *2-4-7 Wiring the Communications Power Supply* for wiring details.

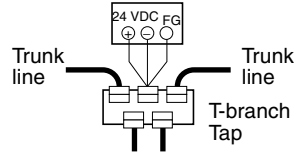
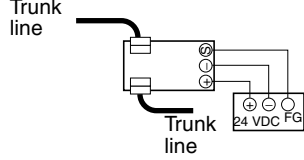
Connecting to a T-branch Tap (See note 1.)	Connecting to a Power Supply Tap (See note 2.)
	

- Note**
1. The communications power supply can be connected through a T-branch Tap only when there is just one communications power supply in the network and the total current consumption is 5 A or less.
 2. The communications power supply can be connected through a Power Supply Tap even if there is more than one communications power supply in the network or the total current consumption exceeds 5 A.

When grounding the communications power supply to an acceptable ground (100 Ω or less), connect the communications power supply's V- and FG terminals.

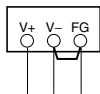

If an acceptable ground is not available, connecting the V- and FG terminals may introduce noise into the network so we recommend against connecting the terminals.

Use a separate power supply for DeviceNet communications. The power supply can be shared, however, if noise interference is not generated by the internal circuit power supply, Sensor power supply, or other source.

Terminating Resistors (Terminators)

Use the methods shown below to connect the Terminating Resistors to the trunk line. Refer to 2-4-8 *Connecting the Terminating Resistors (Terminators)* for wiring details.

Connecting to a T-branch Tap or Power Supply Tap (See note 1.)	Connecting to a Terminal Block (See note 2.)	Connecting to a T-branch Connector (See note 3.)	Connecting a Terminating Resistor to a Flat Connector Socket (See note 4.)

- Note**
1. Connect a Terminating Resistor to the Tap when there is a T-branch Tap or Power Supply Tap at the end of the trunk line.
 2. The Terminal-block Terminating Resistor method can be used when a node is connected at the end of the trunk line with the multi-drop connection method.
 3. Use this method when there is an Environment-resistive Slave at the end of the trunk line.
 4. Use this method when using Flat Cable.

Ground

Use any one of the methods shown below to ground the network by connecting the cable's shielding to an acceptable ground (100 Ω or less.) Ground the network at one point only.

Refer to 2-4-9 *Grounding the Network* for wiring details.

Grounding a Power Supply Tap	Grounding a Connector of a T-branch Tap or Node	Grounding an Unused T-branch Tap Connector

2-2 Network Configuration

2-2-1 Compatible Cables

Cable Requirements

Always use DeviceNet cables that meet all DeviceNet specifications. The Network may not operate properly if other cable is used.

Cable type	OMRON model number
Thick Cable	DCA2-5C10
Thin Cable	DCA1-5C10
Flat Cable	DCA4-4F10

Refer to the home page of the ODVA for information on DeviceNet cables other than the ones listed above.

<http://www.odva.org/>

DeviceNet Cables for Moving Applications

There are DeviceNet cables available for special applications such as moving equipment. Several companies manufacture DeviceNet cables for moving applications and their contact information is available at the home page of the ODVA.

<http://www.odva.org/>

2-2-2 Trunk Lines and Branch Lines

Description of Trunk and Branch Lines

The DeviceNet network is made up of a trunk line and branch lines. The trunk line is the main line in the network and it is terminated at both ends by Terminating Resistors.

Thick, thin, and flat cable can be used for both trunk and branch lines.

Cable type	Advantages	Disadvantages
Thick cable	<ul style="list-style-type: none"> • Can be used for long distances. • Higher current capacity (8 A) 	<ul style="list-style-type: none"> • Stiff and difficult to bend
Thin cable	<ul style="list-style-type: none"> • Flexible (Can be used in tight spaces.) 	<ul style="list-style-type: none"> • Lower current capacity (3 A) • Not suitable for long distances
Flat cable	<ul style="list-style-type: none"> • Branching and extending cables is simpler. 	<ul style="list-style-type: none"> • The maximum network length and current capacity are somewhere between those of Thick and Thin Cable.

There is no limit on the number of nodes that can be connected on a branch line, although the total number of node in the network is limited. Also, there is no limit on the number of sub-branches that can be drawn from a branch line.

These features allow branches to extend from the trunk line like the branches of a tree, although the length of branches and total branch line length cannot be too long.

Branch Line Length

Branch lines can be up to 6 m long.

The branch line length is the distance from the point in the trunk line where the original branch was made to the end of the branch. (The branch line length is not just the distance between T-branch Taps or the distance from a T-branch Tap on the branch line to a node; it is the total distance from the trunk line to the end of the branch.)

The branch line length is limited to 6 m in all cases.

Baud rate	Cable type	Branch line length
500 kbps	Thick cable	6 m max. (the same in all cases)
	Thin cable	
	Flat cable	
250 kbps	Thick cable	
	Thin cable	
	Flat cable	
125 kbps	Thick cable	
	Thin cable	
	Flat cable	

Even if all branch lines are less than 6 m, the network will not operate properly if the total branch line length exceeds the maximum allowed (39 m at a baud rate of 500 kbps) or the total network length (distance between the terminators or most distant nodes) exceeds the maximum allowed. An incorrectly

configured network will have recurring communications errors, such as remote I/O communications errors and transmission timeouts.

Total Branch Line Length

The total branch line length is the sum of the lengths of all branch lines in the network. The maximum total branch line length depends upon the baud rate, as shown in the following table.

- Special Thin/Thick Cable

Baud rate	Total branch line length
500 kbps	39 m max.
250 kbps	78 m max.
125 kbps	156 m max.

- Special Flat Cable

Baud rate	Total branch line length
500 kbps	35 m max.
250 kbps	48 m max.
125 kbps	135 m max.

Maximum Network Length

The maximum network length is the distance between the two nodes that are farthest apart or the distance between the terminators, whichever is greater. (The trunk line length and max. network length are not always the same.)

The maximum network length depends upon the baud rate and cable type, as shown in the following table.

- Special Thin/Thick Cable

Baud rate	Cable type	Total branch line length
500 kbps	Thick cable	100 m
	Thin cable	
250 kbps	Thick cable	250 m
	Thin cable	100 m
125 kbps	Thick cable	500 m
	Thin cable	100 m

- Special Flat Cable

Baud rate	Total branch line length
500 kbps	75 m max.
250 kbps	150 m max.
125 kbps	265 m max.

Maximum Current Capacity

The maximum current capacity of a line depends on the cable type and the function of the line (trunk or branch line). When planning the network configuration, consider the type of cable being used, position of each device, and each device’s current consumption.

• DeviceNet Cable

Line	Cable type	Maximum current capacity
Trunk	Thick cable	8 A
	Thin cable	3 A
	Flat cable	5 A
Branch	Thick or thin cable	0.75 to 3 A The current capacity (A) of a branch line is $4.57/L$ (up to 3 A) where L is the length (m) of the branch line.

A Simple Way to Reduce Total Branch Line Length

It can be time-consuming to calculate the total branch line length and fairly difficult to meet the conditions that individual branch lines do not exceed 6 m and the total branch line length does not exceed 39 m (with a baud rate of 500 kbps.) A common cause of long branch lines and excessive total branch line length is using a straight trunk line, as shown in the following diagram.

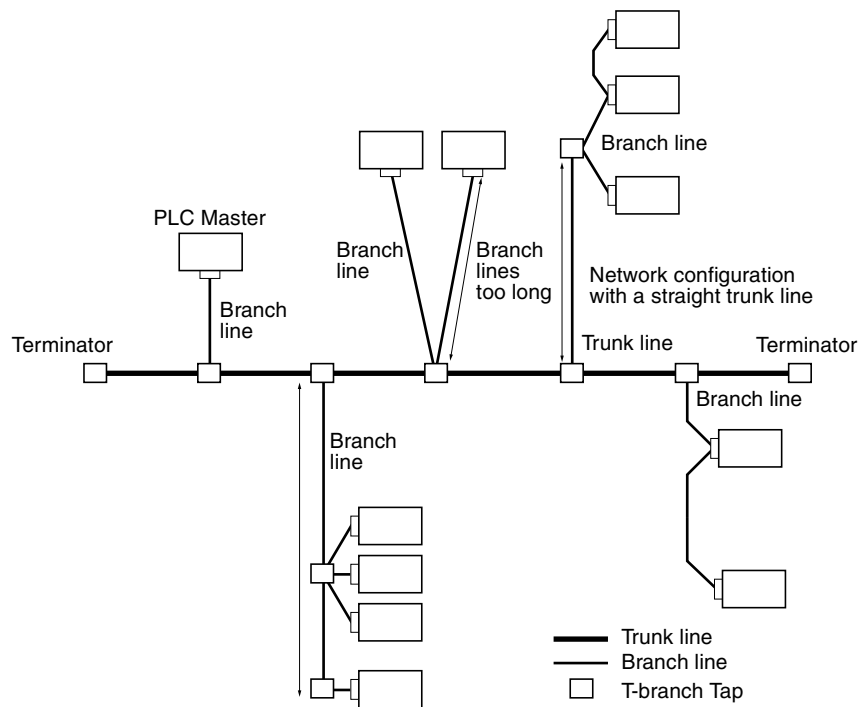

The branch line lengths can be reduced significantly by redirecting the trunk line at each node rather than using a straight trunk line. While this configuration reduces branch line lengths, it will increase the maximum network length (distance between the terminators or the nodes that are farthest apart). Verify

that the maximum network length is within specifications, e.g., 100 m when the baud rate is 500 kbps.

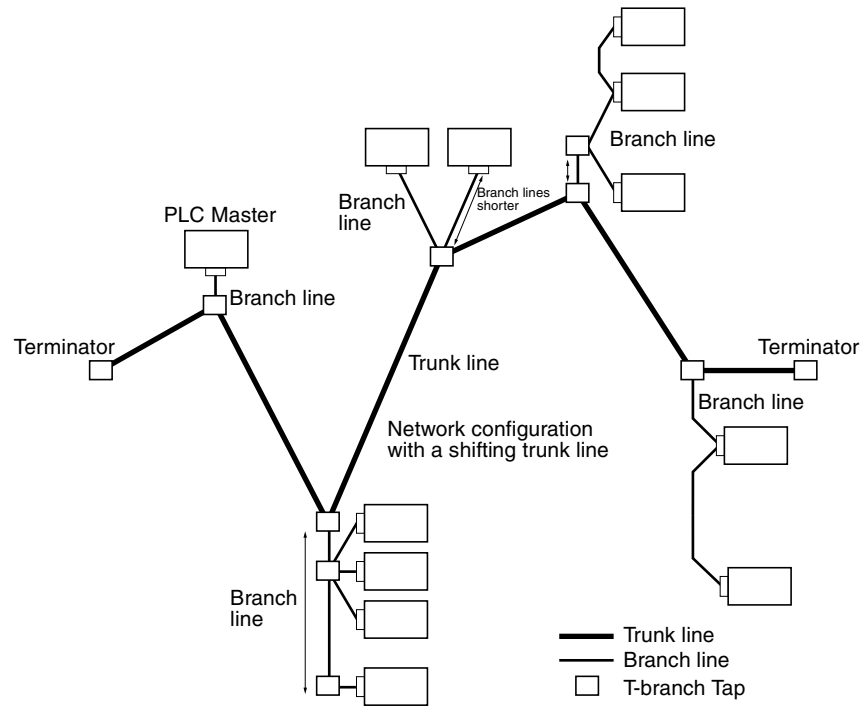

Selecting the Trunk Line

We recommend identifying the trunk line based on the control panels, such as the line between control panels or the line within a control panel.

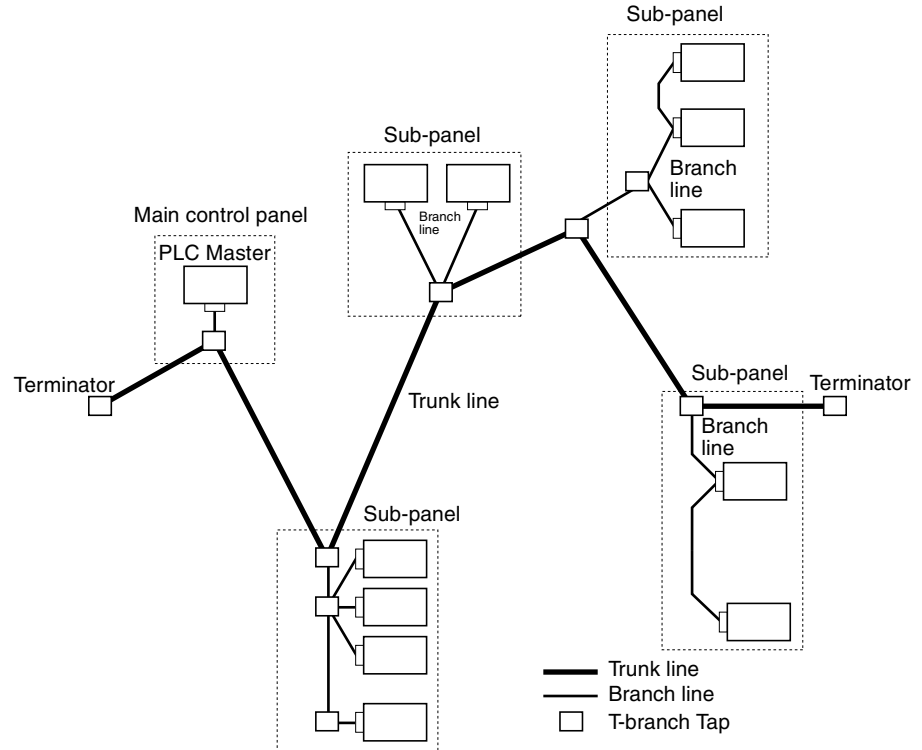

2-2-3 Proper Cable Usage

The following table shows the limitations of the thin and thick cables.

Cable type	Baud rate	Max. network length	Branch line length	Total branch line length	Current capacity
Thick cable	500 kbps	100 m	6 m max.	39 m	8 A
	250 kbps	250 m		78 m	
	125 kbps	500 m		156 m	
Thin cable	500 kbps	100 m		39 m	3 A
	250 kbps	100 m		78 m	
	125 kbps	100 m		156 m	

Selecting between Thick and Thin Cable

The branch line length and total branch line length limitations are the same for both thin and thick cables. The cables differ in the following two capabilities.

1,2,3...

1. Maximum network length

With thin cable, the maximum network length is limited to 100 m in all cases. At 500 kbps, the maximum network length is the same for both thick and thin cables, so this limitation is not a consideration when the baud rate is 500 kbps.

Thick and thin cable can be used in the same network, but the max. network length declines as more thin cable is used. Refer to *Combining Thick and Thin Cables* on page 37 for the equations used to calculate the max. network length when thick and thin cable are used together.

2. Current capacity

In the trunk line, the cable current capacity (max. current allowed in the cable) is 3 A for thin cable and 8 A for thick cable. Consequently, thick cable can provide a significantly higher current when the communications power supply is being supplied through a Power Supply Tap. If thin cable is being used, the current in any one direction is limited to 3 A regardless of the capacity of the 24 V DC power supply that is connected.

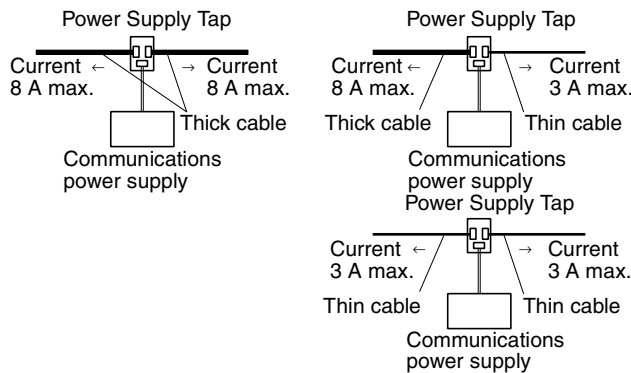

Note The communications power supply can also be supplied through a T-branch Tap or T-branch Connector, but the current capacity of a T-branch Tap is 5 A. The current capacity of the thin-cable T-branch Connectors is 3 A and the current capacity of the thick-cable T-branch Connector is 8 A. Consequently, the conditions for supplying power through a T-branch Tap or thin-cable T-branch Connector are as follows: There can be only one communications power supply in the network and the total current consumption (in both directions) is limited to 5 A for a T-branch Tap or 3 A for a thin-cable T-branch Connector.

Combining Thick and Thin Cables

Thick and thin cable can be combined in the line connecting most distant nodes, but the max. network length will be shorter than it would be with thick

cable alone. Use the following formulae to calculate the max. network length based on the lengths of thick and thin cable in the line.

Baud rate	Max. network length
500 kbps	$L_{THICK} + L_{THIN} \leq 100$ m
250 kbps	$L_{THICK} + 2.5 \times L_{THIN} \leq 250$ m
125 kbps	$L_{THICK} + 5 \times L_{THIN} \leq 500$ m

L_{THICK} : Length of thick cable in the maximum network length

L_{THIN} : Length of thin cable in the maximum network length

Example Calculation

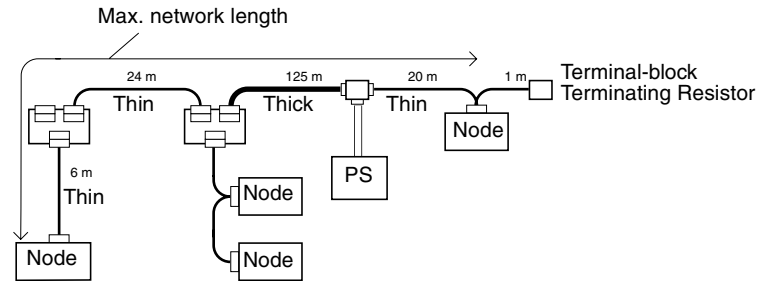

$$L_{THICK} + L_{THIN} = 175 \text{ m} \geq 100 \text{ m} \quad \text{500 kbps not allowed}$$

$$L_{THICK} + 2.5 \times L_{THIN} = 250 \text{ m} \leq 250 \text{ m} \quad \text{250 kbps OK}$$

$$L_{THICK} + 5 \times L_{THIN} = 375 \text{ m} \leq 500 \text{ m} \quad \text{125 kbps OK}$$

The results of the above formulae indicate that 250 kbps and 125 kbps can be used as the baud rates for this configuration example.

Even when the above conditions are met, however, the current flowing through the cables must not exceed the permissible current capacity. (Refer to SECTION 3 Communications Power Supply Methods.)

Applications Requiring Thin Cable

Thin cable must be used in applications where space is restricted and thick cable cannot be bent enough. In particular, use thin cable when wiring devices mounted to DIN Track and the area between the DIN Tracks is limited.

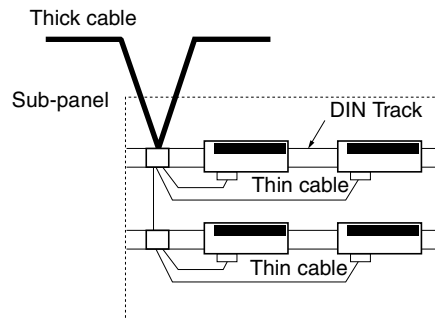

In conclusion, we recommend the following usage:

Application		Cable type
Trunk line		Thick cable
Branch lines	Unrestricted spaces such as outside panels	Thick cable
	Restricted spaces such as within panels	Thin cable

Proper Distance between Wiring Duct and Node

Allow about 10 cm between the wiring duct and nodes so that the nodes can be wired without straining the connectors. Communications errors may occur if there isn't enough slack in the cable and the connectors are pulled out.

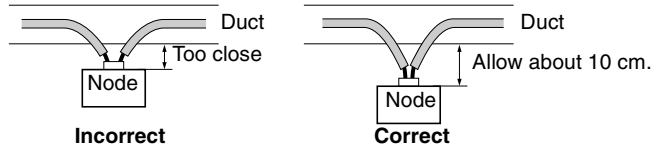

Note Do not strip too much insulation and shielding from the cable. Removing too much shielding will provide a path for noise to enter the network.

Considerations in Choosing Special Thin/Thick Cable or Special Flat Cable

Using Special Flat Cable makes it easy to extend a branch cable using one-touch connectors, but Special Flat Cable cannot be combined with a trunk line consisting of Special Thin/Thick Cable. There are differences between Special Thin/Thick Cable and Special Flat Cable in terms of maximum network length, branch line length, and current capacity. For detailed specifications, refer to 2-2-2 Trunk Lines and Branch Lines.

Trunk line	Branch line	Application
Flat cable	Thick cable	Connect to T-branch Tap.
	Thin cable	Connect using T-branch Connector (DCN4-TR4-1 + DCN4-BR4D).
	Flat cable	Connect using T-branch Connector (DCN4-TR4-1 + DCN4-BR4).
Thick cable	Flat cable	Connect to T-branch Tap.
Thin cable	Flat cable	Connect to T-branch Tap.

2-2-4 Determining the Location of the Master

It is not necessary to locate the Master at the end of the network. The Master can be located at any node position on the trunk line or a branch line. Configure the network as desired, since there is no restriction on the Master's location.

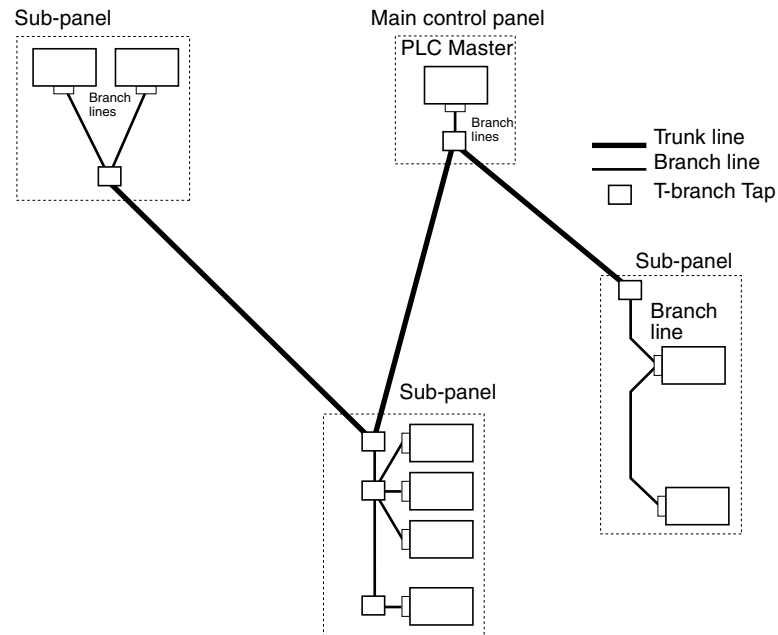

2-2-5 T-branch Tap Connections

The single-branch T-branch Taps (3 connectors) can be used to make a branch from the trunk line or a branch line. It isn't necessary to connect the paired connectors to the trunk line. Likewise, there is no restriction on the use of connectors in a three-branch T-branch Tap. The connectors can connect to the trunk line or branch lines.

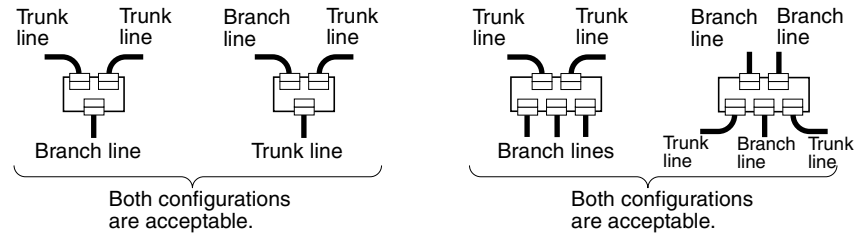

Although there is no restriction on the use of connectors in the T-branch Taps, as a rule we recommend using the paired connectors for the trunk line so that the trunk line is easy to identify.

2-2-6 Connecting Devices other than DeviceNet Products

Do not connect devices that are not DeviceNet products because incompatible devices can cause signal reflection or attenuation and interfere with normal network communications.

2-2-7 Connecting Terminators (Terminating Resistors)

What is a Terminating Resistor?

A Terminating Resistor (commonly known as a terminator) is a resistor connected to the end of the trunk line to absorb the signals sent through the network, dissipating the signals as heat and preventing them from bouncing back into the network. A Terminating Resistor is required at each end of the network (trunk line).

Note Terminating resistors are not built into DeviceNet devices.

Operation without Terminating Resistors

The DeviceNet network will not function properly without Terminating Resistors. Communications errors will occur, such as remote I/O communications errors and communications timeouts.

The signals in a DeviceNet network are comparable to surface waves on water. When a stone is dropped in a bucket of water, circular waves emanate from the stone and run into the sides of the bucket and the reflected waves interfere with the waves coming from the center. As a result, the waves from the center become distorted.

The same principle applies to the digital signals in a DeviceNet network. When the digital signals (waves) passing through the network reach the end of the network, the bounce back and interfere with the signals (waves) emanating from the DeviceNet Master (center) of the network.

The Terminating Resistors absorb the digital signals at the ends of the network so that they do not bounce back and distort the signals from the Master.

Operation with Too Many Terminating Resistors

If Terminating Resistors are attached at all T-branch Taps within the network, the digital communications signals will be absorbed midway through the network and the network will not function normally. Communications errors will occur, such as remote I/O communications errors and communications timeouts.

Checking the Installation of Terminating Resistors

If communications errors occur when setting up the system, it is possible to check whether or not the Terminating Resistors are connected properly. Turn OFF the network power supply and use a multimeter to test the resistance between any node's CAN H signal wire (white) and CAN L signal wire (blue).

- A normal resistance reading is 50 to 70 Ω .
- If the resistance is greater than 70 Ω , there may be a broken signal line in the network or one or both Terminating Resistors may be missing. A reading of about 100 Ω indicates that one Terminating Resistor is missing. A reading of about 300 Ω or higher indicates that both Terminating Resistors are missing.
- If the resistance is less than 50 Ω , there may be too many Terminating Resistors (3 or more) in the network.

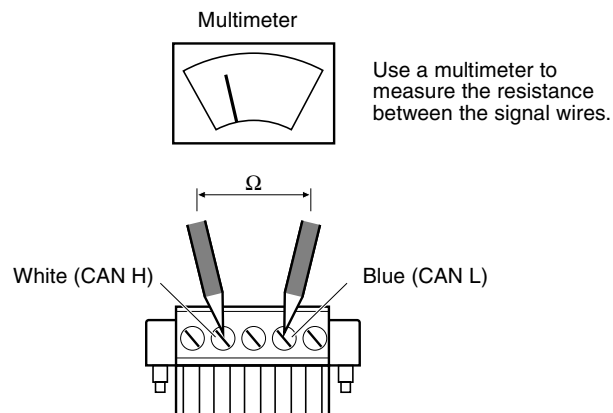

Note Do not test the resistance while the network is operating. Errors will occur in the communications data and could cause unexpected problems.

2-2-8 Using Crimp Terminals

We strongly recommend the use of crimp terminals (solderless pin terminals) on the wires that connect to the communications cable connectors. The following problems may occur if crimp terminals are not used.

1. A stray wire strand may contact the adjacent terminal and cause a short.
2. The cable may pull out of the connector.
3. The contact between the wire and connector may be poor.

Refer to *2-4 Wiring Methods* for information on recommended crimp terminals.

2-2-9 Sharing the Communications and Internal Circuit Power Supply

To avoid noise problems, it is generally recommended to provide separate communications and internal circuit power supplies, but the same power supply can be used for both purposes if necessary.

When a power supply is shared for the communications and internal circuit power supplies, wire the network as shown in configuration A. Do not use configuration B because it will generate more noise than configuration A.

Configuration A:

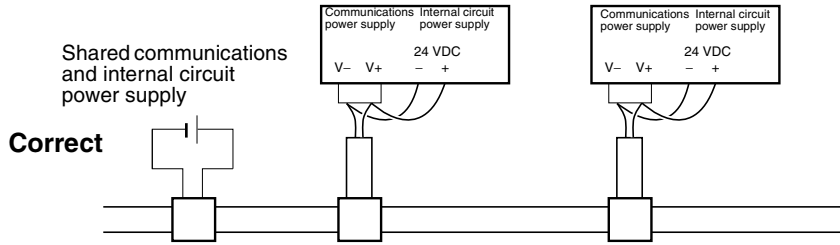

Configuration B:

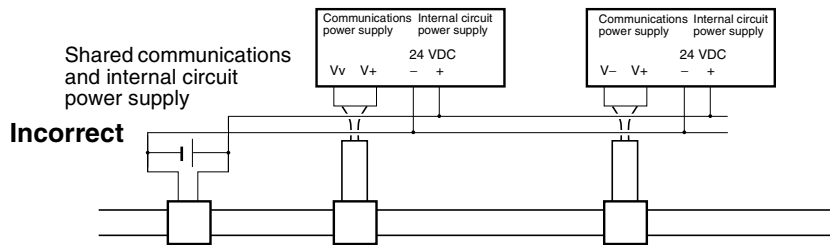

Note The low voltage limit for the internal circuit power supply is higher than the low voltage limit for the communications power supply. To meet the voltage specifications for the internal circuit power supply, be sure to follow the specifications listed in *SECTION 3 Communications Power Supply Methods*.

2-2-10 Grounding Methods

Proper Grounding Practices

Ground the DeviceNet shield wire to 100 Ω max. at one and only one point in the network. Grounding more than one point can cause ground loops and noise in the network.

Generally, the communications power supply's FG terminal is grounded to 100 Ω max. and connected to the V- terminal and the Power Supply Tap's shield (S) terminal, as shown in example A below. It is also acceptable to connect the communications power supply's FG terminal and the V- terminal and ground the network from the Power Supply Tap's shield (S) terminal, as shown in example B below.

In either case, ground the network as close to the center of the network as possible.

Example A

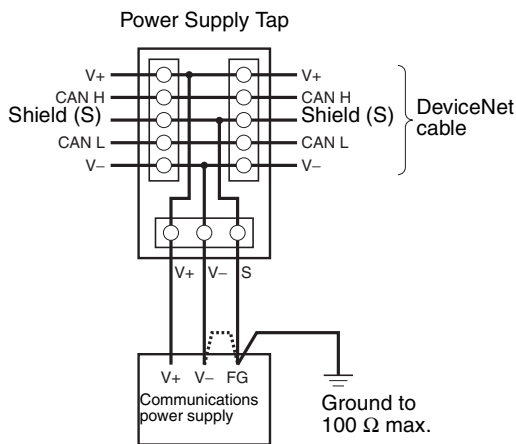

Example B

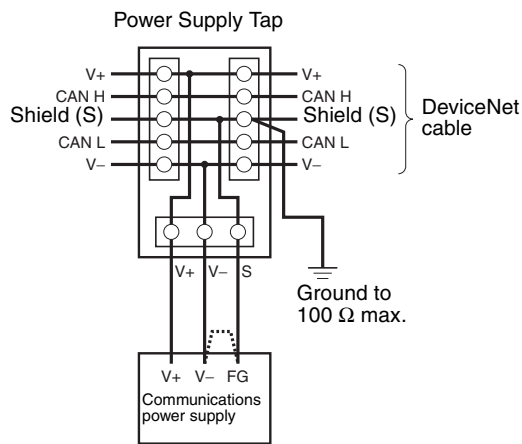

When there are two or more communications power supplies in the network, determine which power supply is closest to the center of the network. Connect

just that power supply's to the shield wire and ground it. Do not connect the shield wire at any other point.

- Note**
1. Do not ground the shield wire at more than one point in the network. Ground the network at one point and one point only.
 2. Always use a separate ground. Never use the same ground that is used for inverters or other drive system devices.
 3. If a good ground of 100 Ω or less is not available, do not connect the communication power supply's FG and V- terminals because the ground may introduce noise into the network.

Minimizing Effects of a Noisy Ground

When the ground is identified as a source of noise in the network, disconnect the DeviceNet shield wire to isolate it from the ground. If this step does not stop noise from entering the network, do not ground the communications power supply's FG terminal.

2-2-11 Allocating Node Numbers

Node numbers do not have to reflect the physical position of the nodes in the network. It is possible to allocate node numbers randomly. It is also acceptable to skip node numbers. While node numbers can be allocated randomly, we recommend following a pattern when allocating node numbers. For example, set the Master as node 63, the Slaves as nodes 1 through 62, and the Configurator as node 0.

2-3 Cables, Connectors, and Related Devices

2-3-1 Communications Cables

In a DeviceNet system, use DeviceNet cables that conforms to DeviceNet specifications. The cable characteristics affect DeviceNet communications, so cable that is not within DeviceNet specifications cannot be used. Always use the specified DeviceNet cables.

There are two kinds of Special Thin/Thick Cable: Thick Cable and Thin Cable. Thin Cable is used for the cables with attached shielded connectors.

Available Cables

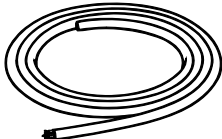
Cable	Appearance	Model	Specifications
Thick Cable		DCA2-5C10	Outer diameter: 11.6 mm Length: 100 m (See note.)
Thin Cable		DCA1-5C10	Outer diameter: 7 mm Length: 100 m (See note.)

Cable		Appearance	Model	Specifications	
Thin Cable	Cable with Shielded Connectors	<p>M12 size Plug (Male) Thin cable M12 size Socket (Female)</p>	DCA1-5CNC5W1	Length: 0.5 m	Thin cable with shielded, micro-size (M12) connectors on both ends
			DCA1-5CN01W1	Length: 1 m	
			DCA1-5CN02W1	Length: 2 m	
			DCA1-5CN03W1	Length: 3 m	
			DCA1-5CN05W1	Length: 5 m	
			DCA1-5CN10W1	Length: 10 m	
		<p>M12 size Socket (Female) Thin cable</p>	DCA1-5CNC5F1	Length: 0.5 m	Thin cable with shielded, micro-size (M12) connector on one end (Socket: Female)
			DCA1-5CN01F1	Length: 1 m	
			DCA1-5CN02F1	Length: 2 m	
			DCA1-5CN03F1	Length: 3 m	
			DCA1-5CN05F1	Length: 5 m	
			DCA1-5CN10F1	Length: 10 m	
		<p>M12 size Plug (Male) Thin cable</p>	DCA1-5CNC5H1	Length: 0.5 m	Thin cable with shielded, micro-size (M12) connector on one end (Plug: Male)
			DCA1-5CN01H1	Length: 1 m	
			DCA1-5CN02H1	Length: 2 m	
			DCA1-5CN03H1	Length: 3 m	
			DCA1-5CN05H1	Length: 5 m	
			DCA1-5CN10H1	Length: 10 m	
		<p>Mini-size Plug (Male) Thin cable M12 size Socket (Female)</p>	DCA1-5CN01W5	Length: 1 m	Thin cable with shielded connectors on both ends Mini-size plug (male) and micro-size (M12) socket: (female)
			DCA1-5CN02W5	Length: 2 m	
DCA1-5CN05W5	Length: 5 m				
DCA1-5CN10W5	Length: 10 m				
Thick Cable	Cable with Shielded Connectors	<p>Mini-size Plug (Male) Thick cable Mini-size Socket (Female)</p>	DCA2-5CN01W1	Length: 1 m	Thick cable with shielded, mini-size connectors on both ends
			DCA2-5CN02W1	Length: 2 m	
			DCA2-5CN05W1	Length: 5 m	
			DCA2-5CN10W1	Length: 10 m	
		<p>Mini-size Socket (Female) Thick cable</p>	DCA2-5CN01F1	Length: 1 m	Thick cable with shielded, mini-size connector on one end (Socket: Female)
			DCA2-5CN02F1	Length: 2 m	
			DCA2-5CN05F1	Length: 5 m	
			DCA2-5CN10F1	Length: 10 m	
		<p>Mini-size Plug (Male) Thick cable</p>	DCA2-5CN01H1	Length: 1 m	Thick cable with shielded, mini-size connector on one end (Plug: Male)
			DCA2-5CN02H1	Length: 2 m	
			DCA2-5CN05H1	Length: 5 m	
			DCA2-5CN10H1	Length: 10 m	
Flat Cable			DCA4-4F10	Dimensions: 10.16 × 2.54 mm Length: 100 m	

Note OMRON provides Flat Cable in 100-m lengths. Ask you OMRON representative if you need a different length.

Communications Cable and Communications Distance

Cable	Max. network length	Max. branch line length	Max. total branch line length
Thick cable	At 500 kbps: 100 m At 250 kbps: 250 m At 125 kbps: 500 m	6 m	At 500 kbps: 39 m At 250 kbps: 78 m At 125 kbps: 156 m
Thin cable (See note.)	100 m		
Flat cable	At 500 kbps: 75 m At 250 kbps: 150 m At 125 kbps: 265 m	6 m	At 500 kbps: 35 m At 250 kbps: 48 m At 125 kbps: 135 m

Note Thin cable includes the cables with shielded connectors attached.

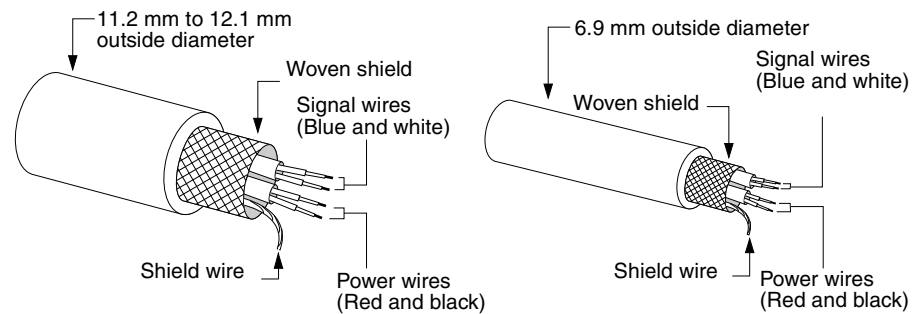

Wire type	Color	Function	Symbol
Signal wires	Blue	Communications signal, Low	CAN L
	White	Communications signal, High	CAN H
Power wires	Red	Communications power, positive	V+
	Black	Communications power, negative	V-
Shield wire	---	Shield	S

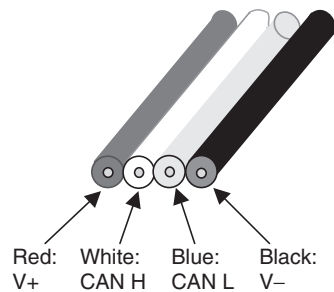

Conductor No.	Insulation color	Application	Nominal cross-section	Conductor resistance (Ω/km)	Allowable current (A)
1	Red	V+ (communications power supply positive side)	0.75 mm ² (AWG19)	25.0 max.	5 max.
2	White	CAN H (signal high)	0.5 mm ² (AWG21)	37.5 max.	---

Conductor No.	Insulation color	Application	Nominal cross-section	Conductor resistance (Ω/km)	Allowable current (A)
3	Blue	CAN L (signal low)	0.5 mm ² (AWG21)	37.5 max.	---
4	Black	V- (communications power supply negative side)	0.75mm ² (AWG19)	25.0 max.	5 max.

Connecting Communications Cables

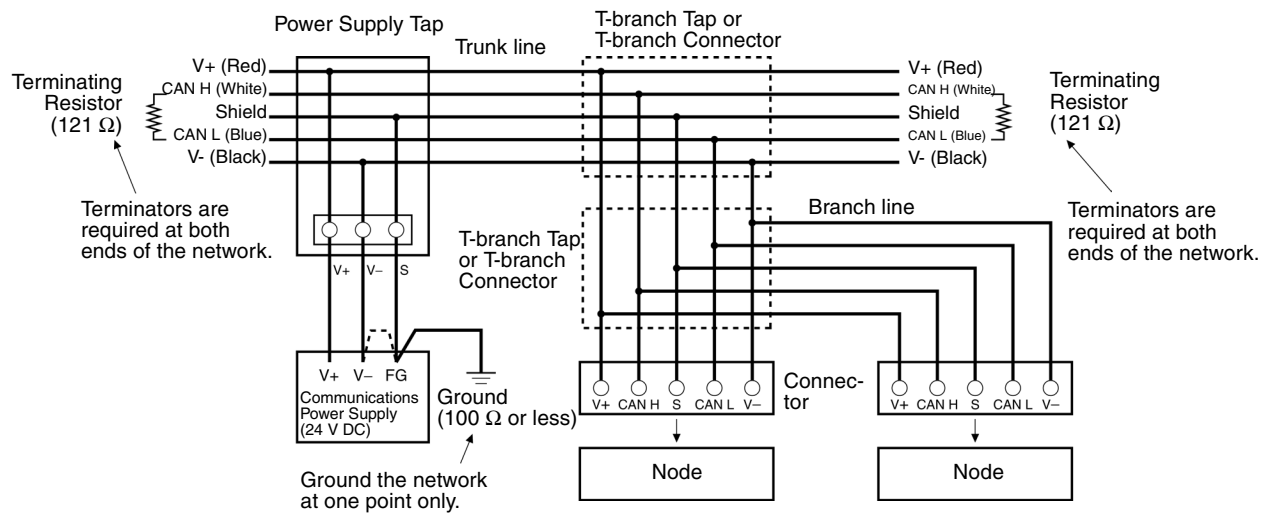

Note The ground may introduce noise into the network if a poor quality ground is used and the FG terminal is connected to the V- terminal. If a good ground of 100 Ω or less is not available, do not connect the communication power supply's FG and V- terminals.

Communications Cable Specifications

Special Thin/Thick Cable

Item	Thick Cable		Thin Cable	
	Signal wires	Power wires	Signal wires	Power wires
Model	DCA2-5C10		DCA1-5C10	
Conductor cross-sectional area	0.86 mm ²	2.17 mm ²	0.20 mm ²	0.38 mm ²
Conductor outer diameter	1.21 mm	1.92 mm	0.60 mm	0.80 mm
Color	Blue and white	Red and black	Blue and white	Red and black
Impedance	120 Ω ±10%	---	120 Ω ±10%	---
Propagation delay	1.36 ns/ft	---	1.36 ns/ft	---
Attenuation factor	500 kHz: 0.25 dB/100 ft 125 kHz: 0.13 dB/100 ft	---	500 kHz: 0.50 dB/100 ft 125 kHz: 0.29 dB/100 ft	---
Conductor resistance	6.9 Ω/1,000 ft 22.6 Ω/1,000 m	2.7 Ω/1,000 ft 8.9 Ω/1,000 m	28 Ω/1,000 ft 91.9 Ω/1,000 m	17.5 Ω/1,000 ft 57.4 Ω/1,000 m
Maximum current	---	8 A	---	3 A
Finished outer diameter	11.2 to 12.1 mm		6.9 mm	

Special Flat Cable

Item	Flat Cable	
	Signal wires	Power wires
Model	DCA4-4F10	
Conductor cross-sectional area	0.5 mm ²	0.75 mm ²
Conductor outer diameter	0.95 mm	1.2 mm
Color	Blue and white	Red and black
Impedance	120 Ω ±10%	---
Propagation delay	1.78 ns/ft	---
Attenuation factor	500 kHz: 0.42 dB/100 ft 125 kHz: 0.25 dB/100 ft	---
Conductor resistance	10.6 Ω/1,000 ft	6.9 Ω/1,000 ft
Maximum current	---	5 A
Finished outer diameter	2.54 × 10.16 mm	

Note There are a variety of DeviceNet cables available, such as cables for moving applications. For more details, refer to the homepage of the ODVA at <http://www.odva.org/>.

2-3-2 Connectors for Node Connections

Standard Connectors

The following table shows the standard connectors provided with Masters, Slaves, and T-branch Taps.

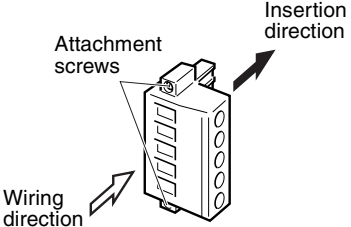
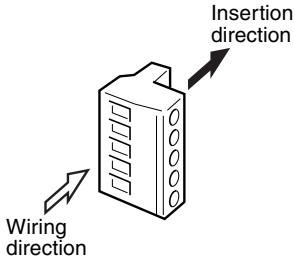
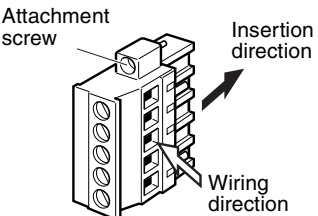
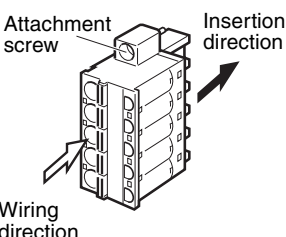
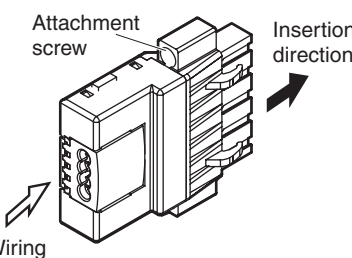
Name	Model	Specifications	Remarks
<p>Straight Connector with Attachment Screws</p> 	XW4B-05C1-H1-D	<p>Straight connector with attachment screws</p> <p>The insertion and wiring directions are the same.</p>	<p>This connector is provided with the DCN1-1C/2C/3C/4C T-branch Taps as well as Masters and Slaves other than those listed in the note.</p>
<p>COMBICON Plug</p> 	PHOENIX CONTACT MSTB 2.5/5-ST-5.08 AU	<p>Straight connector without connector attachment screws.</p> <p>The insertion and wiring directions are the same.</p>	<p>This connector is provided with the Masters and Slaves listed in the note.</p>
<p>Right-angle Connector with Attachment Screws</p> 	XW4B-05C1-VIR-D	<p>Right-angle connector with attachment screws</p> <p>The insertion and wiring directions are perpendicular.</p>	<p>This connector is provided with the DCN1-2R/4R T-branch Taps.</p>
<p>Straight Clamp Connector with Attachment Screws</p> 	XW4G-05C1-H1-D	<p>Straight connector with attachment screws</p> <p>The insertion and wiring directions are the same.</p>	<p>This connector is provided with the DCN1-1NC/3NC T-branch Taps and DRT2-series Masters and Slaves.</p>
<p>Flat Cable Connector</p> 	DCN4-SF4D	<p>Flat cable pressure-weld connector with attachment screws</p>	---

Note The following Units include a Straight Connector without Screws.

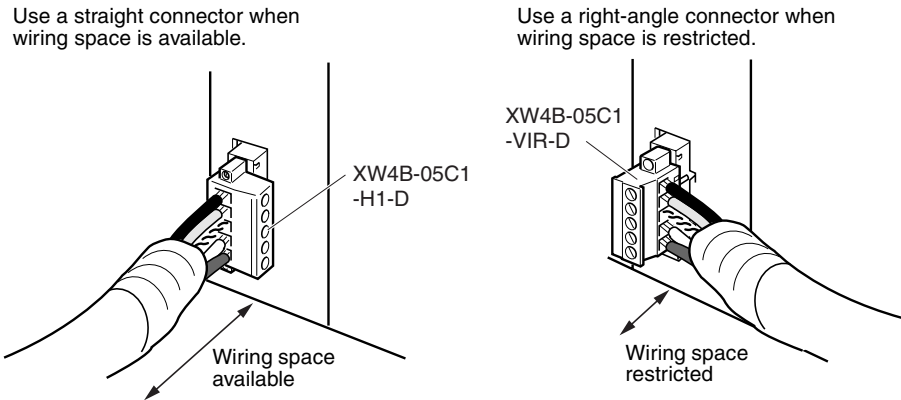

3G8B3-DRM21	DRT1-ID08(-1)	DRT1-ID16X(-1)
	DRT1-OD08(-1)	DRT1-OD16X(-1)
3G8E2-DRM21	DRT1-ID16(-1)	DRT1-HD16S
	DRT1-OD16(-1)	DRT1-ND16S
	DRT1-MD16	

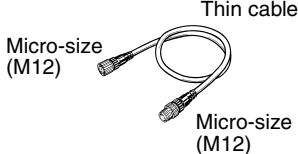
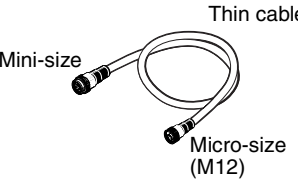
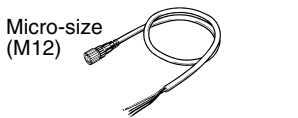
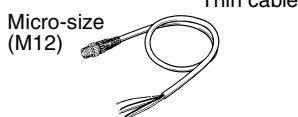

Shielded Connector Products

Use the following Cables and Connectors to connect to Environment-resistive Slaves and the shielded T-branch Connectors.

Name	Model	Specifications	Remarks
Thin cable with shielded, micro-size (M12) connectors on both ends 	DCA1-5CN□□W1	Used to connect a micro-size (M12) connector of a shielded T-branch Connector to another T-branch Connector or Environment-resistive Slave.	Cable lengths: 0.5 m 1 m 2 m 3 m 5 m 10 m
Thin cable with a shielded, micro-size (M12) female connector on one end and a mini-size male connector on the other 	DCA1-5CN□□W5	Used to connect a mini-size connector of a shielded T-branch Connector to a micro-size (M12) connector of another T-branch Connector	Cable lengths: 1 m 2 m 5 m 10 m
Thin cable with a shielded, micro-size (M12) female connector (socket) on one end 	DCA1-5CN□□F1	Used to connect a T-branch Tap to an Environment-resistive Slave.	Cable lengths: 0.5 m 1 m 2 m 3 m 5 m 10 m
Thin cable with a shielded, micro-size (M12) male connector (plug) on one end 	DCA1-5CN□□H1	Used to connect a micro-size (M12) connector of a shielded T-branch Connector to a device other than an Environment-resistive Slave, such as a Master, Slave, or T-branch Tap.	

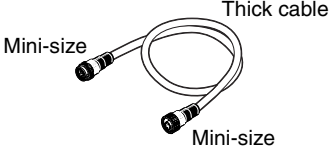
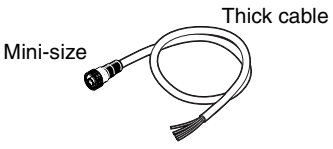
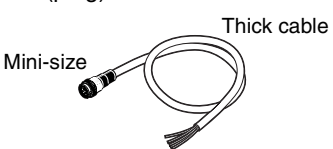
Name	Model	Specifications	Remarks
Shielded, micro-size (M12) female connector (socket) for custom cable assembly 	XS2C-D5S7	Connects to a micro-size (M12) connector of a shielded T-branch Connector or Environment-resistive Slave. Compatible with thin cable only.	---
Shielded, micro-size (M12) male connector (plug) for custom cable assembly 	XS2G-D5S7	Connects to a micro-size (M12) connector of a shielded T-branch Connector. Compatible with thin cable only.	---
Thick cable with shielded, mini-size connectors on both ends 	DCA2-5CN□□W1	Used to connect a mini-size connector of a shielded T-branch Connector to a mini-size connector of another shielded T-branch Connector or an Environment-resistive Slave. (Primarily used in the trunk line.)	Cable lengths: 1 m 2 m 5 m 10 m
Thick cable with a shielded, mini-size female connector (socket) on one end 	DCA2-5CN□□F1	Used to connect to a T-branch Connector or Environment-resistive Slave. (Primarily used in the trunk line.)	
Thick cable with a shielded, mini-size male connector (plug) on one end 	DCA2-5CN□□H1	Used to connect a mini-size connector of a shielded T-branch Connector to a device other than an Environment-resistive Slave, such as a Master, Slave, or T-branch Tap. (Primarily used in the trunk line.)	

Multi-drop Connectors

The following table shows connectors that can be used for multi-drop connections. These connectors are not supplied with OMRON products, but must be ordered separately. Since these connectors cannot be used with all DeviceNet devices, check that the connector is compatible before ordering.

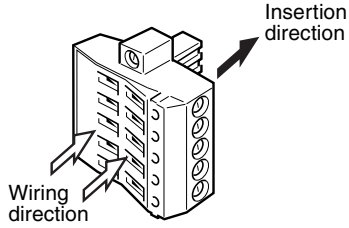
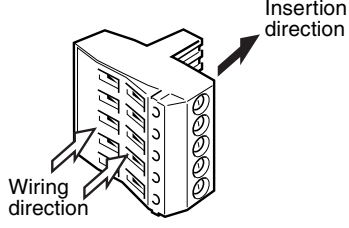
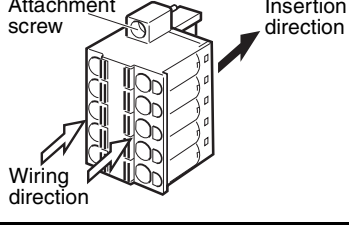
Name	Model	Specifications	Remarks
Straight multi-drop connector with attachment screws 	XW4B-05C4-TF-D	Straight multi-drop connector with attachment screws The insertion and wiring directions are the same.	These multi-drop connectors cannot be used with all Masters and Slaves. See the note following this table for a list of the compatible Units.
Straight multi-drop connector without attachment screws 	XW4B-05C4-T-D	Straight multi-drop connector without attachment screws The insertion and wiring directions are the same.	
Straight multi-drop clamp connector with attachment screws 	XW4G-05C4-TF-D	Straight multi-drop connector with attachment screws The insertion and wiring directions are the same.	

Note The multi-drop connectors can be used with the following Units

CS1W-DRM21	DRT1-ID16T(-1)	DRT2-ID08(-1)	DRT2-ID16SL(-1)
CJ1W-DRM21	DRT1-MD16T(-1)	DRT2-OD08(-1)	DRT2-OD16SL(-1)
CPM2C-S100C-DRT	DRT1-OD16T(-1)	DRT2-ID16(-1)	DRT2-ID16SLH(-1)
CPM2C-S110C-DRT	DRT1-ID16TA(-1)	DRT2-OD16(-1)	DRT2-OD16SLH(-1)
CPM1A-DRT21	DRT1-MD16TA(-1)	DRT2-MD16(-1)	DRT2-ID32SL(-1)
	DRT1-OD16TA(-1)	DRT2-AD04	DRT2-OD32SL(-1)
	DRT1-ID32ML(-1)	DRT2-DA02	DRT2-MD32SL(-1)
	DRT1-MD32ML(-1)	DRT2-ROS16	DRT2-ID32SLH(-1)
	DRT1-OD32ML(-1)	DRT2-ID16TA(-1)	DRT2-OD32SLH(-1)
	DRT1-232C2	DRT2-OD16TA(-1)	DRT2-MD32SLH(-1)
	DRT1-COM	DRT2-MD16TA(-1)	
		DRT2-ID16S(-1)	
		DRT2-ID16ML(-1)	
		DRT2-OD16ML(-1)	
		DRT2-ID16MLX(-1)	
		DRT2-OD16MLX(-1)	
		DRT2-ID32ML(-1)	
		DRT2-OD32ML(-1)	
		DRT2-MD32ML(-1)	

Multi-drop Wiring

Always use a multi-drop connector when making a multi-drop connection with thick cable. When thin cable is being used, the multi-drop connection can be made with either a multi-drop connector or a standard rectangular connector. Refer to *Multi-drop Wiring Methods* on page 65 for details on proper multi-drop wiring methods.

2-3-3 Screwdrivers for Connector Screws

Special Screwdrivers

We recommend using one of the following special screwdrivers when connecting communications cables to the standard connectors.

Name	Model	Manufacturer
Screwdriver for DeviceNet connectors	XW4Z-00C	OMRON
	SZF-1	PHOENIX CONTACT

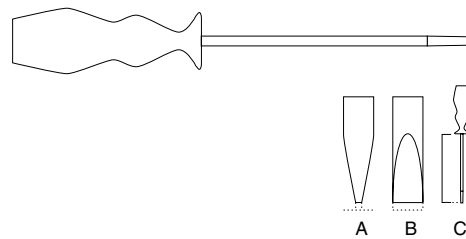

Units: mm

A	B	C
0.6	3.5	100

Pliers

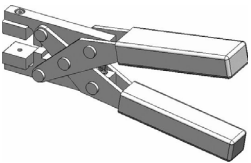





Name	Appearance	Model	Application
Pliers		DWT-A01	Pliers for pressure-welding a DCN4-TR4-1 Flat Connector Socket or a DCN4-BR4 Flat Connector Plug.

2-3-4 T-branch Taps

Use a T-branch Tap when a T-branch is required in the Network. There are two kinds of T-branch Taps, one that makes a single branch and another that makes three branches. There are variations of the single-branch and three-branch Taps that provide different wiring directions and connector insertion directions.

- Note**
1. A T-branch Tap cannot be used to create a T-branch in a Network that has cables with shielded connectors. In this case, a T-branch Connector must be used. Refer to *2-3-5 Shielded T-branch Connectors* for details.
 2. Because the T-branch Tap has a Terminating Resistor socket, a Terminating Resistor can be connected to the trunk line by installing one of the resistors provided.
 3. When the Network is powered by a single power supply and the total current consumption is 5 A or less, a T-branch Tap can be used instead of a Power Supply Tap to connect the communications power supply.
 4. The T-branch Taps are identical in models DCN1-2C, DCN1-2R, DCN1-4C, and DCN1-4R; just the connectors included with the Tap are different.

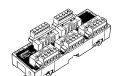
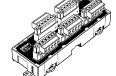
T-branch Taps

Branches	Model	Number of connectors	Connectors provided	Wiring direction	Insertion direction	Set screw access	Terminating Resistance
Single-branch	DCN1-1NC 	3 connectors (for 1 branch)	XW4G-05C1-H1-D Straight clamp connector with attachment screws (3 attached)	From top	From top	From top	Can be installed (provided with Unit)
	DCN1-1C 		XW4B-05C1-H1-D Straight connector with attachment screws (3 attached)	From side	From side	From top	
	DCN1-2C 			From top	From top	From side	
	DCN1-2R 		XW4B-05C1-VIR-D Right-angle connector with attachment screws (3 attached)	From side	From top	From top	
Three-branch	DCN1-3NC 	5 connectors (up to 3 branches)	XW4G-05C1-H1-D Straight clamp connector with attachment screws (5 attached)	From top	From top	From top	Can be installed (provided with Unit)
	DCN1-3C 		XW4B-05C1-H1-D Straight connector with attachment screws (5 attached)	From side	From side	From top	
	DCN1-4C 			From top	From top	From side	
	DCN1-4R 		XW4B-05C1-VIR-D Right-angle connector with attachment screws (5 attached)	From side	From top	From top	

Cable Wiring Direction and Connector Insertion Direction

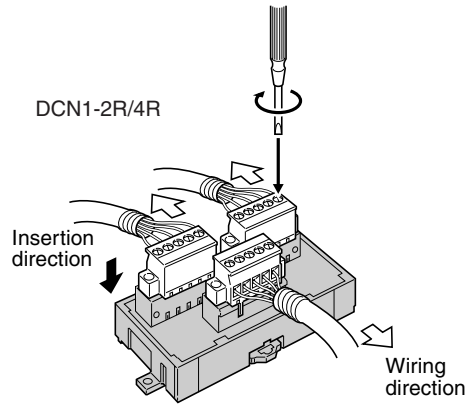
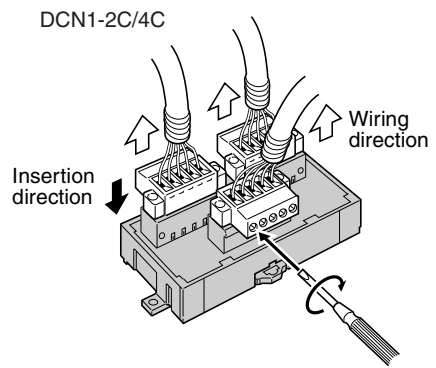
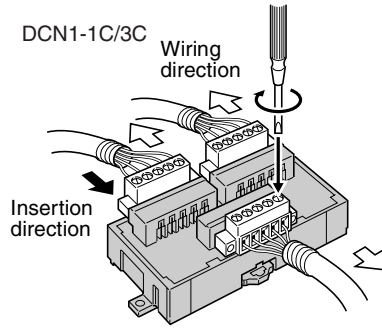

Components and their Functions

DCN1-1NC T-branch Tap Components

Communications Connectors
 Connect the network communications cable to the provided XW4G-05C1-H1-D Connectors.

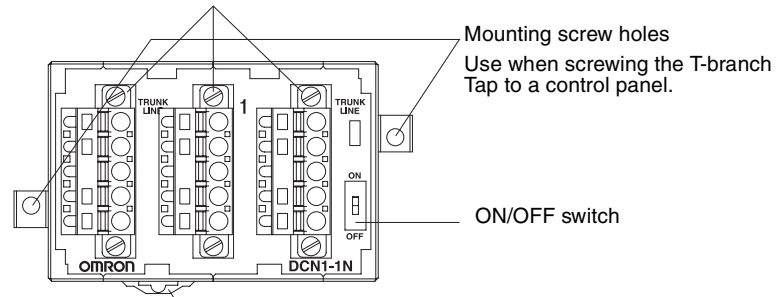

Mounting screw holes
 Use when screwing the T-branch Tap to a control panel.

ON/OFF switch

DIN Track mounting hook
 Use when mounting the Tap to a DIN Track.
 A trunk line is usually connected here.

DCN1-1C T-branch Tap Components

Communications Connectors
 Connect the network communications cable to the provided XW4B-05C1-H1-D Straight Connectors.

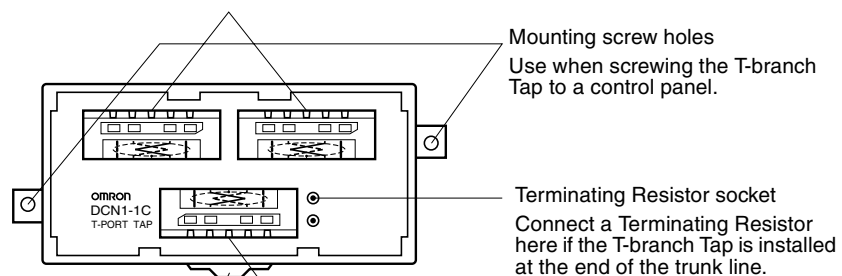

Mounting screw holes
 Use when screwing the T-branch Tap to a control panel.

Terminating Resistor socket
 Connect a Terminating Resistor here if the T-branch Tap is installed at the end of the trunk line.

Communications Connector
 Connect the network communications cable to the provided XW4B-05C1-H1-D Straight Connector.

DIN Track mounting hook
 Use when mounting the Tap to a DIN Track.
 A trunk line is usually connected here.

DCN1-2C and DCN1-2R T-branch Tap Components

Communications Connectors

Connect the network communications cable. The following connectors are provided.

DCN1-2C: XW4B-05C1-H1-D Straight Connector with attachment screws

DCN1-2R: XW4B-05C1-VIR-D Right-angle Connector with attachment screws

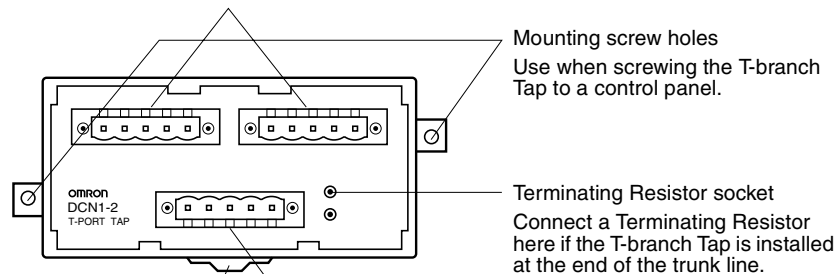

Communications Connector

Connect the network communications cable. The following connectors are provided.

DCN1-2C: XW4B-05C1-H1-D Straight Connector with attachment screws

DCN1-2R: XW4B-05C1-VIR-D Right-angle Connector with attachment screws

DIN Track mounting hook

Use when mounting the Tap to a DIN Track.

A trunk line is usually connected here.

DCN1-3NC T-branch Tap Components

Communications Connectors

Connect the network communications cable. The following connectors are provided.

XW4G-05C1-H1-D Straight Clamp Connector with attachment screws

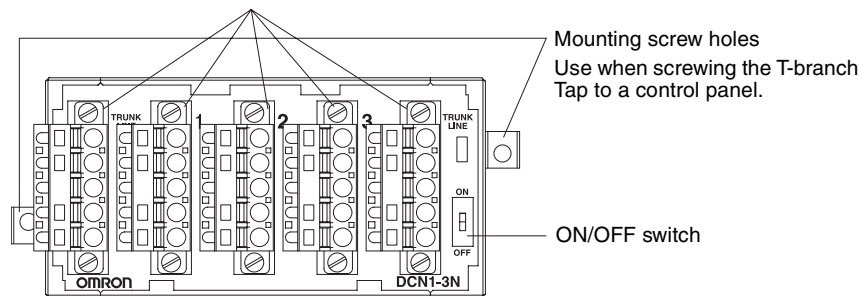

DIN Track mounting hooks

Use when mounting the Tap to a DIN Track.

A trunk line is usually connected here.

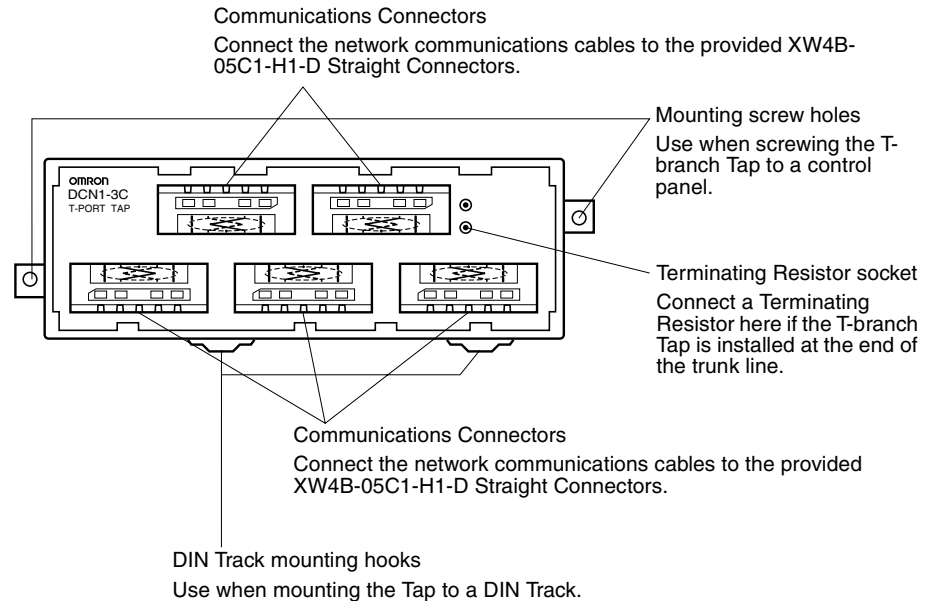
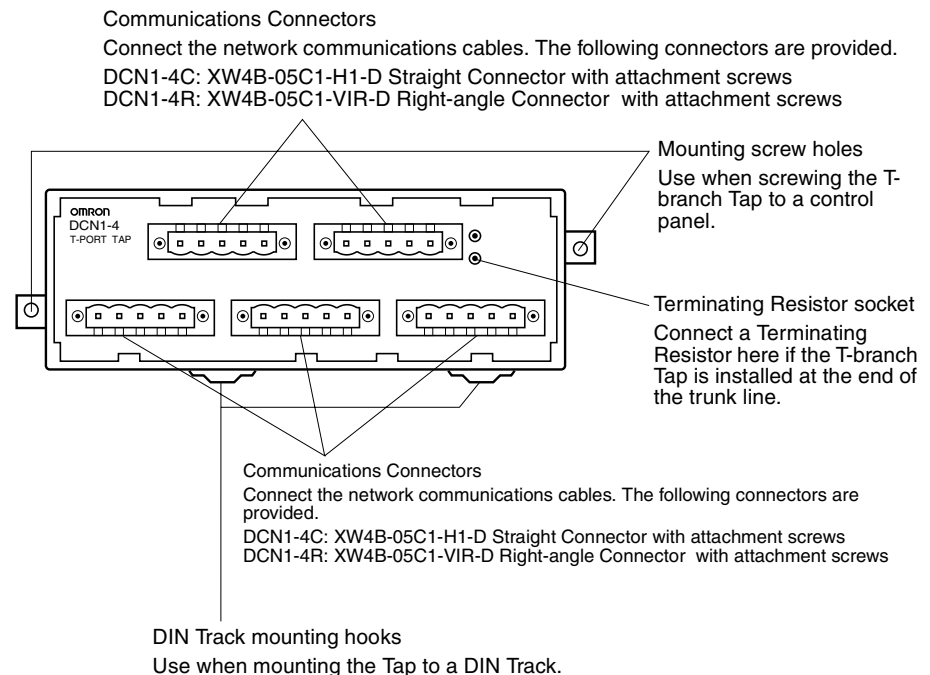
DCN1-3C T-branch Tap Components**DCN1-2C and DCN1-2R T-branch Tap Components****2-3-5 Shielded T-branch Connectors**

Use a T-branch Connector when a T-branch is required in a Network that has communications cables with shielded connectors.

- Note**
1. If the T-branch Connector is at the end of the trunk line, the trunk line can be terminated by connecting a shielded connector with Terminating Resistance. (Male plug and female socket terminators are available.)
 2. When the Network is powered by a single communications power supply and the current consumption is within the T-branch Connector's specifications, the communications power supply can be connected to a T-branch

Connector (using a shielded cable with a connector on one end) instead of a Power Supply Tap.

Model	Remarks
DCN2-1	Shielded T-branch Connector (1 branch) with 3 micro-size (M12) connectors Maximum current: 3 A
DCN3-11	Shielded T-branch Connector (1 branch) with 3 mini-size connectors Maximum current: 8 A
DCN3-12	Shielded T-branch Connector (1 branch) with 2 mini-size connectors and 1 micro-size (M12) connector Maximum current: 8 A (3 A max. through the micro-size connector)

DCN2-1

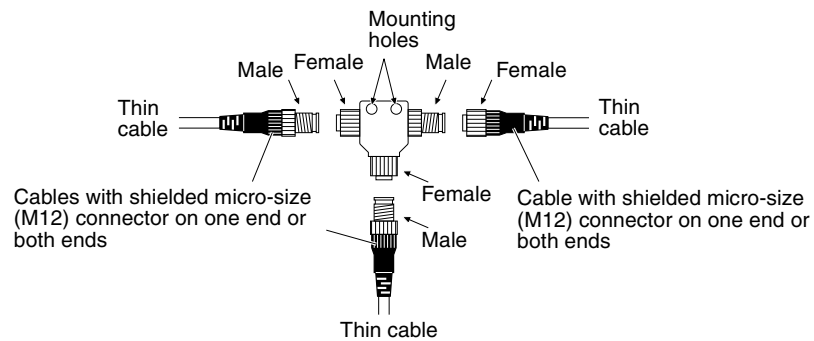

DCN3-11

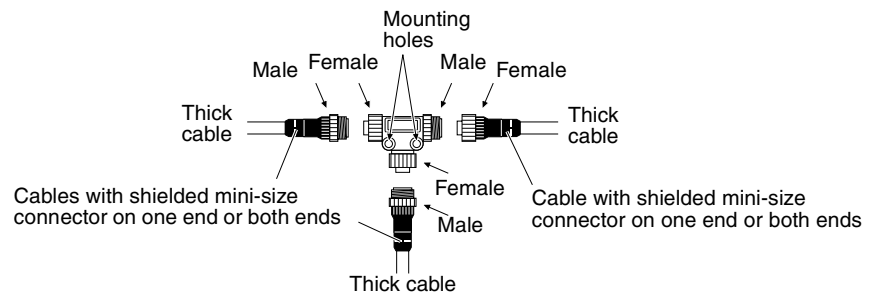

DCN3-12

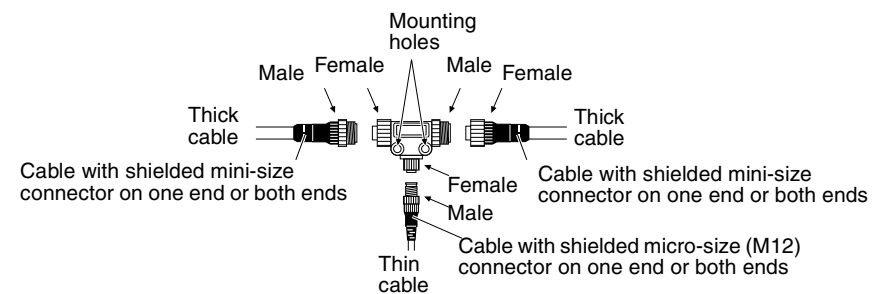

Internal Circuitry

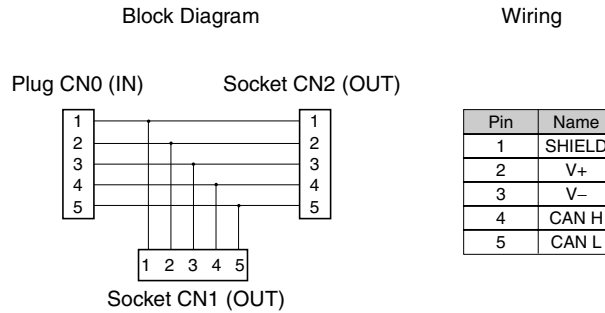

2-3-6 Flat Cable T-branch Connectors

Types of T-branch Connectors

Appearance	Model	Application
	DCN4-TR4-1	Used together with the DCN4-BR4 or the DCN4-BR4D to extend trunk or branch lines or to T-branch the trunk line. Can also be used to connect a DCN4-TM4 Terminating Resistor.
	DCN4-BR4	Used together with the DCN4-TR4-1 to extend or branch flat cable.
	DCN4-BR4D	Used together with the DCN4-TR4-1 to branch to thin cable.

2-3-7 Power Supply Tap

In the DeviceNet system, a 24-V DC communications power supply must be supplied to the Network. The communications power supply can be supplied to the cable by connecting it to a Power Supply Tap. Use a regular node connector to connect communications cable to the Power Supply Tap, the same way that communications cables are connected to a T-branch Tap.

- Note**
1. If there is just one power supply to the Network and the total current consumption is less than 5 A, the communications power supply can be connected through a regular T-branch Tap instead of a Power Supply Tap. A Power Supply Tap must be used if there is more than one power supply connected to the Network or the total current consumption exceeds 5 A.
 2. When the Power Supply Tap is connected to thin cable, the current capacity is limited to 3 A through any one of the thin cables. If two thin cables are connected, 3 A can be supplied to each cable for a total of 6 A.

(If two thick cables are connected, 8 A can be supplied to each cable for a total of 16 A.)

Model	Remarks
DCN1-1P	Includes two XW4B-05C1-H1-D Straight Connectors with attachment screws, a terminator (attach if needed), fuses, and a ground terminal.

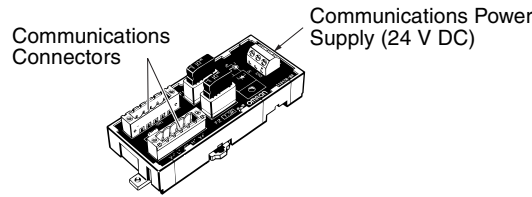

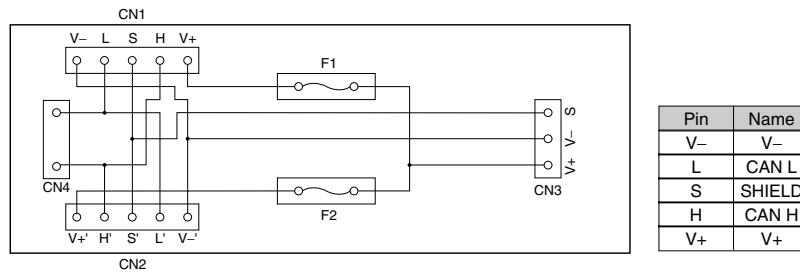

Internal Circuitry



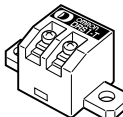

2-3-8 Terminating Resistors

In a DeviceNet Network, one Terminating Resistor must be connected to each end of the trunk line. If a Unit is at the end of the trunk line, connect one of the Terminating Resistors listed in the following table because the Units do not have built-in terminators.

There are several ways to connect a Terminating Resistor. A special Terminal-block Terminating Resistor can be connected, a resistor can be installed in the Terminating Resistor socket of a T-branch Tap or Power Supply Tap, or a shielded connector with terminating resistance can be connected to a T-branch Connector. A Terminating Resistor is provided with T-branch Taps and Power Supply Taps. If a resistor is to be installed on a T-branch Tap or Power Supply Tap, always use the provided Terminating Resistor.

Model	Remarks
(No model number) 	Terminating Resistor provided with T-branch Taps and Power Supply Taps (121 Ω ±1%, 1/4 W)
DRS1-T 	Terminal-block Terminating Resistor (121 Ω ±1%, 1/4 W)
DRS2-1 	Shielded Micro-size (M12) Connector with Terminating Resistance (male plug)
DRS2-2 	Shielded Micro-size (M12) Connector with Terminating Resistance (female socket)

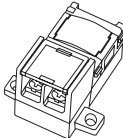
Model	Remarks
DRS3-1 	Shielded Mini-size Connector with Terminating Resistance (male plug)
DCN4-TM4 	Used to connect the DCN4-TR4-1.
DCN4-TP4D 	Flat Cable Power Supply Terminal Block with Terminating Resistance When flat cable is used, communications power can be supplied from the terminals on this terminal block.

2-3-9 Communications Power Supply

In a DeviceNet system, a 24-V DC communications power supply must be supplied to the Network. The communications power supply must meet the specifications listed in the following table and the AC inputs and DC outputs must be isolated.

The OMRON S82J-series and S82K-series Power Supply Units are recommended. Select a Power Supply Unit with a current capacity that can comfortably handle the total power consumption of all connected nodes and allow for future expansion if necessary.

Communications Power Supply Specifications

The communications power supply must meet the following specifications.

Item	Specifications
Output voltage	24 V DC $\pm 1\%$
Output current	16 A max.
Input fluctuation	0.3% max.
Load fluctuation	0.3% max.
Temperature effect	0.03%/°C max.
Input voltage	100 to 1,200 V
Input frequency	47 to 450 Hz
Output ripple	250 mVp-p
Output capacitance	7,000 μ F max.
Ambient temperature	Operating: 0 to 60°C Storage: -40 to 85°C
Max. instantaneous output current	65 A max. (peak)
Overvoltage protection	Must be provided.
Overcurrent protection	Must be provided. (max. current: 125%)
Startup time	Must reach 5% of final output voltage within 250 ms.
Startup overshoot	0.2% max.
Insulation	Between output and AC power and between output and chassis ground
Standards	Required: UL Recommended: FCC Class B, CSA, TÜV, and VDE

Item	Specifications
Ambient humidity	30% to 90% (with no condensation)
Surge current capacity	10% max.

Note The current capacity of thick cable is 8 A, so up to 16 A can be supplied to the network by supplying communications power in two directions from the power supply through thick cables.

The current capacity of thin cable is limited to 3 A. Up to 6 A can be supplied to the network when communications power is supplied in two directions from the power supply through thin cables.

If a thin cable is connected in one direction and a thick cable is connected in the other, the maximum current is $3\text{ A} + 8\text{ A} = 11\text{ A}$ total.

2-4 Wiring Methods

2-4-1 Wiring and Installing Standard Connectors

Attaching Communications Cables

Use the following procedure to prepare and connect the communications cables to the connectors.

- 1,2,3...
- Strip about 30 mm of the cable sheathing, being careful not to damage the woven shield just below the sheathing. Do not remove more than about 30 mm; removing too much of the covering can result in short circuits or allow noise into the Network.

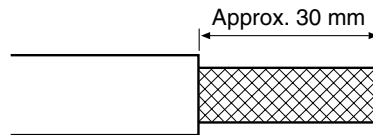

- Carefully peel back the woven shield. There is a bare shield wire under the woven shield as well as the signal lines and power lines. (The shield wire will be loose on the outside of the other lines, but it is stiffer than the woven shield and easy to identify by touch.)

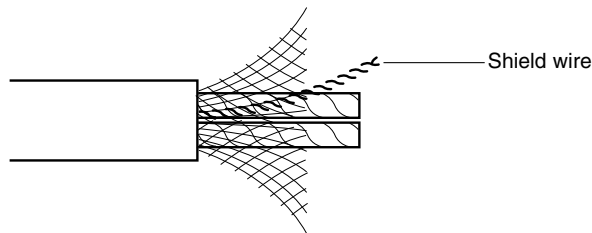

- Cut away the exposed woven shield, remove the aluminum tape from the signal and power lines, and strip the sheath from the signal and power lines to the proper length for the crimp terminal connectors. Twist together the stranded wires of each signal and power lines.

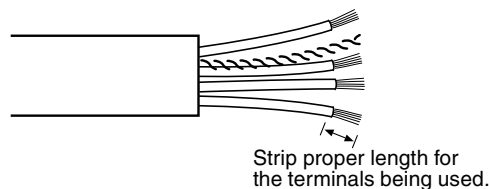

- Attach the crimp terminals (solderless pin terminals) to the lines and use the proper Crimping Tool to crimp the terminal securely.

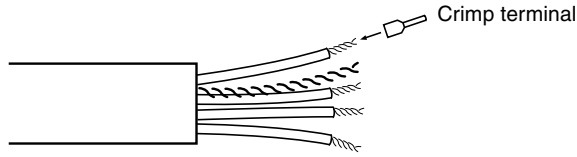

Note We recommend using the following crimp terminals and crimping tools.

- PHOENIX CONTACT, AI-series Crimp Terminals

Cable type		XW4B-05C1-H1-D XW4B-05C1-V1R-D MSTB2.5/5-ST-5.08AU	XW4B-05C4-TF-D XW4B-05C4-T-D	XW4G-05C1-H1-D XW4G-05C4-TF-D	Crimping Tool
Using thin cables	Signal lines	A10.25-6YE	A10.25-8YE	A10.25-8YE	CRIMPFOX ZA3
	Power lines	A10.5-6WH	A10.5-10WH	A10.5-10WH	
Using thick cables	Signal lines	A1-6	A1-10	A1-10	
	Power lines	AI 2.5-8BU	AI 2.5-10BU	AI 2.5-10BU	

- Cover the end of the cable with electrical tape or heat-shrink tubing as shown in the following diagram.

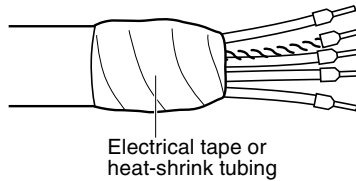

- Check that the connector is oriented correctly and the wire set screws are loose enough to insert the wires. Insert the power lines, signal lines, and shield wire in the correct holes in the following order (top to bottom): black, blue, shield, white, and red.

- Straight Connectors

With straight connectors, the wiring direction and connector insertion direction are the same. Use the straight connectors if there is sufficient wiring space.

Straight Connector with Attachment Screws

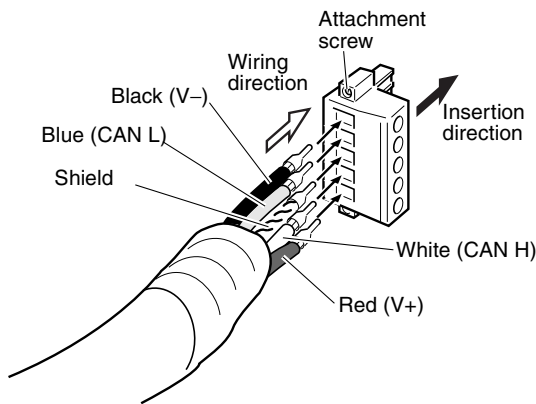

Straight Connector without Attachment Screws

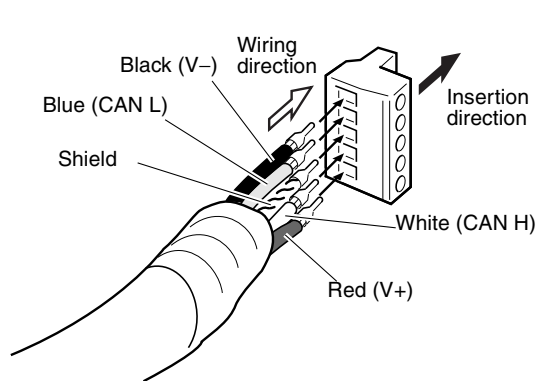

- Right-angle Connectors

With right-angle connectors, the wiring direction and connector inser-

tion direction are perpendicular. Use right-angle connectors if there is insufficient wiring space in front of the DeviceNet connectors and the connectors must be wired from the side.

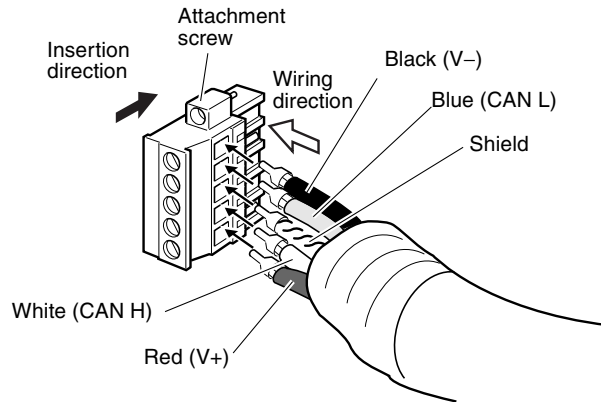

Connectors without set screws do not require lines to be secured with screws as with previous connectors. Push up the orange lever and then insert each line into the back of each hole. Release the orange lever after inserting the lines, and gently pull each line to check that it is securely connected to the connector.

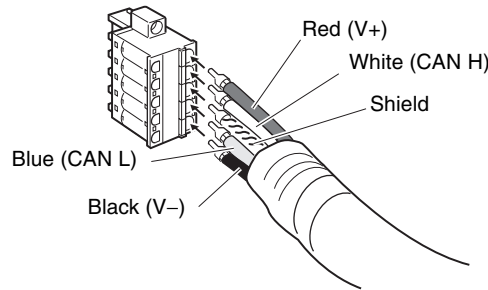

Note (a) Be sure that the wire set screws are sufficiently loosened before attempting to insert the lines. If these screws are not loose, the wires will go into the space in the back of the connector and cannot be locked with the set screws.

(b) There are colored stickers provided on the Master Unit and Slave Units that match the colors of the lines to be inserted. Be sure that the colors match when wiring the connectors.

(c) The following table shows the cable colors:

Color	Signal	Symbol
Black	Communications power supply, negative	V-
Blue	Signal line, Low	CAN L
---	Shield	S
White	Signal line, High	CAN H
Red	Communications power supply, positive	V+

7. Tighten the connector's set screws on the wires using a slotted screwdriver that doesn't taper at the tip, which will prevent the screwdriver from binding in the connector. Tighten the screws to a torque of between 0.25 and 0.3 N·m

When using thick cable, provide some slack in the cable so that the connectors do not pull out because of tension on the cable.

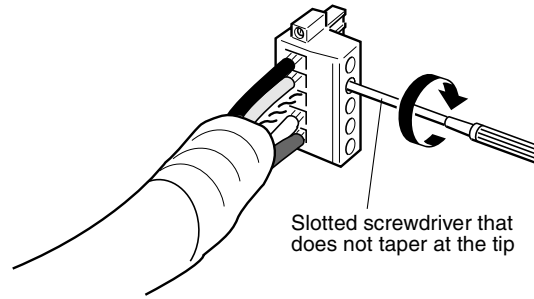

Note The OMRON XW4Z-00C and PHOENIX CONTACT SZF-1 screwdrivers are suitable for tightening the DeviceNet connector's set screws. Refer to *2-3 Cables, Connectors, and Related Devices* for contact information to order the PHOENIX CONTACT screwdriver. The following diagram shows the dimensions of the XW4Z-00C screwdriver.

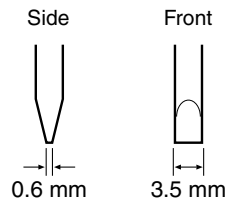

Multi-drop Wiring Methods

Multi-drop Connection with a Standard Connector (Thin Cables Only)

When thin cable is being used, a multi-drop connection can be made by inserting each pair of wires into a single same pin terminal and crimping them together.

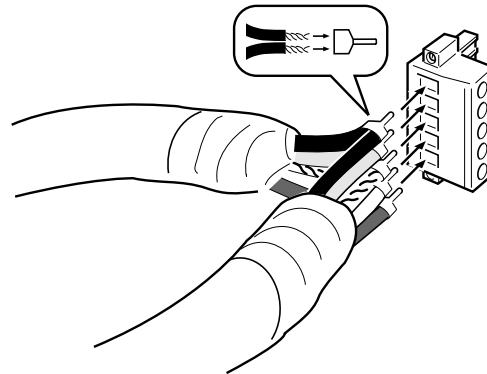

Note We recommend using the following PHOENIX CONTACT terminal for this type of multi-drop connection.

- PHOENIX CONTACT AI-TWIN Series

Model	Crimping Tool
AI TWIN2 × 0.5-8WH (for thin cable)	CRIMPFOX UD6

Multi-drop Connection with a Multi-drop Connector

The following OMRON Multi-drop Connectors (sold separately) can be used to make a multi-drop connection with either thin or thick cable.

- XW4B-05C4-T-D Straight Multi-drop Connector without Attachment Screws

- XW4B-05C4-TF-D Straight Multi-drop Connector with Attachment Screws
- XW4G-05C4-TF-D Straight Multi-drop Clamp Connector with Attachment Screws

In some cases, the Multi-drop Connector cannot be used because there is not enough space and other Units or connectors get in the way. Refer to *Multi-drop Connectors* on page 51 for a list of compatible Units.

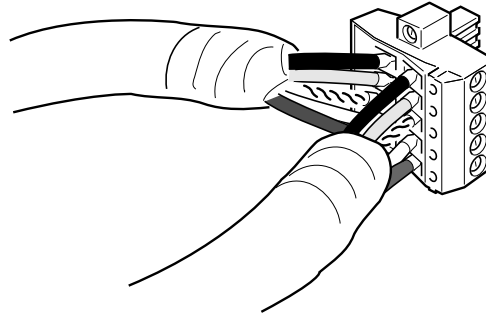

- Note**
1. Before connecting the communications cables, turn OFF the power supplies to the PLC and all Slaves, as well as the communications power supplies.
 2. Use crimp terminals for wiring. Connecting bare twisted wires can cause the cables to come OFF, break, or short circuit and result in incorrect operation and possibly damage to the Units.
 3. Use the proper crimping tool and crimping methods when attaching crimp terminals. Consult the manufacturer of the tools and terminals you are using. Inappropriate tools or methods can result in broken wires.
 4. Be extremely careful to wire all signal lines, power lines, and shielding wire correctly.
 5. Tighten all set screws firmly. Tighten signal lines, power lines, and shielding wire to a torque of 0.5 to 0.6 N-m. Tighten connector screws to a torque of 0.4 to 0.5 N-m.
 6. Wire the signal lines, power lines, and shielding wire so that they do not become disconnected during communications.
 7. Do not pull on the communications cables. They may become disconnected or wires may break.
 8. Allow a sufficient bending radius in cable turns so that communications cables are not bent too sharply. The Cables may become disconnected or wires may break if the cables are bent too far.
 9. Never place objects on top of the communications cables. They may break.
 10. Double-check all wiring before turning ON the power supply.

2-4-2 Attaching Flat Cable Connectors

Flat Connector Plug Component Names

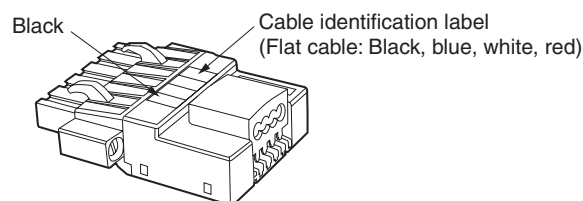

- 1,2,3...**
1. Cut the cable.
Cut the cable perpendicular to the length.
To prevent short-circuits, cut the cable with a sharp tool, such as wire cutters, and make sure that no whiskers are left on the wires.

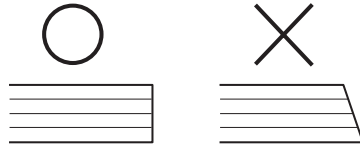

2. Attach the cable.
Align the indications on the cable identification label with the cable colors and insert the cable. The cover is translucent, so it is possible to confirm that the cable has been inserted all the way in.

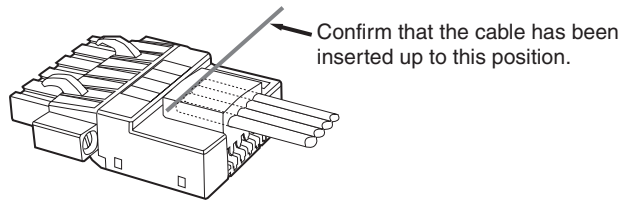

3. Pressure-weld the connector.
Use the DWT-A01 Pliers to pressure-weld the connectors.
1) As shown in the following diagram, align the center of the connector cover (see arrows) with the center of the pressure-welding block on the Pliers.

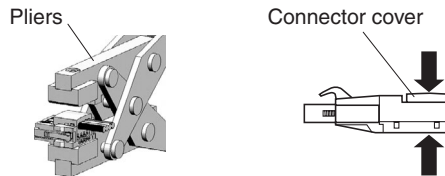

- 2) Squeeze firmly on the Pliers until the lock on the connector clicks into place.

- Note**
1. Do not pressure-weld the connector cover at the edges.
 2. Do not pressure-weld the connector cover at the back of the pressure-welding block.
 3. Set the connector in the correct orientation.

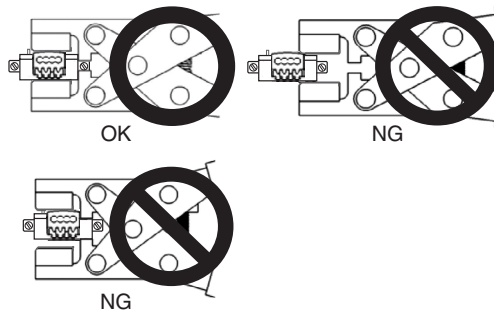

- After attaching the cable, confirm that it is properly pressure-welded as shown below.

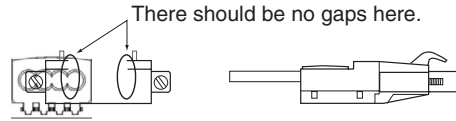

2-4-3 Attaching Shielded Connectors

Use the following procedure to attach shielded connectors to the communications cables. This section explains the basic attachment procedure. For more details on connector assembly methods, refer to XS2 in the *Sensor I/O Connectors Catalog (G05)* (The connectors used for DeviceNet communications cables use screws to secure the wires.)

- 1,2,3... 1. Insert the cable into the cap, cable clamp, water-tight bushing, and cover.
2. Prepare the communications cable, referring to the procedure described under *Attaching Communications Cables* in 2-4-1 *Wiring and Installing Standard Connectors*.
3. When using shielded connectors, remove approximately 20 mm of the cable covering, and strip approximately 8 mm of the sheath from the signal lines and power lines (refer to the following diagram). Do not remove too much of the covering. Removing excessive cable covering may result in a short circuit or the expected water-tight capabilities will not be provided.
4. Insert the signal lines, power lines and shield wire into the contact block holes, making sure the terminal numbers are correct.

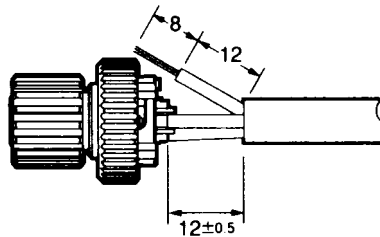

5. Tighten the contact block's line set screws on each of the lines. Tighten the set screws to a torque of between 0.15 and 0.2 N·m using a special screwdriver.

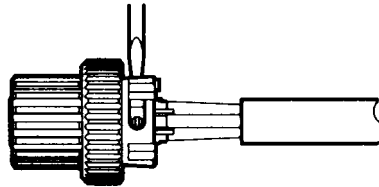

Note Use the OMRON XW4Z-00B Screwdriver to tighten the line set screws of the shielded connector for custom cable assembly.

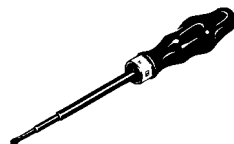

6. Insert the contact block into the cover, aligning the positioning key (triangular mark) on the contact block with the triangular mark on the cover.
7. Tighten the cover lock so that the contact block and cover are firmly joined. Tighten to a torque of between 0.39 and 0.49 N·m.
8. Tighten the cap to the cover firmly, making sure the water-tight bushing and cable clamp are inserted properly. Tighten to a torque of between 0.39 and 0.49 N·m.

2-4-4 Connecting to T-branch Taps and Nodes

Align the cable connector with the socket on the T-branch Tap or Node as shown in the following diagram and fully insert the connector into the socket. Tighten the set screws to secure the connection. Tighten the screws to a torque of between 0.25 and 0.3 N·m.

- Example 1: Connecting to a DCN1-1C T-branch Tap

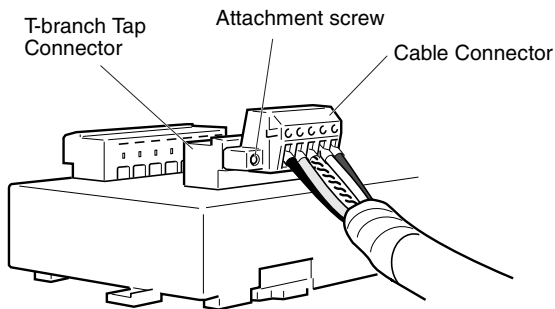

- Example 2: Connecting to a CV-series Master Unit

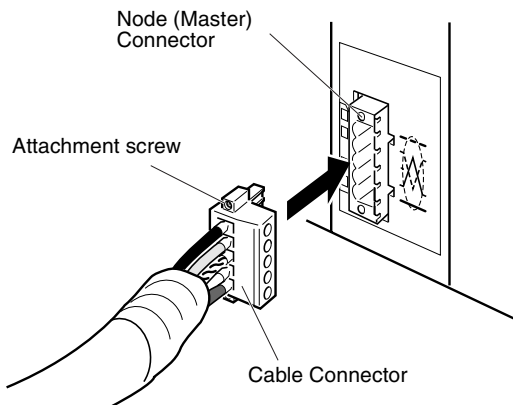

- Note**
1. To avoid damaging the cable or breaking wires, leave some slack in the cable so that it won't be pulled too hard or bent too sharply when connecting. Also, never put heavy objects on top of the cable.
 2. The orientation of the node connector is different in some other Units. Verify that the cable's wire colors match the colors on the label next to the node connector.

2-4-5 Flat Cable I (Standard)

Preparing DCN4-TR4-1 Flat Connector Sockets

Component Names

Cover

Housing

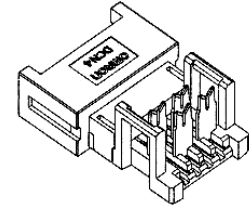
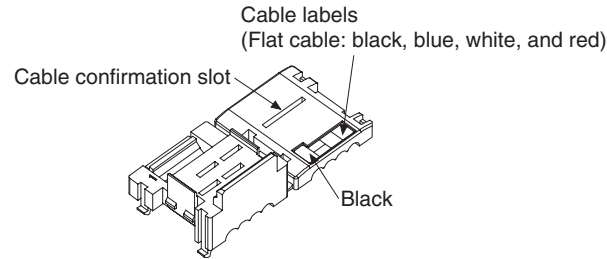

■ Cutting the Cable (when Extending Cable or Connecting Terminating Resistance)

Cut the cable perpendicular to the length.

To prevent short-circuits, cut the cable with a sharp blade, such as wire cutters, and be sure that there are no whiskers on the wires.

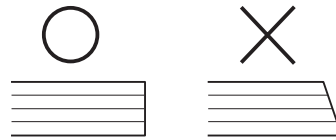

■ Setting the Cable Stopper (when Extending Cable or Connecting Terminating Resistance)

A stopper must be set in advance when extending a line or connecting terminating resistance.

Close the cover, secure the hooks, and then press down on the cable stopper until it clicks into place.

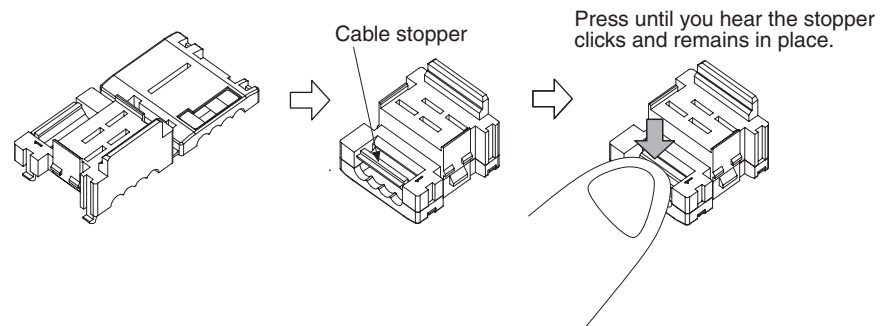

■ Attaching the Cable

T-branch Connections

- 1,2,3... 1. Align the cable labels and cable colors and insert the cable into the cover.

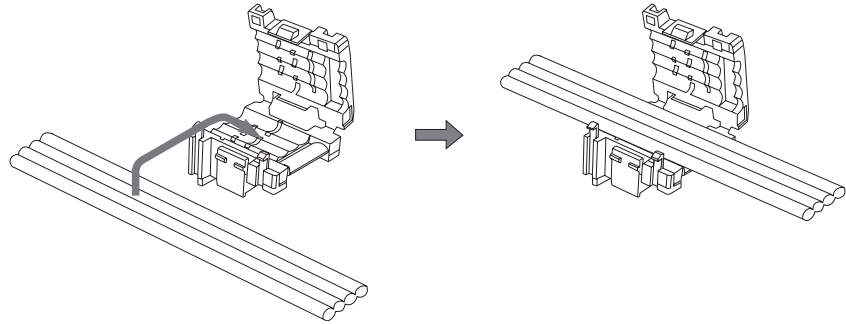

2. Hold the cable and secure it with the hooks.

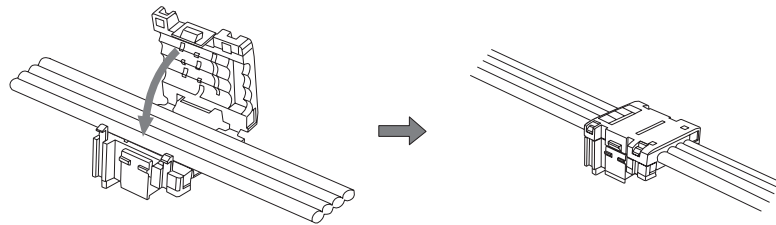

Line Extensions and Terminating Resistance

Insert the cable end all the way into a cover with the cable stopper already set.

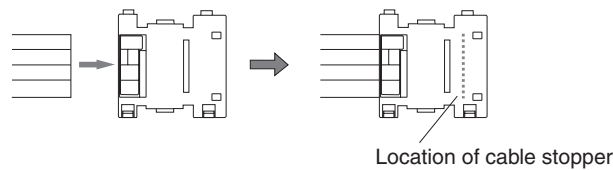

■ Attaching the Housing

Confirm that the cable labels and cable colors match and then temporarily secure the housing to the cover.

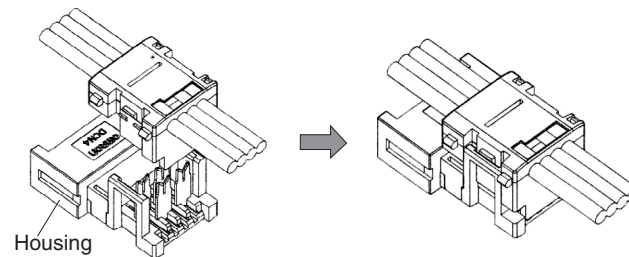

Note The housing cannot be removed from the cover once it has been attached. The connector may be damaged if the housing is forcefully removed.

■ Pressure-welding the Connector

The connector is pressure-welded using the DWT-A01 Pliers.

- 1,2,3... 1. As shown below, align the center (see arrows) of the connector cover with the center of the pressure-welding block on the Pliers.

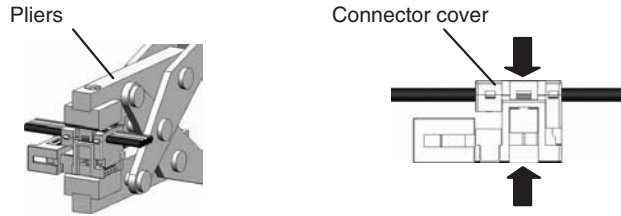

2. Squeeze firmly on the Pliers until the lock on the connector clicks into place.

Note

- (1) Do not pressure-weld the connector cover at the edges.
- (2) Do not pressure-weld the connector cover at the back of the pressure-welding block.
- (3) Set the connector in the correct orientation.

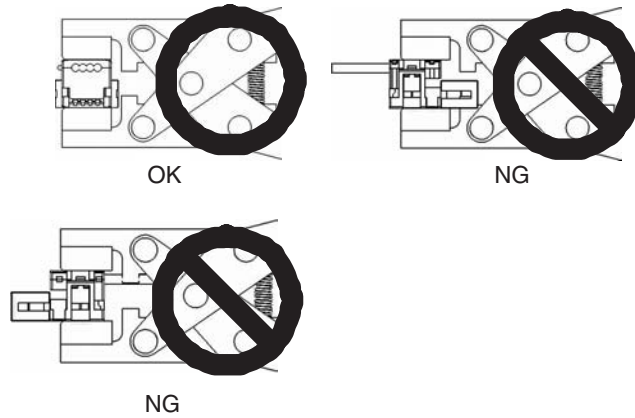

3. After attaching the cable, confirm that it is properly pressure-welded as shown below.

Be sure the connector is locked on both the left and right sides.

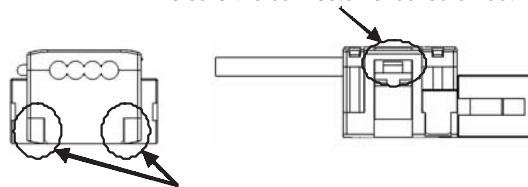

Be sure there are no gaps here.

Preparing DCN4-BR4 Flat Connector Plugs

Component Names

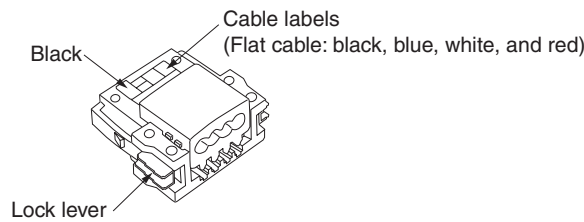

■ **Cutting the Cable**

Cut the cable perpendicular to the length.

To prevent short-circuits, cut the cable with a sharp blade, such as wire cutters, and be sure that there are no whiskers on the wires.

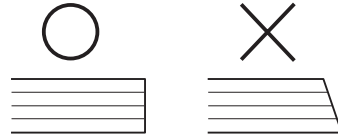

■ Attaching the Cable

Align the cable labels and cable colors and insert the cable.

Confirm that the cable is inserted all the way to the back. (The cover is semi-transparent.)

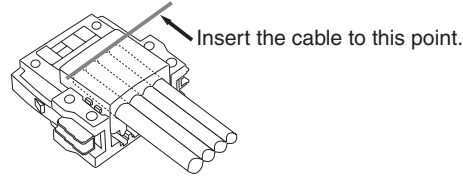

■ Insert the cable to this point.

The connector is pressure-welded by using the DWT-A01 Pliers.

- 1,2,3... 1. As shown below, align the center (see arrows) of the connector cover with the center of the pressure-welding block on the DWT-A01 Pliers.



2. Squeeze firmly on the Pliers until the lock on the connector clicks into place.

Note

- (1) Do not pressure-weld the connector cover at the edges.
- (2) Do not pressure-weld the connector cover at the back of the pressure-welding block.
- (3) Set the connector in the correct orientation.

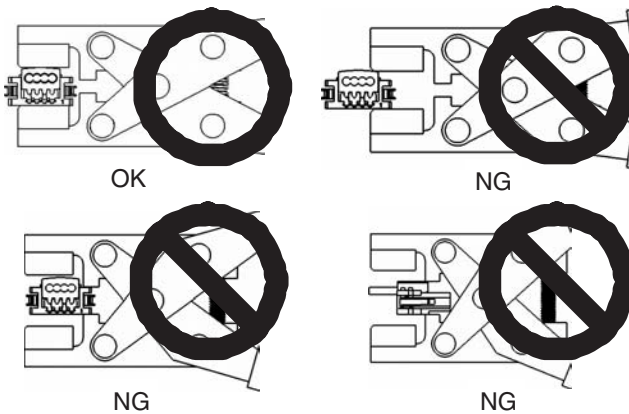

- After attaching the cable, confirm that it is properly pressure-welded as shown below.

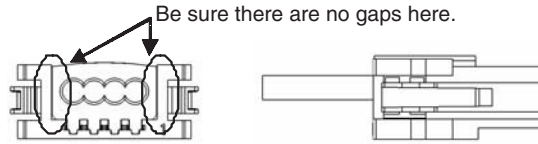

Preparing and Attaching a DCN4-BR4D Thin Cable-Flat Cable Conversion Connector

Component Names

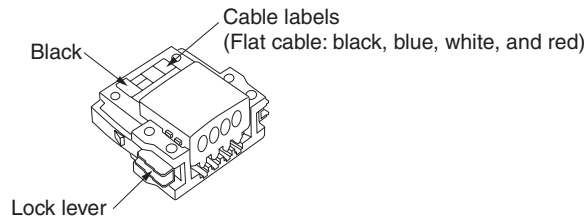

■ Cutting the Cable

Use the following procedure to prepare and connect the communications cables to the connectors.

- Strip about 30 mm of the cable sheathing, being careful not to damage the woven shield just below the sheathing. Do not remove more than about 30 mm; removing too much of the covering can result in short circuits or allow noise into the Network.

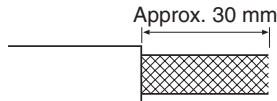

- Carefully peel back the woven shield. There is a bare shield wire under the woven shield as well as the signal lines and power lines. (The shield wire will be loose on the outside of the other lines, but it is stiffer than the woven shield and easy to identify by touch.)

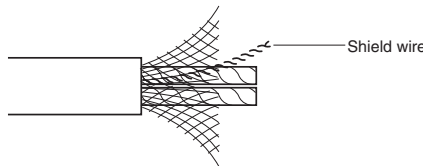

- Cut away the exposed woven shield, remove the aluminum tape from the signal and power lines, and remove the shield wire. Twist together the stranded wires of each signal and power lines.

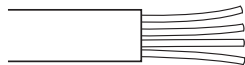

- Wrap the cable with vinyl tape or heat-shrink tubing.

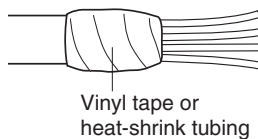

■ Attaching the Cable

Align the indications on the cable identification label with the cable colors and insert the cable. The cover is translucent, so it is possible to confirm that the cable has been inserted all the way in.

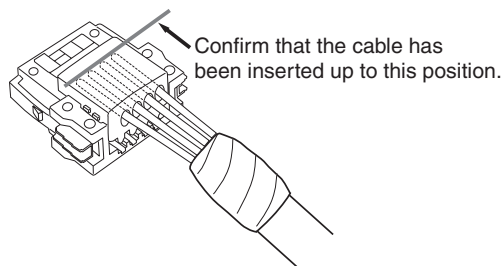

■ Pressure-welding the Connector

Use the DWT-A01 Pliers to pressure-weld the connector.

- 1,2,3... 1. As shown in the following diagram, align the center of the connector cover (see arrows) with the center of the pressure-welding block on the Pliers.

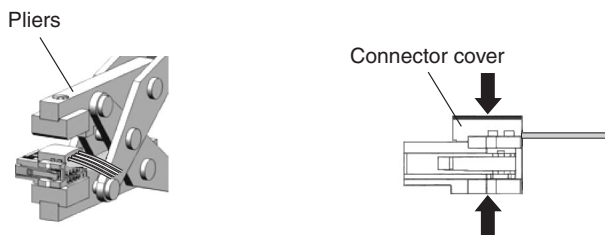

2. Squeeze firmly on the Pliers until the lock on the connector clicks into place.

- Note**
- (1) Do not pressure-weld the connector cover at the edges.
 - (2) Do not pressure-weld the connector cover at the back of the pressure-welding block.
 - (3) Set the connector in the correct orientation.

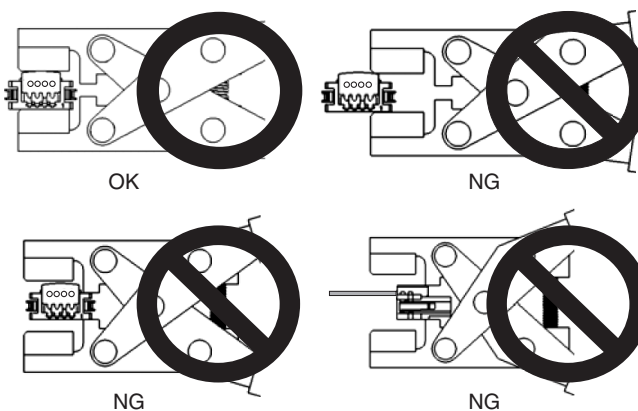

3. After attaching the cable, confirm that it is properly pressure-welded as shown below.

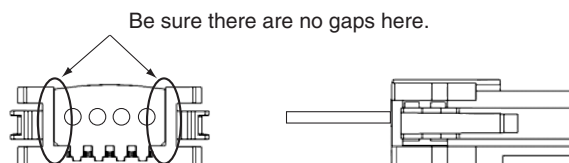

2-4-6 Connecting Shielded (Environment-resistive) Cables

Check that the connector (plug or socket) on the Shielded T-branch Connector or Environment-resistive Slave is the opposite of the connector (socket or plug) on the Cable, align the connectors, and insert the cable connector.

Insert the connector fully and tighten the connector by hand. Tighten Micro-size Connectors to a torque of between 0.39 and 0.49 N·m. Tighten Mini-size Connectors to a torque of between 0.7 and 0.8 N·m.

- Note**
- (1) Tighten the connector ring securely by hand. If the connector is not tightened sufficiently, it will not provide the specified level of environmental resistance and might become loose due to vibration.
Do not use a tool such as pliers to tighten the connector, because the tool can damage the connector.
 - (2) To avoid damaging the cable or breaking wires, leave some slack in the cable so that it won't be pulled too hard or bent too sharply when connecting. Also, never put heavy objects on top of the cable.
 - (3) The location of the connector and the type of connector (plug or socket) varies from device to device. Check the location and type of connector required before wiring the devices.

2-4-7 Wiring the Communications Power Supply

There are three ways to wire the communications power supply. The following table shows applications where each method can be used.

Method	Number of communications power supplies in Network		Total current consumption (See note 1.)			Connection method
	1	2 or more	Less than 3 A	3 A to 5 A	More than 5 A	
Connecting to a T-branch Tap	Yes	No	Yes	Yes	No	Attach V+ and V– wires to a connector.
Connecting to a T-branch Connector	Yes	No	Yes	Yes (See note 2.)	Yes (See note 2.)	Use just the V+ and V– from a thin cable with shielded connector on one end.
Connecting to a Power Supply Tap	Yes	Yes	Yes	Yes	Yes	Wire V+ and V– wires to terminal block.

- Note**
- (1) The maximum current is 5 A for a T-branch Tap and 8 A for a T-branch Connector (3 A through a micro-size connector). Determine the current consumption for all nodes in both directions.
 - (2) A DCN2-1 T-branch Connector (for thin cable only) cannot be used because the maximum current is 3 A. Also, when using a DC3-12 T-branch Connector that can connect to thin cable and thick cable, do not exceed 3 A through the thin cable.

Connecting to a T-branch Tap

Insert the communications power supply lines (V+ and V- wires) to the connector holes where the communications cable's V+ (red) wire and V- (black) wire are normally connected, as shown in the following diagram.

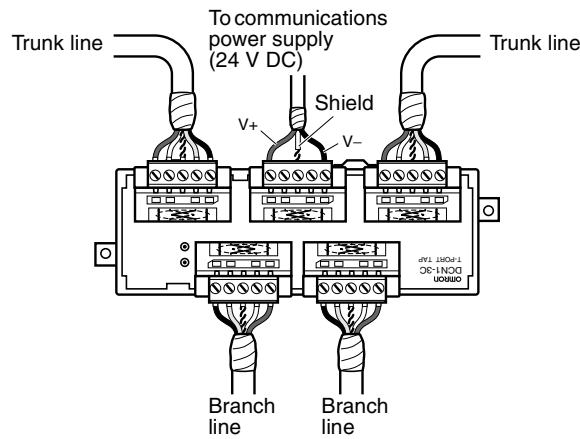

Connecting to a T-branch Connector

Connect the communications power supply lines (V+ and V- wires) to the V+ (red) wire and V- (black) wire of a communications cable connected to the T-branch Connector, as shown in the following diagram. This example shows a DCN2-1 T-branch Connector, but the connection method is the same for other T-branch Connectors.

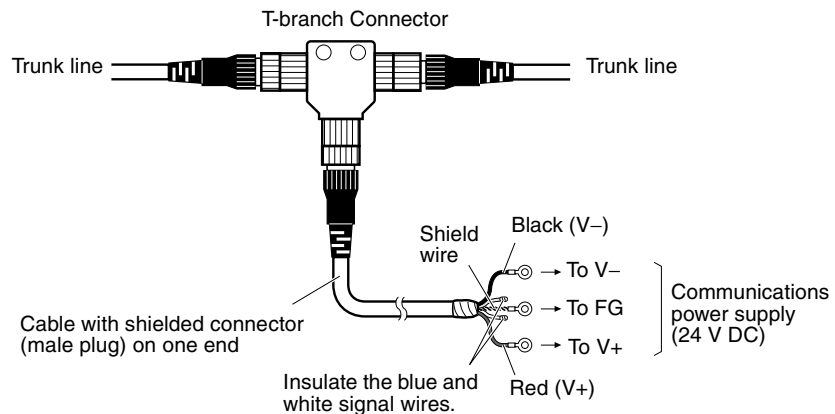

Connecting to a DCN1-1P Power Supply Tap

Insert the communications power supply lines to the terminal block provided for the communications power supply input, as shown in the following diagram.

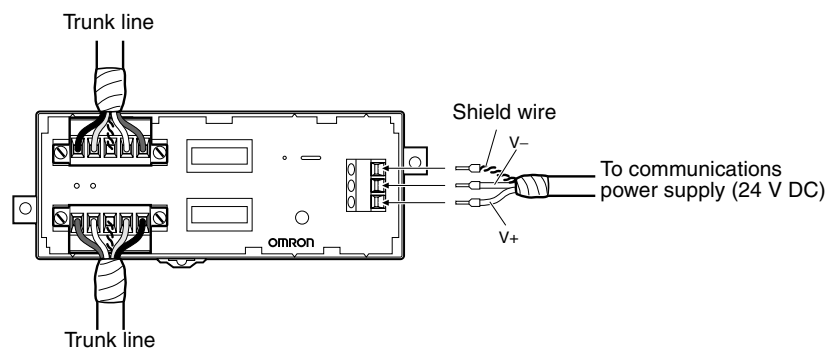

Note Use a separate power supply for DeviceNet communications. The power supply can be shared, however, if noise interference is not generated by the internal circuit power supply, Sensor power supply, or other source.

Note The following cable crimp terminals are recommended.

- Phoenix Contact, AI Series

Wire size	Crimp terminal	Crimping Tool
AWG24	AI 0.25-6BU	CRIMPFOX ZA3
AWG22	AI 0.34-6TQ	
AWG20	AI 0.5-6WH	
AWG18	AI 0.75-6GY	
AWG16	AI 1.5-6BK	

2-4-8 Connecting the Terminating Resistors (Terminators)

Use any of the following methods to terminate the ends of the trunk line.

Connecting to a T-branch Tap or Power Supply Tap

Connect a Terminating Resistor to the Tap.

A Terminating Resistor is provided with each OMRON T-branch Tap or Power Supply Tap. Insert the Terminating Resistor in the T-branch Tap as shown in the following diagram. The resistor can face in either direction.

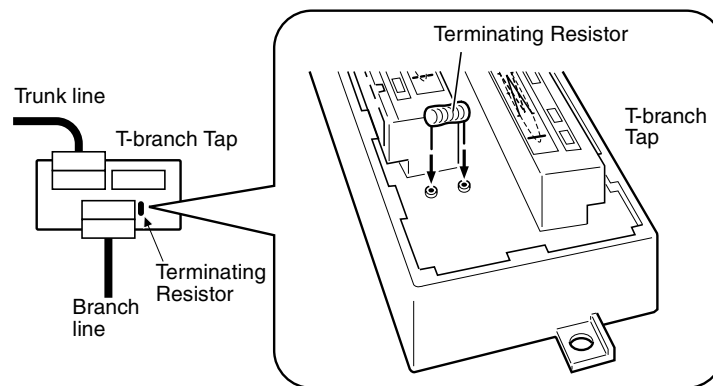

Connecting to a T-branch Connector

Connect one of the following terminators (Connector with Terminating Resistance) to a T-branch Connector at the end of the trunk line.

Terminator model	Description
DRS2-1	Micro-size (M12) Connector (male plug)
DRS2-2	Micro-size (M12) Connector (female socket)
DRS3-1	Mini-size Connector (male plug)

The Terminators have a built-in Terminating Resistor. These Terminators can be used with T-branch Connectors only.

Tighten the Terminators securely by hand. Tighten a Micro-size Terminator to a torque of between 0.39 and 0.49 N-m. Tighten a Mini-size Terminator to a torque of between 0.7 and 0.8 N-m.

This example shows a DCN2-1 T-branch Connector, but the connection method is the same for other T-branch Connectors.

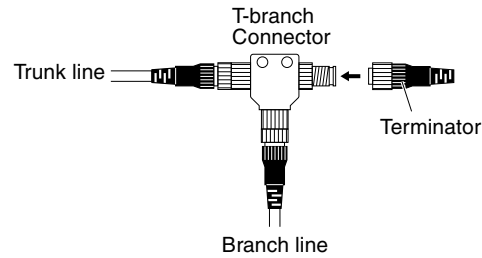

Connecting to a Terminal Block

When a node is connected directly to the end of the trunk line and there isn't enough space to connect a T-branch Tap, a Terminal-block Terminating Resistor can be connected with a multi-drop.

A 121 Ω terminating resistor is built into the DRS1-T Terminal-block Terminating Resistor. To connect the cable to the Terminating Resistor, attach crimp terminals to the signal wires and securely screw the terminals to the Terminal-block Terminating Resistor.

Note Use the DeviceNet cable for the connection to the DRS1-T Terminal-block Terminating Resistor and keep the cable length less than 1 m.

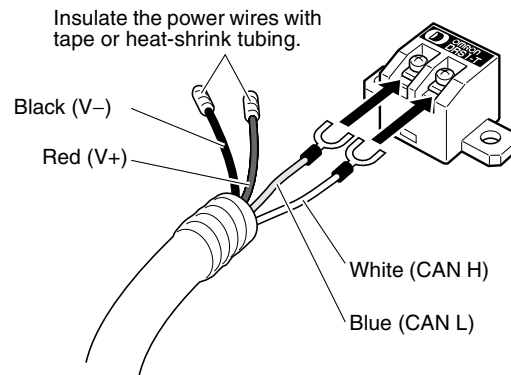
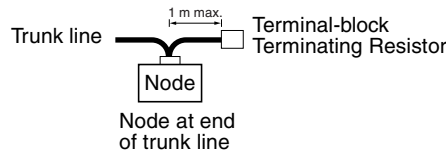

Use standard M3 crimp terminals and tighten to a torque of between 0.3 and 0.5 N·m.



Caution To avoid damaging the cable or breaking wires, leave some slack in the cable so that it won't be pulled too hard or bent too sharply when connecting. Also, never put heavy objects on top of the cable.

Flat Cable

Attach a DCN4-TM4 Terminating Resistor to the DCN4-TR4-1 Flat Connector Socket connected to Communications Cable.

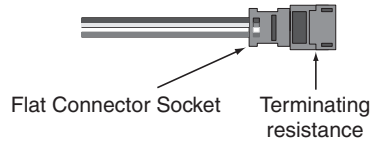

• Installation Method

Push in the Terminating Resistor until it clicks into place.

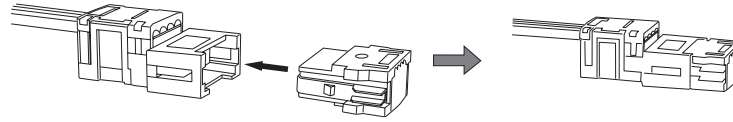

Note To remove a Terminating Resistor once it has been connected, press in on the catches on both sides and pull it out.

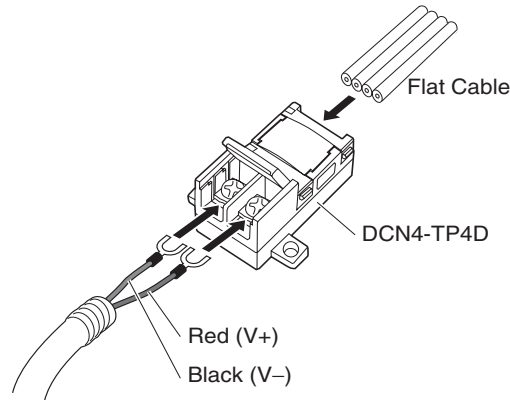

To supply communications power from the terminal block, use a DCN4-TP4D Flat Cable Terminal Block with Terminating Resistance.

2-4-9 Grounding the Network

Use any of the following methods to ground the network. The DeviceNet network must be grounded at one location and one location only.

Grounding the Shield (S) Terminal of a Power Supply Tap

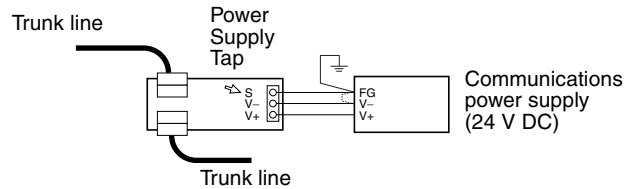

Grounding a T-branch Tap or Node Connector

The ground wire can be inserted into the connector together with the communications cable's shield wire and both locked in place with the set screw, as shown in the following diagram.

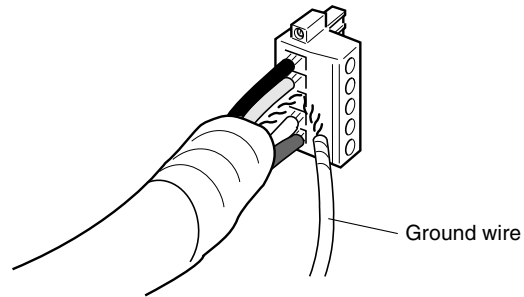

Grounding an Unused T-branch Tap Connector

The ground wire alone can be inserted in the connector of an unused T-branch Tap connector, as shown in the following diagram.

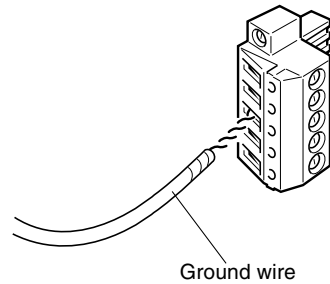

- Note**
1. A ground of 100 Ω max. is recommended.
 2. When an acceptable ground of 100 Ω max. is available, connect the communications power supply's V- and FG terminals.
 3. When an acceptable ground of 100 Ω max. is not available, do not connect the communications power supply's V- and FG terminals. In this case, connecting the V- and FG terminals may introduce noise into the network.

2-5 Minimizing Noise in the Network

2-5-1 Precautions to Prevent Noise

- To prevent inductive noise, separate the communications lines, PLC power supply lines, and other power lines. In particular, be sure to keep the power lines for inverters, motors, regulators, and contactors at least 300 mm away from both the communications lines and the power supply lines. Also, provide separate conduits or ducts for the communications lines and power lines.

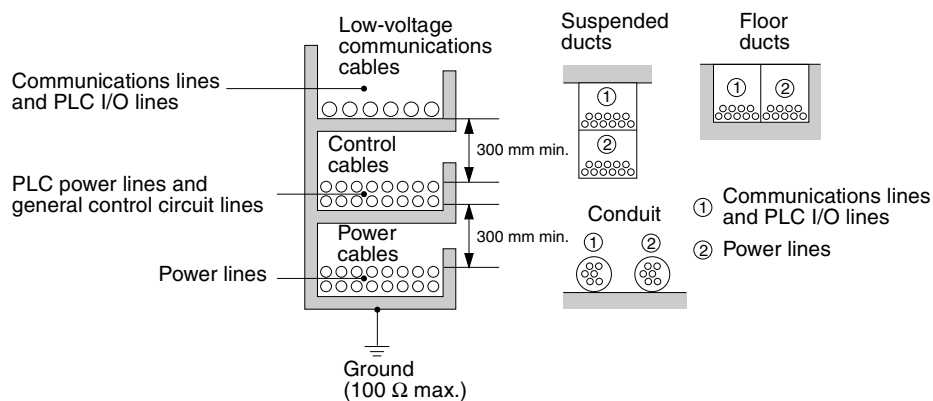

- Make the power supply lines to the control panel as short as possible, use heavy-gauge wire, and ground the power supply properly (100 Ω max.)
- Avoid installing any DeviceNet devices in a control panel that contains high-voltage devices.
- Install surge suppressors on devices that generate noise, particularly devices that have an inductive component such as motors, transformers, solenoids, and magnetic coils.

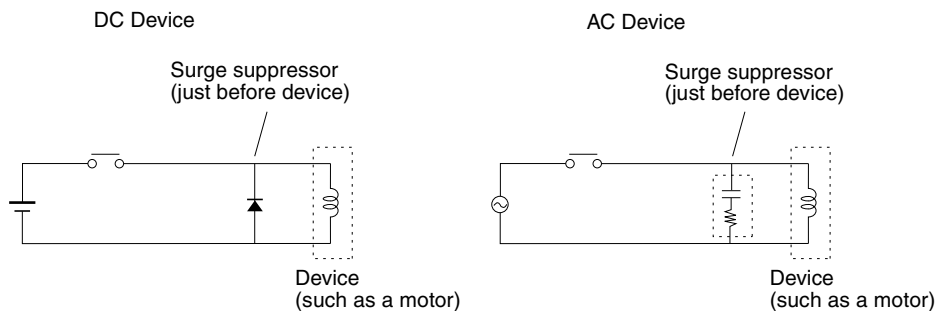

- If a surge suppressor cannot be installed, installing a ferrite core directly next to the device's contacts, such as a contactor may be effective.

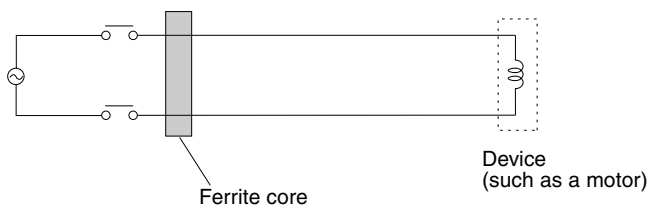

- Noise emanating from the communications cable can be reduced by installing a ferrite core on the communications cable within 10 cm of the DeviceNet Master Unit.

Ferrite Core (Data Line Filter):
 Nisshin Electric Co, Ltd. model 0443-164151 or equivalent

Inductance specifications	
25 MHz	100 MHz
156 Ω	250 Ω

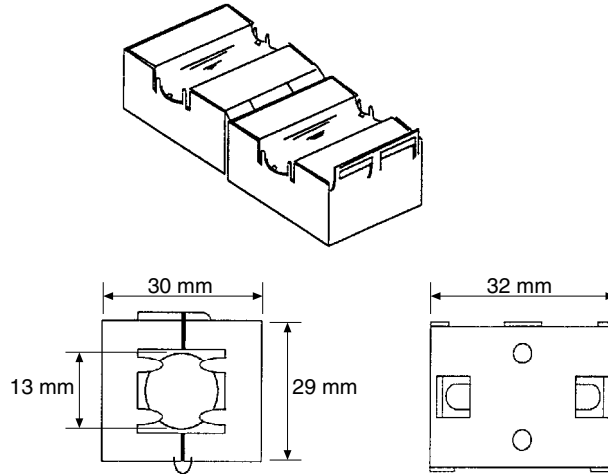

- Since noise currents often flow through metallic equipment (such as casings), the communications cables should be placed as far away from metallic equipment as possible.
- Ground the communications cable to 100 Ω max. with a ground wire that is as short as possible.
- Ground the shielding wire on the communications cable at one point. If the same ground is used for the communications cable and communications power supply, there is a possibility that noise may be transmitted through the ground line to the communications line. In order to avoid this, be sure that the power line ground and the grounds for the communications cables and the communications power supply are located as far from each other as possible.
- Insert a line filter on the primary side of the communications power supply.
- When there are two or more communications power supplies, ground the shielding wire at the Power Supply Tap near the center of the communications cable. Do not ground the shielding wire at more than one place.
 (In the following diagram, "PS" indicates a communications power supply.)

Network with 1 Communications Power Supply

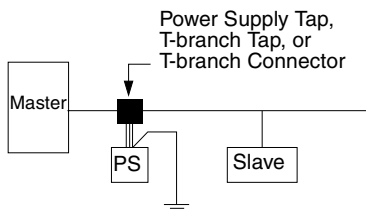

Network with 2 or more Communications Power Supplies

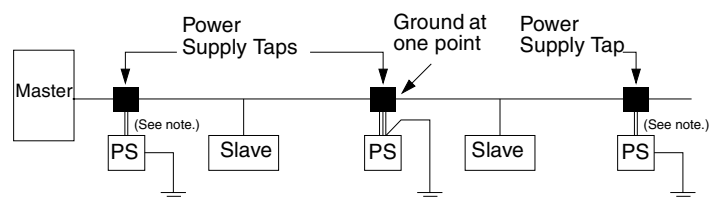

Note Do not connect the Power Supply Tap's shield (S) terminal to the communications power supply's FG terminal at these two Power Supply Taps.

Considerations when Using Flat Cable

To prevent unstable operation due to interference when using flat cable in multiple DeviceNet systems, keep each flat cable at least 5 mm apart from any other flat cable.

2-5-2 Correcting Malfunctions due to Noise

When noise is thought to be the cause of a malfunction in the DeviceNet network, the following countermeasures may be effective.

Problems with the Communications Cable Shielding

Isolate the communications cable shielding wire by disconnecting it from the ground.

Disconnecting the ground will reduce the noise transferred from the ground to the communications cable. This countermeasure also reduces the noise current that flows in the shield wire.

Problems with the Communications Power Supply

Isolate the communications power supply.

This countermeasure reduces the noise transferred from the communications power supply ground to the communications cable and the noise current that flows in the communications cable. A switching power supply is usually connected to the case with capacitors as shown below, so the power supply itself must be insulated from the control board as well as being disconnected from the FG terminal.

Typical Switching Power Supply Construction

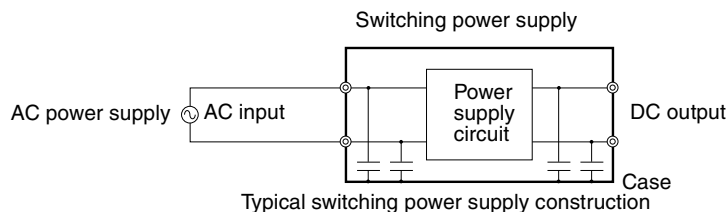

Isolating the Communications Power Supply

Example 1:
Isolating an S82J Power Supply

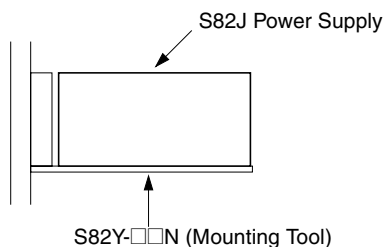

Example 2:
Isolating another Power Supply

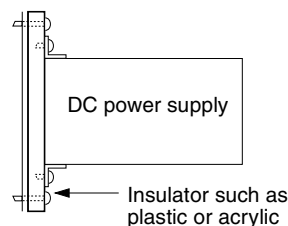

2-6 Operational Checklist

Category	Item	Check	Result		
Network configuration and wiring	Connectors	Are the connectors and cables to the Master connected correctly? (Do the wire colors match the colors next to the Master's DeviceNet connector?)	Yes	No	
		Are the connectors and cables to the Slaves connected correctly? (Do the wire colors match the colors next to the Slaves' DeviceNet connectors?)	Yes	No	
		Are the connectors securely connected?	Yes	No	
		Is there a possibility that the cable connectors will be pulled out because of the cable weight?	Yes	No	
		If the connectors have attachment screws or mounting brackets, are the screws/brackets tightened properly?	Yes	No	
	Terminators	Have Terminating Resistors been connected at both ends of the trunk line?	Yes	No	
		Are the specified Terminating Resistors being used?	Yes	No	
		If a T-branch Tap is being terminated, is the Terminating Resistor seated properly in the T-branch Tap's socket?	Yes	No	
	Max. network length	Is the length of the network within specifications?	Yes	No	
	Branch line length	Are all branch lines 6 m or shorter?	Yes	No	
		Is the total branch line length within specifications?	Yes	No	
	Cables	Can the cable supply the current required by all of the nodes that are connected?	Yes	No	
		Is the proper DeviceNet cable being used?	Yes	No	
		Are the cables separated from any power or high-voltage lines?	Yes	No	
		Have the cables been handled carefully, without excessive force?	Yes	No	
	Shield wire ground	Is the network be grounded in only one location?	Yes	No	
		Is a separate ground line used? (Is the ground line separated from any power line ground?)	Yes	No	
	Other	Are there any devices in the network that are not DeviceNet products?	Yes	No	
	Devices supplied by communications power supply	Power supply capacity	Has the power supply requirement been calculated using each node's current consumption?	Yes	No
			Can the power supply handle the inrush current when the system is started?	Yes	No
Isolation		Is the DC output isolated from the AC input in the power supply?	Yes	No	

SECTION 3

Communications Power Supply Methods

This section explains the various considerations involved in providing a communications power supply.

3-1	Basic Concepts	88
3-2	Flowchart: Determining Power Supply Requirements	89
3-2-1	Communications Power Supply	89
3-3	Locating the Power Supply	90
3-3-1	Power Supply Layout Patterns	90
3-3-2	Main Factors for Determining the Power Supply Location	91
3-3-3	Calculating the Power Supply Location	91
3-4	Step 1: Evaluating the Configuration with Graphs	92
3-4-1	Simple Evaluation of Power Supply Location from a Graph	93
3-4-2	Modifying the Configuration	93
3-5	Step 2: Evaluating the Configuration with Calculations	96
3-5-1	Formulae for Calculating the Voltage Drop	97
3-5-2	Modifying the Configuration	98
3-6	Step 3: Splitting the System into Multiple Power Supplies	101
3-6-1	Splitting the Power Supply System	101
3-6-2	Configuration of the Power Supply Tap	101
3-6-3	Internal Circuits in the Power Supply Tap	101

3-1 Basic Concepts

- The communications power supply must be 24 V DC.
- Always supply the power from the trunk line.
- When providing power to several nodes from one power supply, try to locate the power supply near the center of the nodes.
- Provide power through Power Supply Taps. It is possible to use a T-branch Tap or T-branch Connector instead of a Power Supply Tap when there is one communications power supply in the system and the current consumption is within the specifications of the T-branch Tap or T-branch Connector. Refer to *2-3-4 T-branch Taps* or *2-3-5 Shielded T-branch Connectors* for details on the current limitations of these components.
- The power supply capacity for cables is restricted to 8 A for Thick Cables, 3 A for Thin Cables, and 5 A for Flat Cables.
- Environment-resistive Slaves are wired with Thin Cable, so the current through a cable to an Environment-resistive Slave is limited to 3 A.
- A single network is usually supplied by one power supply, however, it is possible to have more than one power supply when power supply requirements cannot be met with a single power supply. (See *3-6 Step 3: Splitting the System into Multiple Power Supplies*.)
- Provide some extra power supply capacity in the network to allow for future expansion and extend the life of the power supply.
- Turning OFF the communications power supply during operation can cause errors in the other nodes if the other power supplies are left ON.
- The current capacity of a branch line ranges from 0.75 to 3 A, depending on its length. Use the following equation to calculate the current capacity. (The maximum current capacity of a branch line is 3 A, even if the branch line is shorter than 1.53 m.)

$$I = 4.57/L$$

I: Permissible current (A)
L: Length of the branch line (m)

3-2 Flowchart: Determining Power Supply Requirements

3-2-1 Communications Power Supply

Use the flow chart below to determine the appropriate method for supplying the communications power supply on the trunk line. The current in each branch line must not exceed the maximum value calculated with the equation on page 88.

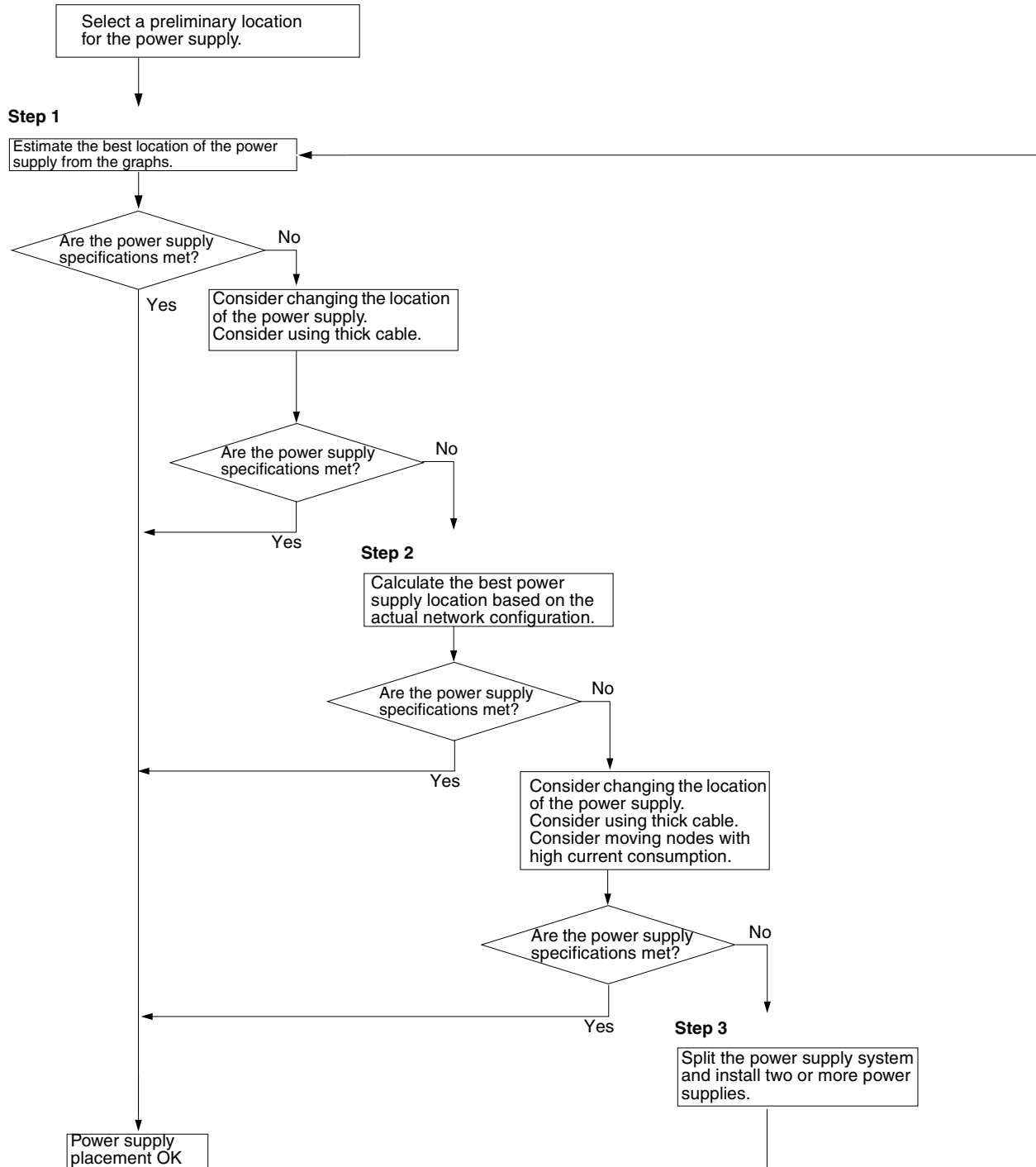

3-3 Locating the Power Supply

3-3-1 Power Supply Layout Patterns

The power supply can be set up in the configurations shown below. In general, select either configuration 1 or 2 (a single power supply configuration.)

Use configuration when power supply requirements cannot be met with configuration 1 or 2. For more details on each configuration, refer to sections 3-4 Step 1: Evaluating the Configuration with Graphs through 3-6 Step 3: Splitting the System into Multiple Power Supplies.

Configuration 1: Supplying Power to Nodes in Both Directions

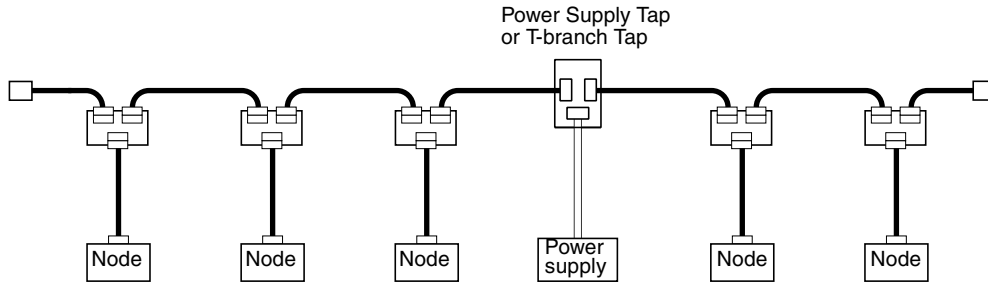

Configuration 2: Supplying Power to Nodes in One Direction

- Note**
- (1) Configuration 1 is recommended when a single power supply is being used to provide power to many nodes.
 - (2) When flat cable is used, power can be supplied from a DCN4-TP4D Flat Cable Terminal Block with Terminating Resistance.

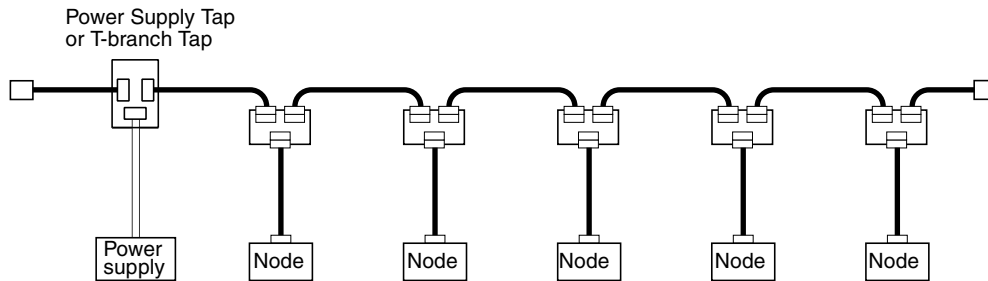

Configuration 3: Dividing the Power Supply System

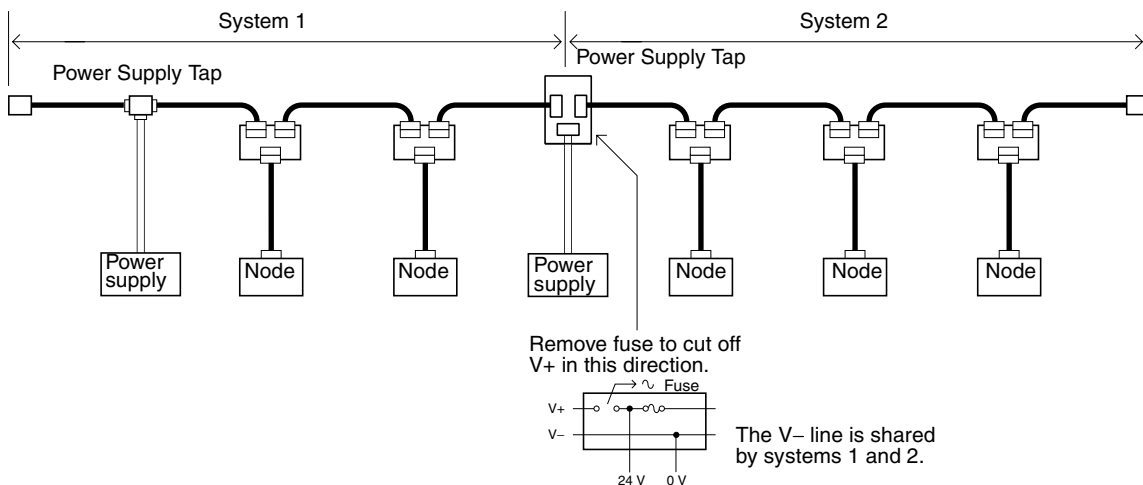

Note If the current carried by a thick cable exceeds 8 A even after the power supply configuration has been changed, the power supply requirements cannot be met with a single power supply and multiple power supplies must be used.

In configuration 1, the power can be supplied to the trunk line in both directions as long as the current in each direction is 8 A or less when using thick cable. Consequently, it is possible to have a configuration with a total current consumption up to 16 A. Change to thick cable if thin cable is being used in the trunk line and the current through the thin cable exceeds 3 A.

3-3-2 Main Factors for Determining the Power Supply Location

Determine whether or not the current can be supplied normally by finding the current capacity required by each node and the voltage drop in the cables to be used to provide power. Calculate the values below in advance.

- The current required by each node
- The distance between the power supply and each node

3-3-3 Calculating the Power Supply Location

There are two methods to find the best location of the communications power supply on the trunk line.

1. Simple estimation from a graph
2. Calculation by formula (Calculate the voltage drop based on the current requirements of the nodes and the communications cable resistance.)

Each branch line must satisfy the equation on page 88, which shows the maximum current capacity of a branch line based on its length.

- The graph estimation assumes the worst case scenario from the standpoint of the power supply (the configuration that has the maximum voltage drop as shown in the diagram below), so any actual power supply configuration will be acceptable based on the graph estimation.

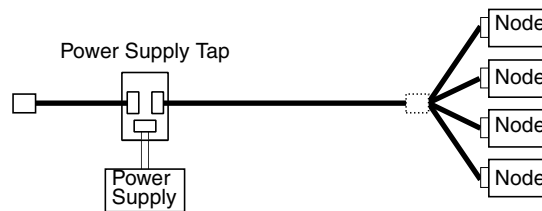

- Since the graph estimation assumes the worst case scenario, an actual network configuration may be acceptable even if the configuration is disallowed in the graph. Evaluate the configuration accurately by performing the calculations described in 3-5 Step 2: *Evaluating the Configuration with Calculations*.

Note When a single power supply is used to provide the communications power supply and the internal circuit supply, use the formula method to evaluate a hypothetical power supply location because it cannot be evaluated with the graphs. Refer to *Shared Communications and Internal Circuit Power Supply* on page 97 for details on this calculation.

3-4 Step 1: Evaluating the Configuration with Graphs

There is a voltage drop in a communications cable as current flows through the cable. The voltage drop increases in proportion to the length of the communications cable and the amperage of the current being carried.

The communications power supply at each node must be 11 V DC min. The following graph shows the maximum current that can be supplied through various lengths of cable while maintaining the minimum voltage required at the nodes. (The values in the graph provide some extra margin.)

Thick Cable

Distance (m)	0	25	50	100	150	200	250	300	350	400	450	500
Maximum current (A)	8.00	8.00	5.42	2.93	2.01	1.53	1.23	1.03	0.89	0.78	0.69	0.63

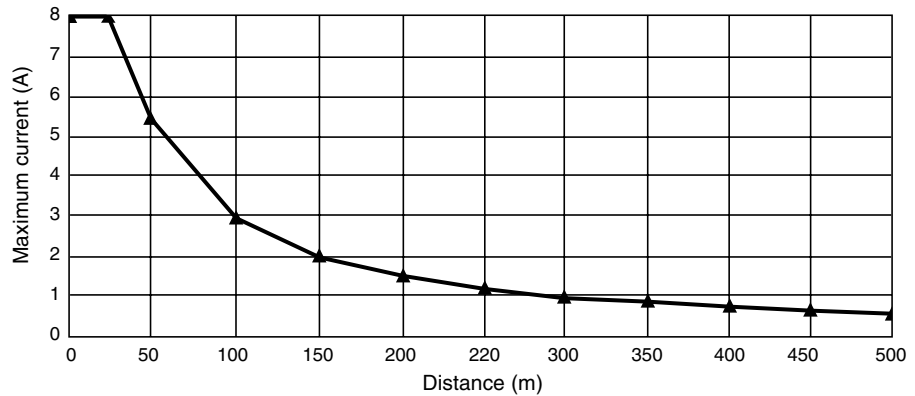

Thin Cable

Distance (m)	0	10	20	30	40	50	60	70	80	90	100
Maximum current (A)	3.00	3.00	3.00	2.06	1.57	1.26	1.06	0.91	0.80	0.71	0.64

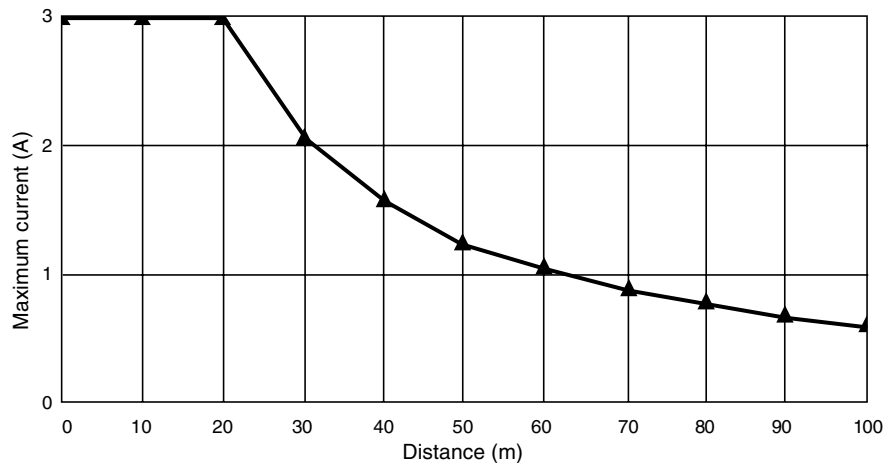

Flat Cable

Distance (m)	0	20	40	80	100	140	200	260	300
Maximum current (A)	5.00	5.00	5.00	2.75	2.21	1.58	1.11	0.85	0.74

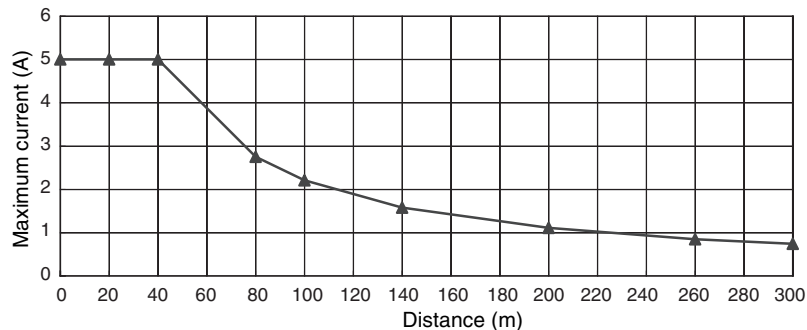
**3-4-1 Simple Evaluation of Power Supply Location from a Graph**

Check items 1 to 3 listed below for all of the nodes located in the same direction from the power supply. (If power is supplied in two directions, check these 3 items for all of the nodes in each direction.)

- 1,2,3...**
1. Calculate the total current consumption (I_A) of all the nodes to which communications power is to be supplied in one direction.
 2. Refer to the graph to find the maximum current flow (I_B) allowed in the cable based on the type of cable being used (thick or thin) and the distance from the power supply to the end of the trunk line.
 3. Compare the values (I_A and I_B) found in steps 1 and 2 above. If $I_A \leq I_B$, the power supply specifications are met and power can be supplied properly to all nodes.

Note Be sure to refer to the correct graph because the maximum current flow is different for thick and thin cables.

3-4-2 Modifying the Configuration

If the graph indicates that power cannot be supplied properly in one direction ($I_A > I_B$), use the following procedure to modify the communications power supply configuration.

- Move the communications power supply towards the center of the network so that there are nodes to both sides of it.
- If there are already nodes on both sides of the power supply, move the power supply in the direction that requires the higher current.
- If thin cable is being used, replace it with thick cable.

If power still cannot be supplied properly in one direction ($I_A > I_B$) after making the changes listed above, proceed to Step 2 and calculate the actual current requirements based on each node's position in the network and its current consumption.

Example 1:
Power Supply at the End of the Network

In this example, the power supply is at one end of a Network with a total length of 200 m of thick cable. The power supply is located on the end of the Network. The current consumption of the individual nodes is as follows:

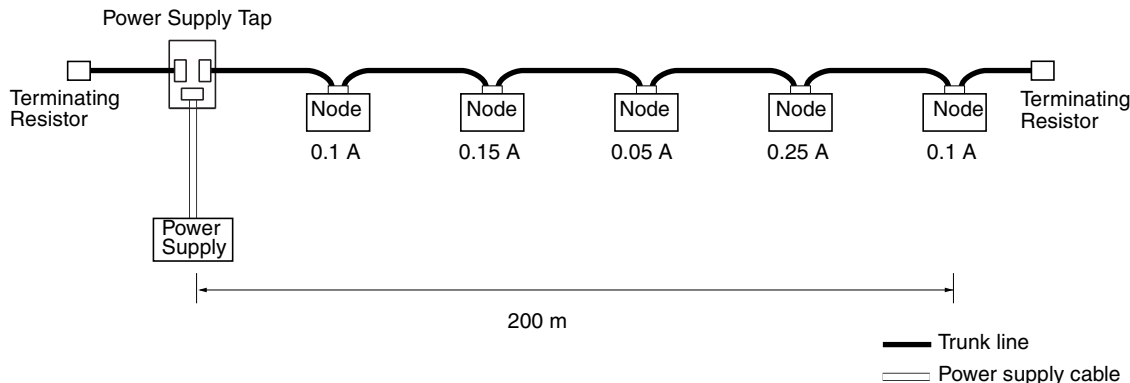

Total power supply length = 200 m
 Total current consumption = $0.1 + 0.15 + 0.05 + 0.25 + 0.1 = 0.65 \text{ A}$
 Maximum current for 200 m (see table for thick cable) = 1.53 A
 Because the total current consumption (0.65 A) is less than the maximum current (1.53 A), the power supply can be placed at the end of the network and supply current to all nodes.

Example 2:
Power Supply in the Center of the Network

In this example, the power supply is in the center of a Network with a total length of 240 m of thick cable. Because the power supply is in the center, the maximum permissible current can flow both to the left and right, so the power supply can supply twice as much current as it could when placed at the end of the network. The current consumption for individual nodes is as follows:

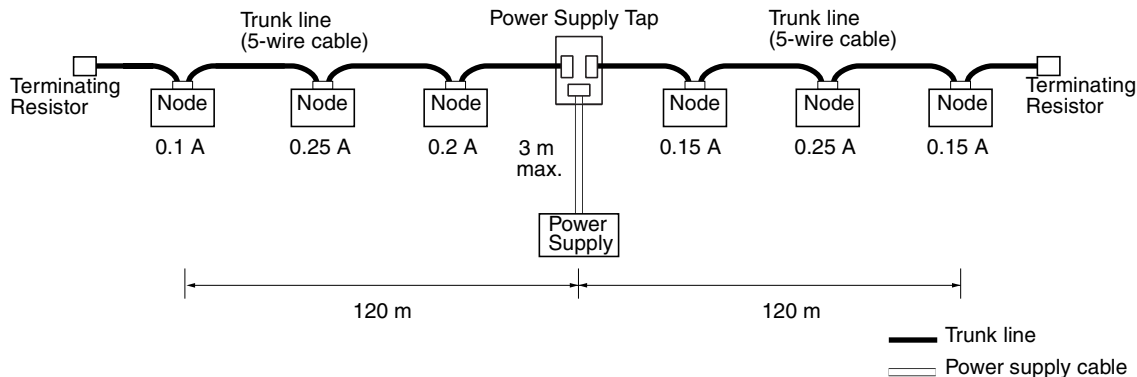

Total power supply length on left = Total power supply length on right = 120 m
 Total current consumption on left: $0.1 + 0.25 + 0.2 = 0.55 \text{ A}$
 Total current consumption on right: $0.15 + 0.25 + 0.15 = 0.55 \text{ A}$
 Maximum current on the left side (see table for thick cable) = approx. 2.5 A
 Maximum current on the right side (see table for thick cable) = approx. 2.5 A (using linear approximation between 100 to 150 m)
 Because the total current flow (0.55 A) is less than the maximum current (approx. 2.5 A) on both the left and the right sides, the power supply can be placed at the center of the network and provide power to all nodes.

Example 3:
Uneven Power Supply Distribution

In this example, the power supply is initially located in the center of a Network with a total length of 240 m of thick cable. The power supply is moved to one side because the current consumption is significantly higher on that side and the current flow to that side would be insufficient if the power supply were con-

nected in the very center of the Network. Placing it slightly off center allows power to be supplied properly to all nodes.

The current consumption for individual nodes is as follows:

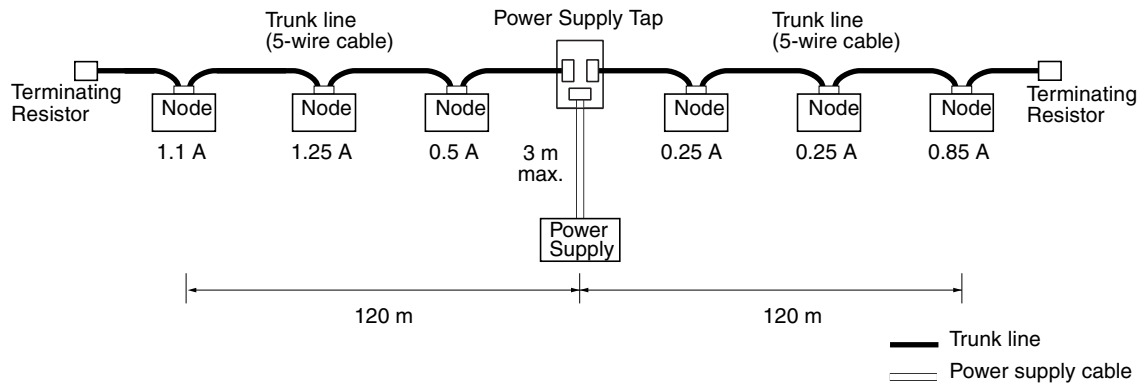

Total power supply length on left = Total power supply length on right = 120 m

Total current consumption on left: $1.1 + 1.25 + 0.5 = 2.85 \text{ A}$

Total current consumption on right: $0.25 + 0.25 + 0.85 = 1.35 \text{ A}$

Maximum current on the left side (see table for thick cable) = approx. 2.5 A

Maximum current on the left side (see table for thick cable) = approx. 2.5 A (using straight line approximation between 100 to 150 m)

Because the total current flow on the left side (2.85 A) is greater than the maximum current allowed on the left side (2.56 A), the power supply cannot supply current to all nodes properly when it is placed at the center of the network.

This problem can be corrected by moving the communications power supply as shown in the following diagram.

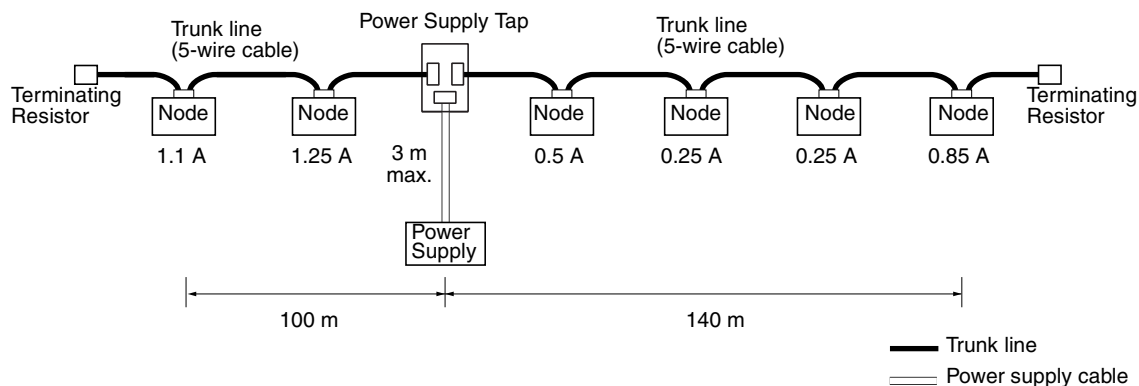

Total power supply length on left = 100 m

Total power supply length on right = 140 m

Total current consumption on left: $1.1 + 1.25 = 2.35 \text{ A}$

Total current consumption on right: $0.5 + 0.25 + 0.25 + 0.85 = 1.85 \text{ A}$

Maximum current for 100 m on the left (see table for thick cable) = 2.93 A

Maximum current for 140 m on the right (see table for thick cable) = 2.1 A (using straight line approximation between 100 to 150 m)

Because the total current flow on both the left and right sides is now less than the allowed maximum current, the power supply can be placed as shown in the diagram and supply current properly to all nodes.

3-5 Step 2: Evaluating the Configuration with Calculations

Proceed with this step if the best location for the power supply cannot be determined from the graphs. Unlike the graph method used in step 1, the calculation method described in this section does not assume a worst-case power supply configuration.

In DeviceNet, the maximum permissible voltage drop in one power supply line (+V or -V) is specified as 5 V based on the specified communications power supply voltage (24 V DC) and the input voltage of the communications power supply at each device (11 to 25 V DC). The evaluation in this step is based on the maximum 5 V voltage drop.

The maximum permissible voltage drop in the whole line is 5 V, with the maximum permissible voltage drop in the trunk line specified as 4.65 V and the maximum voltage drop in a branch line specified as 0.35 V.

Understanding the Voltage Drop

The following diagram shows the voltage drop effect due to the cable. In the DeviceNet network, the voltage drop over a communications cable is 5 V or less (allowing some extra margin), based on the specifications for the communications power supply device (24 V DC) and communications power supply at each node (11 to 25 V DC).

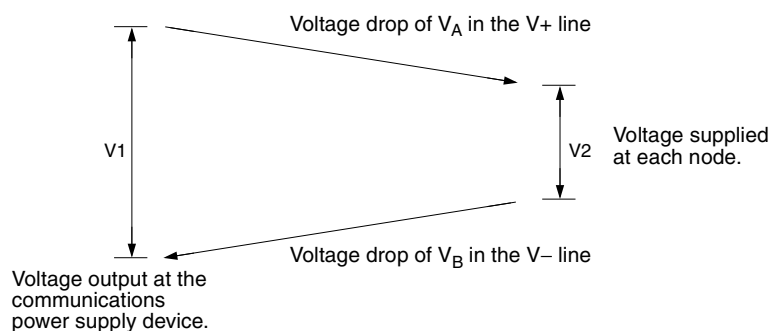

V_1 : Voltage supplied at the communications power supply device. Allow for ambient variations of the power supply voltage and take V_1 to be 23 V.

V_2 : Voltage supplied at each node. Allow an extra margin and take V_2 to be 13 V or greater.

V_A : Voltage drop at the power supply cable (+V).

V_B : Voltage drop at the power supply cable (-V).

In the DeviceNet network, $V_A \leq 5$ V and $V_B \leq 5$ V.

The voltage drop in the communications cables is specified as 5 V for a single power supply line (+V or -V). Of the permissible maximum voltage drop within the system (5 V), the permissible voltage drop in the trunk line is 4.65 V and the permissible voltage drop in a branch line is 0.35 V.

Note The explanation above is for the communications power supply only. When a single power supply must be used to supply both the communications power supply and the internal circuit power supply, the maximum voltage drop for a single power supply line (+V or -V) is just 1 V because the specifications for the internal circuit power supply are much stricter.

Of the permissible maximum voltage drop for a single power supply line (1 V), the permissible voltage drop in the trunk line is 0.65 V and the permissible voltage drop in a branch line is 0.35 V. (Refer to page 97 for details.)

3-5-1 Formulae for Calculating the Voltage Drop

Independent Communications and Internal Circuit Power Supplies

Determine the distance between the power supply and each node, and each node's current consumption for communications. (Refer to the table showing current consumption for various devices in *Appendix C Current Consumption of DeviceNet Devices*.) Evaluate whether the configuration satisfies the formula below. If the voltage drop is within the maximum value indicated, power can be supplied to the nodes properly with the configuration. Of course the current cannot exceed the maximum current capacity of the cable (8 A for thick cable and 3 A for thin cable.)

Formula 1: Calculating the Voltage Drop in the Trunk Line

$$\Sigma (L_n \times R_c + N_t \times 0.005) \times I_n \leq 4.65 \text{ V}$$

L_n : The distance between the power supply and node n (not including the length of the branch line)

R_c : Maximum cable resistance
(Thick cable: 0.015 Ω /m, thin cable: 0.069 Ω /m)

N_t : The number of Taps between node n and the power supply
(0.005 Ω = The contact resistance of a Tap)

I_n : The communications current required by node n

Shared Communications and Internal Circuit Power Supply

Note We recommend using separate power supplies for the communications power and the internal circuit power. (For details, refer to *2-2-9 Sharing the Communications and Internal Circuit Power Supply*.)

The allowed voltage ranges for the communications power supply and internal circuit power supply are significantly different, as shown below.

Communications power supply voltage range: 11 to 25 V DC

Internal circuit power supply voltage range: 24 V DC +10% to -15%

The lowest permissible voltage is 11 V DC for the communications power supply, whereas it is 21 V DC (including the extra margin) for the internal circuit power supply. If the internal circuit power is supplied by the communications power supply, the maximum permissible voltage drop due to cable resistance is much lower than it would be if the power supplies were separate.

When the output voltage fluctuation of the communications power supply is taken into account and 23 V (the lower end of the fluctuation range) is used as the power supply output voltage, the maximum permissible voltage drop in a single power supply line is $(23 \text{ V} - 21 \text{ V}) / 2 = 1 \text{ V}$. The permissible voltage drop can be subdivided into the max. permissible voltage drop in the trunk line of 0.65 V and the max. permissible voltage drop in a branch line of 0.35 V.

Determine the distance between the power supply and each node, and the total current consumption (communications and internal circuit power) for each node. There's no need to take into account the internal power supply current consumption of the Master Unit. (Refer to the table showing current consumption for various devices in *Appendix C Current Consumption of DeviceNet Devices*.)

Evaluate whether the power supply configuration satisfies the formula below. If the voltage drop is within the maximum value indicated, power can be supplied to the nodes properly with the configuration. Of course the current cannot exceed the maximum current capacity of the cable (8 A for thick cable and 3 A for thin cable.)

Formula 2: Calculating the Voltage Drop in the Trunk Line

$$\Sigma [(Ln \times Rc + Nt \times 0.005) \times In] \leq 0.65 \text{ V}$$

Ln: The distance between the power supply and node n (not including the length of the branch line)

Rc: Maximum cable resistance
(Thick cable: 0.015 Ω/m, thin cable: 0.069 Ω/m)

Nt: The number of Taps between node n and the power supply
(0.005 Ω = The contact resistance of a Tap)

In: The total current (communications current and internal circuit current) required by node n

3-5-2 Modifying the Configuration

If the result of formula 1 or formula 2 indicates that power cannot be supplied properly, use the following procedure to modify the communications power supply configuration.

- Move the communications power supply towards the center of the network so that there are nodes to both sides of it.
- If there are already nodes on both sides of the power supply, move the power supply in the direction that requires the higher current.
- If thin cable is being used, replace it with thick cable.
- Move the nodes with higher current requirements closer to the power supply.

If formula 1 or formula 2 is still not satisfied after making the changes listed above, the network's power cannot be supplied by a single power supply. Proceed to Step 3.

Example Configuration 1

In this example, the power supply is at one end of the trunk line. The trunk line is thick cable and the branch lines are thin cable.

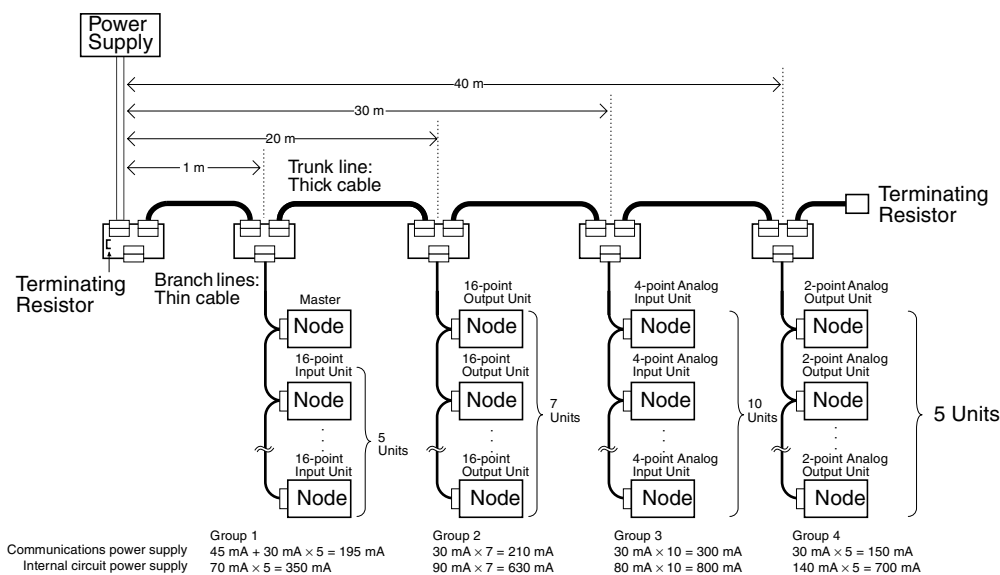

1. Calculate the voltage drop when the communications power supply provides communications power only (formula 1.)

Group 1: $(1 \times 0.015 + 1 \times 0.005) \times 0.195 = 0.0039 \text{ V}$
 Group 2: $(20 \times 0.015 + 2 \times 0.005) \times 0.21 = 0.0651 \text{ V}$

Group 3: $(30 \times 0.015 + 3 \times 0.005) \times 0.30 = 0.1395 \text{ V}$
 Group 4: $(40 \times 0.015 + 4 \times 0.005) \times 0.15 = 0.093 \text{ V}$
 Total voltage drop = $0.0039 + 0.0651 + 0.1395 + 0.093 = 0.3015 \text{ V} \leq 4.65 \text{ V}$
 In this case, formula 1 is satisfied, so the power supply can supply just the communications power.

2. Calculate the voltage drop when the communications power supply provides both communications power and internal circuit power (formula 2.)

Group 1: $(1 \times 0.015 + 1 \times 0.005) \times 0.545 = 0.0109 \text{ V}$
 Group 2: $(20 \times 0.015 + 2 \times 0.005) \times 0.84 = 0.2604 \text{ V}$
 Group 3: $(30 \times 0.015 + 3 \times 0.005) \times 1.1 = 0.5115 \text{ V}$
 Group 4: $(40 \times 0.015 + 4 \times 0.005) \times 0.85 = 0.527 \text{ V}$
 Total voltage drop = $0.0109 + 0.2604 + 0.5115 + 0.527 = 1.3098 \text{ V} \geq 0.65 \text{ V}$
 In this case, formula 2 is not satisfied, so the power supply cannot supply the communications power and internal circuit power.

Example Configuration 2

In this example, the power supply is near the middle of the trunk line. The trunk line is thick cable and the branch lines are thin cable.

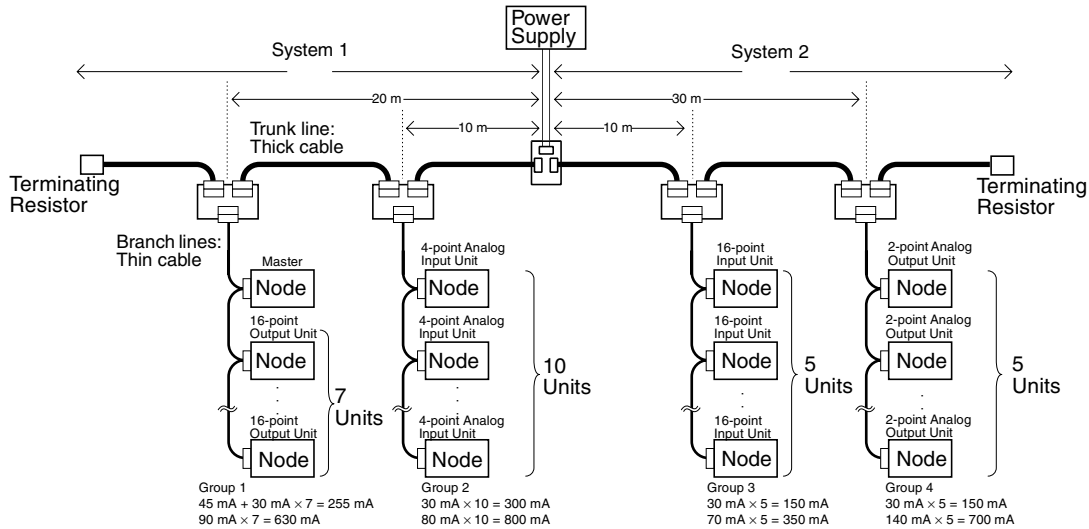

1. Calculate the voltage drop when the communications power supply provides communications power only (formula 1.)

- a) System 1 (Left Side)

Group 1: $(20 \times 0.015 + 2 \times 0.005) \times 0.255 = 0.0791 \text{ V}$
 Group 2: $(10 \times 0.015 + 1 \times 0.005) \times 0.3 = 0.0465 \text{ V}$
 Total voltage drop = $0.0791 + 0.0465 = 0.1256 \text{ V} \leq 4.65 \text{ V}$
 In this case, formula 1 is satisfied on the left side.

- b) System 2 (Right Side)

Group 3: $(10 \times 0.015 + 1 \times 0.005) \times 0.15 = 0.0233 \text{ V}$
 Group 4: $(30 \times 0.015 + 2 \times 0.005) \times 0.15 = 0.069 \text{ V}$
 Total voltage drop = $0.0233 + 0.069 = 0.0923 \text{ V} \leq 4.65 \text{ V}$
 In this case, formula 1 is satisfied on the right side.

2. Calculate the voltage drop when the communications power supply provides both communications power and internal circuit power (formula 2.)

- a) System 1 (Left Side)

$$\text{Group 1: } (20 \times 0.015 + 2 \times 0.005) \times 0.885 = 0.2744 \text{ V}$$

$$\text{Group 2: } (10 \times 0.015 + 1 \times 0.005) \times 1.1 = 0.1705 \text{ V}$$

$$\text{Total voltage drop} = 0.2744 + 0.1705 = 0.4449 \text{ V} \leq 0.65 \text{ V}$$

In this case, formula 2 is satisfied on the left side.

b) System 2 (Right Side)

$$\text{Group 3: } (10 \times 0.015 + 1 \times 0.005) \times 0.5 = 0.0775 \text{ V}$$

$$\text{Group 4: } (30 \times 0.015 + 2 \times 0.005) \times 0.85 = 0.391 \text{ V}$$

$$\text{Total voltage drop} = 0.0775 + 0.391 = 0.4685 \text{ V} \leq 0.65 \text{ V}$$

In this case, formula 2 is satisfied on the right side.

3-6 Step 3: Splitting the System into Multiple Power Supplies

If the calculations in step 2 indicate that a single power supply cannot provide power properly for the network, proceed with this step and install multiple power supplies to split up the power supply system.

3-6-1 Splitting the Power Supply System

- When there are two or more power supplies in the network, Power Supply Taps must be used to connect the power supplies.
- Remove a fuse in the Power Supply Tap to supply power to just one side and split the power supply system.

Once the power supply system is split, return to Step 1 or 2, and evaluate whether the separated power supply systems can supply power properly.

3-6-2 Configuration of the Power Supply Tap

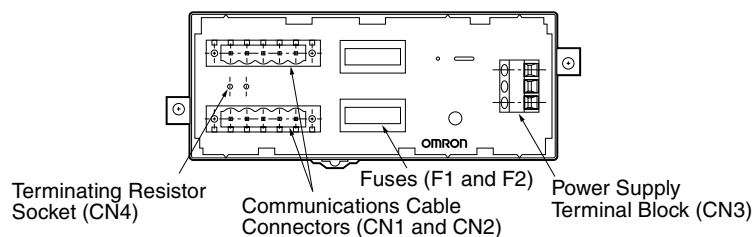

3-6-3 Internal Circuits in the Power Supply Tap

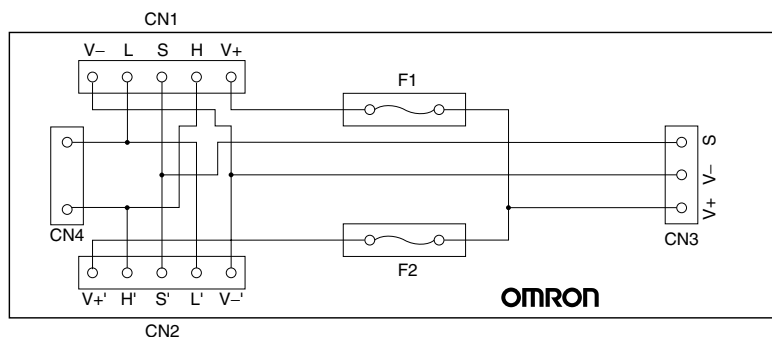

Pin	Name
V-	V-
L	CAN L
S	SHIELD
H	CAN H
V+	V+

Remove fuse F1 to cut off the power supply (V+) to CN1. Remove fuse F2 to cut off the power supply (V+) to CN2.

Appendix A

Connectable Device Lists

Master Units

Model	Specifications
CS1W-DRM21(-V1)	For CS-series PLCs
CJ1W-DRM21	For CJ-series PLCs
CVM1-DRM21-V1	For CVM1 and CV-series PLCs
C200HW-DRM21-V1	For CS-series, C200HX/HG/HE, and C200HS PLCs
3G8F7-DRM21	PCI Board
3G8B3-DRM21	VME Board

Configurator

Model	Specifications
WS02-CFDC1-E	Configurator Software Version 2.□
3G8E2-DRM21-V1	Configurator Software Version 2.□ (Included with the PCMCIA Card.)

Slave Units

DRT2-series General-purpose Slaves

Model	Specifications
DRT2-ID08	Remote I/O Terminal with 8 transistor inputs (NPN)
DRT2-ID08-1	Remote I/O Terminal with 8 transistor inputs (PNP)
DRT2-ID16	Remote I/O Terminal with 16 transistor inputs (NPN)
DRT2-ID16-1	Remote I/O Terminal with 16 transistor inputs (PNP)
DRT2-OD08	Remote I/O Terminal with 8 transistor outputs (NPN)
DRT2-OD08-1	Remote I/O Terminal with 8 transistor outputs (PNP)
DRT2-OD16	Remote I/O Terminal with 16 transistor outputs (NPN)
DRT2-OD16-1	Remote I/O Terminal with 16 transistor outputs (PNP)
DRT2-MD16	Remote I/O Terminal with 8 transistor inputs and 8 transistor outputs (NPN)
DRT2-MD16-1	Remote I/O Terminal with 8 transistor inputs and 8 transistor outputs (PNP)
DRT2-ROS16	Remote I/O Terminal with 16 relay outputs
XWT-ID16	Remote I/O Terminal Expansion Unit with 16 transistor inputs (NPN)
XWT-ID16-1	Remote I/O Terminal Expansion Unit with 16 transistor inputs (PNP)
XWT-OD16	Remote I/O Terminal Expansion Unit with 16 transistor outputs (NPN)
XWT-OD16-1	Remote I/O Terminal Expansion Unit with 16 transistor outputs (PNP)
XWT-ID08	Remote I/O Terminal Expansion Unit with 8 transistor inputs (NPN)
XWT-ID08-1	Remote I/O Terminal Expansion Unit with 8 transistor inputs (PNP)
XWT-OD08	Remote I/O Terminal Expansion Unit with 8 transistor outputs (NPN)
XWT-OD08-1	Remote I/O Terminal Expansion Unit with 8 transistor outputs (PNP)
DRT2-ID16TA	Remote I/O Terminal with 3-tier terminal blocks and 16 transistor inputs (NPN)
DRT2-ID16TA-1	Remote I/O Terminal with 3-tier terminal blocks and 16 transistor inputs (PNP)
DRT2-OD16TA	Remote I/O Terminal with 3-tier terminal blocks and 16 transistor outputs (NPN)
DRT2-OD16TA-1	Remote I/O Terminal with 3-tier terminal blocks and 16 transistor outputs (PNP)
DRT2-MD16TA	Remote I/O Terminal with 3-tier terminal blocks and 8 transistor inputs/8 transistor outputs (NPN)
DRT2-MD16TA-1	Remote I/O Terminal with 3-tier terminal blocks and 8 transistor inputs/8 transistor outputs (PNP)
DRT2-ID16S	Sensor Connector Terminal with 16-point Transistor Input (NPN)
DRT2-ID16S-1	Sensor Connector Terminal with 16-point Transistor Input (PNP)
DRT2-MD16S	Sensor Connector Terminal with 8 transistor inputs and 8 transistor outputs (NPN)
DRT2-MD16S-1	Sensor Connector Terminal with 8 transistor inputs and 8 transistor outputs (PNP)
DRT2-ID16ML	MIL Connector Terminal with 16 transistor inputs (NPN)
DRT2-ID16ML-1	MIL Connector Terminal with 16 transistor inputs (PNP)
DRT2-ID16MLX	MIL Connector Terminal with 16 transistor inputs (NPN), cable with connectors included
DRT2-ID16MLX-1	MIL Connector Terminal with 16 transistor inputs (PNP), cable with connectors included
DRT2-ID32ML	MIL Connector Terminal with 32 transistor inputs (NPN)
DRT2-ID32ML-1	MIL Connector Terminal with 32 transistor inputs (PNP)
DRT2-OD16ML	MIL Connector Terminal with 16 transistor outputs (NPN)
DRT2-OD16ML-1	MIL Connector Terminal with 16 transistor outputs (PNP)
DRT2-OD16MLX	MIL Connector Terminal with 16 transistor outputs (NPN), cable with connectors included
DRT2-OD16MLX-1	MIL Connector Terminal with 16 transistor outputs (PNP), cable with connectors included
DRT2-OD32ML	MIL Connector Terminal with 32 transistor outputs (NPN)
DRT2-OD32ML-1	MIL Connector Terminal with 32 transistor outputs (PNP)
DRT2-MD32ML	MIL Connector Terminal with 16 transistor inputs/16 transistor outputs (NPN)
DRT2-MD32ML-1	MIL Connector Terminal with 16 transistor inputs/16 transistor outputs (PNP)
DRT2-ID32B	Board MIL Connector Terminal with connector parallel to board and with 32 transistor inputs (NPN)
DRT2-ID32B-1	Board MIL Connector Terminal with connector parallel to board and with 32 transistor inputs (PNP)

Model	Specifications
DRT2-OD32B	Board MIL Connector Terminal with connector parallel to board and with 32 transistor outputs (NPN)
DRT2-OD32B-1	Board MIL Connector Terminal with connector parallel to board and with 32 transistor outputs (PNP)
DRT2-MD32B	Board MIL Connector Terminal with connector parallel to board and with 16 transistor inputs/16 transistor outputs (NPN)
DRT2-MD32B-1	Board MIL Connector Terminal with connector parallel to board and with 16 transistor inputs/16 transistor outputs (PNP)
DRT2-ID32BV	Board MIL Connector Terminal with connector perpendicular to board and with 32 transistor inputs (NPN)
DRT2-ID32BV-1	Board MIL Connector Terminal with connector perpendicular to board and with 32 transistor inputs (PNP)
DRT2-OD32BV	Board MIL Connector Terminal with connector perpendicular to board and with 32 transistor outputs (NPN)
DRT2-OD32BV-1	Board MIL Connector Terminal with connector perpendicular to board and with 32 transistor outputs (PNP)
DRT2-MD32BV	Board MIL Connector Terminal with connector perpendicular to board and with 16 transistor inputs/16 transistor outputs (NPN)
DRT2-MD32BV-1	Board MIL Connector Terminal with connector perpendicular to board and with 16 transistor inputs/16 transistor outputs (PNP)
DRT2-ID16SL	Screw-less Clamp Terminal with 16 transistor inputs and no detection functions (NPN)
DRT2-ID16SL-1	Screw-less Clamp Terminal with 16 transistor inputs and no detection functions (PNP)
DRT2-OD16SL	Screw-less Clamp Terminal with 16 transistor outputs and no detection functions (NPN)
DRT2-OD16SL-1	Screw-less Clamp Terminal with 16 transistor outputs and no detection functions (PNP)
DRT2-ID16SLH	Screw-less Clamp Terminal with 16 transistor inputs and detection functions (NPN)
DRT2-ID16SLH-1	Screw-less Clamp Terminal with 16 transistor inputs and detection functions (PNP)
DRT2-OD16SLH	Screw-less Clamp Terminal with 16 transistor outputs and detection functions (NPN)
DRT2-OD16SLH-1	Screw-less Clamp Terminal with 16 transistor outputs and detection functions (PNP)
DRT2-ID32SL	Screw-less Clamp Terminal with 32 transistor inputs and no detection functions (NPN)
DRT2-ID32SL-1	Screw-less Clamp Terminal with 32 transistor inputs and no detection functions (PNP)
DRT2-OD32SL	Screw-less Clamp Terminal with 32 transistor outputs and no detection functions (NPN)
DRT2-OD32SL-1	Screw-less Clamp Terminal with 32 transistor outputs and no detection functions (PNP)
DRT2-MD32SL	Screw-less Clamp Terminal with 16 transistor inputs, 16 transistor outputs, and no detection functions (NPN)
DRT2-MD32SL-1	Screw-less Clamp Terminal with 16 transistor inputs, 16 transistor outputs, and no detection functions (PNP)
DRT2-ID32SLH	Screw-less Clamp Terminal with 32 transistor inputs and detection functions (NPN)
DRT2-ID32SLH-1	Screw-less Clamp Terminal with 32 transistor inputs and detection functions (PNP)
DRT2-OD32SLH	Screw-less Clamp Terminal with 32 transistor outputs and detection functions (NPN)
DRT2-OD32SLH-1	Screw-less Clamp Terminal with 32 transistor outputs and detection functions (PNP)
DRT2-MD32SLH	Screw-less Clamp Terminal with 16 transistor inputs, 16 transistor outputs, and detection functions (NPN)
DRT2-MD32SLH-1	Screw-less Clamp Terminal with 16 transistor inputs, 16 transistor outputs, and detection functions (PNP)

DRT1-series General-purpose Slaves

Model	Specifications
DRT1-ID08	I/O Terminal with 8 transistor inputs (NPN)
DRT1-ID08-1	I/O Terminal with 8 transistor inputs (PNP)
DRT1-ID16	I/O Terminal with 16 transistor inputs (NPN)
DRT1-ID16-1	I/O Terminal with 16 transistor inputs (PNP)
DRT1-OD08	I/O Terminal with 8 transistor outputs (NPN)
DRT1-OD08-1	I/O Terminal with 8 transistor outputs (PNP)
DRT1-OD16	I/O Terminal with 16 transistor outputs (NPN)
DRT1-OD16-1	I/O Terminal with 16 transistor outputs (PNP)
DRT1-MD16	I/O Terminal with 8 transistor inputs and 8 transistor outputs (NPN)
DRT1-ID16T	I/O Terminal with 16 transistor inputs (NPN), Three-tier Terminal Block type
DRT1-ID16T-1	I/O Terminal with 16 transistor inputs (PNP), Three-tier Terminal Block type
DRT1-OD16T	I/O Terminal with 16 transistor outputs (NPN), Three-tier Terminal Block type
DRT1-OD16T-1	I/O Terminal with 16 transistor outputs (PNP), Three-tier Terminal Block type
DRT1-MD16T	I/O Terminal with 8 transistor inputs and 8 transistor outputs (NPN), Three-tier Terminal Block type
DRT1-MD16T-1	I/O Terminal with 8 transistor inputs and 8 transistor outputs (PNP), Three-tier Terminal Block type
DRT1-ID16TA	I/O Terminal with 16 transistor inputs (NPN), Three-tier Terminal Block type (Internal power supply not required.)
DRT1-ID16TA-1	I/O Terminal with 16 transistor inputs (PNP), Three-tier Terminal Block type (Internal power supply not required.)
DRT1-OD16TA	I/O Terminal with 16 transistor outputs (NPN), Three-tier Terminal Block type (Internal power supply not required.)
DRT1-OD16TA-1	I/O Terminal with 16 transistor outputs (PNP), Three-tier Terminal Block type (Internal power supply not required.)
DRT1-MD16TA	I/O Terminal with 8 transistor inputs and 8 transistor outputs (NPN), Three-tier Terminal Block type (Internal power supply not required.)
DRT1-MD16TA-1	I/O Terminal with 8 transistor inputs and 8 transistor outputs (PNP), Three-tier Terminal Block type (Internal power supply not required.)
DRT1-ID32ML	I/O Terminal with 32 transistor inputs (NPN) with connector (Internal power supply not required.)
DRT1-ID32ML-1	I/O Terminal with 32 transistor inputs (PNP) with connector (Internal power supply not required.)
DRT1-OD32ML	I/O Terminal with 32 transistor outputs (NPN) with connector (Internal power supply not required.)
DRT1-OD32ML-1	I/O Terminal with 32 transistor outputs (PNP) with connector (Internal power supply not required.)
DRT1-MD32ML	I/O Terminal with 16 transistor outputs and 16 transistor outputs (NPN) with connector (Internal power supply not required.)
DRT1-MD32ML-1	I/O Terminal with 16 transistor outputs and 16 transistor outputs (PNP) with connector (Internal power supply not required.)
DRT1-ID16X	Remote Adapter with 16 transistor inputs (NPN)
DRT1-ID16X-1	Remote Adapter with 16 transistor inputs (PNP)
DRT1-OD16X	Remote Adapter with 16 transistor outputs (NPN)
DRT1-OD16X-1	Remote Adapter with 16 transistor outputs (PNP)
DRT1-HD16S	Sensor Terminal with 8 sensor inputs (NPN), 2 inputs per sensor
DRT1-ND16S	Sensor Terminal with 8 sensor inputs/outputs (NPN), 1 input and 1 output per sensor
CQM1-DRT21	I/O Link Unit for CQM1 PLCs with 16 inputs and 16 outputs
CPM1A-DRT21	I/O Link Unit for CPM1A/CPM2A PLCs with 32 inputs and 32 outputs

DRT2-series Environment-resistive Slaves

Model	Specifications
DRT2-ID08C	Environment-resistive Terminal with 8 transistor inputs (NPN), meets IEC IP67 standards
DRT2-ID08C-1	Environment-resistive Terminal with 8 transistor inputs (PNP), meets IEC IP67 standards
DRT2-HD16C	Environment-resistive Terminal with 16 transistor inputs (NPN), meets IEC IP67 standards
DRT2-HD16C-1	Environment-resistive Terminal with 16 transistor inputs (PNP), meets IEC IP67 standards
DRT2-OD08C	Environment-resistive Terminal with 8 transistor outputs (NPN), meets IEC IP67 standards
DRT2-OD08C-1	Environment-resistive Terminal with 8 transistor outputs (PNP), meets IEC IP67 standards
DRT2-ID04CL	Standard Environment-resistive Terminal with 4 transistor inputs (NPN) Conforms to IEC IP67
DRT2-ID04CL-1	Standard Environment-resistive Terminal with 4 transistor inputs (PNP) Conforms to IEC IP67
DRT2-ID08CL	Standard Environment-resistive Terminal with 8 transistor inputs (NPN) Conforms to IEC IP67
DRT2-ID08CL-1	Standard Environment-resistive Terminal with 8 transistor inputs (PNP) Conforms to IEC IP67
DRT2-HD16CL	Standard Environment-resistive Terminal with 16 transistor inputs (NPN) Conforms to IEC IP67
DRT2-HD16CL-1	Standard Environment-resistive Terminal with 16 transistor inputs (PNP) Conforms to IEC IP67
DRT2-OD04CL	Standard Environment-resistive Terminal with 4 transistor outputs (NPN) Conforms to IEC IP67
DRT2-OD04CL-1	Standard Environment-resistive Terminal with 4 transistor outputs (PNP) Conforms to IEC IP67
DRT2-OD08CL	Standard Environment-resistive Terminal with 8 transistor outputs (NPN) Conforms to IEC IP67
DRT2-OD08CL-1	Standard Environment-resistive Terminal with 8 transistor outputs (PNP) Conforms to IEC IP67
DRT2-WD16CL	Standard Environment-resistive Terminal with 16 transistor outputs (NPN) Conforms to IEC IP67
DRT2-WD16CL-1	Standard Environment-resistive Terminal with 16 transistor outputs (PNP) Conforms to IEC IP67
DRT2-MD16CL	Standard Environment-resistive Terminal with 8 transistor inputs /8 transistor outputs (NPN) Conforms to IEC IP67
DRT2-MD16CL-1	Standard Environment-resistive Terminal with 8 transistor inputs /8 transistor outputs (PNP) Conforms to IEC IP67

DRT1-series Environment-resistive Slaves

Model	Specifications
DRT1-ID08C	Environment-resistive Terminal with 8 transistor inputs (NPN), meets IEC IP66 standards
DRT1-HD16C	Environment-resistive Terminal with 16 transistor inputs (NPN), meets IEC IP66 standards
DRT1-HD16C-1	Environment-resistive Terminal with 16 transistor inputs (PNP), meets IEC IP66 standards
DRT1-OD08C	Environment-resistive Terminal with 8 transistor outputs (NPN), meets IEC IP66 standards
DRT1-WD16C	Environment-resistive Terminal with 16 transistor outputs (NPN), meets IEC IP66 standards
DRT1-WD16C-1	Environment-resistive Terminal with 16 transistor outputs (PNP), meets IEC IP66 standards
DRT1-MD16C	Environment-resistive Terminal with 8 transistor inputs and 8 transistor outputs (NPN), meets IEC IP66 standards
DRT1-MD16C-1	Environment-resistive Terminal with 8 transistor inputs and 8 transistor outputs (PNP), meets IEC IP66 standards
DRT1-ID04CL	Waterproof Terminal with 4 transistor inputs (NPN), meets IEC IP67 standards
DRT1-ID04CL-1	Waterproof Terminal with 4 transistor inputs (PNP), meets IEC IP67 standards
DRT1-ID08CL	Waterproof Terminal with 8 transistor inputs (NPN), meets IEC IP67 standards
DRT1-ID08CL-1	Waterproof Terminal with 8 transistor inputs (PNP), meets IEC IP67 standards
DRT1-OD04CL	Waterproof Terminal with 4 transistor outputs (NPN), meets IEC IP67 standards
DRT1-OD04CL-1	Waterproof Terminal with 4 transistor outputs (PNP), meets IEC IP67 standards
DRT1-OD08CL	Waterproof Terminal with 8 transistor outputs (NPN), meets IEC IP67 standards
DRT1-OD08CL-1	Waterproof Terminal with 8 transistor outputs (PNP), meets IEC IP67 standards
DRT1-B7AC	B7AC Interface Terminal with 10 inputs × 3, meets IEC IP66 standards

DRT2-series Analog Slaves

Model	Specifications
DRT2-AD04	Analog Input Terminal with 4 analog data inputs (4 words)
DRT2-AD04H	High-resolution Analog Input Terminal with 4 analog data inputs (4 words)
DRT2-DA02	Analog Output Terminal with 2 analog data inputs (2 words)
DRT2-TS04T	Thermocouple Temperature Input Terminal with 4 temperature data inputs
DRT2-TS04P	Platinum-resistance Thermometer Temperature Input Terminal with 4 temperature data inputs

DRT1-series Special I/O Slave Units

Model	Specifications
CPM2C-S100C-DRT	Programmable Slaves
CPM2C-S110C-DRT	These Slaves are equipped with SYSMAC CPM2C functions and CompoBus/S Master functions. Explicit messaging can be used to read/write data in any data area.
C200HW-DRT21	I/O Link Unit for C200HX/HG/HE PLCs 512 inputs max., 512 outputs max. (Linked areas can be user-set.) Explicit messaging can be used to read/write data in any data area.
DRT1-232C2	RS-232C Unit with 2 RS-232C ports 16 inputs (communications status) Explicit messaging can be used to set the RS-232C ports' parameters and transfer data to/from external devices.

MULTIPLE I/O TERMINAL Units

Model	Specifications
DRT1-COM	Communications Unit, two input words (status)
GT1-ID16	Transistor Input Unit (terminal block) with 16 transistor inputs (NPN)
GT1-ID16-1	Transistor Input Unit (terminal block) with 16 transistor inputs (PNP)
GT1-ID16MX	Transistor Input Unit (MOLEX connector) with 16 transistor inputs (NPN)
GT1-ID16MX-1	Transistor Input Unit (MOLEX connector) with 16 transistor inputs (PNP)
GT1-ID16ML	Transistor Input Unit (FUJITSU connector) with 16 transistor inputs (NPN)
GT1-ID16ML-1	Transistor Input Unit (FUJITSU connector) with 16 transistor inputs (PNP)
GT1-ID16DS	Transistor Input Unit (D-sub, 25-pin connector) with 16 transistor inputs (NPN)
GT1-ID16DS-1	Transistor Input Unit (D-sub, 25-pin connector) with 16 transistor inputs (PNP)
GT1-ID32ML	Transistor Input Unit (FUJITSU high-density connector) with 32 transistor inputs (NPN)
GT1-ID32ML-1	Transistor Input Unit (FUJITSU high-density connector) with 32 transistor inputs (PNP)
GT1-OD16	Transistor Output Unit (terminal block) with 16 transistor outputs (NPN)
GT1-OD16-1	Transistor Output Unit (terminal block) with 16 transistor outputs (PNP)
GT1-OD16MX	Transistor Output Unit (MOLEX connector) with 16 transistor outputs (NPN)
GT1-OD16MX-1	Transistor Output Unit (MOLEX connector) with 16 transistor outputs (PNP)
GT1-OD16ML	Transistor Output Unit (FUJITSU connector) with 16 transistor outputs (NPN)
GT1-OD16ML-1	Transistor Output Unit (FUJITSU connector) with 16 transistor outputs (PNP)
GT1-OD16DS	Transistor Output Unit (D-sub, 25-pin connector) with 16 transistor outputs (NPN)
GT1-OD16DS-1	Transistor Output Unit (D-sub, 25-pin connector) with 16 transistor outputs (PNP)
GT1-OD32ML	Transistor Output Unit (FUJITSU high-density connector) with 32 transistor outputs (NPN)
GT1-OD32ML-1	Transistor Output Unit (FUJITSU high-density connector) with 32 transistor outputs (PNP)
GT1-ROP08	Relay Output Unit (power relays) with 8 relay outputs (allocated 1 word)
GT1-ROS16	Relay Output Unit (miniature relays) with 16 relay outputs
GT1-AD04	Analog Input Unit (terminal block) with 4 inputs (allocated 4 words)
GT1-AD08MX	Analog Input Unit (MOLEX connector) with 8 inputs (allocated 4 words) or 4 inputs (allocated 4 words) (Use the DIP switch to select 8 inputs or 4 inputs.)
GT1-DA04	Analog Output Unit (terminal block) with 4 outputs (allocated 4 words)
GT1-DA04MX	Analog Output Unit (MOLEX connector) with 4 outputs (allocated 4 words)
GT1-TS04T	Temperature Input Unit with 4 temperature inputs (Thermocouple: R, S, K, J, T, B, or L) (Use the DIP switch to allocate 4 words or 8 words.)
GT1-TS04P	Temperature Input Unit with 4 temperature inputs (Platinum-resistance thermometer: Pt100 or JPt100) (Use the DIP switch to allocate 4 words or 8 words.)
GT1-CT01	Counter Unit with 1 encoder input (A, B, Z), 1 external input, and 2 external outputs (allocated 3 input words and 3 output words)

Communications Cables

Model	Specifications
DCA2-5C10	Thick cable: 5 wires, 100 m
DCA1-5C10	Thin cable: 5 wires, 100 m
DCA1-5CN□□W1	Cable with shielded micro-size (M12) connectors on both ends (female socket and male plug)
DCA1-5CN□□F1	Cable with shielded micro-size (M12) connector (female socket) on one end
DCA1-5CN□□H1	Cable with shielded micro-size (M12) connector (male plug) on one end
DCA1-5CN□□W5	Cable with shielded connector on both ends (male plug on mini-size end, female socket on micro-size end)
DCA2-5CN□□W1	Cable with shielded mini-size connectors on both ends (female socket and male plug)
DCA2-5CN□□F1	Cable with shielded mini-size connector on one end (female socket)
DCA2-5CN□□H1	Cable with shielded mini-size connector on one end (male plug)
DCA4-4F10	Flat cable (4-wire flat cable without sheath, conforming to UL standards), size: 100 m, conductor diameter: $0.75 \text{ mm}^2 \times 2 \text{ wires}$, $0.5 \text{ mm}^2 \times 2 \text{ wires}$

A variety of DeviceNet communications cables are available from several manufacturers. For details, refer to the home page of the ODVA at the following URL:

<http://www.odva.org/>

Connectors

Model	Specifications	Remarks
XW4B-05C1-H1-D	Straight connector with attachment screws for node or T-branch Tap connections	With connector attachment screws
MSTB2.5/5-ST-5.08AU	Straight connector without attachment screws for node connections	Without connector attachment screws PHOENIX CONTACT model number 1752399
XW4B-05C1-VIR-D	Right-angle connector with attachment screws for node or T-branch Tap connections	With connector attachment screws
XW4G-05C1-H1-D	Straight clamp connector with attachment screws for node or T-branch Tap connections	With connector attachment screws
XW4B-05C4-TF-D	Right-angle multi-drop connector with attachment screws for node or T-branch Tap connections	With connector attachment screws
XW4B-05C4-T-D	Right-angle multi-drop connector without attachment screws for node or T-branch Tap connections	Without connector attachment screws
XW4G-05C4-TF-D	Straight multi-drop clamp connector with attachment screws for node or T-branch Tap connections	With connector attachment screws
DCN4-SF4D	Flat cable connector with attachment screws, for connecting nodes	With connector attachment screws
DCA1-5CN□□W1	Thin cable with shielded, micro-size (M12) connectors on both ends for Environment-resistive Slave or shielded T-branch Connector (micro-size) connections	Available cable lengths: 0.5 m, 1 m, 2 m, 3 m, 5 m, and 10 m
DCA1-5CN□□F1	Thin cable with shielded, micro-size (M12) female connector on one end for Environment-resistive Slave or shielded T-branch Connector (micro-size) connections	Available cable lengths: 0.5 m, 1 m, 2 m, 3 m, 5 m, and 10 m
DCA1-5CN□□H1	Thin cable with shielded, micro-size (M12) male connector on one end for shielded T-branch Connector (micro-size) connections	Available cable lengths: 0.5 m, 1 m, 2 m, 3 m, 5 m, and 10 m
DCA2-5CN□□W5	Thin cable with shielded mini-size male connector on one end and shielded micro-size (M12) female connector on the other end for Environment-resistive Slave or shielded T-branch Connector connections	Available cable lengths: 1 m, 2 m, 5 m, and 10 m
DCA2-5CN□□W1	Thick cable with shielded, mini-size connectors on both ends for Environment-resistive Slave or shielded T-branch Connector (mini-size) connections	Available cable lengths: 1 m, 2 m, 5 m, and 10 m
DCA2-5CN□□F1	Thick cable with shielded, mini-size female connector on one end for Environment-resistive Slave or shielded T-branch Connector (mini-size) connections	Available cable lengths: 1 m, 2 m, 5 m, and 10 m
DCA2-5CN□□H1	Thick cable with shielded, mini-size male connector on one end for Environment-resistive Slave or shielded T-branch Connector (mini-size) connections	Available cable lengths: 1 m, 2 m, 5 m, and 10 m
XS2G-D5S7	Shielded, micro-size (M12) female connector for custom cable assembly (for Environment-resistive Slave or shielded T-branch Connector (micro-size) connections)	---
XS2C-D5S7	Shielded, micro-size (M12) male connector for custom cable assembly (for shielded T-branch Connector (micro-size) connections)	---

Crimp Terminals for Communications Cables

Model	Crimping tool	Specifications	Remarks
AI Series AI 0.25-6YE: For thin cable signal lines AI 0.5-6WH: For thin cable power lines AI 0.25-8YE: For thin cable signal lines AI 0.5-10WH: For thin cable power lines A1-6: For thick cable signal lines AI 2.5-8BU: For thick cable power lines A1-10: For thick cable signal lines AI 2.5-10BU: For thick cable power lines	CRIMPFOX ZA3	For a single wire	PHOENIX CONTACT
AI Series AI TWIN2 × 0.5-8WH (for thin cable)	CRIMPFOX UD6 or CRIMP-FOX ZA3	For two wires (multi-drop)	
H0.5/16.5 ZH		For two wires (multi-drop)	Weidmuller

Screwdrivers for Connector Set Screws

Model	Specifications	Manufacturer
XW4Z-00C	Screw driver for DeviceNet connectors	OMRON
SZF-1	Screw driver for DeviceNet connectors	PHOENIX CONTACT

Terminating Resistors

Model	Specifications
DRS1-T	Terminal-block Terminating Resistor (121 Ω \pm 1%, 1/4 W)
DRS2-1	Shielded Micro-size (M12) Connector with Terminating Resistance (male plug)
DRS2-2	Shielded Micro-size (M12) Connector with Terminating Resistance (female socket)
DRS3-1	Shielded Mini-size Connector with Terminating Resistance (male plug)
DCN4-TM4	Connector-type Terminating Resistor for Flat Cable, 121 Ω
DCN4-TP4D	Flat Cable Power Supply Terminal Block with Terminating Resistance (for Flat Cable), 121 Ω

In addition to the Terminating Resistors listed above, the trunk line can be terminated by installing a Terminating Resistor (included with the Tap) into the socket of a T-branch Tap or Power Supply Tap.

T-branch Taps

Single-branch Taps

Model	Specifications
DCN1-1NC	Three Straight Clamp Connectors with attachment screws (model XW4G-05C1-H1-D) are included with the DCN1-1NC. (The DCN1-1NC can make one branch.) The connector insertion direction is vertical. A Terminating Resistor (included) can be connected.
DCN1-1C	Three Straight Connectors with attachment screws (model XW4B-05C1-H1-D) are included with the DCN1-1C. (The DCN1-1C can make one branch.) The connector insertion direction is horizontal. A Terminating Resistor (included) can be connected.
DCN1-2C	Three Straight Connectors with attachment screws (model XW4B-05C1-H1-D) are included with the DCN1-2C. (The DCN1-2C can make one branch.) The connector insertion direction is vertical. A Terminating Resistor (included) can be connected.
DCN1-2R	Three Right-angle Connectors with attachment screws (model XW4B-05C1-VIR-D) are included with the DCN1-2R. (The DCN1-2R can make one branch.) The connector insertion direction is vertical. A Terminating Resistor (included) can be connected.

Three-branch Taps

Model	Specifications
DCN1-3NC	Five straight clamp connectors with attachment screws (model XW4G-05C1-H1-D) are included with the DCN1-3NC. (The DCN1-3NC can make three branches.) The connector insertion direction is vertical. A Terminating Resistor (included) can be connected.
DCN1-3C	Five straight connectors with attachment screws (model XW4B-05C1-H1-D) are included with the DCN1-3C. (The DCN1-3C can make three branches.) The connector insertion direction is horizontal. A Terminating Resistor (included) can be connected.
DCN1-4C	Five straight connectors with attachment screws (model XW4B-05C1-H1-D) are included with the DCN1-4C. (The DCN1-4C can make three branches.) The connector insertion direction is vertical. A Terminating Resistor (included) can be connected.
DCN1-4R	Five right-angle connectors with attachment screws (model XW4B-05C1-VIR-D) are included with the DCN1-4R. (The DCN1-4R can make three branches.) The connector insertion direction is vertical. A Terminating Resistor (included) can be connected.

Shielded T-branch Connectors

Model	Specifications
DCN2-1	Shielded T-branch Connector (1 branch) with 3 micro-size (M12) connectors
DCN3-11	Shielded T-branch Connector (1 branch) with 3 mini-size connectors
DCN3-12	Shielded T-branch Connector (1 branch) with 2 mini-size connectors and 1 micro-size (M12) connector

Flat Cable Connectors

Model	Specifications
DCN4-TR4-1	Flat connector socket for flat cable
DCN4-BR4	Flat connector plug for flat cable
DCN4-BR4D	Thin Cable-Flat Cable conversion connector. Used to branch to thin cable.

Power Supply Tap

Model	Specifications
DCN1-1P	The DCN1-1P is used to connect the communications power supply to the network. Includes two XW4B-05C1-H1-D Straight Connectors with attachment screws, a terminator, and two fuses. A Terminating Resistor (included) can be connected.

Cable Connectors for Sensor Terminals

Model	Specifications
XS8A-0441	Connector marking: XS8-1 Applicable cable wire size: 0.3 to 0.5 mm ²
XS8A-0442	Connector marking: XS8-2 Applicable cable wire size: 0.14 to 0.2 mm ²

Cable Connectors for Environment-resistive Slaves

The following cable connectors for Environment-resistive Slaves cannot be used for DeviceNet communications because of differences such as the number of pins that are used.

For DRT1-□D□□C(-1) Slaves

Connector type	Model	Specifications
I/O connectors	XS2G-D4□□	Shielded, micro-size (M12) male plug connector for custom cable assembly (crimp or solder)
	XS2H-D421-□□□	Cable with shielded, micro-size (M12) male plug connector on one end and loose wires on the other
	XS2W-D42□-□□□	Cable with shielded, micro-size (M12) connectors on both ends (male plug on one end and female socket on the other)
External power supply connectors	XS2C-D4□□	Shielded, micro-size (M12) female socket connector for custom cable assembly (crimp or solder)
	XS2F-D42□-□80-A	Cable with shielded, micro-size (M12) female socket connector on one end and loose wires on the other

For DRT1-□D□□CL(-1) Slaves

Connector type	Model	Specifications
I/O connectors	XS2G-D4□□	Shielded, micro-size (M12) male plug connector for custom cable assembly (crimp or solder)
	XS2H-D421-□□□□-□	Cable with shielded, micro-size (M12) male plug connector on one end and loose wires on the other
	XS2W-D42□-□□□□-□	Cable with shielded, micro-size (M12) connectors on both ends (male plug on one end and female socket on the other)
External power supply connectors	XS2C-D4□□	Shielded, micro-size (M12) female socket connector for custom cable assembly (crimp or solder)
	XS2F-D42□-□80-□	Cable with shielded, micro-size (M12) female socket connector on one end and loose wires on the other
	XS2W-D42□-□□□□-□	Cable with shielded, micro-size (M12) connectors on both ends (female socket on one end and male plug on the other)

For DRT1-B7AC Slaves

Connector type	Model	Specifications
I/O connectors	XS2G-D4□□	Shielded, micro-size (M12) male plug connector for custom cable assembly (crimp or solder)
	XS2H-D42□-□□□□-□	Cable with shielded, micro-size (M12) male plug connector on one end and loose wires on the other
	XS2W-D42□-□□□□-□	Cable with shielded, micro-size (M12) connectors on both ends (male plug on one end and female socket on the other)
External power supply connectors	XS2C-D4□□	Shielded, micro-size (M12) female socket connector for custom cable assembly (crimp or solder)
	XS2F-D42□-□□□□-□	Cable with shielded, micro-size (M12) female socket connector on one end and loose wires on the other
	XS2W-D42□-□□□□-□	Cable with shielded, micro-size (M12) connectors on both ends (female socket on one end and male plug on the other)

T Joint

Model	Specifications
XS2R-D427-5	Use the Shielded T-branch Joint to branch a cable for the Environment-resistive Slave's internal power supply.

Y Joint

Model	Specifications	
XS2R-D426-□11F	With cable	Use with 16-input or 16-output Environment-resistive Terminals. (Branches one connector's signals to two connectors.)
XS2R-D426-1	Without cable	

Connectors for Environment-resistive Slaves

Model	Specifications
XS2Z-12	Waterproof Cover (Meets IP67 enclosure rating.)
XS2Z-15	Dust cover

RS-232C Connectors for RS-232C Units

	Model	Specifications	Remarks
Plug	XS2D-0901 or equivalent	9-pin, female	OMRON
Hood	XM2S-0913 or equivalent	9-pin, inch pitch	
Recommended cable	UL2464 AWG28×5P IFS-RVV-SB	UL listed	Fujikura Ltd.
	AWG28×5P IFVV-SB	Not UL listed	
	UL2464-SB 5P×AWG28	UL listed	Hitachi Cable, Ltd.
	CO-MA-VV-SB 5P×AWG28	Not UL listed	

Mounting Bracket for Connector-type I/O Terminals

Model	Specifications
SRT2-ATT02	Mounting Bracket B

Connector Pressure-welding Pliers for Flat Cable

Model	Specifications
DWT-A01	Pressure-welding Pliers

MIL Specification Cable for Connector-type I/O Terminals

Model	Compatible Slaves	Compatible Relay Terminals
G79-I50-25-D1 (50 cm) G79-I75-50-D1 (75 cm)	DRT1-ID32ML DRT1-OD32ML-1	G7TC-ID16, G7TC-IA16 G7TC-OC16-4, M7F
G79-I50-25-D2 (50 cm) G79-I75-50-D2 (75 cm)	DRT1-ID32ML-1	G70A-ZIM16-5
G79-O50-25-D1 (50 cm) G79-O75-50-D1 (75 cm)	DRT1-OD32ML DRT1-OD32ML-1	G7TC-OC08/OC16, G70D-SOC16/VSOC16, G70A-ZOC16-3 G70A-ZOC16-4, G70D-SOC16-1
G79-M50-25-D1 (50 cm) G79-M75-50-D1 (75 cm)	DRT1-MD32ML	Input: G7TC-ID16/IA16 Output: G7TC-OC08/OC16, G70D-SOC16/VSOC16, G70A-ZOC16-3
G79-M50-25-D2 (50 cm) G79-M75-50-D2 (75 cm)	DRT1-MD32ML-1	Input: G70A-ZIM16-5 Output: G70A-ZOC16-4, G70D-SOC16-1

Cables with 40-pin Connector on One End

Model	Specifications
G79-A200C-D1 (2 m) G79-A500C-D1 (5 m)	40-pin connector on one end, plain wires (28 AWG) on the other end
G79-Y100C-D1 (1 m) G79-Y200C-D1 (2 m) G79-Y500C-D1 (5 m)	40-pin connector on one end, wires (28 AWG) with fork terminals attached on the other end Fork terminal model: 161071-M2

Connector for Flat Ribbon Cable

Model	Specifications
XG4M-4030-T	Compatible cable wire gauge: 28 AWG

Loose Wire Crimp Connectors

Item	Model	Specifications
Socket	XG5M-4032-N	Compatible cable wire gauge: 24 AWG
	XG5M-4035-N	Compatible cable wire gauge: 28 to 26 AWG
Partial Cover	XG5S-2001	Two required per connector.
Hood Cover	XG5S-5022	Cannot be used with multi-drop DeviceNet connectors.

I/O Connecting Cables for MULTIPLE I/O TERMINAL Units

Model	Specifications
(Provided with I/O Units)	Cable length: 40 mm
(Provided with Communications Units)	End connector
GCN1-010	Cable length: 0.1 m
GCN1-030	Cable length: 0.3 m
GCN1-040	Cable length: 0.4 m
GCN1-060	Cable length: 0.6 m
GCN1-100	Cable length: 1 m

Connectors for MULTIPLE I/O TERMINAL Units

Model	Description			Remarks
14-60-0032	MOLEX connectors	Pressure weld connection	Housing	For 24 AWG
50-57-9403		Crimp connection	Housing	
16-02-0069			Reeled pins	For 24 to 30 AWG
16-02-0086				For 22 to 24 AWG
16-02-0096			Loose pins	For 24 to 30 AWG
16-02-0102				For 22 to 24 AWG
11-01-0209			Crimping Tool	For 24 to 30 AWG

Connector Cables for MULTIPLE I/O TERMINAL Units

Model	Unit connected
G79-□□□C	Connects a GT1-ID16ML to an I/O Block (G7TC-I□16).
	Connects a GT1-OD16ML to an I/O Block (G7TC-OC16, G7OD-SOC16, G7OD-FOM16, G7OA-ZOC16-3, or M7F).
	Connects a GT1-OD16ML-1 to an I/O Block (G7TC-OC16-1, G7OD-SOC16-1, G7OD-FOM16-1, G7OA-ZOC16-4, or M7F).
G79-I□C-□	Connects a GT1-ID32ML or to an I/O Block (G7TC-I□16).
G79-0□C-□	Connects a GT1-OD32ML to an I/O Block (G7TC-OC16, G7TC-OC08, G7OD-SOC16, G7OD-FOM16, G7OA-ZOC16-3, or M7F).
	Connects a GT1-OD32ML-1 to an I/O Block (G7TC-OC16-1, G7OD-SOC16-1, G7OD-FOM16-1, or G7OA-ZOC16-4).
XW2Z-□□□A	Connects a GT1-ID16ML(-1) or GT1-OD16ML(-1) to a Connector-Terminal Block Conversion Unit (XW2B-20G4 or XW2B-20G5)
XW2X-□□□B	Connects a GT1-ID32ML(-1) or GT1-OD32ML(-1) to a Connector-Terminal Block Conversion Unit (XW2B-40G4 or XW2B-40G5)

Recommended Power Supplies for MULTIPLE I/O TERMINAL Units

Model	Specifications
S82K-05024	100 V AC, 50 W
S82K-10024	100 V AC, 100 W
S82J-5524	100 V AC, 50 W
S82J-5024	100 V AC, 100 W

Appendix B

Dimensions of Connectable Devices

Connectors for Node Connections

XW4B-05C1-H1-D Straight Connector with Attachment Screws

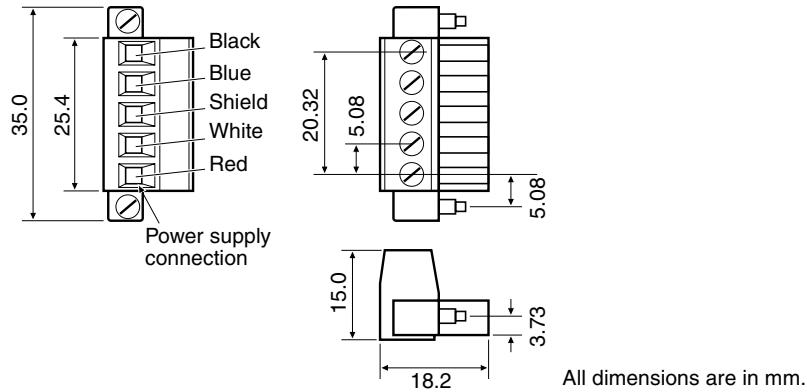

MSTB2.5/5-ST-5.08AU Straight Connector without Attachment Screws

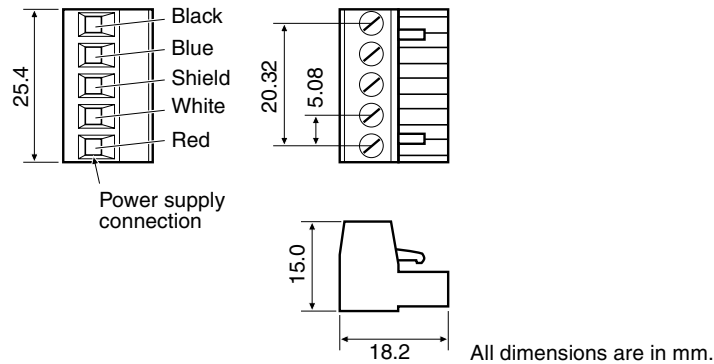

XW4B-05C1-VIR-D Right-angle Connector with Attachment Screws

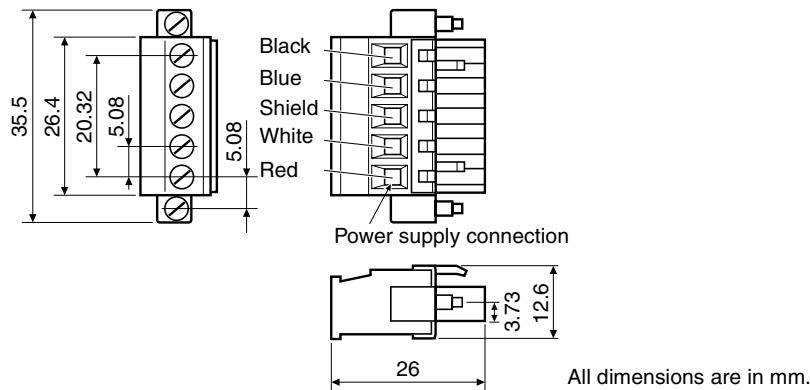

XW4G-05C1-H1-D

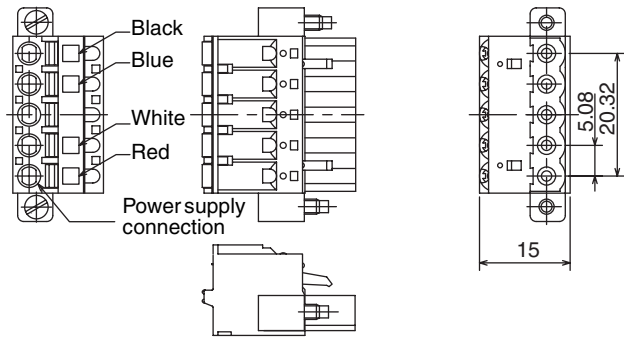

All dimensions are in mm.

XW4B-05C4-TF-D Straight Multi-drop Connector with Attachment Screws

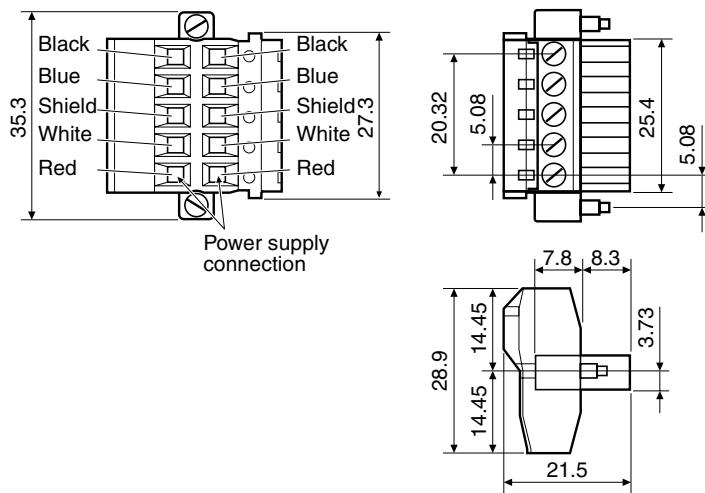

All dimensions are in mm.

XW4B-05C4-T-D Straight Multi-drop Connector without Attachment Screws

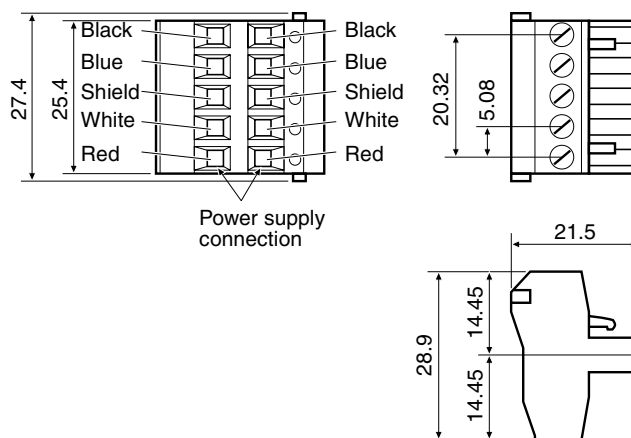

All dimensions are in mm.

XW4G-05C4-TF-D

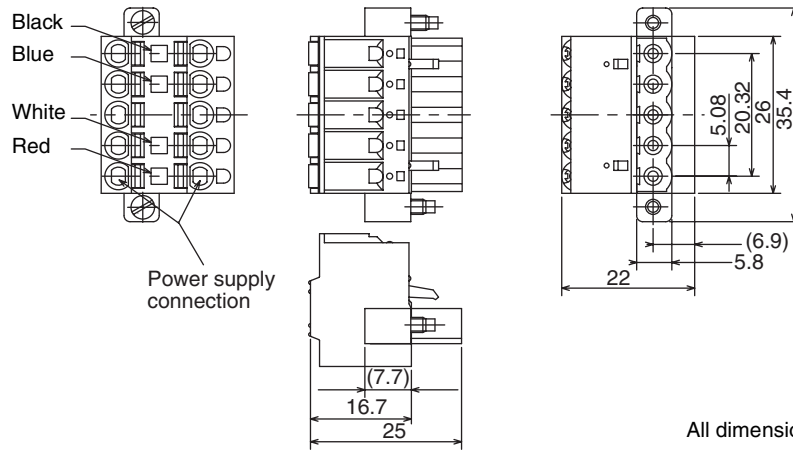

All dimensions are in mm.

DCN4-SF4D Flat Cable Connector

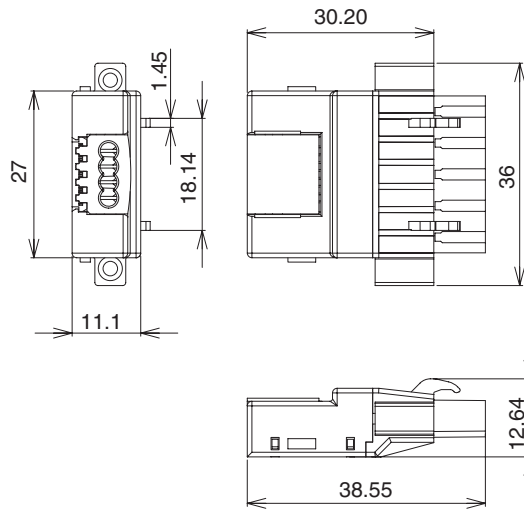

All dimensions are in mm.

T-branch Taps

DCN1-1NC T-branch Tap (Single Branch)

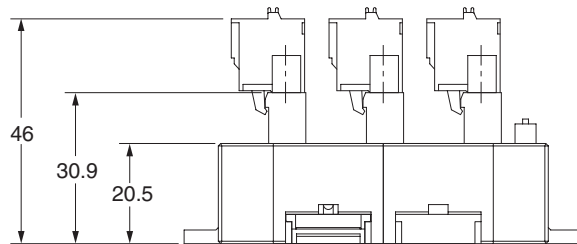
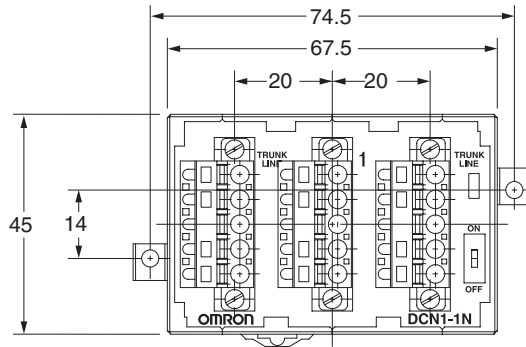

Mounting holes or taps

Two, 3.5 ± 0.1 -dia. or M3

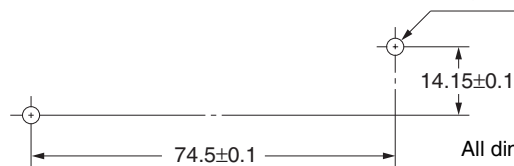

All dimensions are in mm.

DCN1-1C T-branch Tap (Single Branch)

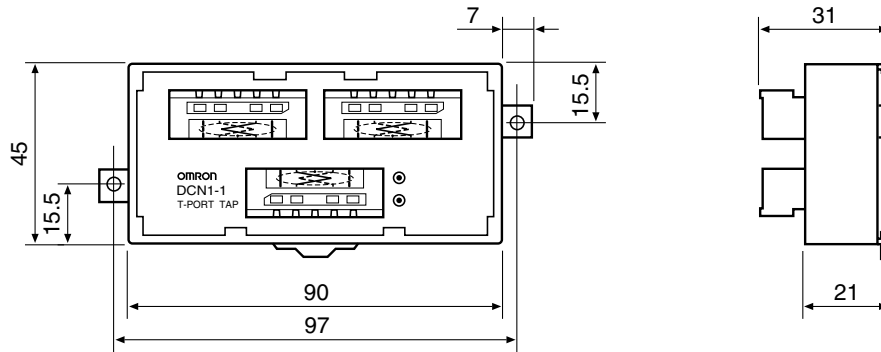

Mounting holes or taps

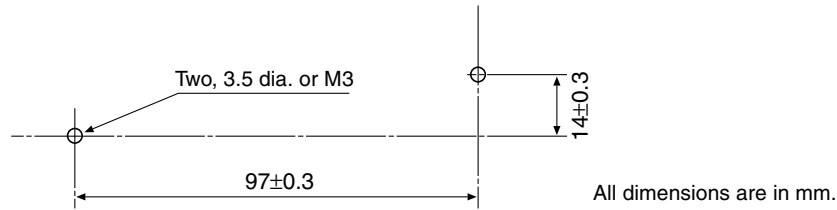

DCN1-2C and DCN1-2R T-branch Taps (Single Branches)

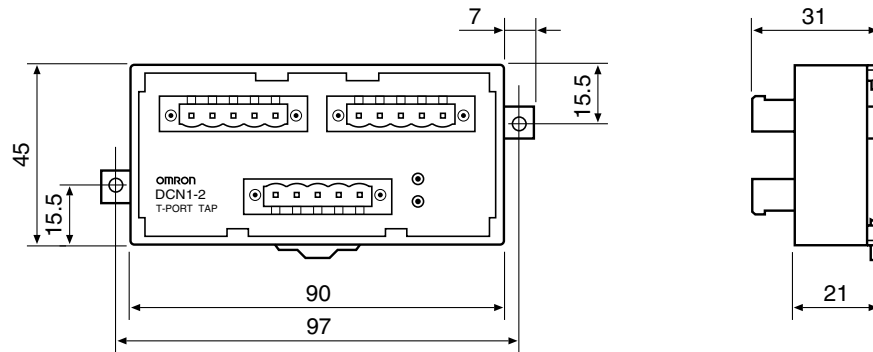

Mounting holes or taps

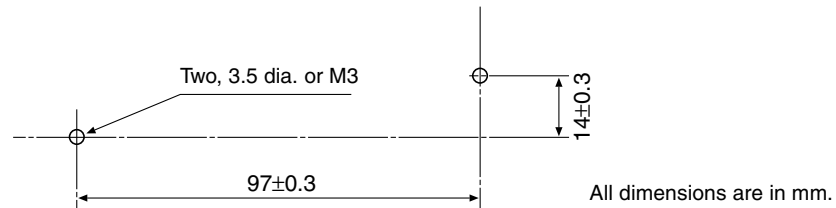

DCN1-3NC T-branch Tap (Three Branches)

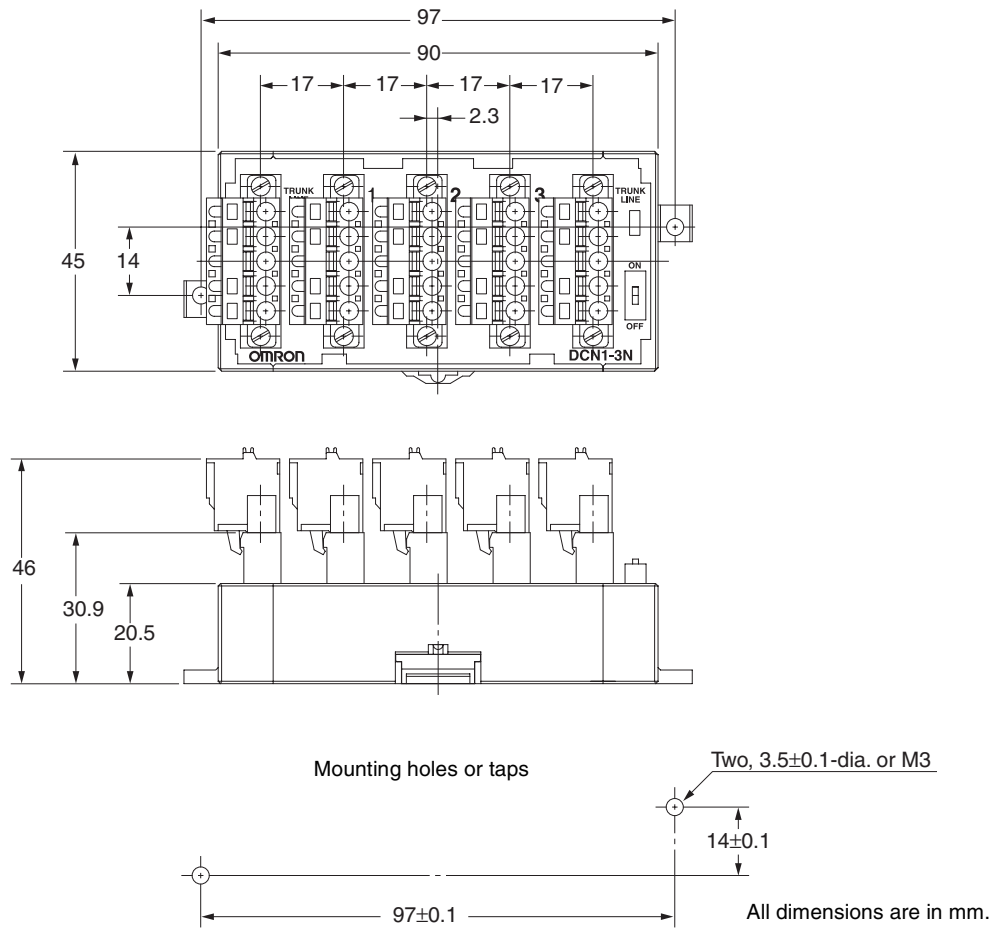

DCN1-3C T-branch Tap (Three Branches)

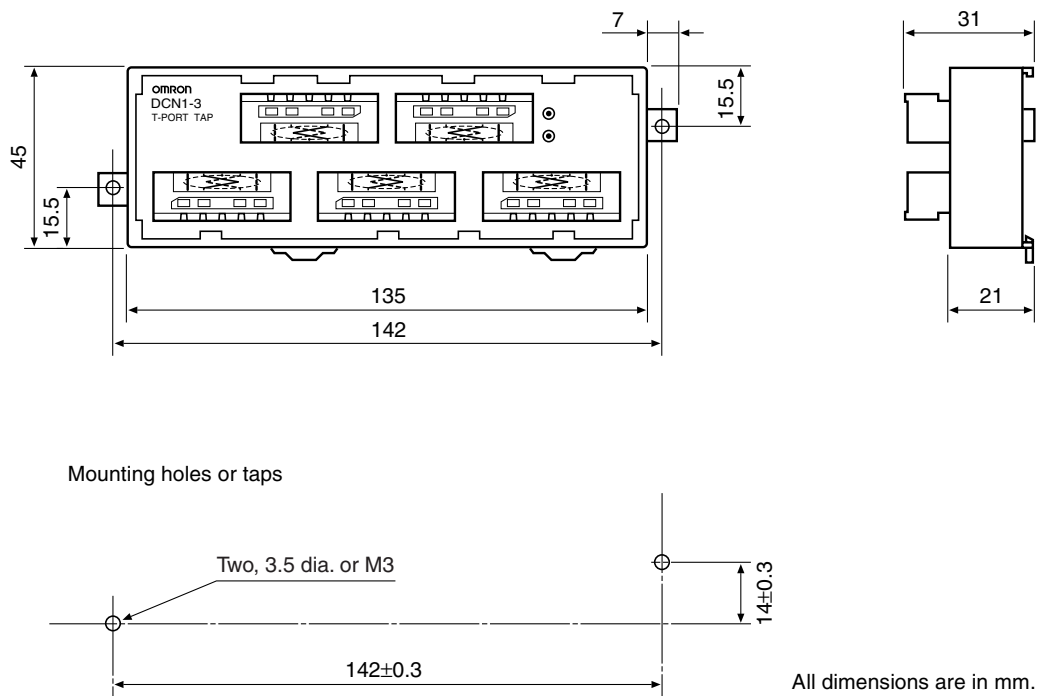

DCN1-4C and DCN1-4R T-branch Taps (Three Branches)

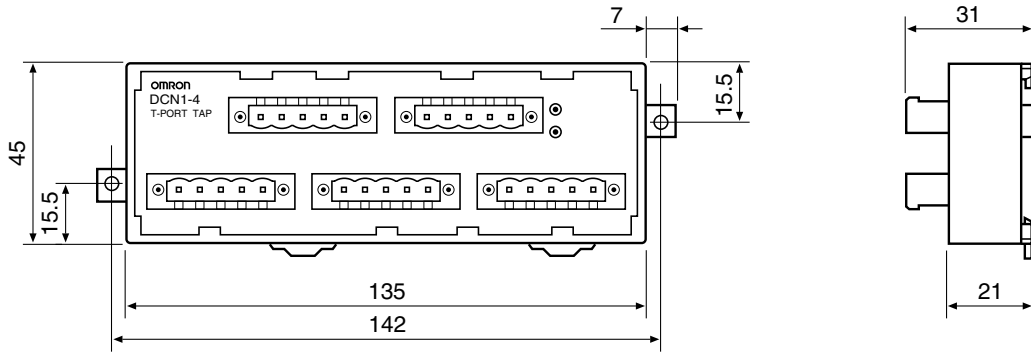

Mounting holes or taps

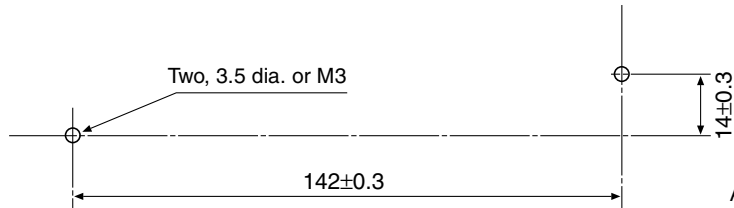

All dimensions are in mm.

T-branch Connectors

DCN2-1 T-branch Connector

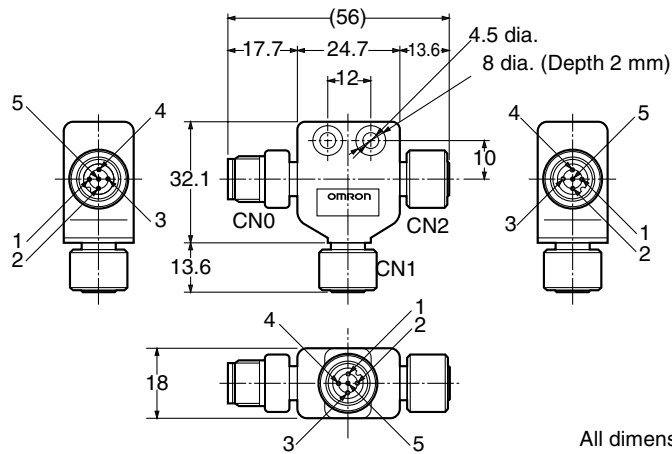

All dimensions are in mm.

DCN3-11 T-branch Connector

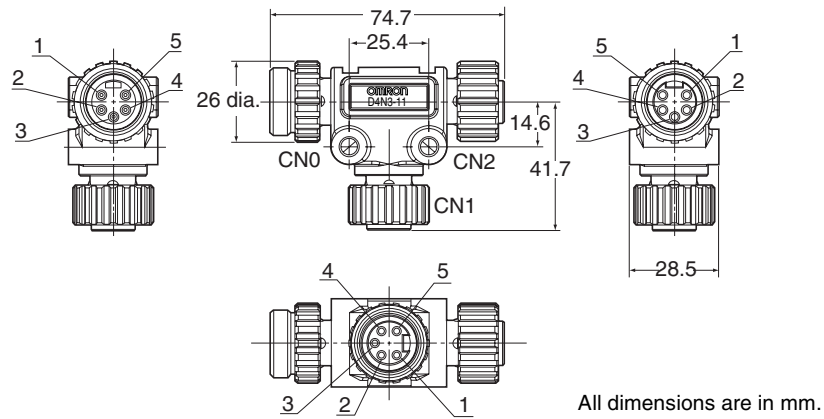

DCN3-12 T-branch Connector

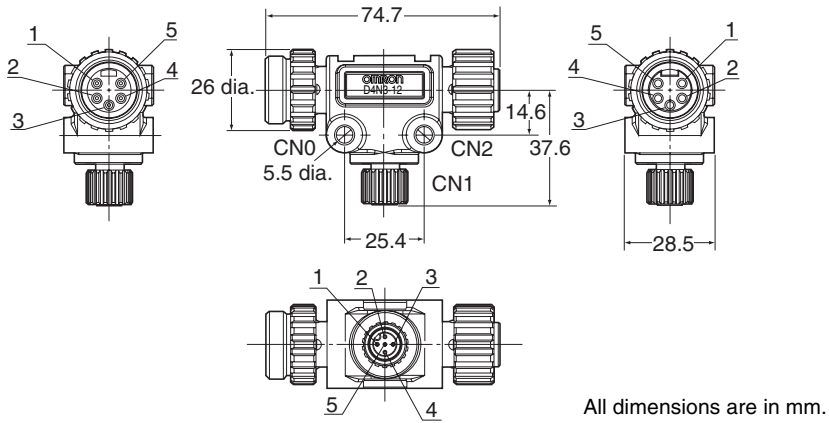

DCN1-1P Power Supply Tap

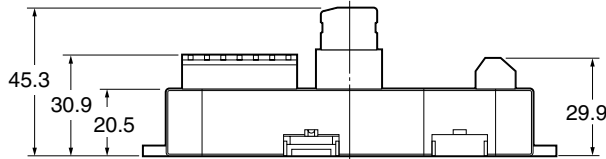
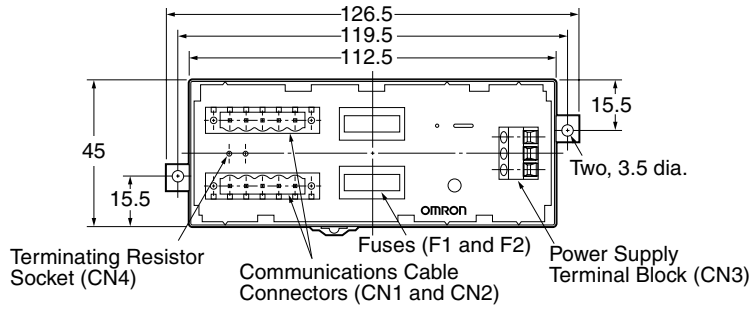

Mounting holes or taps

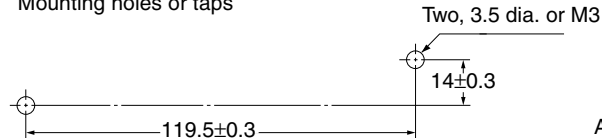

All dimensions are in mm.

Flat Cable Connectors

DCN4-TR4-1 Flat Connector Socket

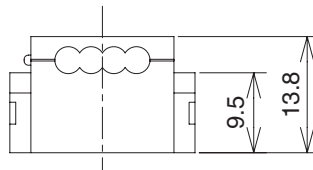
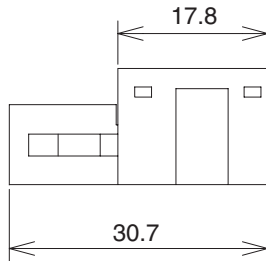
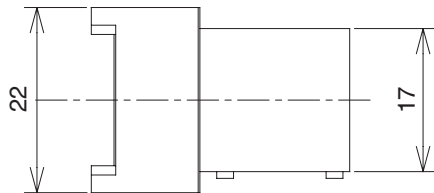

All dimensions are in mm.

DCN4-BR4 Flat Connector Plug

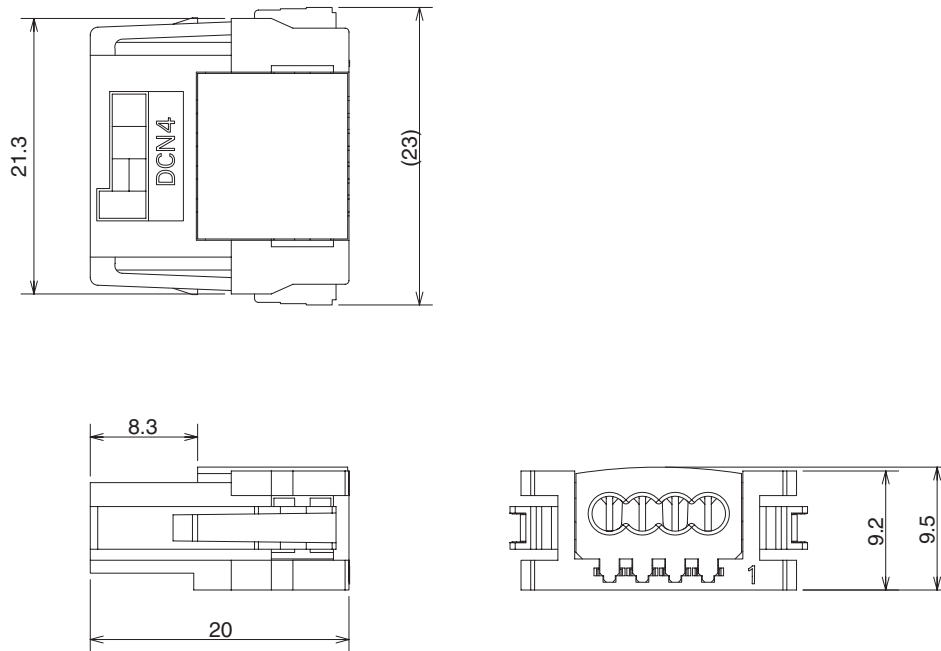

DCN4-BR4D Thin Cable-Flat Cable Conversion Connector

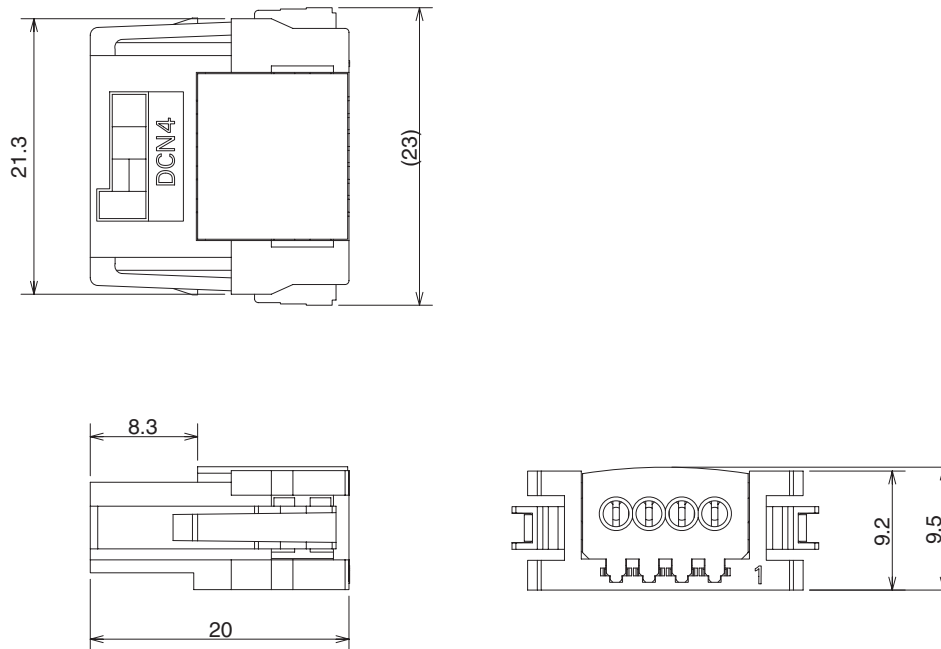

Terminating Resistors

DRS1-T Terminal-block Terminating Resistor

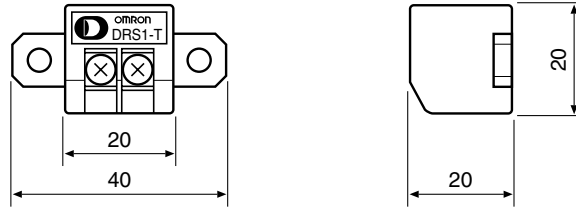

Mounting holes or taps

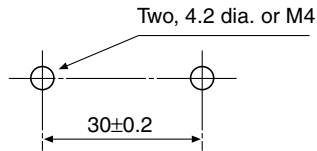

All dimensions are in mm.

DRS2-1 and DRS2-2 Shielded Micro-size (M12) Terminators

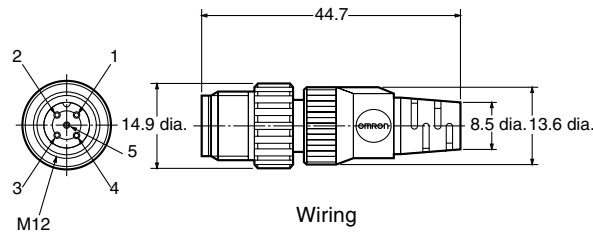

Wiring

Pin	Name
1	DRAIN : NC
2	V+ : NC
3	V- : NC
4	CAN H :
5	CAN L : $\approx 121 \Omega$

All dimensions are in mm.

Note The terminating resistance (121 Ω) is connected across pins 4 and 5.

DRS3-1 Shielded Mini-size Terminator

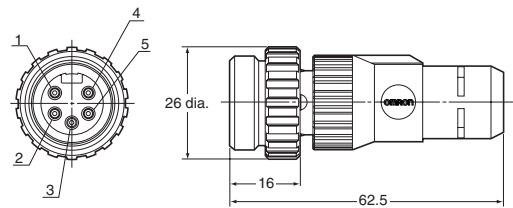

Wiring

Pin	Name
1	DRAIN : NC
2	V+ : NC
3	V- : NC
4	CAN H :
5	CAN L : $\approx 121 \Omega$

All dimensions are in mm.

Note The terminating resistance (121 Ω) is connected across pins 4 and 5.

DCN4-TP4D Flat Cable Power Supply Terminal Block with Terminating Resistance

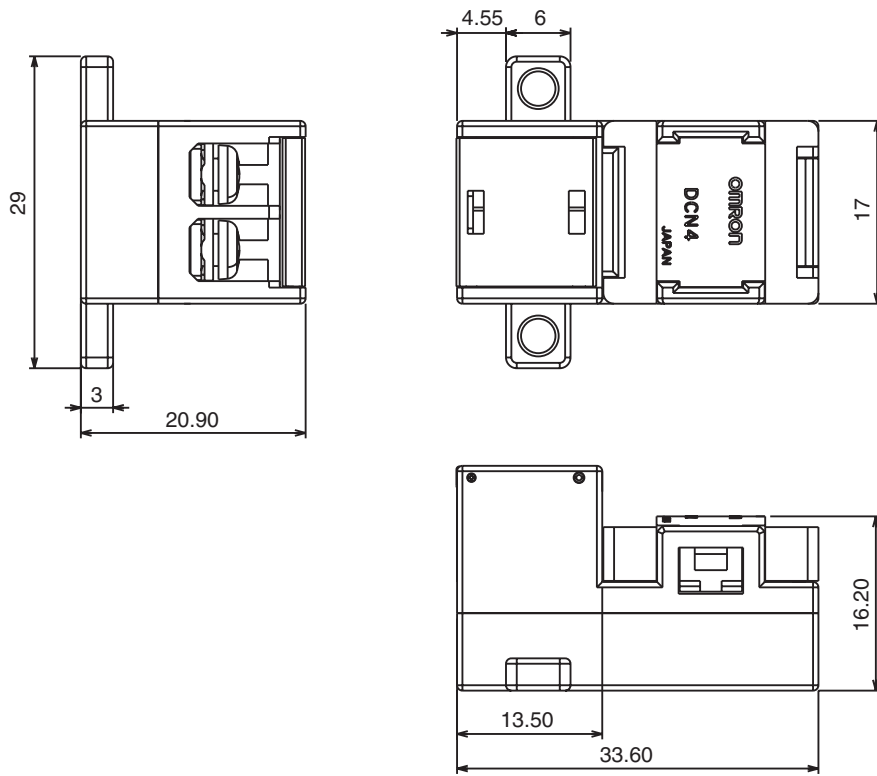

All dimensions are in mm.

Appendix C

Current Consumption of DeviceNet Devices

Master Units

Model	Internal current consumption	Communications current consumption
CS1W-DRM21(-V1)	290 mA max.	30 mA max.
CJ1W-DRM21	290 mA max.	18 mA max.
CVM1-DRM21-V1	250 mA max.	45 mA max.
C200HW-DRM21-V1	250 mA max.	45 mA max.
3G8F7-DRM21	290 mA max.	30 mA max.

Slave Units

DRT2-series General-purpose Slaves

Model	Communications current consumption
DRT2-ID16	60 mA max.
DRT2-ID16-1	60 mA max.
DRT2-OD16	60 mA max.
DRT2-OD16-1	60 mA max.
DRT2-ROS16	395 mA max.
XWT-ID08 (See note.)	5 mA max.
XWT-ID08-1 (See note.)	5 mA max.
XWT-ID16 (See note.)	10 mA max.
XWT-ID16-1 (See note.)	10 mA max.
XWT-OD08 (See note.)	4.5 mA max.
XWT-OD08-1 (See note.)	4.5 mA max.
XWT-OD16 (See note.)	10 mA max.
XWT-OD16-1 (See note.)	10 mA max.
DRT2-ID16TA	80 mA max.
DRT2-ID16TA-1	80 mA max.
DRT2-OD16TA	80 mA max.
DRT2-OD16TA-1	80 mA max.
DRT2-MD16TA	80 mA max.
DRT2-MD16TA-1	80 mA max.
DRT2-ID16S	230 mA max.
DRT2-ID16S-1	230 mA max.
DRT2-MD16S	135 mA max.
DRT2-MD16S-1	135 mA max.
DRT2-ID32ML	100 mA max.
DRT2-ID32ML-1	100 mA max.
DRT2-OD32ML	120 mA max.
DRT2-OD32ML-1	120 mA max.
DRT2-MD32ML	110 mA max.
DRT2-MD32ML-1	110 mA max.
DRT2-ID32B	100 mA max.
DRT2-ID32B-1	100 mA max.
DRT2-OD32B	120 mA max.
DRT2-OD32B-1	120 mA max.
DRT2-MD32B	110 mA max.
DRT2-MD32B-1	110 mA max.
DRT2-ID32BV	100 mA max.
DRT2-ID32BV-1	100 mA max.
DRT2-OD32BV	120 mA max.
DRT2-OD32BV-1	120 mA max.
DRT2-MD32BV	110 mA max.
DRT2-MD32BV-1	110 mA max.
DRT2-ID16SL	28 mA max.
DRT2-ID16SL-1	27 mA max.
DRT2-OD16SL	32 mA max.
DRT2-OD16SL-1	31 mA max.

Model	Communications current consumption
DRT2-ID16SLH	33 mA max.
DRT2-ID16SLH-1	32 mA max.
DRT2-OD16SLH	35 mA max.
DRT2-OD16SLH-1	35 mA max.
DRT2-ID32SL	100 mA max.
DRT2-ID32SL-1	90 mA max.
DRT2-OD32SL	80 mA max.
DRT2-OD32SL-1	75 mA max.
DRT2-MD32SL	80 mA max.
DRT2-MD32SL-1	80 mA max.
DRT2-ID32SLH	100 mA max.
DRT2-ID32SLH-1	105 mA max.
DRT2-OD32SLH	80 mA max.
DRT2-OD32SLH-1	85 mA max.
DRT2-MD32SLH	90 mA max.
DRT2-MD32SLH-1	90 mA max.

Note The communications current consumption indicated for Expansion Units is the additional current consumed when the Expansion Unit is connected to a Basic Unit.

For example, the current consumption for a combination of a DRT2-ID16 Basic Unit and an XWT-OD16 Expansion Unit is $60 + 10 = 70$ mA.

DRT1-series General-purpose Slaves

Model	Internal current consumption	Communications current consumption
DRT1-ID08	50 mA max.	30 mA max.
DRT1-ID08-1	50 mA max.	30 mA max.
DRT1-ID16	50 mA max.	30 mA max.
DRT1-ID16-1	50 mA max.	30 mA max.
DRT1-OD08	50 mA max.	30 mA max.
DRT1-OD08-1	50 mA max.	30 mA max.
DRT1-OD16	50 mA max.	30 mA max.
DRT1-OD16-1	50 mA max.	30 mA max.
DRT1-MD16	50 mA max.	25 mA max.
DRT1-ID16T	90 mA max.	30 mA max.
DRT1-ID16T-1	90 mA max.	30 mA max.
DRT1-ID16TA	(Shares communications power supply.)	50 mA max.
DRT1-ID16TA-1	(Shares communications power supply.)	50 mA max.
DRT1-OD16T	90 mA max.	30 mA max.
DRT1-OD16T-1	90 mA max.	30 mA max.
DRT1-OD16TA	(Shares communications power supply.)	50 mA max.
DRT1-OD16TA-1	(Shares communications power supply.)	50 mA max.
DRT1-MD16T	90 mA max.	30 mA max.
DRT1-MD16T-1	90 mA max.	30 mA max.
DRT1-MD16TA	(Shares communications power supply.)	50 mA max.
DRT1-MD16TA-1	(Shares communications power supply.)	50 mA max.
DRT1-ID32ML	(Shares communications power supply.)	50 mA max.
DRT1-ID32ML-1	(Shares communications power supply.)	50 mA max.
DRT1-OD32ML	(Shares communications power supply.)	90 mA max.
DRT1-OD32ML-1	(Shares communications power supply.)	90 mA max.

Model	Internal current consumption	Communications current consumption
DRT1-MD32ML	(Shares communications power supply.)	70 mA max.
DRT1-MD32ML-1	(Shares communications power supply.)	70 mA max.
DRT1-ID16X	70 mA max.	30 mA max.
DRT1-ID16X-1	70 mA max.	30 mA max.
DRT1-OD16X	70 mA max.	30 mA max.
DRT1-OD16X-1	70 mA max.	30 mA max.
DRT1-HD16S	60 mA max.	40 mA max.
DRT1-ND16S	60 mA max.	40 mA max.
CQM1-DRT21	80 mA max. (Supplied from the 5 V DC base.)	40 mA max.
CPM1A-DRT21	50 mA max.	30 mA max.

DRT2-series Environment-resistive Slaves

Model	Communications current consumption
DRT2-ID08C	115 mA max.
DRT2-ID08C-1	115 mA max.
DRT2-HD16C	190 mA max.
DRT2-HD16C-1	190 mA max.
DRT2-OD08C	60 mA max.
DRT2-OD08C-1	60 mA max.
DRT2-ID04CL	50 mA max.
DRT2-ID04CL-1	50 mA max.
DRT2-ID08CL	50 mA max.
DRT2-ID08CL-1	50 mA max.
DRT2-HD16CL	55 mA max.
DRT2-HD16CL-1	55 mA max.
DRT2-OD04CL	45 mA max.
DRT2-OD04CL-1	45 mA max.
DRT2-OD08CL	50 mA max.
DRT2-OD08CL-1	50 mA max.
DRT2-WD16CL	55 mA max.
DRT2-WD16CL-1	55 mA max.
DRT2-MD16CL	55 mA max.
DRT2-MD16CL-1	55 mA max.

DRT1-series Environment-resistive Slaves

Model	Internal current consumption	Communications current consumption
DRT1-ID04CL	(Shares communications power supply.)	25 mA max.
DRT1-ID04CL-1	(Shares communications power supply.)	25 mA max.
DRT1-ID08CL	(Shares communications power supply.)	30 mA max.
DRT1-ID08CL-1	(Shares communications power supply.)	30 mA max.
DRT1-ID08C	50 mA max.	30 mA max.
DRT1-HD16C	50 mA max.	30 mA max.
DRT1-HD16C-1	50 mA max.	30 mA max.
DRT1-OD04CL	(Shares communications power supply.)	35 mA max.
DRT1-OD04CL-1	(Shares communications power supply.)	35 mA max.
DRT1-OD08CL	(Shares communications power supply.)	40 mA max.
DRT1-OD08CL-1	(Shares communications power supply.)	40 mA max.
DRT1-OD08C	50 mA max.	30 mA max.

Model	Internal current consumption	Communications current consumption
DRT1-WD16C	60 mA max.	30 mA max.
DRT1-WD16C-1	60 mA max.	30 mA max.
DRT1-MD16C	50 mA max.	30 mA max.
DRT1-MD16C-1	50 mA max.	30 mA max.
DRT1-B7AC	500 mA max.	70 mA max.

DRT2-series Analog Slaves

Model	Communications current consumption
DRT2-AD04	90 mA max.
DRT2-AD04H	70 mA max.
DRT2-DA02	120 mA max.
DRT2-TS04T	70 mA max.
DRT2-TS04P	70 mA max.

DRT1-series Special I/O Slaves Units

Model	Internal current consumption	Communications current consumption
CPM2C-S100C-DRT CPM2C-S110C-DRT	170 mA max.	30 mA max.
C200HW-DRT21	250 mA max. (Supplied from the 5 V DC base.)	45 mA max.
DRT1-232C2	100 mA max.	50 mA max.

MULTIPLE I/O TERMINALS

Communications Unit

Model	Internal current consumption	Communications current consumption
DRT1-COM	110 mA max.	30 mA max.

I/O Units

Model	I/O Unit interface current consumption	Internal and I/O current consumption
GT1-ID16(-1)	35 mA max.	---
GT1-ID16MX(-1)	35 mA max.	---
GT1-ID16ML(-1)	35 mA max.	---
GT1-ID16DS(-1)	35 mA max.	---
GT1-ID32ML(-1)	55 mA max.	---
GT1-OD16(-1)	35 mA max.	9 mA max.
GT1-OD16MX(-1)	35 mA max.	9 mA max.
GT1-OD16ML(-1)	35 mA max.	9 mA max.
GT1-OD16DS(-1)	35 mA max.	9 mA max.
GT1-OD32ML(-1)	65 mA max.	11 mA max.
GT1-ROP08	40 mA max.	350 mA max. (Inrush current 30 A max.)
GT1-ROS16	50 mA max.	250 mA max. (Inrush current 30 A max.)
GT1-AD04	50 mA max.	Internal power supply: 100 mA max. (Inrush current 20 A max.)
GT1-AD08MX	50 mA max.	Internal power supply: 100 mA max. (Inrush current 30 A max.)
GT1-DA04	50 mA max.	Internal power supply: 150 mA max. (Inrush current 20 A max.)
GT1-DA04MX	50 mA max.	Internal power supply: 100 mA max. (Inrush current 30 A max.)
GT1-TS04T	50 mA max.	Internal power supply: 80 mA max. (Inrush current 10 A max.)

Model	I/O Unit interface current consumption	Internal and I/O current consumption
GT1-TS04P	50 mA max.	Internal power supply: 80 mA max. (Inrush current 10 A max.)
GT1-CT01	90 mA max.	9 mA max.

Index

A

- adapters
 - remote, 8
- assembly
 - precautions, xxi

B

- branch lines
 - current capacity, 88
 - reducing length, 35

C

- cables
 - combining thick and thin, 37
 - communications cables, xxii, 43
 - connecting, 46, 62
 - distance, 45
 - specifications, 46
 - current capacity, 27, 34, 37, 88
 - I/O Unit Connecting Cable, 16
 - limitations, 37
 - models, 32, 43, 116, 117
 - precautions, xxii
 - proper usage, 37
 - selecting, 37
 - shielded, 76
 - special applications, 33
 - thin cable applications, 38
 - trunk/branch lines, 23, 26, 27, 33
 - types, 33, 34, 37
 - wiring, 54
- circuits
 - emergency stop, xviii
 - external, xviii
- communications
 - cables
 - connecting, 62
 - distance, 45
 - models, 110
 - specifications, 46
 - message communications, 3, 6
 - power supply, 25, 31, 41
 - details, 87
 - problems, 84
 - specifications, 61
 - wiring, 76
 - remote I/O communications, 3

- specifications, 17
- compatible devices, 4
- Configurator, 3, 17
 - models, 103
- connection methods
 - branching patterns, 28, 30
 - communications cables, 46, 62
 - multi-drop, 24
 - with multi-drop connector, 65
 - with standard connector, 65
 - T-branch, 24, 69
 - Terminating Resistors, 40, 60, 78
- connectors
 - for node connections, 48
 - insertion direction, 54
 - models, 48, 49, 51, 111, 114, 117
 - RS-232C, 116
 - multi-drop, 51
 - wiring, 52, 65
 - precautions, xxi
 - shielded, 49, 68
 - standard, 48, 65
 - wiring, 62
 - T-branch, 57
 - wiring, 52, 62
- crimp terminals
 - models, 112

D

- DeviceNet Configurator, 3, 17
 - models, 103
- DIP switches
 - precautions, xxi

E

- emergency stop circuits, xviii

F

- features, DeviceNet, 2
- functions, 4
 - DeviceNet Configurator, 17
 - message communications, 6
 - Remote I/O Master, 4
 - Remote I/O Slave, 5

G

grounding, xxi, 25, 32, 42, 80

I

I/O Link Units

 C200H I/O Link Unit, 10

 CQM 1 I/O Link Unit, 8

I/O Terminals

 environment-resistant, 9

 water-resistant, 9

I/O Units

 connecting cable, 16

M

Master Units

 current consumption, 131

 determining location, 39

 DeviceNet functions, 4

 models, 4, 103

models

 Boards, 17

 cables, 32, 43, 110, 116, 117

 Cards, 17

 Configurator, 17, 103

 connectors, 48, 49, 51, 111, 114, 117

 RS-232C, 116

 crimp terminals, 112

 Master Units, 4, 103

 Mounting Brackets, 116

 MULTIPLE I/O TERMINAL Units, 15, 109

 power supply, 118

 Power Supply Tap, 114

 Slaves, 7, 9, 10, 104

 T-branch Connectors, 58, 113

 T-branch Taps, 53

 Terminating Resistors, 60

 Three-branch Taps, 113

Mounting Brackets

 models, 116

MULTIPLE I/O TERMINAL Units

 current consumption, 135

 models, 15, 109

N

network

 configuration, 18, 21, 22, 32

 maximum length, 34

 nodes, 23, 24, 33, 43

 noise, 82, 84

 start-up procedure, 18

 wiring, 18, 21

nodes

 allocating node numbers, 43

 connecting to, 69

 connectors for, 48

noise

 malfunctions due to, 84

 minimizing, 82

P

packing, xxii

power supply

 communications, 25, 31, 41, 97

 details, 87

 problems, 84

 specifications, 61

 wiring, 76

 determining requirements, 89

 internal circuit, 41, 97

 layout patterns, 90

 location, 90

 models, 118

 multiple power supplies, 101

 precautions, xxi

 voltage drop, 97

Power Supply Tap, 59, 88

 configuration, 101

 internal circuits, 101

 models, 114

precautions

 application, xxi

 operating environment, xx

 safety, xviii

profiles, 3

R

rotary switches

 precautions, xxi

RS-232C Units, 10

S

- safety precautions, xviii
- scan list, xxii, 19
- self-diagnosis function, xviii
- short-circuits
 - precautions, xxi
- slaves
 - connected in Network, 23
 - current consumption, 132
 - models, 7, 9, 104
 - special, 10
 - types of, 7
- Special I/O Units, 16
- specifications
 - communications, 17
 - communications cables, 46
 - communications power supply, 61
- shielded, 68
- standard, 62
- crimp terminals, 41
- DeviceNet Network, 18, 21
- precautions, xxi

T

- T-branch Connectors, 88
 - models, 58, 113
- T-branch Taps, 40, 52, 88
 - components, 55, 57
 - connecting to, 69
 - models, 53
- terminals
 - B7AC Interface Terminal, 9
 - precautions, xxii
 - remote I/O, 7
 - sensor, 8
- Terminating Connectors
 - connecting, 60
- Terminating Resistors, 24, 32, 33
 - connecting, 40, 78
 - models, 60
- Three-branch Taps
 - models, 113
- trunk lines
 - selecting, 36

W

- wiring
 - cables, 54
 - communications power supply, 76
 - connectors
 - multi-drop, 52

Revision History

A manual revision code appears as a suffix to the catalog number on the front cover of the manual.

Cat. No. W267-E1-11



The following table outlines the changes made to the manual during each revision. Page numbers refer to the previous version.

Revision code	Date	Revised content	
1	August 1996	Original production	
2	June 1997	Complete revision to include V1 Master Units.	
3	December 1997	<p>The manual was revised to include new information on network configuration and wiring, and Temperature Input Terminals.</p> <p>Section 3: Added to include information on network configuration and specifications.</p> <p>Page 72: Changes to table.</p> <p>Pages 72 to 84: Additions made to include DRT1-AD04H.</p> <p>Pages 91 to 97: Information added on Temperature Input Terminals.</p>	<p>Section 6: Added to include information on the communications power supply.</p> <p>Section 7: Extensively revised to include information on wiring the network.</p> <p>Page 267: Information changed in table.</p> <p>Appendix F: Added to provide information on connectable devices and current consumption.</p>
4	April 1998	<p>The manual was revised to correct errors and include new information on multiple I/O terminals.</p> <p>Page 6: Table added to include information on MULTIPLE I/O TERMINAL.</p> <p>Page 34: Information on MULTIPLE I/O TERMINAL added.</p> <p>Pages 46, 51, 56, 60, 65, 72, 84, 91: Specifications corrected.</p> <p>Pages 47, 53, 58, 62, 67, 68, 76: "Insulated" corrected to "isolated."</p> <p>Pages 50, 56, 60, 64, 71, 84, 91, 98: Note on opening the cover removed.</p> <p>Page 92: Note on converted data removed.</p>	<p>Section 5-3: Added to include information on MULTIPLE I/O TERMINAL.</p> <p>Section 7-12: Added to include information on installation and connection of MULTIPLE I/O TERMINAL</p> <p>Pages 350 to 352: Information on MULTIPLE I/O TERMINAL response times and communications cycle times added.</p> <p>Pages 363 to 368: Error processing information for MULTIPLE I/O TERMINAL added.</p> <p>Page 407: Communications Unit device profile added.</p> <p>Page 418: Connectable device information updated to include MULTIPLE I/O TERMINAL.</p>
5	May 2000	<p>Changes were made throughout the manual to correct errors and include new information on CS1-series PLCs, Basic and Special I/O Units, MULTIPLE I/O TERMINAL Units, and Environment-resistant Terminals. "CompoBus/D" was changed to "DeviceNet" and "CV-series" was amended to "CVM1 and CV-series" throughout the manual.</p> <p>Pages 2, 7, 8, 22, 32, 37, 40, 185, 193, 208, 211, 212, 216, 220, 224, 227, 234-236, 239-242, 252-254, 313, 325, 328-335, 340, 345, 355, 356, 365, 371, 377-379: Information on CS1-series PLCs added.</p> <p>Pages 3-6: Major changes to model information.</p> <p>Pages 7, 15, 19, 341-347: Notes changed/added.</p> <p>Page 13: Correction made to information on communications cycle time.</p> <p>Pages 21, 27: Information on reference sources added/changed.</p> <p>Pages 23, 228: Information on communications setup added.</p> <p>Sections 5-1 to 5-3: Removed.</p> <p>Sections 5-4-8 to 5-4-12: Removed.</p> <p>Page 181: Information on dual power supply changed.</p>	<p>Page 184: Torque data changed. Information on mounting added.</p> <p>Section 7-2-2: Removed.</p> <p>Pages 187, 219, 226: Changes to graphics.</p> <p>Pages 190-192: Torque data changed.</p> <p>Sections 7-11, 7-12: Removed.</p> <p>Pages 204, 218, 384, 400, 401: Changes made to tables.</p> <p>Pages 234, 246, 253, 259, 260: Information on explicit messages added.</p> <p>Page 326: Information on error log data added.</p> <p>Pages 338-339: Changes made to information on communications cycle time. Information for networks with more than one Master moved to page 347.</p> <p>Pages 346-349: Equations changed/added.</p> <p>Section 14-1-3: Removed.</p> <p>Page 382: Information on troubleshooting for Analog I/O Units, Temperature Input Terminals, the C200H I/O Link Unit, and the RS-232C Unit added.</p> <p>Page 399: Change to introduction. Information on connection to other company's Masters removed.</p> <p>Pages 402-408: Removed.</p> <p>Appendix E: Removed.</p> <p>Appendix F: New model information added.</p>
6	October 2000	Reprinted due to error.	
07	August 2002	Completely redone to separate information on Masters into a separate manual, to add round connectors and other connectors, and to add T-branch Taps and other new products.	

Revision History

Revision code	Date	Revised content	
08	December 2003	<p>Changes were made throughout the manual to include information on new models, including connectors, T-branch taps and DRT2-series Smart Slaves. "PC" was also changed to "PLC" throughout the manual as the abbreviation for Programmable Controller.</p> <p>Pages 4, 5, 6: Added (-V1) suffix to models in table.</p> <p>Page 7: Added reference for DRT2-series models.</p> <p>Pages 11, 12: Added table of information on DRT2-series General-purpose Slaves.</p> <p>Pages 41, 43: Added new connector models to tables.</p> <p>Page 44: Added applicable DRT2-series models to note.</p> <p>Page 45: Added new T-branch Tap models to table.</p> <p>Pages 46, 47: Added diagrams of new T-branch Tap models.</p> <p>Page 53: Changed and added new information on cables and connectors.</p>	<p>Page 54: Added information for connectors without screws.</p> <p>Page 56: Added information on new connector model.</p> <p>Page 63: Changed "SYSMAC" to "PLC."</p> <p>Pages 83, 84: Added tables on DRT2-series Smart Slaves.</p> <p>Page 86: Added information on new models to table of communications cables and connectors.</p> <p>Page 87: Changed information in table of crimp terminals for communications cables.</p> <p>Pages 87, 88: Added information on new models to tables of single-branch and three-branch taps</p> <p>Pages 93, 94: Added dimensional diagrams for new connector models.</p> <p>Pages 95, 96: Added diagrams of new T-branch Tap models.</p> <p>Pages 101, 102: Added tables of information on DRT2-series Smart Slaves</p>
09	November 2004	<p>Minor changes were made, mainly to restructure information in tables of device lists, add information and correct minor errors, as follows:</p> <p>Page xiv: Added information on changing operating mode.</p> <p>Pages 11, 12, 90, 92, 111, and 113: Added new models to tables.</p> <p>Pages 28 and 65: Added information on power supply.</p>	<p>Page 37: Changed resistance values from "60 Ω" to "70 Ω" and from "200 to 300 Ω" to "300 Ω or higher."</p> <p>Page 55: Changed "S82H-series and S82J-series" to "S82J-series and S82K-series."</p> <p>Pages 91 and 112: Moved DRT1-series Analog Slaves to separate table after DRT1-series Analog Slaves.</p> <p>Page 106: Changed width from "11" to "12" in diagram.</p>
10	August 2005	<p>Page v: Information on general precautions notation added.</p> <p>Page xi: Information on liability and warranty added.</p>	
11	April 2008	<p>Changes were made throughout the manual to add the DRT2-series Slave Units and Special Flat Cable, to correct errors, and to add descriptions.</p>	

Terms and Conditions of Sale

1. **Offer; Acceptance.** These terms and conditions (these "Terms") are deemed part of all quotes, agreements, purchase orders, acknowledgments, price lists, catalogs, manuals, brochures and other documents, whether electronic or in writing, relating to the sale of products or services (collectively, the "Products") by Omron Electronics LLC and its subsidiary companies ("Omron"). Omron objects to any terms or conditions proposed in Buyer's purchase order or other documents which are inconsistent with, or in addition to, these Terms.
2. **Prices; Payment Terms.** All prices stated are current, subject to change without notice by Omron. Omron reserves the right to increase or decrease prices on any unshipped portions of outstanding orders. Payments for Products are due net 30 days unless otherwise stated in the invoice.
3. **Discounts.** Cash discounts, if any, will apply only on the net amount of invoices sent to Buyer after deducting transportation charges, taxes and duties, and will be allowed only if (i) the invoice is paid according to Omron's payment terms and (ii) Buyer has no past due amounts.
4. **Interest.** Omron, at its option, may charge Buyer 1-1/2% interest per month or the maximum legal rate, whichever is less, on any balance not paid within the stated terms.
5. **Orders.** Omron will accept no order less than \$200 net billing.
6. **Governmental Approvals.** Buyer shall be responsible for, and shall bear all costs involved in, obtaining any government approvals required for the importation or sale of the Products.
7. **Taxes.** All taxes, duties and other governmental charges (other than general real property and income taxes), including any interest or penalties thereon, imposed directly or indirectly on Omron or required to be collected directly or indirectly by Omron for the manufacture, production, sale, delivery, importation, consumption or use of the Products sold hereunder (including customs duties and sales, excise, use, turnover and license taxes) shall be charged to and remitted by Buyer to Omron.
8. **Financial.** If the financial position of Buyer at any time becomes unsatisfactory to Omron, Omron reserves the right to stop shipments or require satisfactory security or payment in advance. If Buyer fails to make payment or otherwise comply with these Terms or any related agreement, Omron may (without liability and in addition to other remedies) cancel any unshipped portion of Products sold hereunder and stop any Products in transit until Buyer pays all amounts, including amounts payable hereunder, whether or not then due, which are owing to it by Buyer. Buyer shall in any event remain liable for all unpaid accounts.
9. **Cancellation; Etc.** Orders are not subject to rescheduling or cancellation unless Buyer indemnifies Omron against all related costs or expenses.
10. **Force Majeure.** Omron shall not be liable for any delay or failure in delivery resulting from causes beyond its control, including earthquakes, fires, floods, strikes or other labor disputes, shortage of labor or materials, accidents to machinery, acts of sabotage, riots, delay in or lack of transportation or the requirements of any government authority.
11. **Shipping; Delivery.** Unless otherwise expressly agreed in writing by Omron:
 - a. Shipments shall be by a carrier selected by Omron; Omron will not drop ship except in "break down" situations.
 - b. Such carrier shall act as the agent of Buyer and delivery to such carrier shall constitute delivery to Buyer;
 - c. All sales and shipments of Products shall be FOB shipping point (unless otherwise stated in writing by Omron), at which point title and risk of loss shall pass from Omron to Buyer; provided that Omron shall retain a security interest in the Products until the full purchase price is paid;
 - d. Delivery and shipping dates are estimates only; and
 - e. Omron will package Products as it deems proper for protection against normal handling and extra charges apply to special conditions.
12. **Claims.** Any claim by Buyer against Omron for shortage or damage to the Products occurring before delivery to the carrier must be presented in writing to Omron within 30 days of receipt of shipment and include the original transportation bill signed by the carrier noting that the carrier received the Products from Omron in the condition claimed.
13. **Warranties.** (a) **Exclusive Warranty.** Omron's exclusive warranty is that the Products will be free from defects in materials and workmanship for a period of twelve months from the date of sale by Omron (or such other period expressed in writing by Omron). Omron disclaims all other warranties, express or implied. (b) **Limitations.** OMRON MAKES NO WARRANTY OR REPRESENTATION, EXPRESS OR IMPLIED, ABOUT NON-INFRINGEMENT, MERCHANTABILITY OR FITNESS FOR A PARTICULAR PURPOSE OF THE PRODUCTS. BUYER ACKNOWLEDGES THAT IT ALONE HAS DETERMINED THAT THE PRODUCTS WILL SUITABLY MEET THE REQUIREMENTS OF THEIR INTENDED USE. Omron further disclaims all warranties and responsibility of any type for claims or expenses based on infringement by the Products or otherwise of any intellectual property right. (c) **Buyer Remedy.** Omron's sole obligation hereunder shall be, at Omron's election, to (i) replace (in the form originally shipped with Buyer responsible for labor charges for removal or replacement thereof) the non-complying Product, (ii) repair the non-complying Product, or (iii) repay or credit Buyer an amount equal to the purchase price of the non-complying Product; provided that in no event shall Omron be responsible for warranty, repair, indemnity or any other claims or expenses regarding the Products unless Omron's analysis confirms that the Products were properly handled, stored, installed and maintained and not subject to contamination, abuse, misuse or inappropriate modification. Return of any Products by Buyer must be approved in writing by Omron before shipment. Omron Companies shall not be liable for the suitability or unsuitability or the results from the use of Products in combination with any electrical or electronic components, circuits, system assemblies or any other materials or substances or environments. Any advice, recommendations or information given orally or in writing, are not to be construed as an amendment or addition to the above warranty. See <http://www.omron247.com> or contact your Omron representative for published information.
14. **Limitation on Liability; Etc.** OMRON COMPANIES SHALL NOT BE LIABLE FOR SPECIAL, INDIRECT, INCIDENTAL, OR CONSEQUENTIAL DAMAGES, LOSS OF PROFITS OR PRODUCTION OR COMMERCIAL LOSS IN ANY WAY CONNECTED WITH THE PRODUCTS, WHETHER SUCH CLAIM IS BASED IN CONTRACT, WARRANTY, NEGLIGENCE OR STRICT LIABILITY. Further, in no event shall liability of Omron Companies exceed the individual price of the Product on which liability is asserted.
15. **Indemnities.** Buyer shall indemnify and hold harmless Omron Companies and their employees from and against all liabilities, losses, claims, costs and expenses (including attorney's fees and expenses) related to any claim, investigation, litigation or proceeding (whether or not Omron is a party) which arises or is alleged to arise from Buyer's acts or omissions under these Terms or in any way with respect to the Products. Without limiting the foregoing, Buyer (at its own expense) shall indemnify and hold harmless Omron and defend or settle any action brought against such Companies to the extent based on a claim that any Product made to Buyer specifications infringed intellectual property rights of another party.
16. **Property; Confidentiality.** Any intellectual property in the Products is the exclusive property of Omron Companies and Buyer shall not attempt to duplicate it in any way without the written permission of Omron. Notwithstanding any charges to Buyer for engineering or tooling, all engineering and tooling shall remain the exclusive property of Omron. All information and materials supplied by Omron to Buyer relating to the Products are confidential and proprietary, and Buyer shall limit distribution thereof to its trusted employees and strictly prevent disclosure to any third party.
17. **Export Controls.** Buyer shall comply with all applicable laws, regulations and licenses regarding (i) export of products or information; (ii) sale of products to "forbidden" or other proscribed persons; and (iii) disclosure to non-citizens of regulated technology or information.
18. **Miscellaneous.** (a) **Waiver.** No failure or delay by Omron in exercising any right and no course of dealing between Buyer and Omron shall operate as a waiver of rights by Omron. (b) **Assignment.** Buyer may not assign its rights hereunder without Omron's written consent. (c) **Law.** These Terms are governed by the law of the jurisdiction of the home office of the Omron company from which Buyer is purchasing the Products (without regard to conflict of law principles). (d) **Amendment.** These Terms constitute the entire agreement between Buyer and Omron relating to the Products, and no provision may be changed or waived unless in writing signed by the parties. (e) **Severability.** If any provision hereof is rendered ineffective or invalid, such provision shall not invalidate any other provision. (f) **Setoff.** Buyer shall have no right to set off any amounts against the amount owing in respect of this invoice. (g) **Definitions.** As used herein, "including" means "including without limitation"; and "Omron Companies" (or similar words) mean Omron Corporation and any direct or indirect subsidiary or affiliate thereof.

Certain Precautions on Specifications and Use

1. **Suitability of Use.** Omron Companies shall not be responsible for conformity with any standards, codes or regulations which apply to the combination of the Product in the Buyer's application or use of the Product. At Buyer's request, Omron will provide applicable third party certification documents identifying ratings and limitations of use which apply to the Product. This information by itself is not sufficient for a complete determination of the suitability of the Product in combination with the end product, machine, system, or other application or use. Buyer shall be solely responsible for determining appropriateness of the particular Product with respect to Buyer's application, product or system. Buyer shall take application responsibility in all cases but the following is a non-exhaustive list of applications for which particular attention must be given: (i) Outdoor use, uses involving potential chemical contamination or electrical interference, or conditions or uses not described in this document. (ii) Use in consumer products or any use in significant quantities. (iii) Energy control systems, combustion systems, railroad systems, aviation systems, medical equipment, amusement machines, vehicles, safety equipment, and installations subject to separate industry or government regulations. (iv) Systems, machines and equipment that could present a risk to life or property. Please know and observe all prohibitions of use applicable to this Product.
NEVER USE THE PRODUCT FOR AN APPLICATION INVOLVING SERIOUS RISK TO LIFE OR PROPERTY OR IN LARGE QUANTITIES WITHOUT ENSURING THAT THE SYSTEM AS A WHOLE HAS BEEN DESIGNED TO ADDRESS THE RISKS, AND THAT THE OMRON'S PRODUCT IS PROPERLY RATED AND INSTALLED FOR THE INTENDED USE WITHIN THE OVERALL EQUIPMENT OR SYSTEM.
2. **Programmable Products.** Omron Companies shall not be responsible for the user's programming of a programmable Product, or any consequence thereof.
3. **Performance Data.** Data presented in Omron Company websites, catalogs and other materials is provided as a guide for the user in determining suitability and does not constitute a warranty. It may represent the result of Omron's test conditions, and the user must correlate it to actual application requirements. Actual performance is subject to the Omron's Warranty and Limitations of Liability.
4. **Change in Specifications.** Product specifications and accessories may be changed at any time based on improvements and other reasons. It is our practice to change part numbers when published ratings or features are changed, or when significant construction changes are made. However, some specifications of the Product may be changed without any notice. When in doubt, special part numbers may be assigned to fix or establish key specifications for your application. Please consult with your Omron's representative at any time to confirm actual specifications of purchased Product.
5. **Errors and Omissions.** Information presented by Omron Companies has been checked and is believed to be accurate; however, no responsibility is assumed for clerical, typographical or proofreading errors or omissions.

OMRON

Automation...simple...powerful.

OMRON ELECTRONICS LLC • THE AMERICAS HEADQUARTERS

Schaumburg, IL USA • 847.843.7900 • 800.556.6766 • www.omron247.com

OMRON CANADA, INC. • HEAD OFFICE

Toronto, ON, Canada • 416.286.6465 • 866.986.6766 • www.omron.ca

OMRON ELETRÔNICA DO BRASIL LTDA • HEAD OFFICE

São Paulo, SP, Brasil • 55.11.2101.6300 • www.omron.com.br

OMRON ELECTRONICS MEXICO SA DE CV • HEAD OFFICE

Apodaca, N.L. • 52.811.156.99.10 • mela@omron.com

W267-E1-11

Note: Specifications are subject to change.

OMRON ARGENTINA • SALES OFFICE

Cono Sur • 54.11.4787.1129

OMRON CHILE • SALES OFFICE

Santiago 56.2206.4592

OTHER OMRON LATIN AMERICA SALES

56.2206.4592

© 2008 Omron Electronics LLC

Printed in U.S.A.