



STV9306A

Bus-Controlled Vertical Deflection System with East/West Correction Output Circuit

PRELIMINARY DATA

MAIN FEATURES

- Fully I²C controlled
- DMOS Power Half-bridge Amplifier
- DC Coupled Operation
- Internal Flyback Generator (Up to 60 V)
- Self Adapted Sawtooth (50/60 Hz)
- 100 Hz Operation
- Vertical Linearity, Amplitude and Centering Adjustments
- Horizontal Width, Pincushion, Trapezoid and Corner Adjustments
- 4:3 and 16:9 CRT Applications
- Thermal Protection
- Linear Vertical Zoom Function
- E/W Class A Output
- Few External Components

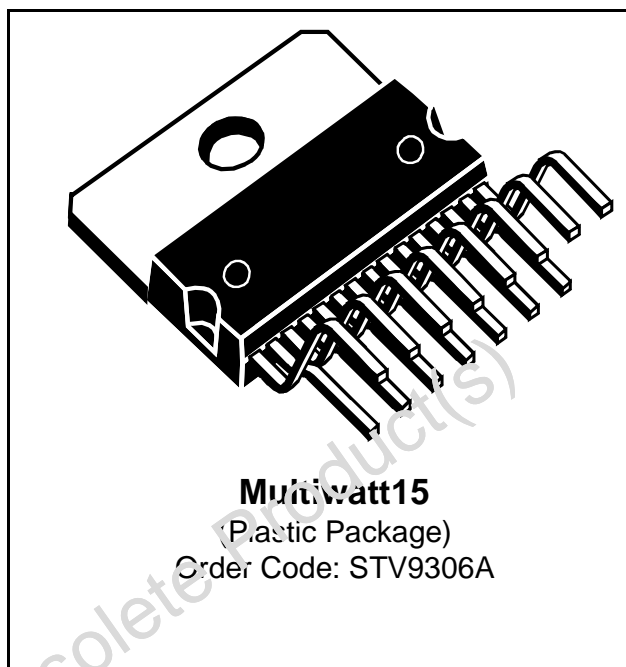

DESCRIPTION

The STV9306A is a fully I²C controlled vertical deflection IC designed for use in 110°, 4:3 or 16:9 CRT applications. It integrates both the vertical deflection and E/W correction circuits required for 110° chassis.

PRINCIPAL DIFFERENCES

	STV9306	STV9306A
E/W Output Dynamic Range	60 V	42 V
E/W Corner Correction	Positive	Positive/ Negative

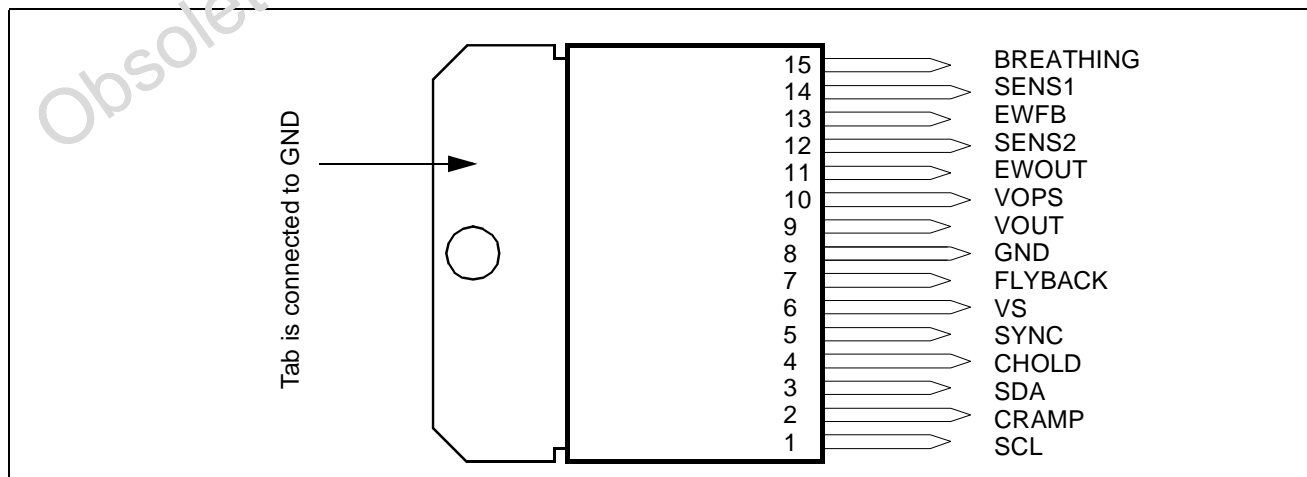

Table of Contents

Chapter 1	GENERAL DESCRIPTION	3
1.1	I/O Pin Description	3
Chapter 2	ELECTRICAL CHARACTERISTICS	4
2.1	Absolute Maximum Ratings	4
2.2	Thermal Data	4
2.3	Electrical Characteristics	4
2.4	I ² C Bus Interface	8
2.5	I ² C Bus Selection	9
Chapter 3	INPUT/OUTPUT PIN CONFIGURATION	11
Chapter 4	APPLICATION DIAGRAM	13
Chapter 5	LIST OF MODIFICATIONS	14
Chapter 6	PACKAGE DESCRIPTION	15

1 GENERAL DESCRIPTION

1.1 I/O Pin Description

Pin No.	Name	Function
1	SCL	I ² C Bus Clock
2	CRAMP	Ramp Capacitor
3	SDA	I ² C Bus Data
4	CHOLD	Hold Capacitor
5	SYNC	Sync Input
6	VS	Supply Voltage
7	FLYBACK	Flyback Output
8	GND	Ground
9	VOUT	Vertical Output
10	VOPS	Vertical Output Power Supply
11	EWOUT	E/W Output
12	SENS2	Vertical Current Sense 2
13	EWFB	E/W Feedback
14	SENS1	Vertical Current Sense 1
15	BREATHING	Breathing Input

Figure 1: STV9306A Block Diagram

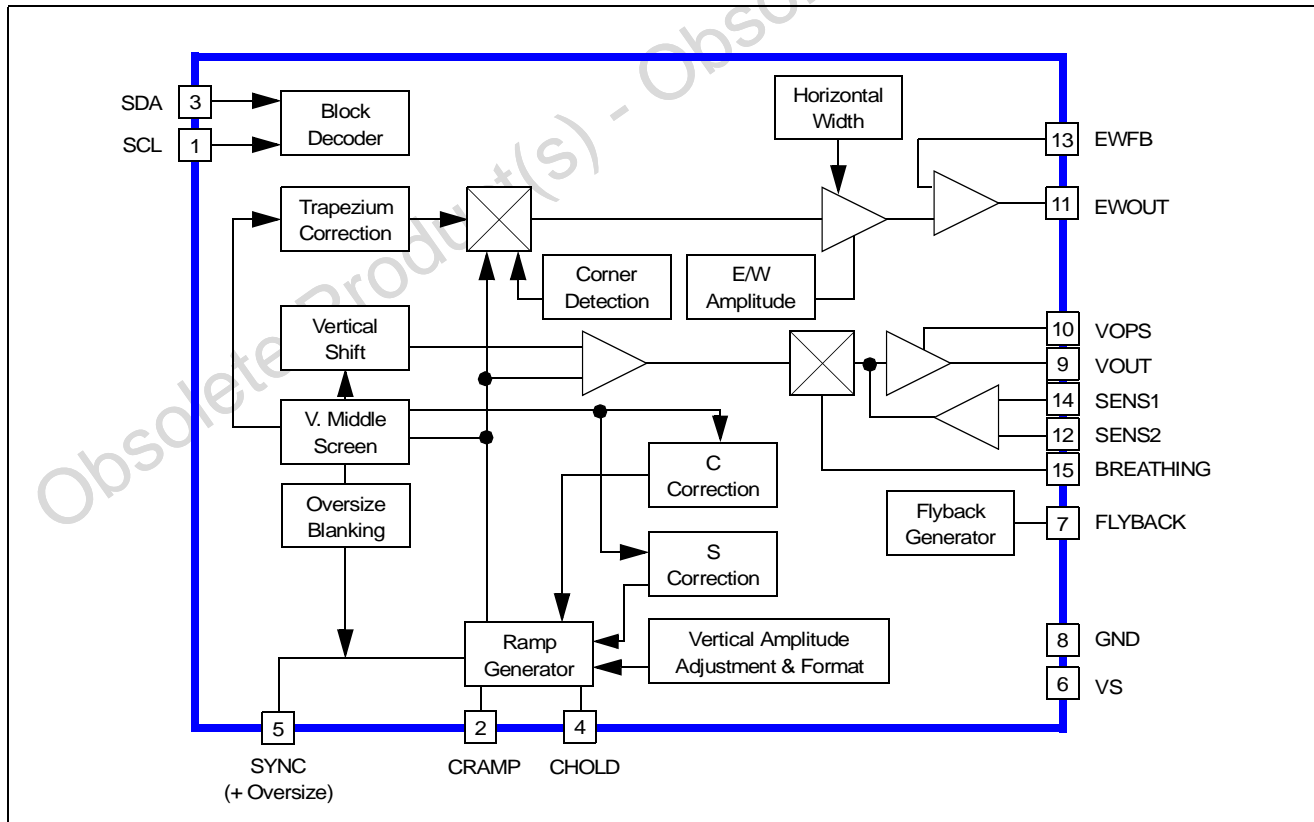

2 ELECTRICAL CHARACTERISTICS

2.1 Absolute Maximum Ratings

Symbol	Parameter	Value	Units
V_S	Supply Voltage	35	V
$V_{FLYBACK}$	Flyback Peak Voltage	60	V
V_I	Input Voltage at Pins 1-3-5-12-13-14-15	-0.3, V_S	V
V_{IS}	Input Voltage at Pins 2-4	10	V
E/W OUT	East/West Output	42	V
T_{OPER}	Operating Temperature	-10, +70	°C
T_{STG}	Storage Temperature	-55, +150	°C
T_J	Junction Temperature	+150	°C

2.2 Thermal Data

Symbol	Parameter	Value	Units
R_{thJC}	Junction-to-Case Thermal Resistance	Max. 3	°C/W
T_{TS}	Junction Temperature for Thermal Shutdown	Min. 140	°C

2.3 Electrical Characteristics

$V_S = 24$ V, $R_{SENS} = 0.5$ Ω , Normal mode, $T_{AMB} = 25^\circ$ C, unless otherwise specified.

Supply

Symbol	Parameter	Test Conditions	Min.	Typ.	Max.	Units
V_S	Operating Supply Voltage		16		28	V
I_S	Supply Current on Pins 6-10	$I_O = 0$		40	60	mA

Ramp Generator Control

Symbol	Parameter	Test Conditions	Min.	Typ.	Max.	Units
V_{Rlow}	Minimum V_{RAMP} Voltage at Pin 2		1.8	2	2.2	V
t_D	Discharge Time at Pin 2			50		μ s
I_{ISY}	Sync Input Current at Pin 5	$V_{SY} = 0$	-6	-3		μ A
V_{THSY}	Sync Threshold Voltage at Pin 5		2.5	3	3.5	V
I_{OB}	Oversize Blank Input Current at Pin 5		70	100		μ A
f_{IN}	Input Frequency Range	CRAMP = 100 nF $V_{SAW} = 100000$	40		70	Hz

Vertical Power Amplifier

Symbol	Parameter	Test Conditions	Min.	Typ.	Max.	Units
I_{IBR}	Breathing Current Input Current at Pin 15	$V_{BREATH} = 0V$	-10	-5		μA
V_{BREATH}	Breathing Operating Voltage at Pin 15		0		9	V
V_{7H}	Saturation Voltage to supply at Pin 7	$I_O = -1.5A, V_g > V_S 5V$		2.5	3.5	V
V_{7L}	Saturation Voltage to Ground at Pin 7	$I_O = 100mA$		1.5	2.5	V
I_{SENS1} I_{SENS2}	Bias Input Current at Pin 14 Bias Input Current at Pin 12	$V_{14} = 0V$ $V_{12} = 0V$	-20 -20	-10 -10		μA
V_{9H}	Saturation Voltage to supply at Pin 9 versus Pin 10	$I_O = -1.5A$		2.5	3.5	V
dV_{9H}/dT	Saturation Voltage Thermal Drift			10		mV/°C
V_{9L}	Saturation Voltage to Ground at Pin 9	$I_O = 1.5A$		1.5	2.5	V
dV_{9L}/dT	Saturation Voltage Thermal Drift			5		mV/°C

Vertical Output (Pin 9)

Symbol	Parameter	Test Conditions	Min.	Typ.	Max.	Units
I_{PP}	Vertical Deflection Peak-to-Peak Current (see Figure 2)	$V_{SAW} = 000000$ $V_{SAW} = 111111$		1.8 3.0		A
I_{DC}	Average Current (Vertical Shift) at $V_{SAW} = 111111$	$V_{SH} = 01111$ $V_{SH} = 11111$		-0.35 0.35		A
Z_{SLP}	$Z_{SLP} = \frac{\text{slope in zoom mode}}{\text{slope in normal mode}}$ See Figure 3	$V_{ZOOM} = 000$ $V_{ZOOM} = 111$		106 130		%
Unzoom	Vertical Current (Peak-to-Peak) in Unzoom mode versus Normal mode	$I_{PP}(\text{Unzoom mode})/$ $I_{PP}(\text{Normal mode})$		75		%
Subtitle	Vertical Current Shift versus Peak-to-Peak Current (Normal mode)	I_{SHIFT}/I_{PP}		$\frac{Z_{SLP} - 100}{2}$		%
I_{SC}	S Correction = I_{SC}/I_{PP} (see Figure 4)	$V_{SC} = 0000$ $V_{SC} = 1111$		0 6		%
I_{CC}	C Correction = I_{CC}/I_{PP} (see Figure 5)	$V_{CC} = 0111$ $V_{CC} = 1111$		-3 3		%
BR	Breathing $BR = \frac{I_{PP} - I_{PPB}}{I_{PP}}$ See Figure 6	$BR_{Min} \cdot V_{15} = 9V$ $BR_{Max} \cdot V_{15} = 1V$		0 10		%
R_{SENS}	Minimum External Sense Resistor		0.5			Ohm

East/West Correction(V_SAW = 100000, V_SH = 10000, V_SC = 0000, V_CC = 1000) (see [Figure 7](#))

Symbol	Parameter	Test Conditions	Min.	Typ.	Max.	Units
I _{BIAS}	Input Bias Current at Pin 13		-1	-0.5		μA
V _{PAR}	Parabola Amplitude (Pincushion Correction) at Pin 13 (see Figure 8)	EW_AMP = 00000 EW_AMP = 11111		0 5		V V
V _{DCEW}	Horizontal Width Adjustment at Pin 13 (see Figure 9)	EW_DC = 00000 EW_DC = 11111 HShrink active		1 6 +5.5		V
Trap	Trapezium Correction at Pin 13 Trap = V _{PARTUP} /V _{PARTLOW} (see Figure 10)	EW_TRAP = 01111 EW_TRAP = 11111		0.6 1.7		
Corner	Parabola Corner Correction at Pin 13 (see Figure 11) Corner = V _{COR} /V _{PAR}	EW_CORNER = 00000 EW_CORNER = 11111		0 60		%
No Corner	EW_CORNER Code for Parabola with No Corner Correction			0 1111		Binary Code
V _{11L}	Saturation Voltage	I _{OUT} = 500 mA			2	V
I _{MAX}	E/W Sink Average Current				0.5	A

Figure 2: Vertical Amplitude and Position

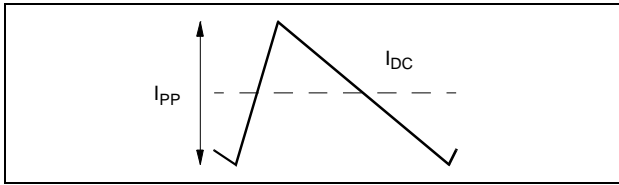

Figure 3: Zoom Mode

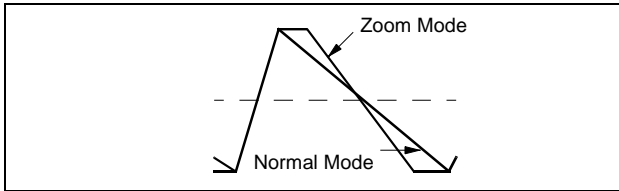

Figure 4: S Correction

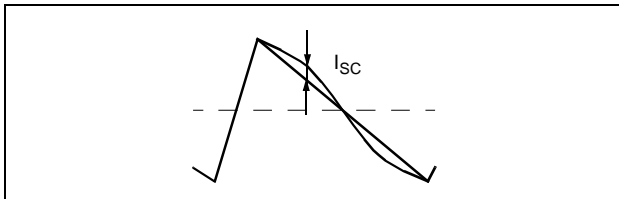

Figure 5: C Correction

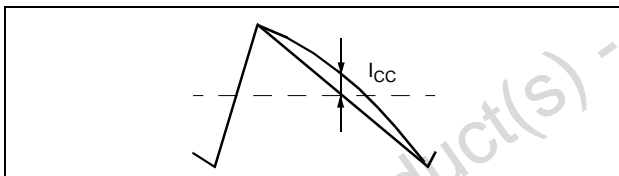

Figure 6: Breathing Correction

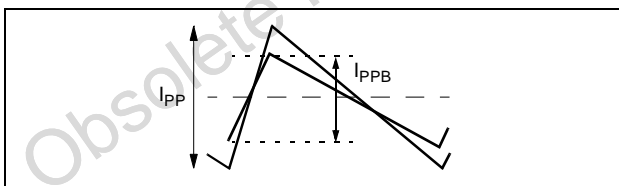

Figure 7: E/W Output

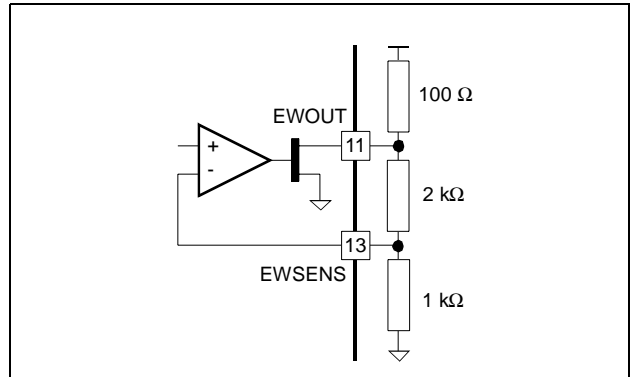

Figure 8: Pincushion Correction

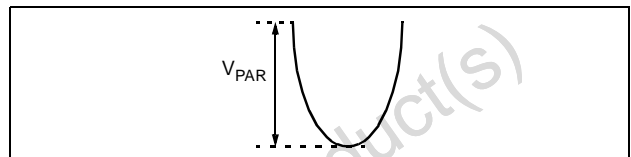

Figure 9: Horizontal Width Adjustment

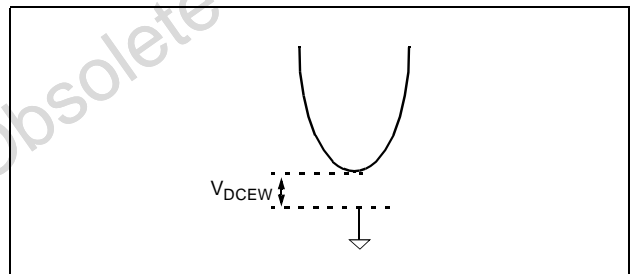

Figure 10: Trapezium Correction

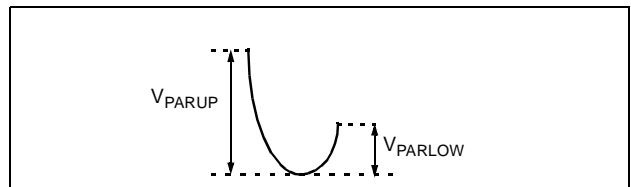
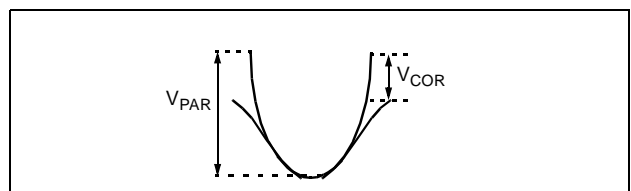

Figure 11: Corner Correction



2.4 I²C Bus Interface

Symbol	Parameter	Test Conditions	Min.	Typ.	Max.	Units
SCL (Pin 1)						
V _{IL}	Low Level Input Voltage		-0.3		1.5	V
V _{IH}	High Level Input Voltage		3.0		5.5	V
I _{LI}	Input Leakage Current	V _{IN} = 0 to 5V	-10		10	μA
f _{SCL}	Clock Frequency		0		100	kHz
t _R	Input Rise Time	1.5V to 3V			1000	ns
t _F	Input Fall Time	1.5V to 3V			300	ns
C _I	Input Capacitance				10	pF
SDA (Pin 3)						
V _{IL}	Low Level Input Voltage		-0.3		1.5	V
V _{IH}	High Level Input Voltage		3.0		5.5	V
I _{LI}	Input Leakage Current	V _{IN} = 0 to 5V	-10		10	μA
C _I	Input Capacitance				10	pF
t _R	Input Rise Time	1.5V to 3V			1000	ns
t _F	Input Fall Time	1.5V to 3V			300	ns
V _{OL}	Low Level Output Voltage	I _{OL} = 3mA			0.4	V
t _F	Output Fall Time	3V to 1.5V			250	ns
C _L	Load Capacitance				400	pF
Timing						
t _{LOW}	Clock Low Period		4.7			μs
t _{HIGH}	Clock High Period		4.0			μs
t _{SU, DAT}	Data Set-up Time		250			ns
t _{HD, DAT}	Data Hold Time		0		340	ns
t _{SU, STO}	Set-up Time from Clock High to Stop		4.0			μs
t _{BUF}	Start Set-up Time following a Stop		4.7			μs
t _{HD, STA}	Start Hold Time		4.0			μs
t _{SU, STA}	Start Set-up Time following Clock Low-to High Transition		4.7			μs

Figure 12: Serial Bus Timing

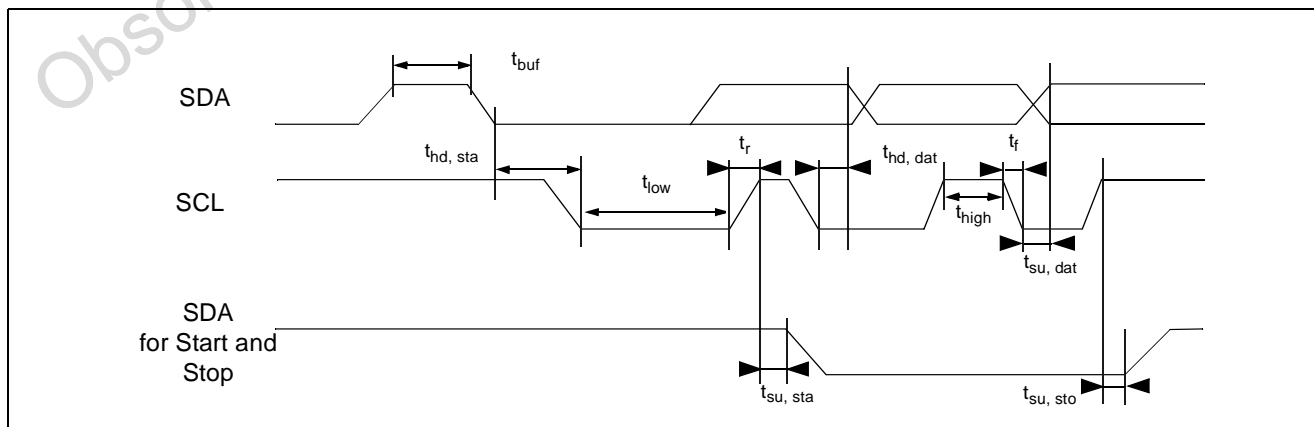

2.5 I²C Bus Selection

2.5.1 Write Mode: Slave Address: 1000 1100 (8C)

Subaddress								Data								
B7	B6	B5	B4	B3	B2	B1	B0	B7	B6	B5	B4	B3	B2	B1	B0	
0	0	0	X	X	X	X	0	Vertical Amplitude							X	1
0	0	1	X	X	X	X	0	Sign	Vertical Shift				X	X	1	
0	1	0	X	X	X	X	0	S. Correction			Zoom Mode			Subtitle	1	
0	1	1	X	X	X	X	0	Sign	C. Correction		Zoom Amplitude				1	
1	0	0	X	X	X	X	0	Horizontal Width					Hshr	X	1	
1	0	1	X	X	X	X	0	E/w Correction					X	X	1	
1	1	0	X	X	X	X	0	E/w Corner Correction					Ext. Transistor	X	1	
1	1	1	X	X	X	X	0	Sign	Trap. Correction				HiZ	X	1	

Data

B7	B6	B5	B4	B3	B2	B1	B0	
Vertical Amplitude (V_SAW)								
0	0	0	0	0	0	X	1	Min. Amplitude
1	1	1	1	1	1	X	1	Max. Amplitude
Vertical Shift (V_SH)								
X	0	0	0	0	X	X	1	Min. Shift Level
X	1	1	1	1	X	X	1	Max. Shift Level
1	X	X	X	X	X	X	1	Positive Shift
0	X	X	X	X	X	X	1	Negative Shift
S Correction (V_SC) & Zoom Position								
0	0	0	0	X	X	X	1	Min. S Correction
1	1	1	1	X	X	X	1	Max. S Correction
X	X	X	X	0	0	X	1	Normal Mode
X	X	X	X	0	1	X	1	Unzoom
X	X	X	X	1	X	X	1	Zoom
X	X	X	X	X	X	0	1	Subtitle Disabled
X	X	X	X	X	X	1	1	Subtitle Enabled
C Correction (V_CC) & Progressive Zoom (V_ZOOM)								
1	X	X	X	X	X	X	1	Positive C Correction
0	X	X	X	X	X	X	1	Negative C Correction
X	0	0	0	X	X	X	1	Min. C Correction
X	1	1	1	X	X	X	1	Max. C Correction
X	X	X	X	0	0	0	1	Min. Zoom Magnitude
X	X	X	X	1	1	1	1	Max. Zoom Magnitude
Horizontal Width Adjustment (EW_VDC)								
0	0	0	0	0	X	X	1	Hwidth Min. Level
1	1	1	1	1	X	X	1	Hwidth Max. Level
X	X	X	X	X	0	X	1	Hwidth Shrink Disabled
X	X	X	X	X	1	X	1	Hwidth Shrink Enabled

B7	B6	B5	B4	B3	B2	B1	B0	
Pincushion Correction (EW_AMP)								
0	0	0	0	0	X	X	1	Min. Amplitude
1	1	1	1	1	X	X	1	Max. Amplitude
E/W Corner (EW_CORNER)								
0	0	0	0	0	X	X	1	Min. Corner Correction
1	1	1	1	1	X	X	1	Max. Corner Correction
X	X	X	X	X	1	X	1	External E/W Transistor
X	X	X	X	X	0	X	1	Internal E/W Transistor
Trapezium Correction (EW_TRAP) & High Impedance								
1	X	X	X	X	X	X	1	Positive Trapezium Correction
0	X	X	X	X	X	X	1	Negative Trapezium Correction
X	0	0	0	0	X	X	1	Min. Level Correction
X	1	1	1	1	X	X	1	Max. Level Correction
X	X	X	X	X	0	X	1	Normal Mode
X	X	X	X	X	1	X	1	High Impedance Mode

2.5.2 Read Mode: Slave Address: 1000 1101 (8D)

Data

B7	B6	B5	B4	B3	B2	B1	B0	
Thermal Security Status								
0	X	X	X	X	X	X	1	Normal Temperature
1	X	X	X	X	X	X	1	Thermal Security Active
Flyback Pulse Detection Status								
X	0	X	X	X	X	X	1	Flyback Pulse detected
X	1	X	X	X	X	X	1	Lack of Flyback Pulse
Sync Pulse Detection Status								
X	X	0	X	X	X	X	1	Sync Pulse Present
X	X	1	X	X	X	X	1	Lack of Sync Pulse

3 INPUT/OUTPUT PIN CONFIGURATION

Figure 13: I²C Bus Clock

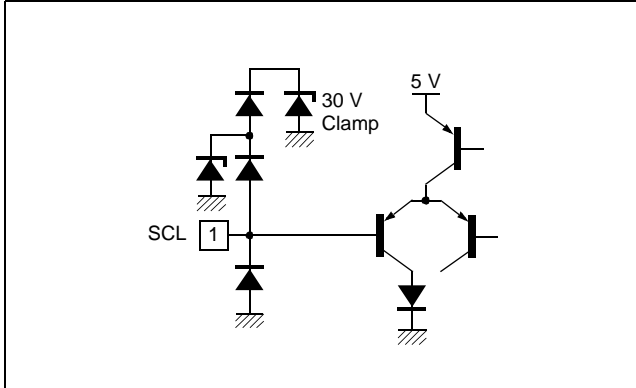

Figure 16: Hold Capacitor

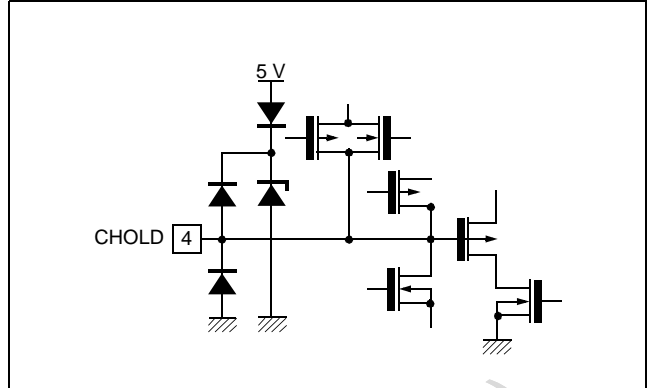

Figure 14: Ramp Capacitor

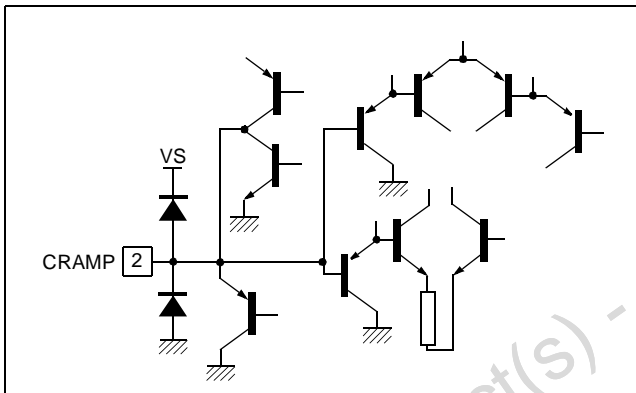

Figure 17: Sync Input

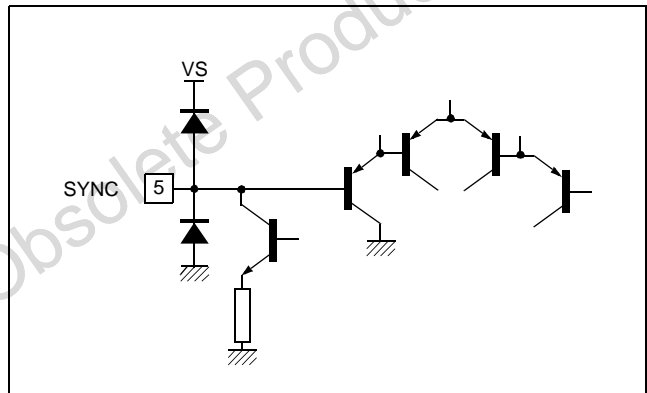

Figure 15: I²C Bus Data

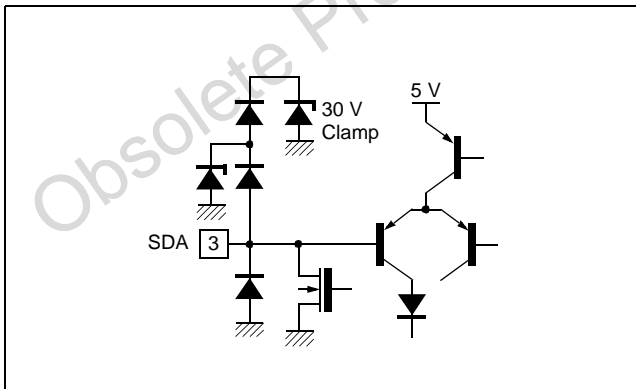

Figure 18: Flyback Output

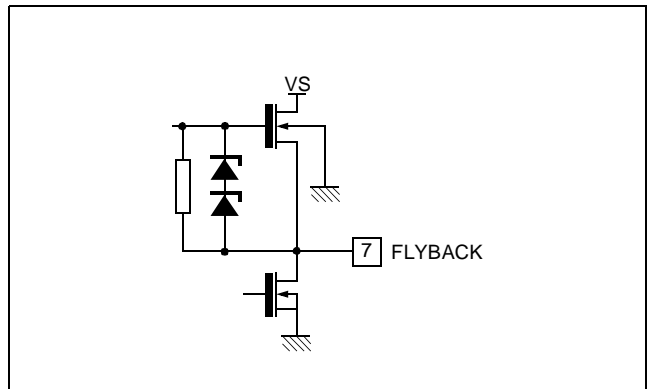

Figure 19: Vertical Output

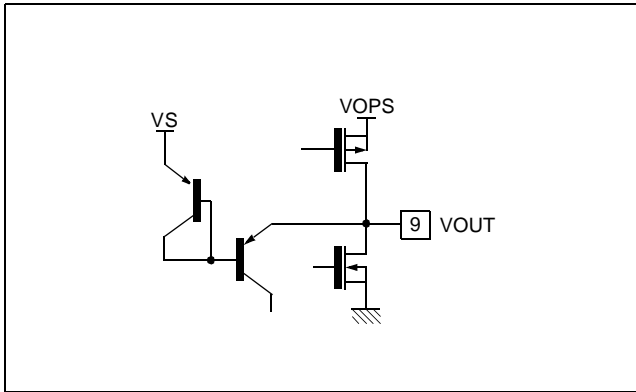

Figure 22: Vertical Current Sense

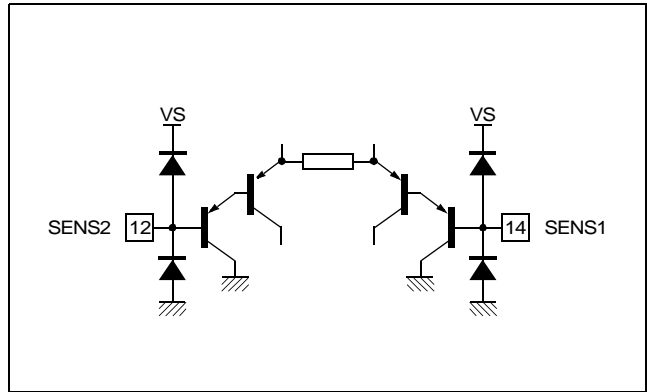

Figure 20: Vertical Output Power Supply

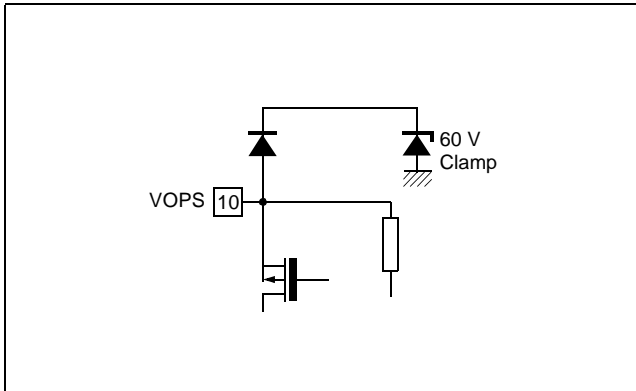

Figure 23: E/W Feedback

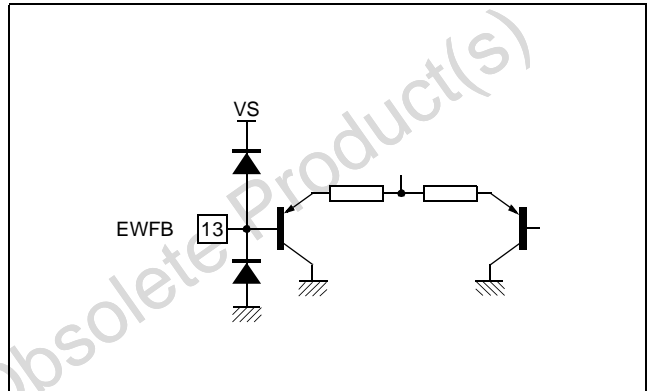

Figure 21: E/W Output

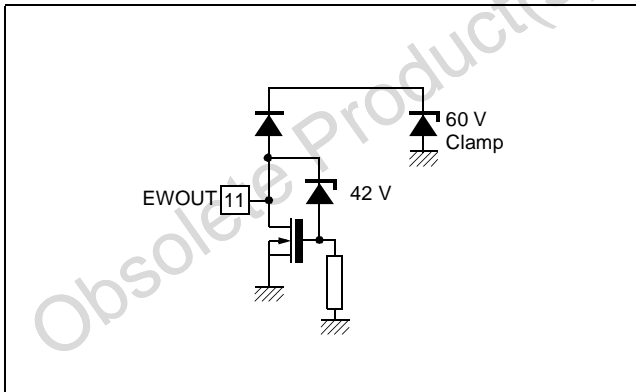
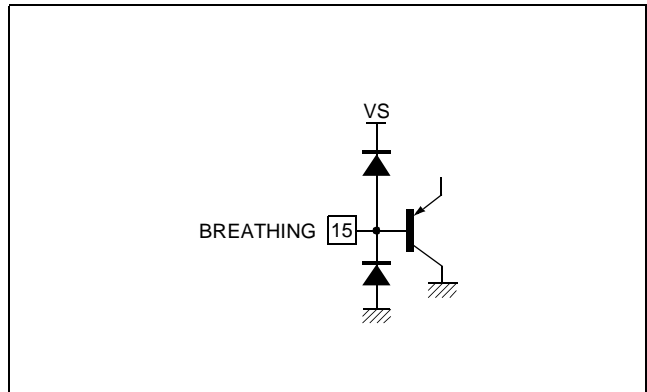
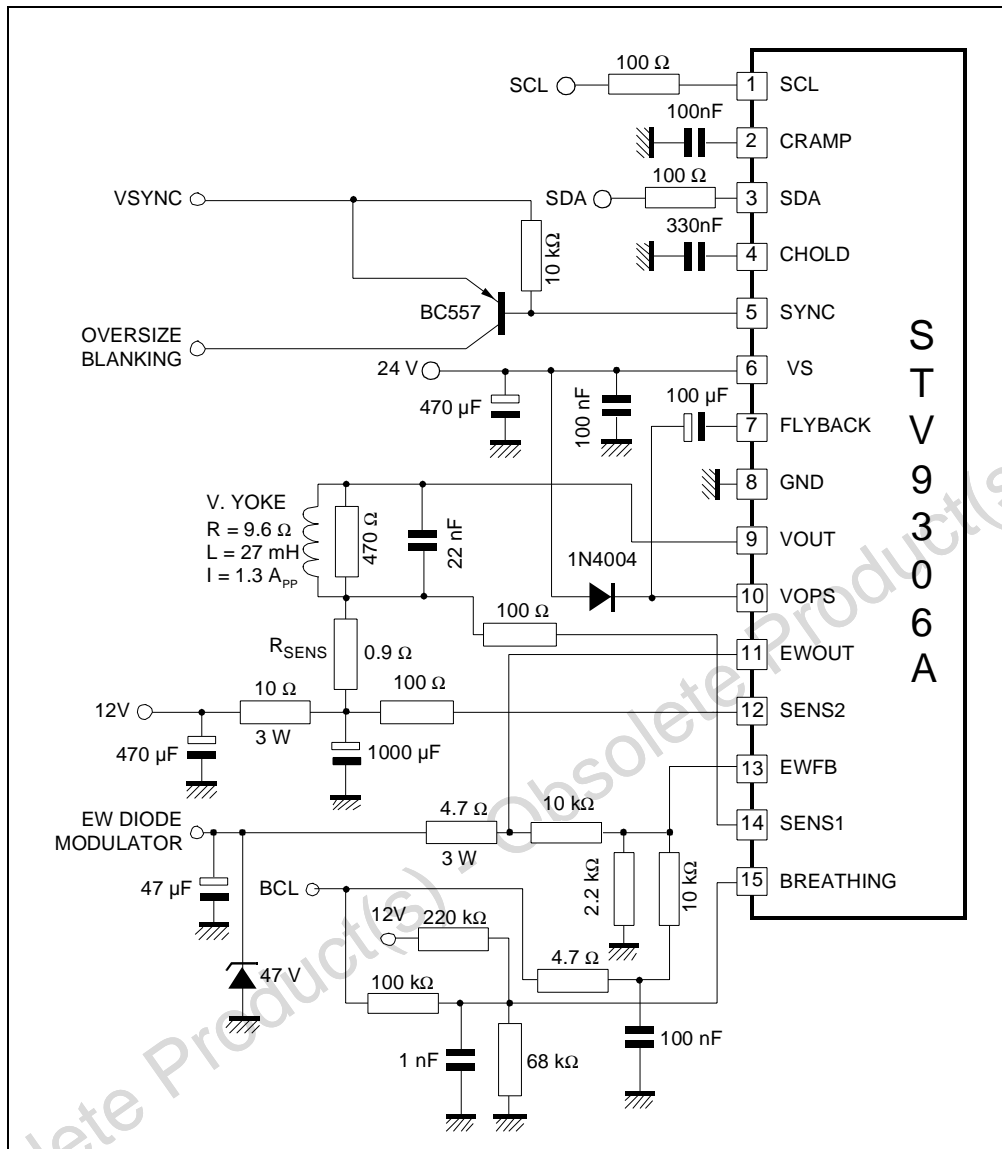

Figure 24: Breathing Input



4 APPLICATION DIAGRAM

Figure 25: STV9306A Application Diagram



5 LIST OF MODIFICATIONS

Revision	Modification	Date
1.0	First Issue	Sept. 2001
1.1	Modification of No Corner value in table East/West Correction on page 6 . Document upgraded to Preliminary Data datsheet.	Nov. 2001
1.2	Modification of Vertical Output (Pin 9) on page 5 and V_{DCEW} Value in East/West Correction on page 6 .	March 2002

Obsolete Product(s) - Obsolete Product(s)

6 PACKAGE DESCRIPTION

Figure 26: 15-Pin Plastic Multiwatt Package

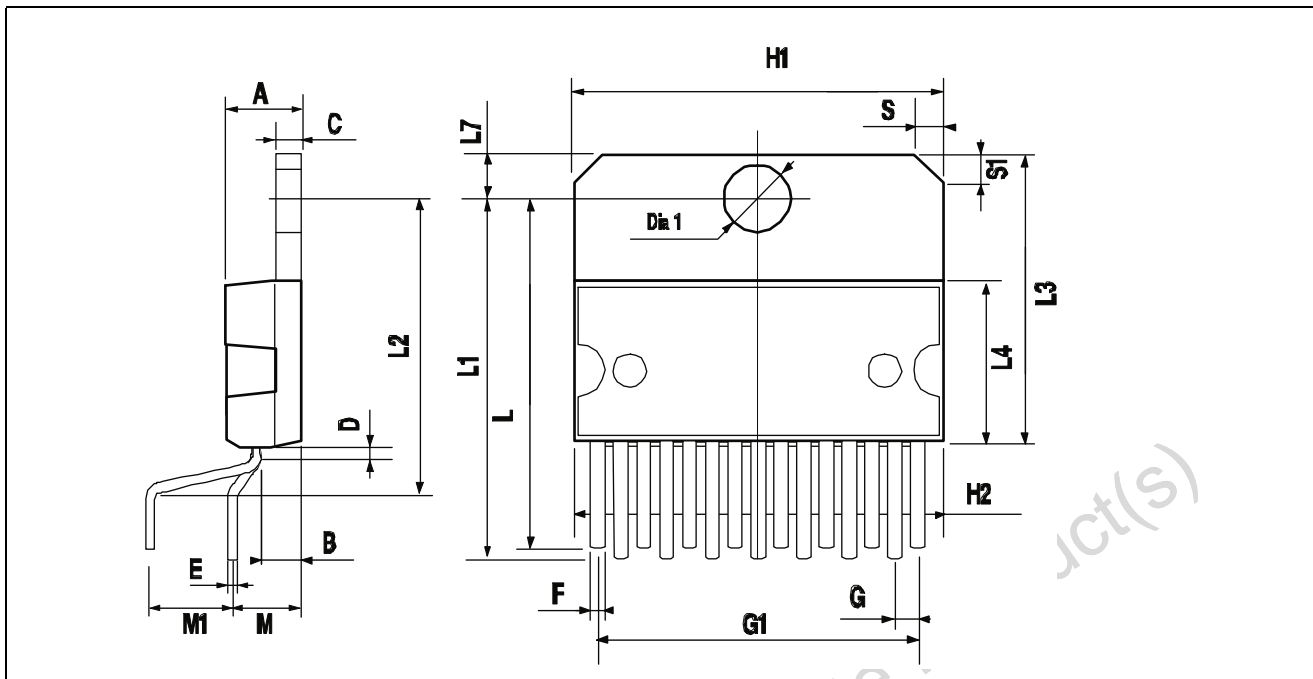

Dimension	Millimeters			Inches		
	Min.	Typ.	Max.	Min.	Typ.	Max.
A			5			0.197
B			2.65			0.104
C			1.6			0.063
D		1			0.039	
E	0.49		0.55	0.019		0.022
F	0.66		0.75	0.026		0.030
G	1.02	1.27	1.52	0.040	0.050	0.060
G1	17.53	17.78	18.03	0.690	0.700	0.710
H1	19.60			0.772		
H2			20.2			0.795
L	21.9	22.2	22.5	0.862	0.874	0.886
L1	21.7	22.1	22.5	0.854	0.870	0.886
L2	17.65		18.1	0.695		0.713
L3	17.25	17.50	17.75	0.679	0.689	0.699
L4	10.3	10.7	10.9	0.406	0.421	0.429
L7	2.65		2.9	0.104		0.114
M	4.25	4.55	4.85	0.167	0.179	0.191
M1	4.63	5.08	5.53	0.182	0.200	0.218
S	1.9		2.6	0.075		0.102
S1	1.9		2.6	0.075		0.102
Dia1	3.65		3.85	0.144		0.152

Information furnished is believed to be accurate and reliable. However, STMicroelectronics assumes no responsibility for the consequences of use of such information nor for any infringement of patents or other rights of third parties which may result from its use. No license is granted by implication or otherwise under any patent or patent rights of STMicroelectronics. Specifications mentioned in this publication are subject to change without notice. This publication supersedes and replaces all information previously supplied. STMicroelectronics products are not authorized for use as critical components in life support devices or systems without express written approval of STMicroelectronics.

The ST logo is a registered trademark of STMicroelectronics

© 2003 STMicroelectronics - All Rights Reserved

STMicroelectronics GROUP OF COMPANIES

Australia - Brazil - Canada - China - Finland - France - Germany - Hong Kong - India - Israel - Italy - Japan
Malaysia - Malta - Morocco - Singapore - Spain - Sweden - Switzerland - United Kingdom - U.S.A.

www.st.com