



# STB57N65M5, STF57N65M5, STI57N65M5, STP57N65M5

N-channel 650 V, 0.056  $\Omega$  typ., 42 A MDmesh™ V Power MOSFET in I<sup>2</sup>PAK, TO-220, TO-220FP and D<sup>2</sup>PAK packages

Datasheet — production data

## Features

Order codes	V <sub>DSS</sub> @ T <sub>Jmax</sub>	R <sub>DS(on)</sub> max	I <sub>D</sub>
STB57N65M5 STF57N65M5 STI57N65M5 STP57N65M5	710 V	< 0.063 $\Omega$	42 A

- Worldwide best R<sub>DS(on)</sub>\* area amongst the silicon based devices
- Higher V<sub>DSS</sub> rating, high dv/dt capability
- Excellent switching performance
- Easy to drive, 100% avalanche tested

## Applications

- Switching applications

## Description

These devices are N-channel MDmesh™ V Power MOSFETs based on an innovative proprietary process technology, which is combined with STMicroelectronics' well-known PowerMESH™ horizontal layout structure. The resulting product has extremely low on-resistance, which is unmatched among silicon-based Power MOSFETs, making it especially suitable for applications which require superior power density and outstanding efficiency.

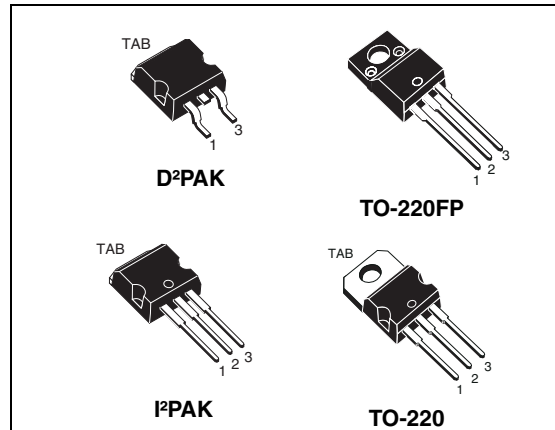
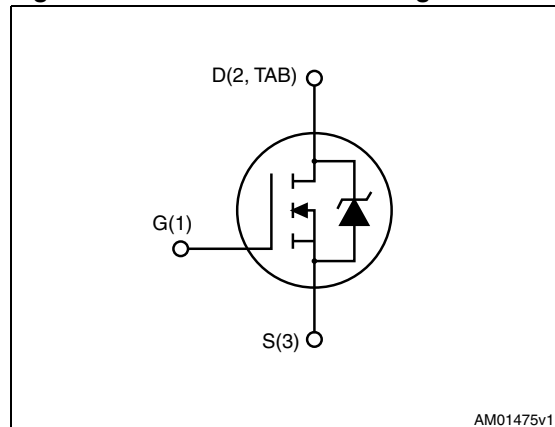

Figure 1. Internal schematic diagram



AM01475v1

Table 1. Device summary

Order codes	Marking	Packages	Packaging
STB57N65M5 STF57N65M5 STI57N65M5 STP57N65M5	57N65M5	D <sup>2</sup> PAK TO-220FP I <sup>2</sup> PAK TO-220	Tape and reel Tube Tube Tube

## Contents

<b>1</b>	<b>Electrical ratings</b> .....	<b>3</b>
<b>2</b>	<b>Electrical characteristics</b> .....	<b>4</b>
	2.1 Electrical characteristics (curves) .....	6
<b>3</b>	<b>Test circuits</b> .....	<b>9</b>
<b>4</b>	<b>Package mechanical data</b> .....	<b>10</b>
<b>5</b>	<b>Packaging mechanical data</b> .....	<b>22</b>
<b>6</b>	<b>Revision history</b> .....	<b>24</b>

# 1 Electrical ratings

**Table 2. Absolute maximum ratings**

Symbol	Parameter	Value		Unit
		TO-220, D <sup>2</sup> PAK, I <sup>2</sup> PAK	TO-220FP	
V <sub>GS</sub>	Gate- source voltage	± 25		V
I <sub>D</sub>	Drain current (continuous) at T <sub>C</sub> = 25 °C	42	42 <sup>(1)</sup>	A
I <sub>D</sub>	Drain current (continuous) at T <sub>C</sub> = 100 °C	26.5	26.5 <sup>(1)</sup>	A
I <sub>DM</sub> <sup>(2)</sup>	Drain current (pulsed)	168	168 <sup>(1)</sup>	A
P <sub>TOT</sub>	Total dissipation at T <sub>C</sub> = 25 °C	250	40	W
I <sub>AR</sub>	Max current during repetitive or single pulse avalanche (pulse width limited by T <sub>JMAX</sub> )	11		A
E <sub>AS</sub>	Single pulse avalanche energy (starting T <sub>J</sub> = 25°C, I <sub>D</sub> = I <sub>AR</sub> , V <sub>DD</sub> = 50V)	960		mJ
dv/dt <sup>(3)</sup>	Peak diode recovery voltage slope	15		V/ns
V <sub>ISO</sub>	Insulation withstand voltage (RMS) from all three leads to external heat sink (t = 1 s; T <sub>C</sub> = 25 °C)	2500		V
T <sub>stg</sub>	Storage temperature	-55 to 150		°C
T <sub>j</sub>	Max. operating junction temperature	150		°C

1. Limited by maximum junction temperature.

2. Pulse width limited by safe operating area.

3. I<sub>SD</sub> ≤ 42 A, di/dt ≤ 400 A/μs, V<sub>Peak</sub> < V<sub>(BR)DSS</sub>, V<sub>DD</sub> = 400 V

**Table 3. Thermal data**

Symbol	Parameter	Value				Unit
		D <sup>2</sup> PAK	I <sup>2</sup> PAK	TO-220	TO-220FP	
R <sub>thj-case</sub>	Thermal resistance junction-case max	0.50		3.1		°C/W
R <sub>thj-amb</sub>	Thermal resistance junction-ambient max	62.5		62.5		°C/W
R <sub>thj-pcb</sub>	Thermal resistance junction-pcb max <sup>(1)</sup>	30				°C/W

1. When mounted on 1inch<sup>2</sup> FR-4 board, 2 oz Cu.

## 2 Electrical characteristics

( $T_C = 25\text{ °C}$  unless otherwise specified)

**Table 4. On /off states**

Symbol	Parameter	Test conditions	Min.	Typ.	Max.	Unit
$V_{(BR)DSS}$	Drain-source breakdown voltage	$I_D = 1\text{ mA}$ , $V_{GS} = 0$	650			V
$I_{DSS}$	Zero gate voltage drain current ( $V_{GS} = 0$ )	$V_{DS} = 650\text{ V}$ $V_{DS} = 650\text{ V}$ , $T_C = 125\text{ °C}$			1 100	$\mu\text{A}$ $\mu\text{A}$
$I_{GSS}$	Gate-body leakage current ( $V_{DS} = 0$ )	$V_{GS} = \pm 25\text{ V}$			$\pm 100$	nA
$V_{GS(th)}$	Gate threshold voltage	$V_{DS} = V_{GS}$ , $I_D = 250\text{ }\mu\text{A}$	3	4	5	V
$R_{DS(on)}$	Static drain-source on-resistance	$V_{GS} = 10\text{ V}$ , $I_D = 21\text{ A}$		0.056	0.063	$\Omega$

**Table 5. Dynamic**

Symbol	Parameter	Test conditions	Min.	Typ.	Max.	Unit
$C_{iss}$	Input capacitance	$V_{DS} = 100\text{ V}$ , $f = 1\text{ MHz}$ , $V_{GS} = 0$	-	4200	-	pF
$C_{oss}$	Output capacitance			115		pF
$C_{rss}$	Reverse transfer capacitance			9		pF
$C_{o(er)}^{(1)}$	Equivalent output capacitance energy related	$V_{GS} = 0$ , $V_{DS} = 0$ to 80% $V_{(BR)DSS}$	-	93	-	pF
$C_{o(tr)}^{(2)}$	Equivalent output capacitance time related	$V_{GS} = 0$ , $V_{DS} = 0$ to 80% $V_{(BR)DSS}$	-	303	-	pF
$R_G$	Intrinsic gate resistance	$f = 1\text{ MHz}$ open drain	-	1.3	-	$\Omega$
$Q_g$	Total gate charge	$V_{DD} = 520\text{ V}$ , $I_D = 21\text{ A}$ , $V_{GS} = 10\text{ V}$ (see <a href="#">Figure 18</a> )	-	98	-	nC
$Q_{gs}$	Gate-source charge			23		nC
$Q_{gd}$	Gate-drain charge			40		nC

- $C_{o(er)}^{(1)}$  is a constant capacitance value that gives the same stored energy as  $C_{oss}$  while  $V_{DS}$  is rising from 0 to 80%  $V_{DSS}$
- $C_{o(tr)}^{(2)}$  is a constant capacitance value that gives the same charging time as  $C_{oss}$  while  $V_{DS}$  is rising from 0 to 80%  $V_{DSS}$

Table 6. Switching times

Symbol	Parameter	Test conditions	Min.	Typ.	Max.	Unit
$t_{d(V)}$	Voltage delay time	$V_{DD} = 400\text{ V}$ , $I_D = 28\text{ A}$ , $R_G = 4.7\ \Omega$ , $V_{GS} = 10\text{ V}$ (see <a href="#">Figure 19</a> )		73		ns
$t_{r(V)}$	Voltage rise time		-	15	-	ns
$t_{f(i)}$	Current fall time				12	ns
$t_{c(off)}$	Crossing time				19	ns

Table 7. Source drain diode

Symbol	Parameter	Test conditions	Min.	Typ.	Max.	Unit
$I_{SD}$	Source-drain current		-		42	A
$I_{SDM}^{(1)}$	Source-drain current (pulsed)				168	A
$V_{SD}^{(2)}$	Forward on voltage	$I_{SD} = 42\text{ A}$ , $V_{GS} = 0$	-		1.5	V
$t_{rr}$	Reverse recovery time	$I_{SD} = 42\text{ A}$ , $di/dt = 100\text{ A}/\mu\text{s}$ $V_{DD} = 100\text{ V}$ (see <a href="#">Figure 19</a> )	-	418		ns
$Q_{rr}$	Reverse recovery charge			8		$\mu\text{C}$
$I_{RRM}$	Reverse recovery current			40		A
$t_{rr}$	Reverse recovery time	$I_{SD} = 42\text{ A}$ , $di/dt = 100\text{ A}/\mu\text{s}$ $V_{DD} = 100\text{ V}$ , $T_j = 150\text{ }^\circ\text{C}$ (see <a href="#">Figure 19</a> )	-	528		ns
$Q_{rr}$	Reverse recovery charge			12		$\mu\text{C}$
$I_{RRM}$	Reverse recovery current			44		A

1. Pulse width limited by safe operating area
2. Pulsed: pulse duration = 300  $\mu\text{s}$ , duty cycle 1.5%

## 2.1 Electrical characteristics (curves)

Figure 2. Safe operating area for D<sup>2</sup>PAK, I<sup>2</sup>PAK and TO-220

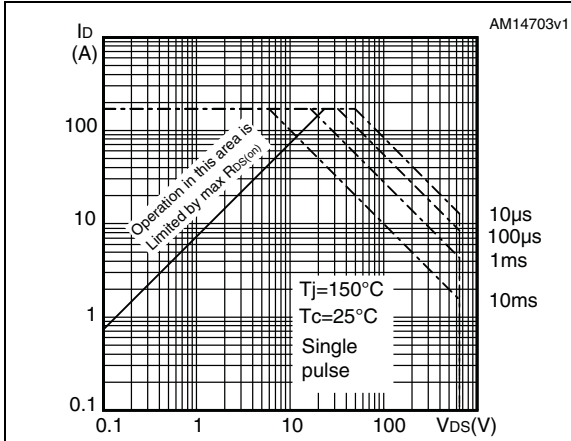

Figure 3. Thermal impedance for D<sup>2</sup>PAK, I<sup>2</sup>PAK and TO-220

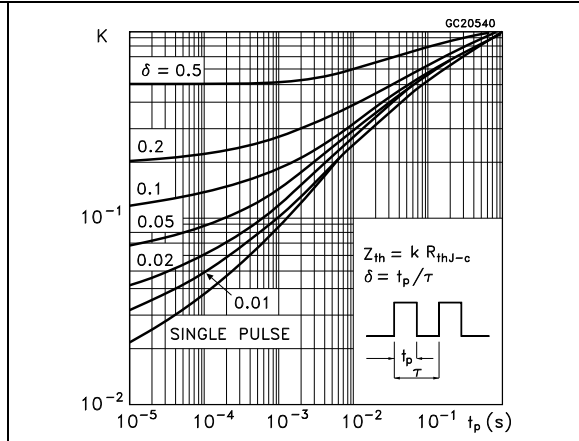

Figure 4. Safe operating area for TO-220FP

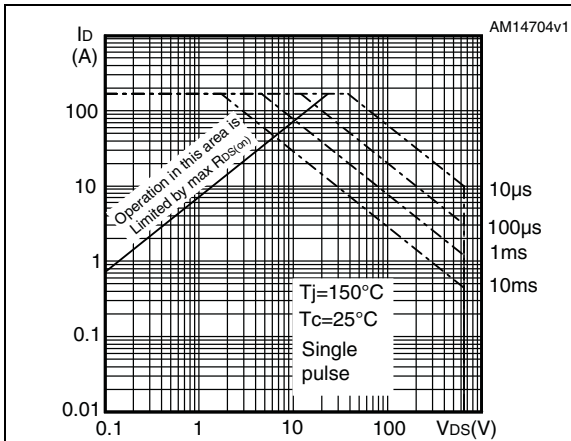

Figure 5. Thermal impedance for TO-220FP

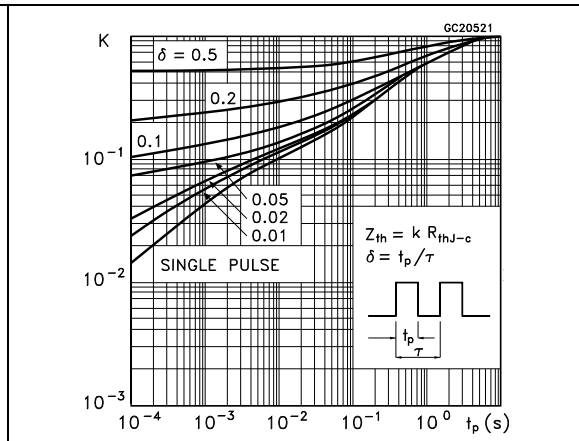

Figure 6. Output characteristics

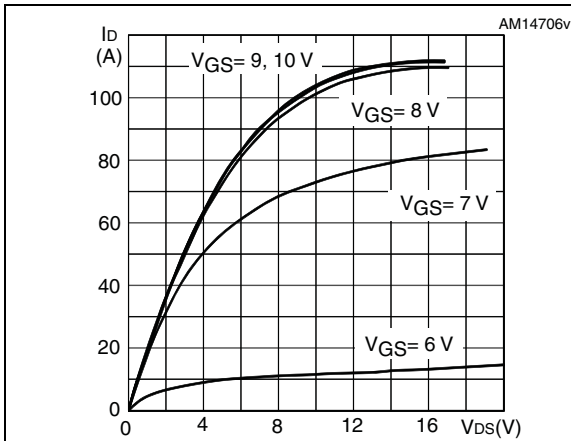

Figure 7. Transfer characteristics

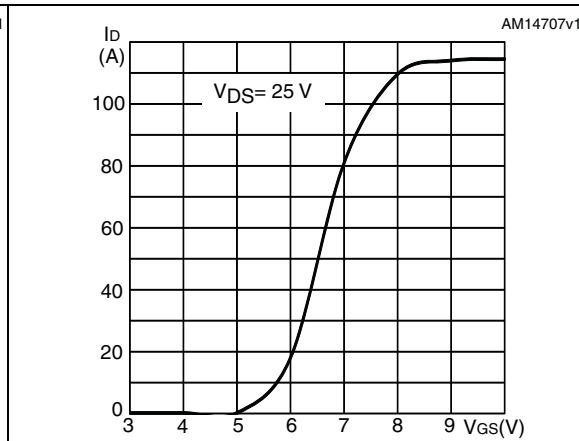

Figure 8. Gate charge vs gate-source voltage Figure 9. Static drain-source on-resistance

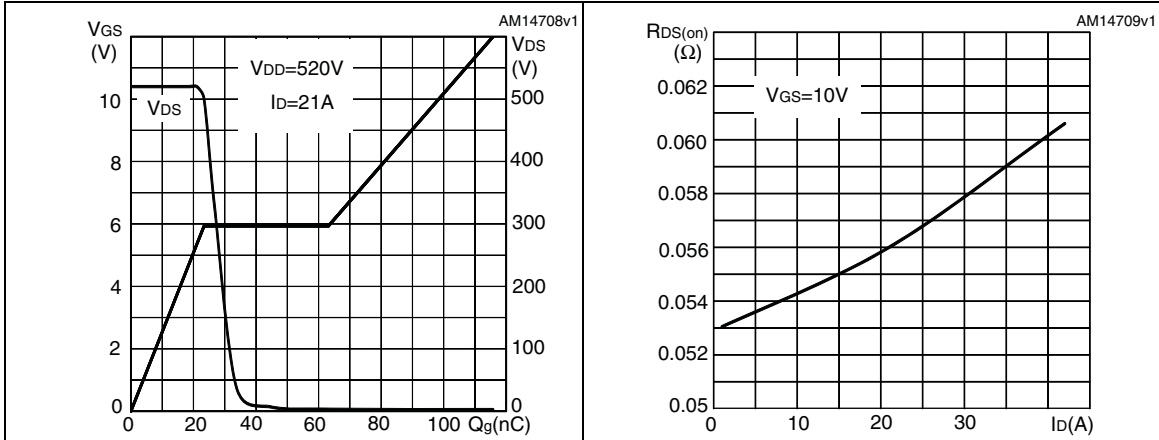

Figure 10. Capacitance variations Figure 11. Output capacitance stored energy

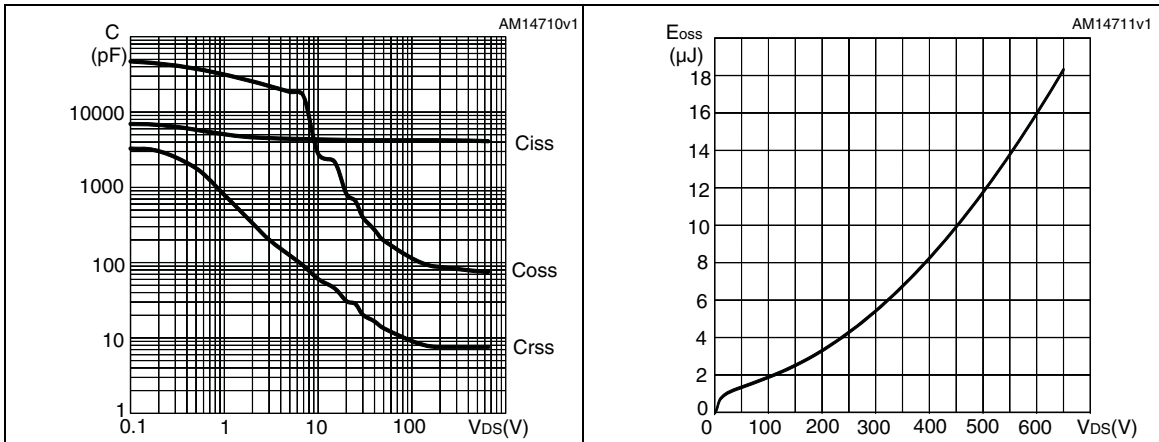

Figure 12. Normalized gate threshold voltage vs temperature Figure 13. Normalized on-resistance vs temperature

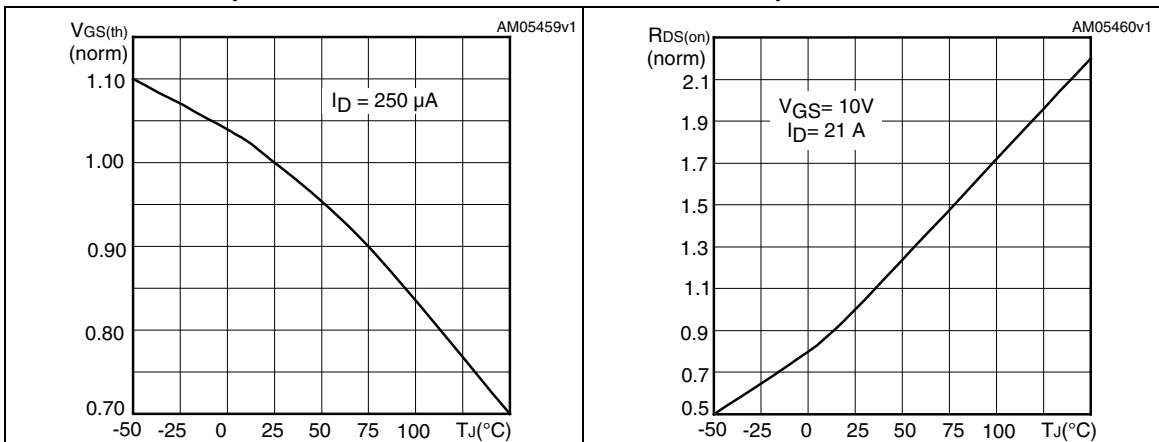

Figure 14. Source-drain diode forward characteristics

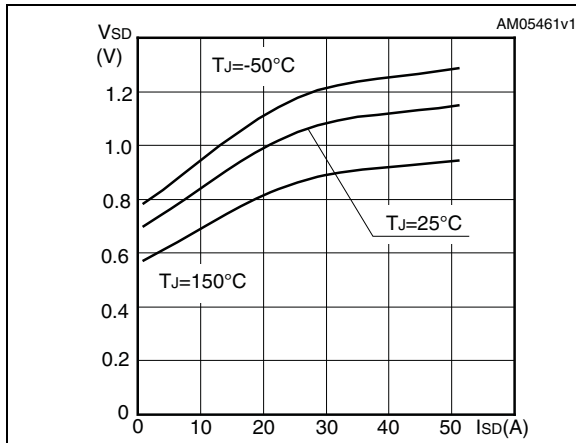

Figure 15. Normalized B<sub>V</sub>DSS vs temperature

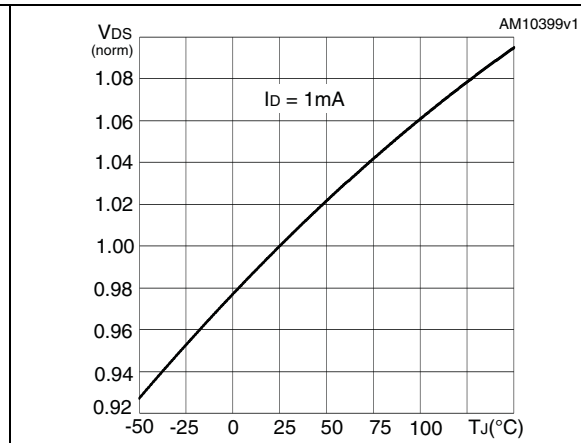
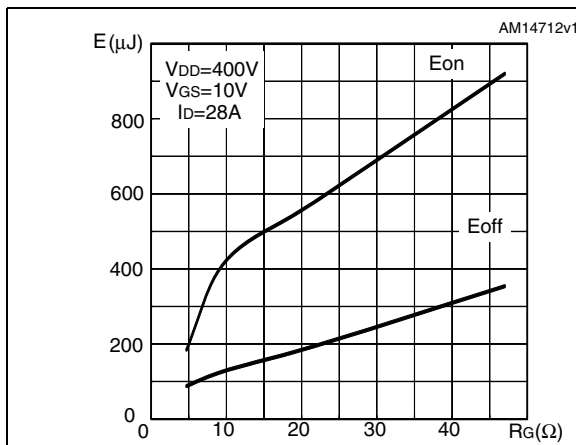

Figure 16. Switching losses vs gate resistance (1)



1. E<sub>on</sub> including reverse recovery of a SiC diode



### 3 Test circuits

Figure 17. Switching times test circuit for resistive load

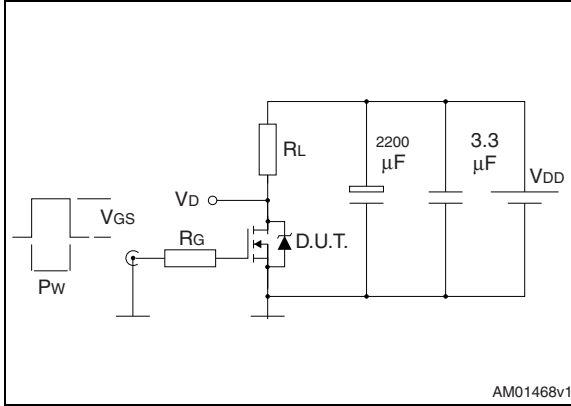

Figure 18. Gate charge test circuit

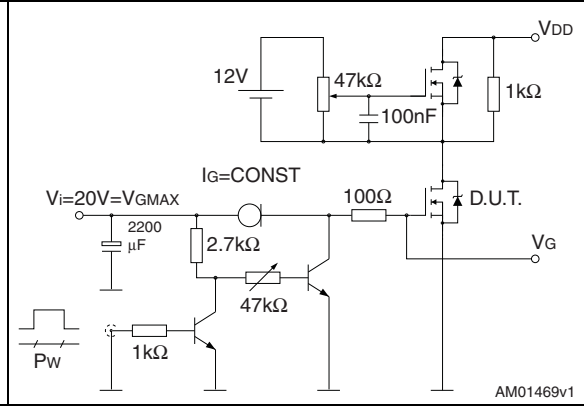

Figure 19. Test circuit for inductive load switching and diode recovery times

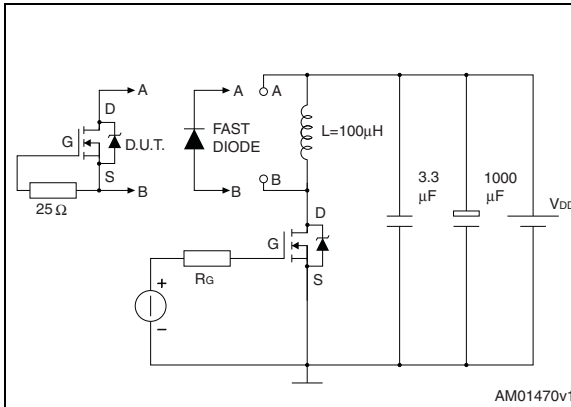

Figure 20. Unclamped inductive load test circuit

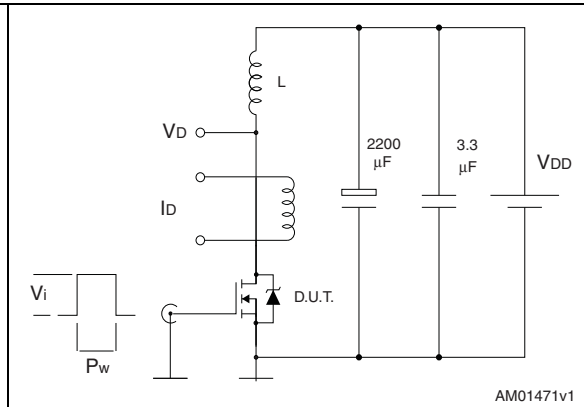

Figure 21. Unclamped inductive waveform

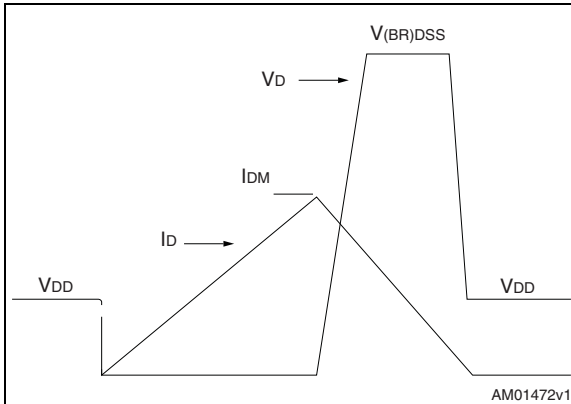
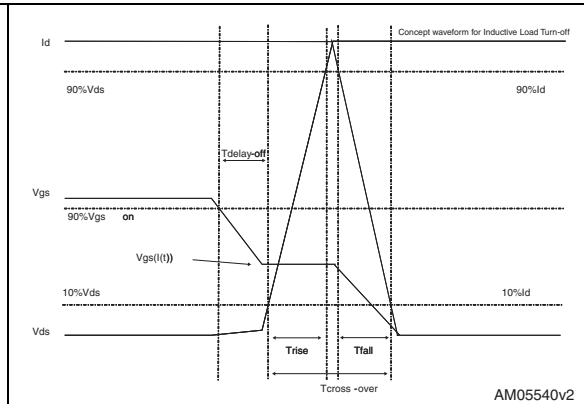

Figure 22. Switching time waveform



## 4 Package mechanical data

In order to meet environmental requirements, ST offers these devices in different grades of ECOPACK<sup>®</sup> packages, depending on their level of environmental compliance. ECOPACK<sup>®</sup> specifications, grade definitions and product status are available at: [www.st.com](http://www.st.com). ECOPACK is an ST trademark.

**Table 8. D<sup>2</sup>PAK (TO-263) mechanical data**

Dim.	mm		
	Min.	Typ.	Max.
A	4.40		4.60
A1	0.03		0.23
b	0.70		0.93
b2	1.14		1.70
c	0.45		0.60
c2	1.23		1.36
D	8.95		9.35
D1	7.50		
E	10		10.40
E1	8.50		
e		2.54	
e1	4.88		5.28
H	15		15.85
J1	2.49		2.69
L	2.29		2.79
L1	1.27		1.40
L2	1.30		1.75
R		0.4	
V2	0°		8°

Figure 23. D<sup>2</sup>PAK (TO-263) drawing

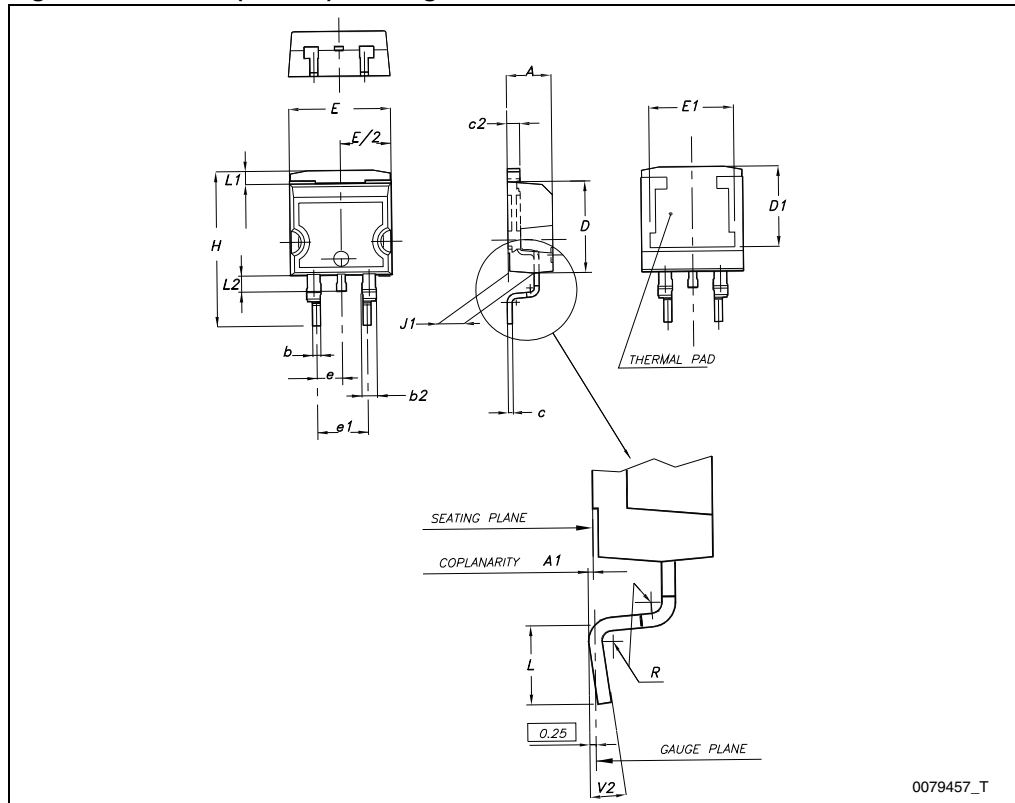
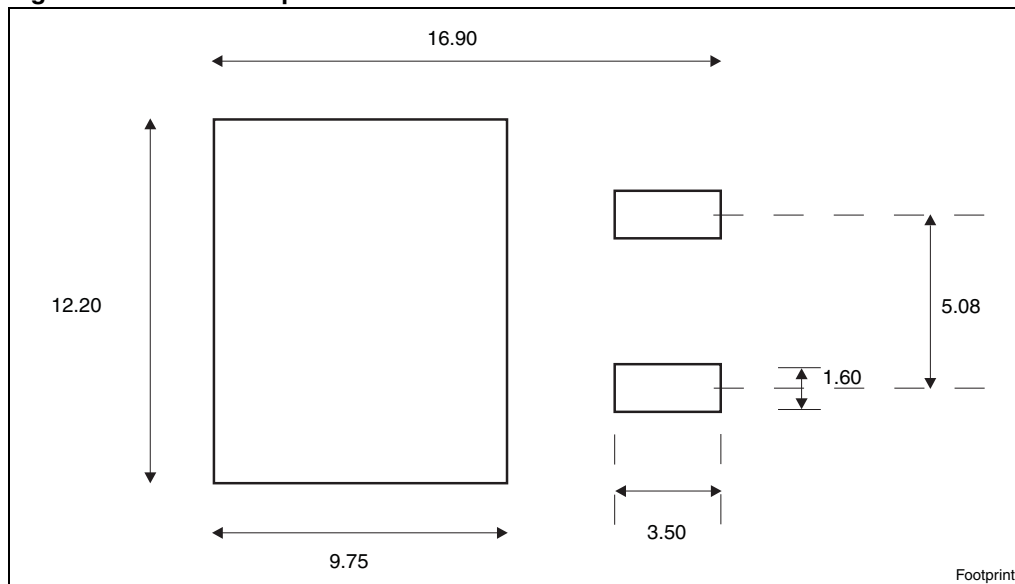

Figure 24. D<sup>2</sup>PAK footprint<sup>(a)</sup>



a. All dimension are in millimeters

Table 9. TO-220FP mechanical data

Dim.	mm		
	Min.	Typ.	Max.
A	4.4		4.6
B	2.5		2.7
D	2.5		2.75
E	0.45		0.7
F	0.75		1
F1	1.15		1.70
F2	1.15		1.70
G	4.95		5.2
G1	2.4		2.7
H	10		10.4
L2		16	
L3	28.6		30.6
L4	9.8		10.6
L5	2.9		3.6
L6	15.9		16.4
L7	9		9.3
Dia	3		3.2

Figure 25. TO-220FP drawing

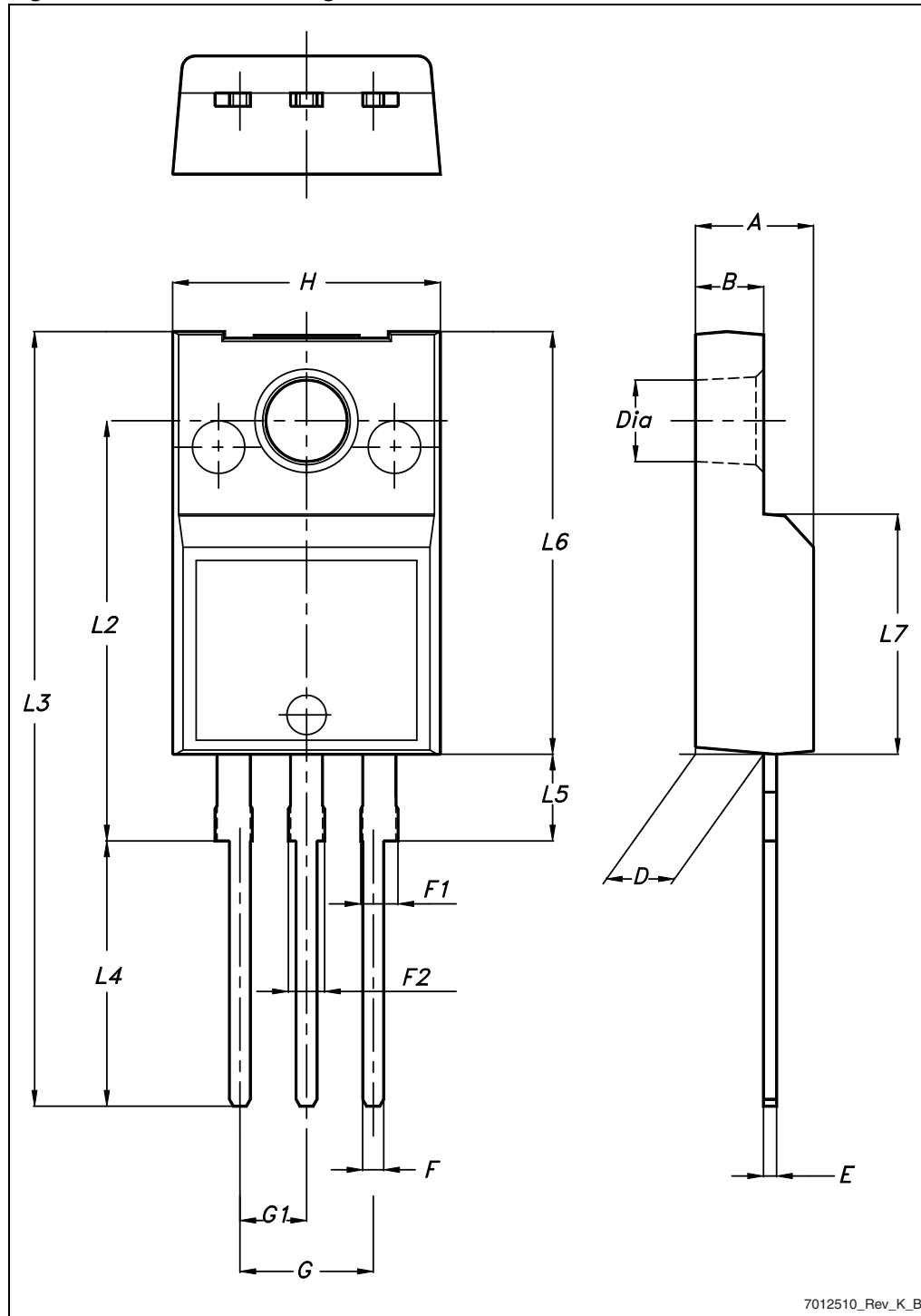

7012510\_Rev\_K\_B

Table 10. I<sup>2</sup>PAK (TO-262) mechanical data

DIM.	mm.		
	min.	typ	max.
A	4.40		4.60
A1	2.40		2.72
b	0.61		0.88
b1	1.14		1.70
c	0.49		0.70
c2	1.23		1.32
D	8.95		9.35
e	2.40		2.70
e1	4.95		5.15
E	10		10.40
L	13		14
L1	3.50		3.93
L2	1.27		1.40

Figure 26. I<sup>2</sup>PAK (TO-262) drawing

Table 11. TO-220 type A mechanical data

Dim.	mm		
	Min.	Typ.	Max.
A	4.40		4.60
b	0.61		0.88
b1	1.14		1.70
c	0.48		0.70
D	15.25		15.75
D1		1.27	
E	10		10.40
e	2.40		2.70
e1	4.95		5.15
F	1.23		1.32
H1	6.20		6.60
J1	2.40		2.72
L	13		14
L1	3.50		3.93
L20		16.40	
L30		28.90	
ØP	3.75		3.85
Q	2.65		2.95



Figure 27. TO-220 type A drawing

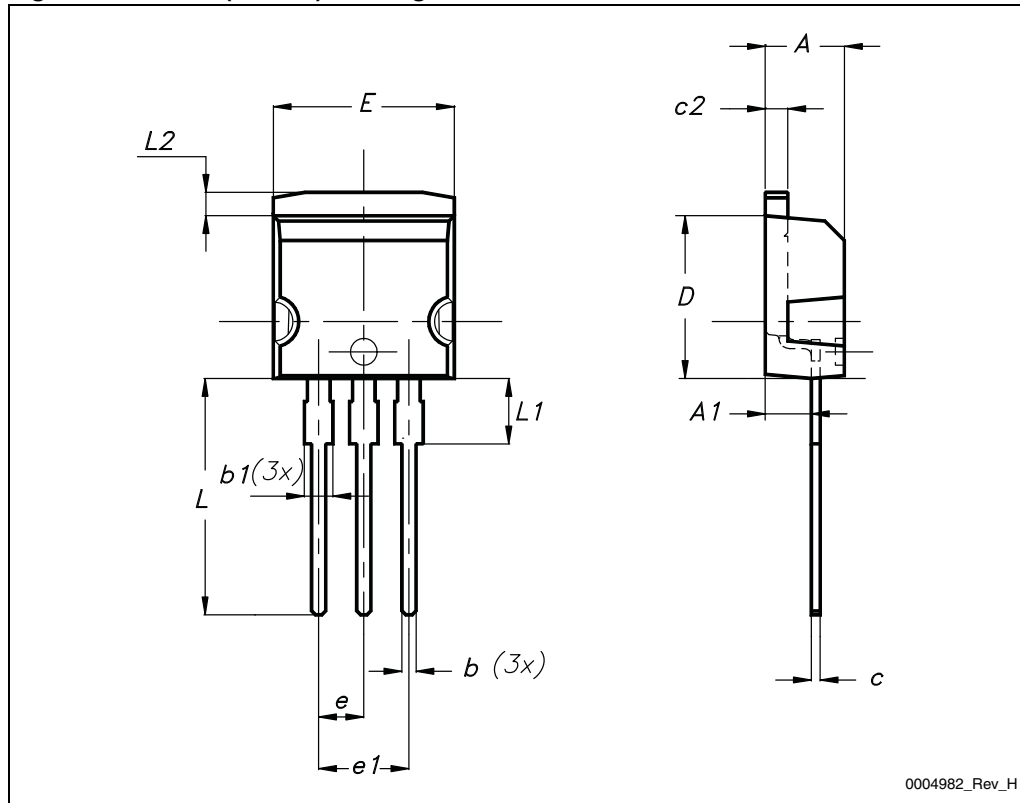
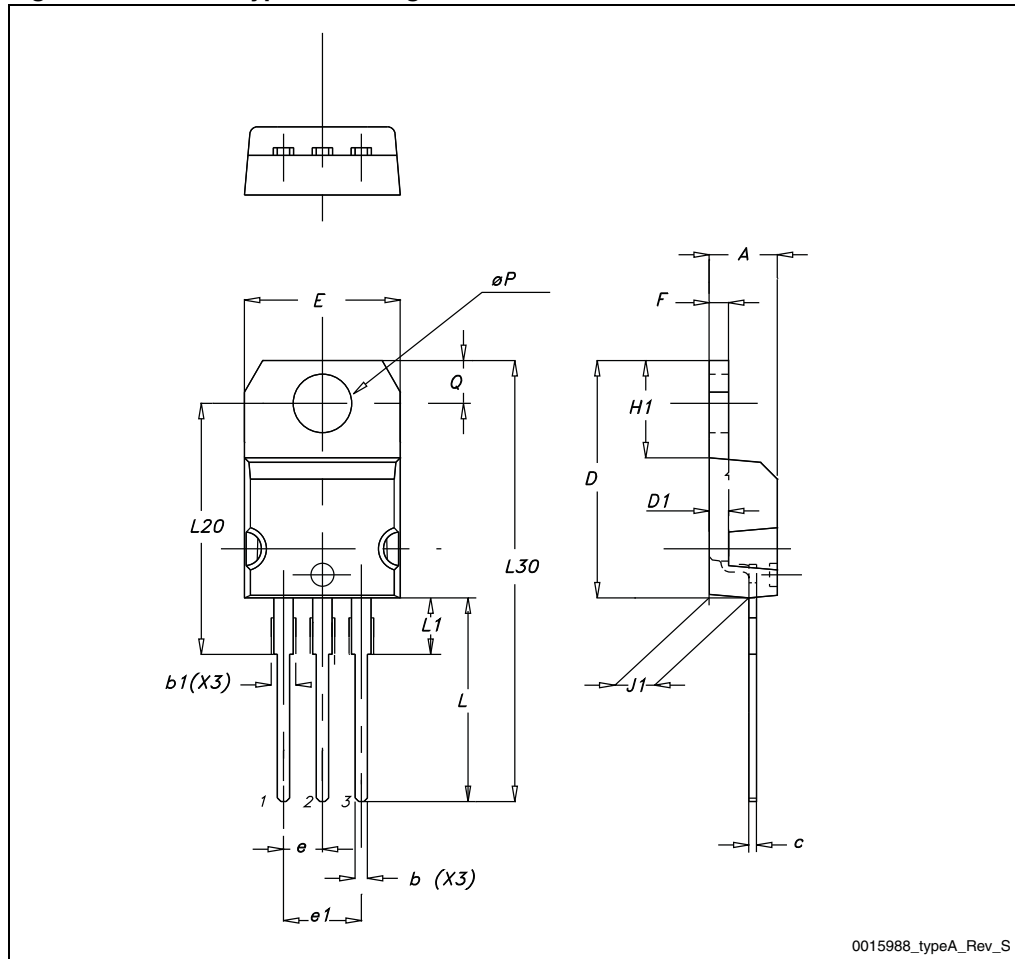

## 5 Packaging mechanical data

Table 12. D<sup>2</sup>PAK (TO-263) tape and reel mechanical data

Tape			Reel		
Dim.	mm		Dim.	mm	
	Min.	Max.		Min.	Max.
A0	10.5	10.7	A		330
B0	15.7	15.9	B	1.5	
D	1.5	1.6	C	12.8	13.2
D1	1.59	1.61	D	20.2	
E	1.65	1.85	G	24.4	26.4
F	11.4	11.6	N	100	
K0	4.8	5.0	T		30.4
P0	3.9	4.1			
P1	11.9	12.1		Base qty	1000
P2	1.9	2.1		Bulk qty	1000
R	50				
T	0.25	0.35			
W	23.7	24.3			

Figure 28. Tape

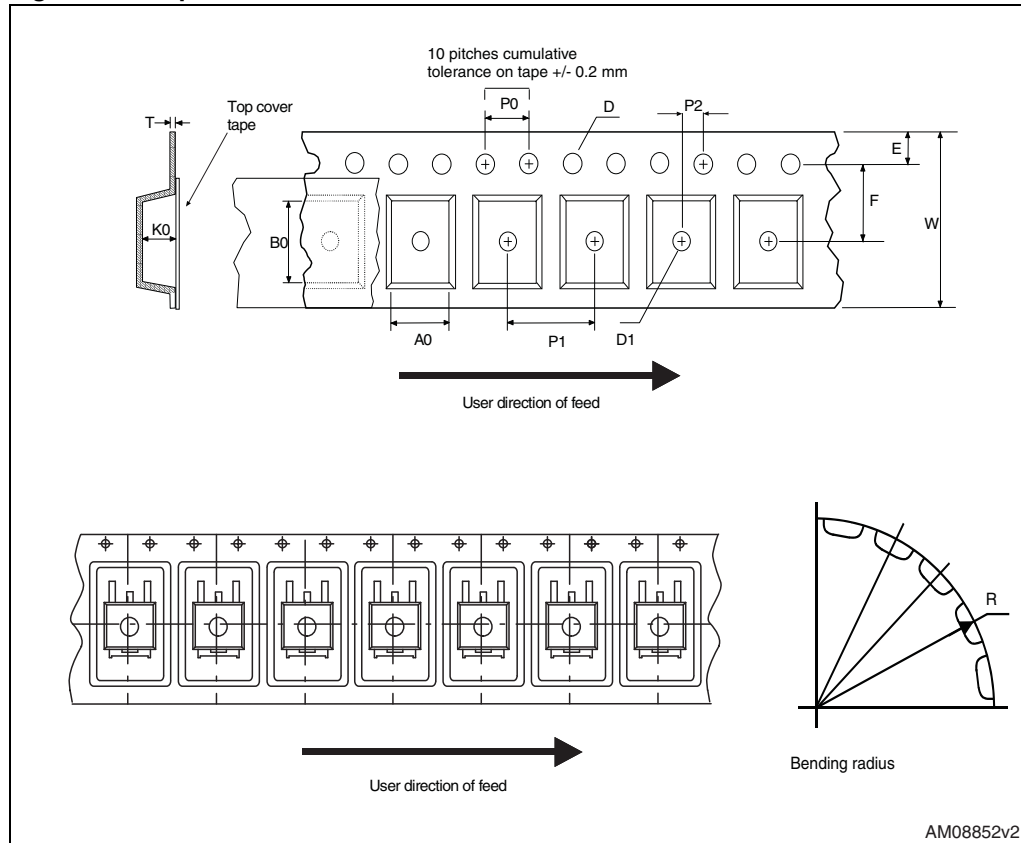
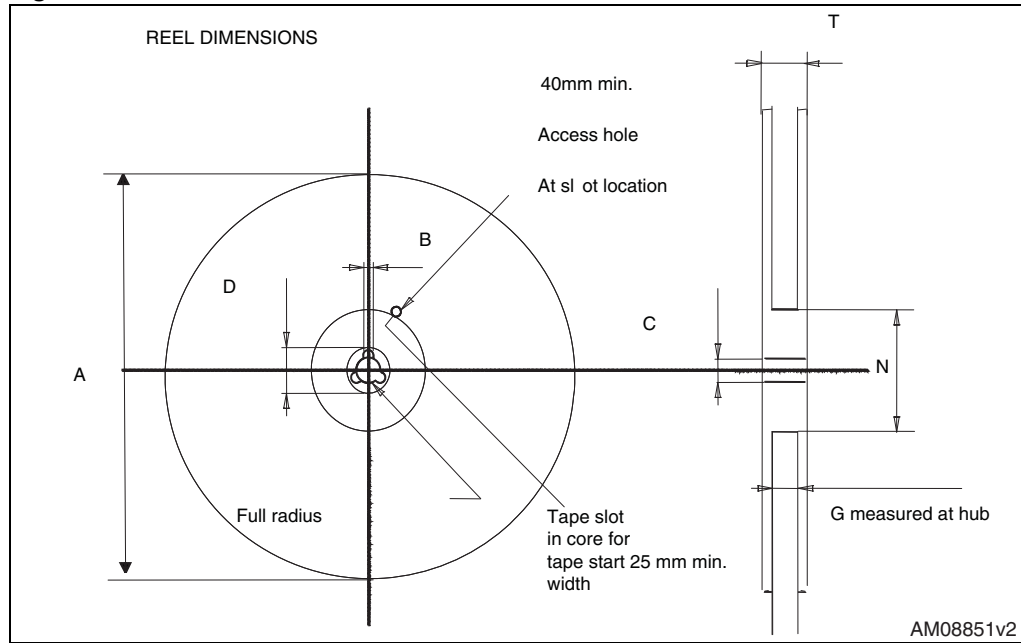

Figure 29. Reel



## 6 Revision history

Table 13. Document revision history

Date	Revision	Changes
06-Apr-2012	1	First release.
04-Jul-2012	2	Document status promoted from preliminary to production data. Added <a href="#">Section 2.1: Electrical characteristics (curves)</a> .
21-Aug-2012	3	Updated symbols and parameters in <a href="#">Table 6: Switching times</a> . Minor text change on the cover page.
04-Dec-2012	4	The part number STW57N65M5 has been moved to a separate datasheet.

**Please Read Carefully:**

Information in this document is provided solely in connection with ST products. STMicroelectronics NV and its subsidiaries ("ST") reserve the right to make changes, corrections, modifications or improvements, to this document, and the products and services described herein at any time, without notice.

All ST products are sold pursuant to ST's terms and conditions of sale.

Purchasers are solely responsible for the choice, selection and use of the ST products and services described herein, and ST assumes no liability whatsoever relating to the choice, selection or use of the ST products and services described herein.

No license, express or implied, by estoppel or otherwise, to any intellectual property rights is granted under this document. If any part of this document refers to any third party products or services it shall not be deemed a license grant by ST for the use of such third party products or services, or any intellectual property contained therein or considered as a warranty covering the use in any manner whatsoever of such third party products or services or any intellectual property contained therein.

**UNLESS OTHERWISE SET FORTH IN ST'S TERMS AND CONDITIONS OF SALE ST DISCLAIMS ANY EXPRESS OR IMPLIED WARRANTY WITH RESPECT TO THE USE AND/OR SALE OF ST PRODUCTS INCLUDING WITHOUT LIMITATION IMPLIED WARRANTIES OF MERCHANTABILITY, FITNESS FOR A PARTICULAR PURPOSE (AND THEIR EQUIVALENTS UNDER THE LAWS OF ANY JURISDICTION), OR INFRINGEMENT OF ANY PATENT, COPYRIGHT OR OTHER INTELLECTUAL PROPERTY RIGHT.**

**UNLESS EXPRESSLY APPROVED IN WRITING BY TWO AUTHORIZED ST REPRESENTATIVES, ST PRODUCTS ARE NOT RECOMMENDED, AUTHORIZED OR WARRANTED FOR USE IN MILITARY, AIR CRAFT, SPACE, LIFE SAVING, OR LIFE SUSTAINING APPLICATIONS, NOR IN PRODUCTS OR SYSTEMS WHERE FAILURE OR MALFUNCTION MAY RESULT IN PERSONAL INJURY, DEATH, OR SEVERE PROPERTY OR ENVIRONMENTAL DAMAGE. ST PRODUCTS WHICH ARE NOT SPECIFIED AS "AUTOMOTIVE GRADE" MAY ONLY BE USED IN AUTOMOTIVE APPLICATIONS AT USER'S OWN RISK.**

Resale of ST products with provisions different from the statements and/or technical features set forth in this document shall immediately void any warranty granted by ST for the ST product or service described herein and shall not create or extend in any manner whatsoever, any liability of ST.

ST and the ST logo are trademarks or registered trademarks of ST in various countries.

Information in this document supersedes and replaces all information previously supplied.

The ST logo is a registered trademark of STMicroelectronics. All other names are the property of their respective owners.

© 2012 STMicroelectronics - All rights reserved

STMicroelectronics group of companies

Australia - Belgium - Brazil - Canada - China - Czech Republic - Finland - France - Germany - Hong Kong - India - Israel - Italy - Japan - Malaysia - Malta - Morocco - Philippines - Singapore - Spain - Sweden - Switzerland - United Kingdom - United States of America

[www.st.com](http://www.st.com)