



AZ23C2V7 THRU AZ23C51

Dual Surface Mount Zener Diode



Voltage Range
2.7 to 51 Volts
300m Watts Power Dissipation

Features

- ✧ Dual zeners in common anode configuration
- ✧ 300 mW power dissipation rating
- ✧ Ideally suited for automated insertion
- ✧ ΔV_z for both diodes in one case is $\leq 5\%$
- ✧ Common cathode style available see DZ series

Mechanical Data

- ✧ Case: SOT-23, Molded plastic
- ✧ Terminals: Solderable per MIL-STD-202, Method 208
- ✧ Polarity: See diagram
- ✧ Marking: Marking Code (see table on Page 2)
- ✧ Mounting position: Any
- ✧ Weight: 0.008 grams (approx.)

SOT-23

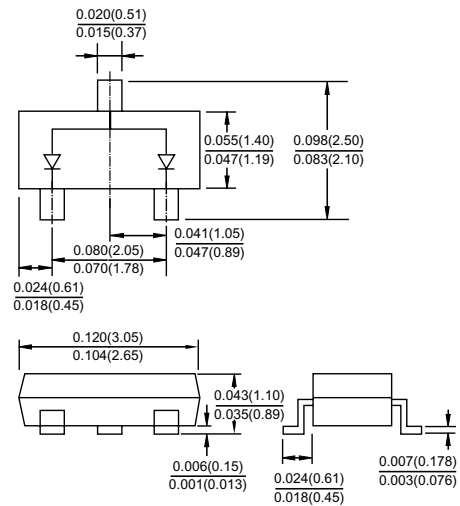

Maximum Ratings and Electrical Characteristics

Rating at 25°C ambient temperature unless otherwise specified.

Maximum Ratings

Type Number	Symbol	Value	Units
Power Dissipation (Note 1)	P _d	300	mW
Thermal Resistance Junction to Ambient Air (Note 1)	R _{θJA}	420	K/W
Operating and Storage Temperature Range	T _J , T _{STG}	-65 to + 150	°C

Notes: 1. Device on Fiberglass Substrate.

2. Tested with IZT Current pulses. Pulse width = 5ms.

ELECTRICAL CHARACTERISTICS (TA=25°C unless otherwise noted)

Device (Note 1)	Device Marking Code	Zener Voltage Range @ I _{ZT} = 5.0mA V _Z (Volts) (Notes 2)	Maximum Zener Impedance		Typical Temperature Coefficient	Min Reverse Voltage @ I _R = 0.1uA V _R (Volts)
			Z _{TT} @ I _{ZT} = 5.0mA	Z _{ZK} @ I _{ZK} = 1.0mA		
			Ohms	Ohms	T _c (%/°C)	
AZ23C2V7	D1	2.5-2.9	83	500	-0.065	-
AZ23C3V0	D2	2.8-3.2	95	500	-0.060	-
AZ23C3V3	D3	3.1-3.5	95	500	-0.055	-
AZ23C3V6	D4	3.4-3.8	95	500	-0.055	-
AZ23C3V9	D5	3.7-4.1	95	500	-0.050	-
AZ23C4V3	D6	4.0-4.6	95	500	-0.035	-
AZ23C4V7	D7	4.4-5.0	78	500	-0.015	-
AZ23C5V1	D8	4.8-5.4	60	480	+0.005	0.8
AZ23C5V6	D9	5.2-6.0	40	400	+0.020	1.0
AZ23C6V2	D10	5.8-6.6	10	200	+0.030	2.0
AZ23C6V8	D11	6.4-7.2	8.0	150	+0.045	3.0
AZ23C7V5	D12	7.0-7.9	7.0	50	+0.050	5.0
AZ23C8V2	D13	7.7-8.7	7.0	50	+0.055	6.0
AZ23C9V1	D14	8.5-9.6	10	50	+0.065	7.0
AZ23C10	D15	9.4-10.6	15	70	+0.065	7.5
AZ23C11	D16	10.4-11.6	20	70	+0.070	8.5
AZ23C12	D17	11.4-12.7	20	90	+0.075	9.0
AZ23C13	D18	12.4-14.1	25	110	+0.080	10.0
AZ23C15	D19	13.8-15.6	30	110	+0.080	11.0
AZ23C16	D20	15.30-17.1	40	170	+0.090	12.0
AZ23C18	D21	16.8-19.1	50	170	+0.090	14.0
AZ23C20	D22	18.8-21.2	50	220	+0.090	15.0
AZ23C22	D23	20.8-23.3	55	220	+0.090	17.0
AZ23C24	D24	22.8-25.6	80	220	+0.090	18.0
AZ23C27	D25	25.1-28.9	80	250	+0.090	20.0
AZ23C30	D26	28-32	80	250	+0.090	22.5
AZ23C33	D27	31-35	80	250	+0.090	25.0
AZ23C36	D28	34-39	90	250	+0.090	27.0
AZ23C39	D29	37-41	90	300	+0.110	29.0
AZ23C43	D30	40-46	100	700	+0.110	32.0
AZ23C47	D31	44-50	100	750	+0.110	35.0
AZ23C51	D32	48-54	100	750	+0.110	38.0

Notes: 1. Device on fiberglass substrate.

2. Tested with I_{ZT} current pulses. Pulse width = 5.0ms.