



Micro Commercial Components



Micro Commercial Components
20736 Marilla Street Chatsworth
CA 91311

Phone: (818) 701-4933

Fax: (818) 701-4939

MMBT3906

PNP General Purpose Amplifier

Features

- Lead Free Finish/RoHS Compliant ("P" Suffix designates RoHS Compliant. See ordering information)
- Epoxy meets UL 94 V-0 flammability rating
- Moisture Sensitivity Level 1
- Capable of 300mWatts of Power Dissipation
- Marking:2A

Maximum Ratings

Symbol	Rating	Rating	Unit
V_{CEO}	Collector-Emitter Voltage	-40	V
V_{CBO}	Collector-Base Voltage	-40	V
V_{EBO}	Emitter-Base Voltage	-5.0	V
I_C	Collector Current, Continuous	-0.2	A
P_D	Power Dissipation	0.3	W
T_J	Operating Junction Temperature	-55 to +150	°C
T_{STG}	Storage Temperature	-55 to +150	°C

Electrical Characteristics @ 25°C Unless Otherwise Specified

Symbol	Parameter	Min	Max	Units
$V_{(BR)CEO}$	Collector-Emitter Breakdown Voltage* ($I_C=-1.0mA$, $I_B=0$)	-40		Vdc
$V_{(BR)CBO}$	Collector-Base Breakdown Voltage ($I_C=-10\mu A$, $I_E=0$)	-40		Vdc
$V_{(BR)EBO}$	Emitter-Base Breakdown Voltage ($I_E=-10\mu A$, $I_C=0$)	-5.0		Vdc
I_{CBO}	Collector cut-off Current ($V_{CB}=-40Vdc$, $I_E=0$)		-0.1	μA
I_{CEX}	Collector Cut-off Current ($V_{CE}=-30Vdc$, $V_{BE}=-3.0Vdc$)		-50	nA
I_{EBO}	Emitter cut-off Current ($V_{EB}=-5Vdc$, $I_C=0$)		-0.1	μA
h_{FE}	DC Current Gain* ($I_C=-10mA$, $V_{CE}=-1.0Vdc$) ($I_C=-50mA$, $V_{CE}=-1.0Vdc$) ($I_C=-100mA$, $V_{CE}=-1.0Vdc$)	100 60 30	300	
$V_{CE(sat)}$	Collector-Emitter Saturation Voltage ($I_C=-10mA$, $I_B=-1.0mA$) ($I_C=-50mA$, $I_B=-5.0mA$)		-0.25 -0.4	Vdc
$V_{BE(sat)}$	Base-Emitter Saturation Voltage ($I_C=-10mA$, $I_B=-1.0mA$) ($I_C=-50mA$, $I_B=-5.0mA$)	-0.65	-0.85 -0.95	Vdc
Cobo	Output Capacitance ($V_{CB}=-5.0Vdc$, $f=1.0MHz$, $I_E=0$)		4.5	pF
Cibo	Input Capacitance ($V_{EB}=-0.5Vdc$, $f=1.0MHz$, $I_C=0$)		10	pF
f_T	Current Gain-Bandwidth Product ($I_C=-10mA$, $V_{CE}=-20Vdc$, $f=100MHz$)	250		MHz
NF	Noise Figure ($V_{CE}=-5.0V$, $f=1.0kHz$, $I_C=-100\mu A$, $R_S=1.0K$)		4.0	dB

SWITCHING CHARACTERISTICS

t_d	Delay Time	($V_{CC}=-3.0Vdc$, $V_{BE}=-0.5Vdc$)	35	ns
t_r	Rise Time	($I_C=-10mA$, $I_{B1}=-1.0mA$)	35	ns
t_s	Storage Time	($V_{CC}=-3.0Vdc$, $I_C=-10mA$)	225	ns
t_f	Fall Time	($I_{B1}=I_{B2}=-1.0mA$)	75	ns

*Pulse Width $\leq 300\mu s$, Duty Cycle $\leq 2.0\%$

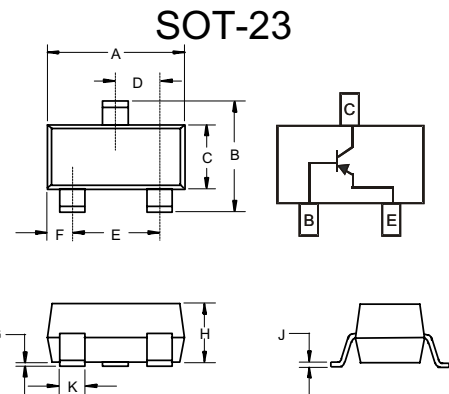

DIM	INCHES		MM		NOTE
	MIN	MAX	MIN	MAX	
A	.110	.120	2.80	3.04	
B	.083	.104	2.10	2.64	
C	.047	.055	1.20	1.40	
D	.035	.041	.89	1.03	
E	.070	.081	1.78	2.05	
F	.018	.024	.45	.60	
G	.0005	.0039	.013	.100	
H	.035	.044	.89	1.12	
J	.003	.007	.085	.180	
K	.015	.020	.37	.51	

Suggested Solder Pad Layout

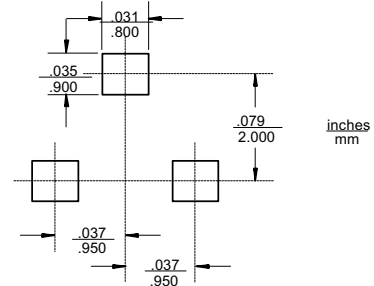

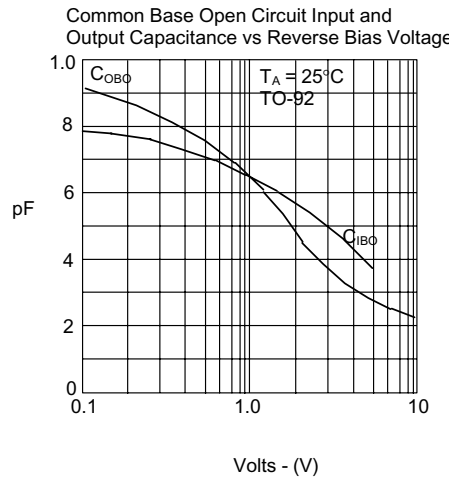
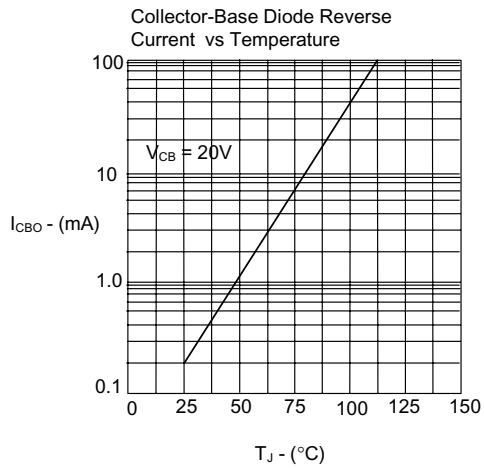
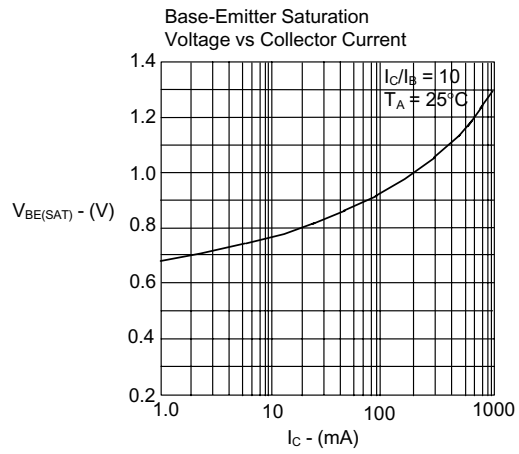
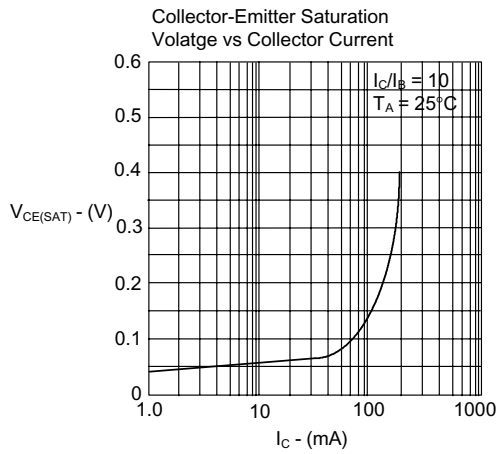
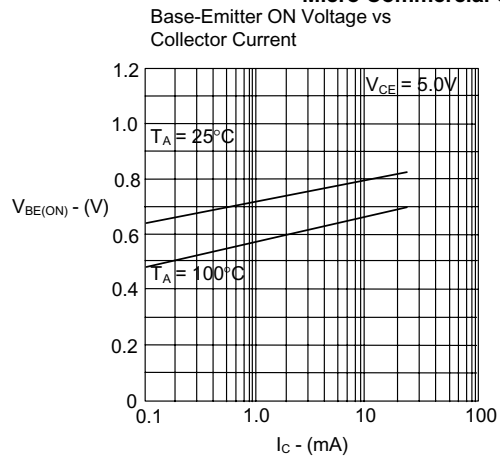
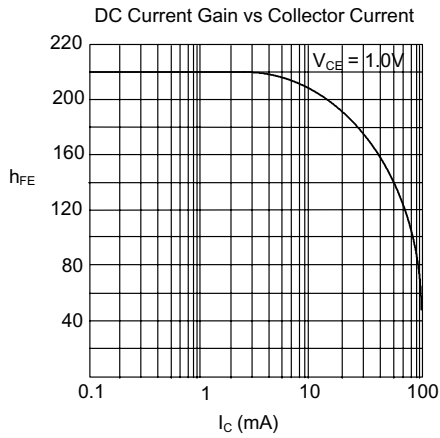

MMBT3906



Micro Commercial Components

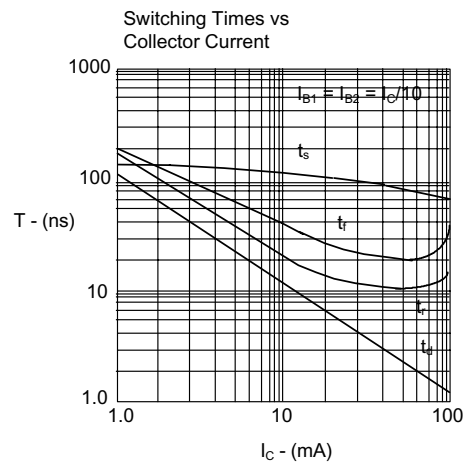
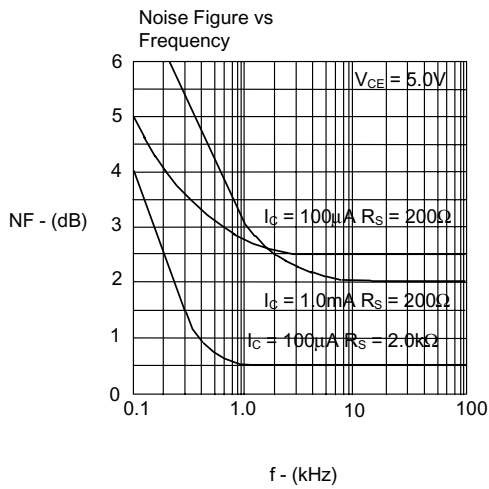
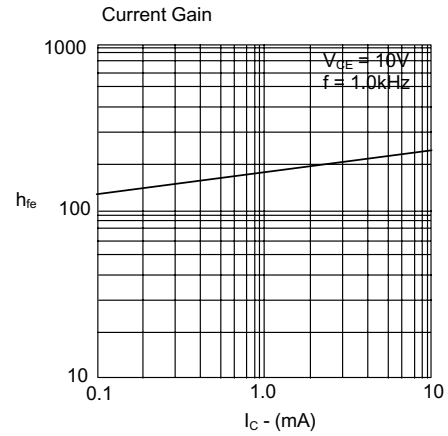
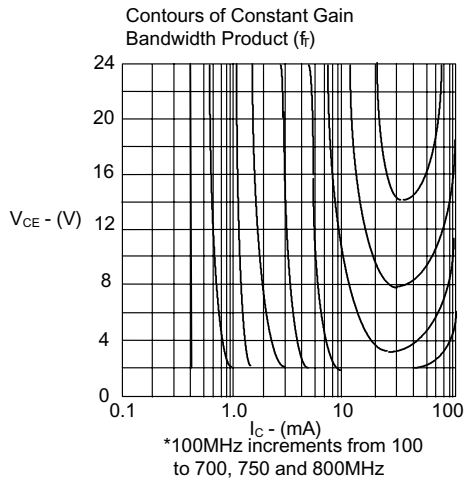
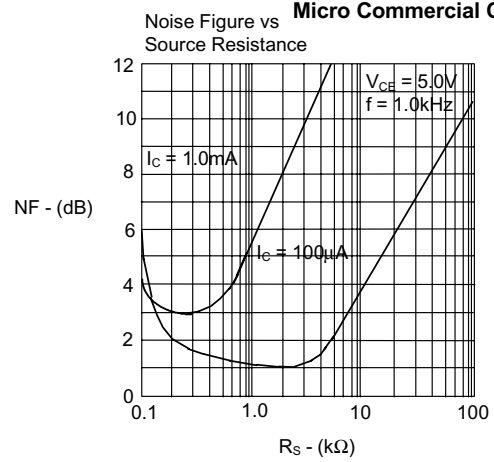
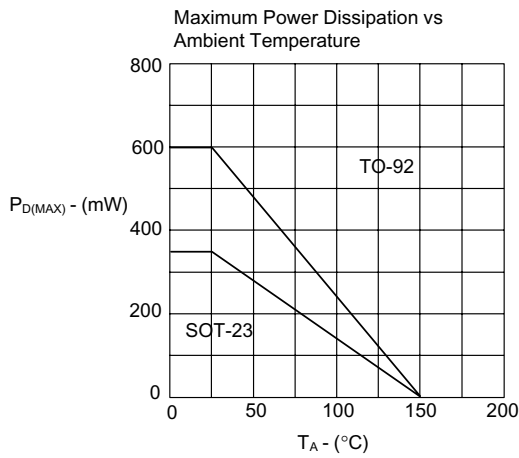

www.mccsemi.com

MMBT3906

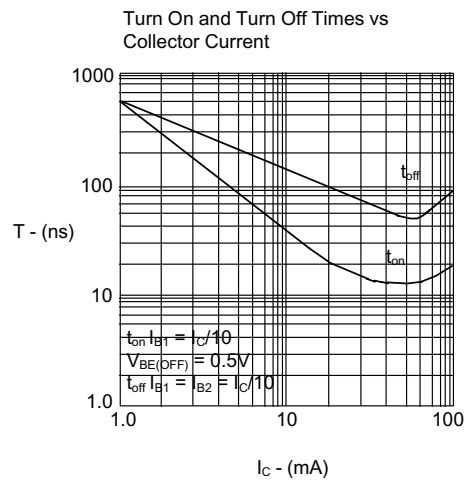
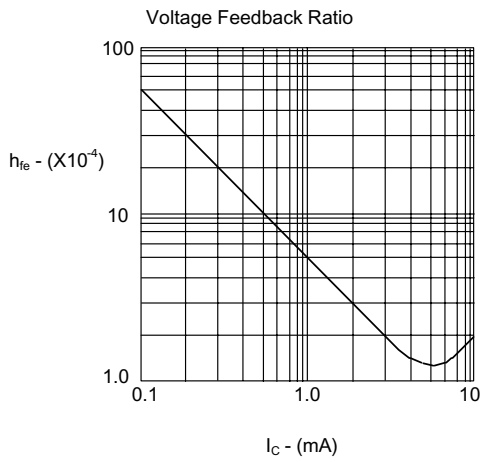
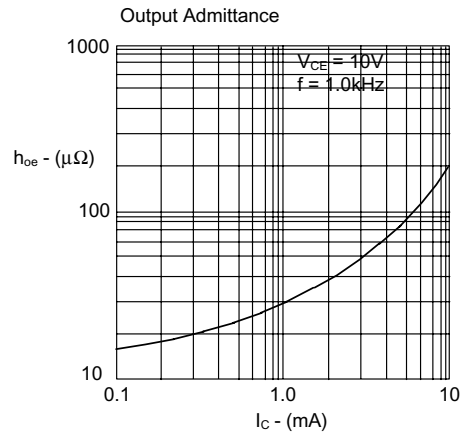
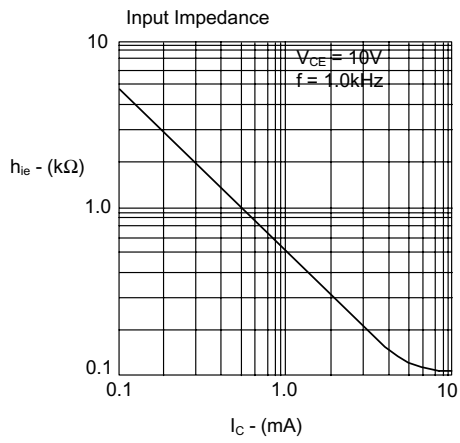

Marking Information

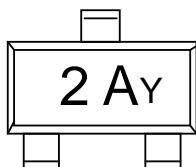

2A = Product Type Marking Code
Y=Date Code Marking

Date code Key (2 years a cycle)

Year	2011											
Month	Jan	Feb	Mar	Apr	May	Jun	Jul	Aug	Sep	Oct	Nov	Dec
Code	J	O	L	C	K	B	P	D	M	E	G	F

Year	2012											
Month	Jan	Feb	Mar	Apr	May	Jun	Jul	Aug	Sep	Oct	Nov	Dec
Code	W	N	Y	T	R	H	A	I	U	X	Z	S



Micro Commercial Components

Ordering Information :

Device	Packing
Part Number-TP	Tape&Reel; 3Kpcs/Reel

*****IMPORTANT NOTICE*****

Micro Commercial Components Corp. reserves the right to make changes without further notice to any product herein to make corrections, modifications , enhancements , improvements , or other changes . **Micro Commercial Components Corp .** does not assume any liability arising out of the application or use of any product described herein; neither does it convey any license under its patent rights ,nor the rights of others . The user of products in such applications shall assume all risks of such use and will agree to hold **Micro Commercial Components Corp .** and all the companies whose products are represented on our website, harmless against all damages.

*****LIFE SUPPORT*****

MCC's products are not authorized for use as critical components in life support devices or systems without the express written approval of Micro Commercial Components Corporation.

*****CUSTOMER AWARENESS*****

Counterfeiting of semiconductor parts is a growing problem in the industry. Micro Commercial Components (MCC) is taking strong measures to protect ourselves and our customers from the proliferation of counterfeit parts. MCC strongly encourages customers to purchase MCC parts either directly from MCC or from Authorized MCC Distributors who are listed by country on our web page cited below. Products customers buy either from MCC directly or from Authorized MCC Distributors are genuine parts, have full traceability, meet MCC's quality standards for handling and storage. **MCC will not provide any warranty coverage or other assistance for parts bought from Unauthorized Sources.** MCC is committed to combat this global problem and encourage our customers to do their part in stopping this practice by buying direct or from authorized distributors.

www.mccsemi.com