



## DS2731 Evaluation Kit

### General Description

The DS2731 evaluation kit (EV kit) demonstrates all the features of the DS2731 battery-backup power-management IC. The EV kit includes an assembled and tested PCB for easy connection to power sources and a load. Three power sources—a 3.3V auxiliary supply, a 12V supply, and a single lithium-ion (Li+) battery—connect to the DS2731 EV kit to supply the high-efficiency, synchronous buck regulator and battery charger. The IC automatically selects the best-qualified power source for the buck regulator. Thresholds for low-battery voltage, charge regulation voltage and current, charge safety timer, and buck-output voltage are set by resistors.

### Features

- ◆ Convenient Power Source and Load Connections
- ◆ LEDs Indicate Charge Status
- ◆ Automatic Power-Source Selection
- ◆ Space for a Wide Variety of Inductor Sizes
- ◆ Proven, Compact and Low-Cost PCB Layout
- ◆ Fully Assembled

### Ordering Information

PART	TYPE
DS2731EVKIT+	EV Kit

+Denotes lead(Pb)-free and RoHS compliant.

### Component List

DESIGNATION	QTY	DESCRIPTION
C1, C7	2	10 $\mu$ F ceramic SMT capacitors
C2, C3, C6	3	47 $\mu$ F ceramic SMT capacitors
C4, C5	2	22 $\mu$ F ceramic SMT capacitors
G	1	Green LED L62305CT
JP1	1	No power
JP2	1	0 $\Omega$ resistor (0603)
L1	1	2.2 $\mu$ H power inductor
L2	1	6.8 $\mu$ H power inductor
R	1	Red LED L62301CT
R1	1	56.2k $\Omega$ resistor (0603)
R2	1	10.2k $\Omega$ resistor (0603)
R3	1	590k $\Omega$ resistor (0603)

DESIGNATION	QTY	DESCRIPTION
R4	1	240k $\Omega$ resistor (0603)
R5	1	360k $\Omega$ resistor (0603)
R6, R7, R8, R11, R12	5	4.7k $\Omega$ resistor (0603)
R9	1	0.05k $\Omega$ resistor (1206)
R13	1	2.49k $\Omega$ resistor (0603)
THM1	1	103AT-2 thermistor
U1	1	Cache-memory battery-backup management IC (28 TSSOP) DS2731E+
Y	1	Yellow LED L62307CT
—	1	PCB: DS2731 Evaluation Kit+

Evaluates: DS2731

# DS2731 Evaluation Kit

## Quick Start Sequence

### Required Equipment

Before beginning, the following equipment is needed:

- DS2731 EV Kit Board
- +12V Power Supply
- +3.3V Power Supply
- +4.2V Li+ Battery
- Voltmeter
- Connecting Wires

### Optional Equipment

The following equipment is recommended but not required:

- Programmable Load (150mA at +1.7V typical)
- Source/Sink Power Supply

### Board Connections

- 1) Connect a +4.2V source/sink supply or a Li+ battery between BAT+ and BAT-.

- 2) Connect a +12V supply between VIN and CGND.
- 3) Connect a +3.3V supply between AUX and CGND.
- 4) Connect a load between MEM+ and MEM- (optionally connect a voltage meter).
- 5) Verify the regulator output at MEM+/MEM-, which should be close to +1.8V with no load.

**Caution: Always observe proper ESD precautions when handling the DS2731 EV kit circuit board.**

### Supply Connections

A valid +12V and +3.3V supply are required for the charger circuitry to function. The charge current is drawn directly from the +12V supply. The majority of the device logic and the buck regulator are powered off the +3.3V auxiliary supply. These supplies share a common ground at CGND.

### Battery Connection

Connect a +4.2V Li+ cell between BAT+ and BAT-. A source/sink supply can be used for board evaluation purposes.

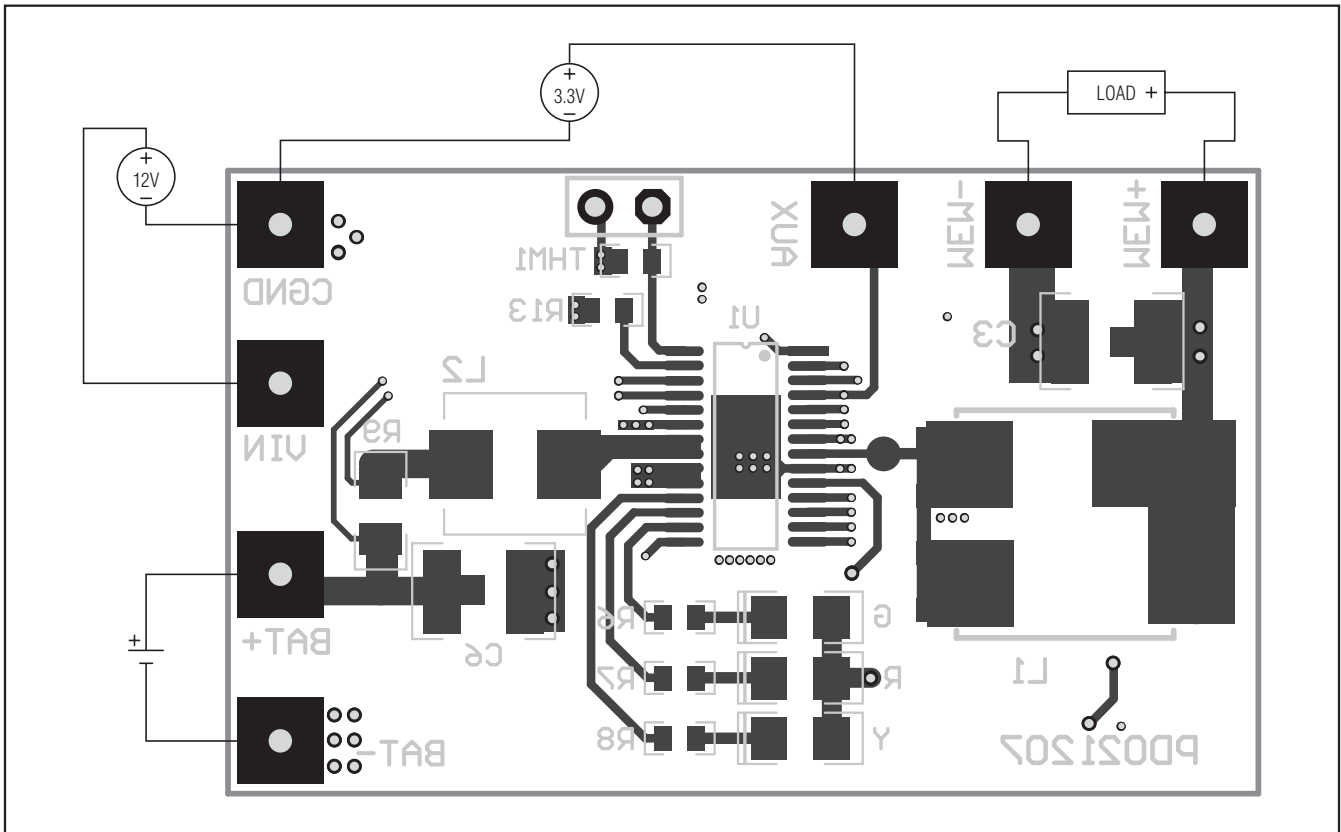

Figure 1. Quick Start Connection Diagram

# DS2731 Evaluation Kit

## Board Configuration

### Charger/Buck Regulator Enables (ENS, ENC)

The charger circuitry can be disabled by removing the 0Ω resistor on JP2. The board is shipped with the 0Ω resistor in place (charger enabled).

Similarly, the buck regulator can be disabled by pulling  $\overline{\text{ENS}}$  high through a 0Ω resistor on JP1. The board is shipped without the 0Ω resistor in place (buck regulator enabled).

### Setting Charge Parameters

#### Constant Current (CC)

Current is regulated based on the voltage drop across an external 50mΩ sense resistor and an internal feedback circuit. The CC charge rate,  $I_{\text{CHARGE}}$ , is set at the RSET pin. It can be calculated by the following formula:

$$I_{\text{CHARGE}} = 2500/R$$

where R is the value of the resistor connected to RSET. The charge current can range from 0.5A to 1.5A. The board is shipped with  $I_{\text{CHARGE}} = 1.00\text{A}$ .

#### Constant Voltage (CV)

When the battery voltage reaches the CV output threshold, CV mode is entered. The charger stops regulating current and begins regulating voltage. The MARGIN pin sets the CV threshold according to the following formula:

$$V_{\text{PK}} (\text{CV set point}) = 4.97\text{V} \times R1/(R2 + R1)$$

where R2 is the resistor between STMR and MARGIN, and R1 is the resistor between MARGIN and ground. Voltage regulation can be set from +3.8V to +4.6V. The board is shipped with  $V_{\text{PK}} = +4.21\text{V}$ .

#### SMTR

The charger has a safety timer that sets the maximum length of time for a charge cycle. It is programmable from 1hr to 10hr.

Timing Equation:

$$0.1647 \times R_{\text{STMR}} = t(\text{s}); R_{\text{STMR}} = R1 + R2$$

The board is shipped with  $t = 10,936\text{s} = 3.04\text{hr}$ . If this timer expires and the battery fails to reach the termination current, the charger enters the fault state and is latched off. Charging does not continue until either the

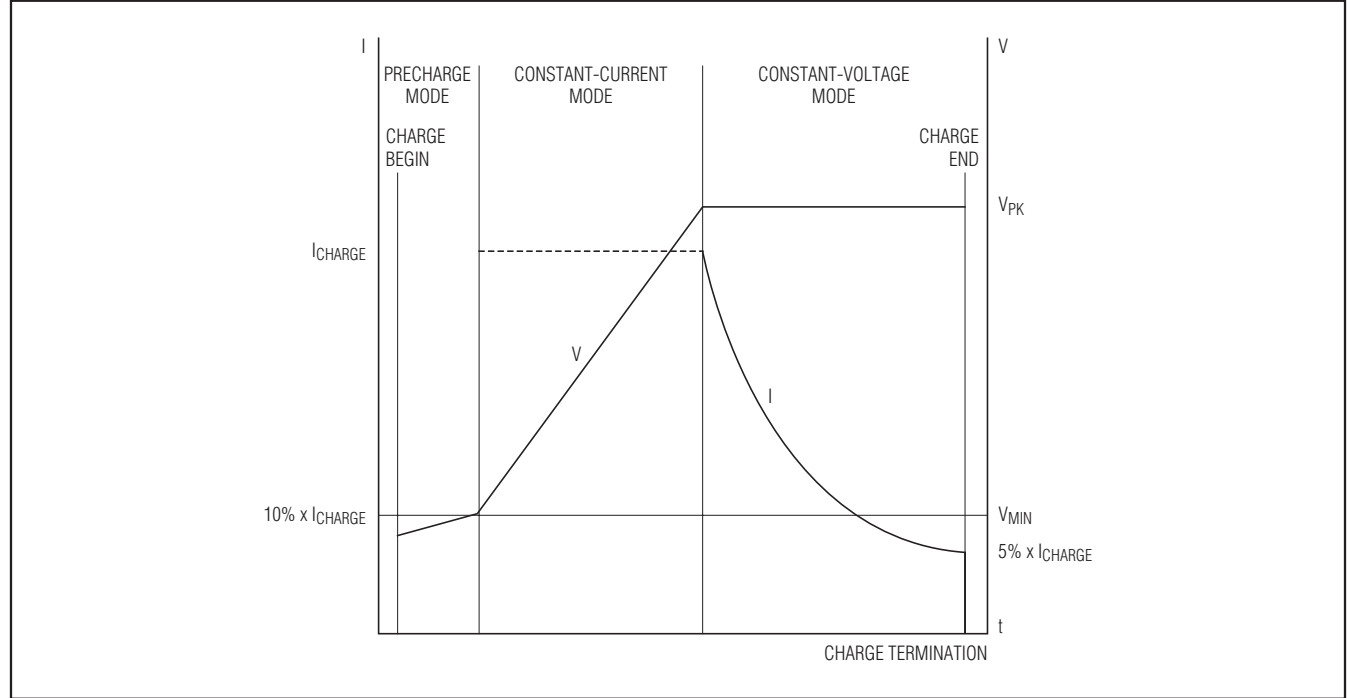

Figure 2. Li+ Charge Cycle

## DS2731 Evaluation Kit

power is cycled or the ENC pin is strobed low and then returns high. The timer does not start until CC mode is entered and continues through CV mode; precharge mode is not included in the STMR.

### **Buck Regulator Regulation Voltage**

The buck regulator output voltage can range from +0.9V to +2.5V and is set by the following formula:

$$V_{DIV} \times 25/12 = V_{VREG}$$

The board is shipped with  $V_{REG} = +1.8V$ .

### **Low-Battery Shutdown**

The supply powering the buck regulator is the auxiliary supply as long as it is  $> 2.93V$ . If the voltage of the auxiliary supply drops below 2.93V, the DS2731 automatically switches power to the Li+ battery.

The IC transitions to a quiescent-power mode should the Li+ battery reach empty before the system power is restored. In this mode, all circuitry is shut off and does not turn on again until the  $V_{CBIAS}$  voltage is stable and UVLO-REG is off. The low-battery voltage set point can be determined by the following formula:

$$V_{LO\_BATT} \times 4.5 = \text{low-battery voltage set point}$$

The board is shipped with the low-battery voltage set point = +2.76V.

## **Board Operation**

### **Charger**

The features of the charge circuitry can be easily demonstrated when a source/sink supply is connected between BAT+ and BAT-. With the +12V and +3.3V supplies connected and on, lower the source/sink supply's voltage below +4.0V (make sure the current limit of the supply is set above the charge current  $I_{CHARGE}$ ). The yellow LED should turn on. If the source/sink supply has a current meter display, it should read approximately equal to  $I_{CHARGE}$ . Lower the source/sink supply voltage below  $V_{MIN}$  and there is a reduction in the charge current. Increase the source/sink supply voltage above  $V_{PK}$ , the constant voltage set point, and observe the green LED turn on.

Heat the IC up to  $> +160^{\circ}C$ . Above  $+100^{\circ}C$ , the IC begins to choke the charge current 133mA/ $^{\circ}C$ . Once the die temperature exceeds  $+160^{\circ}C$ , the charge current shuts off completely.

### **Buck Regulator**

With the +12V and +3.3V supplies and the Li+ battery connected, the voltage reading between MEM+ and MEM- should be approximately +1.8V. If a programmable load is being used, set the load current to 150mA. The user should be able to observe the current being drawn from the +3.3V auxiliary supply. Power down the +12V and +3.3V supplies and observe that the buck regulator is still running. Power up the +12V and +3.3V supplies again and operation of the buck regulator should remain constant during the switchovers.

# DS2731 Evaluation Kit

Evaluates: DS2731

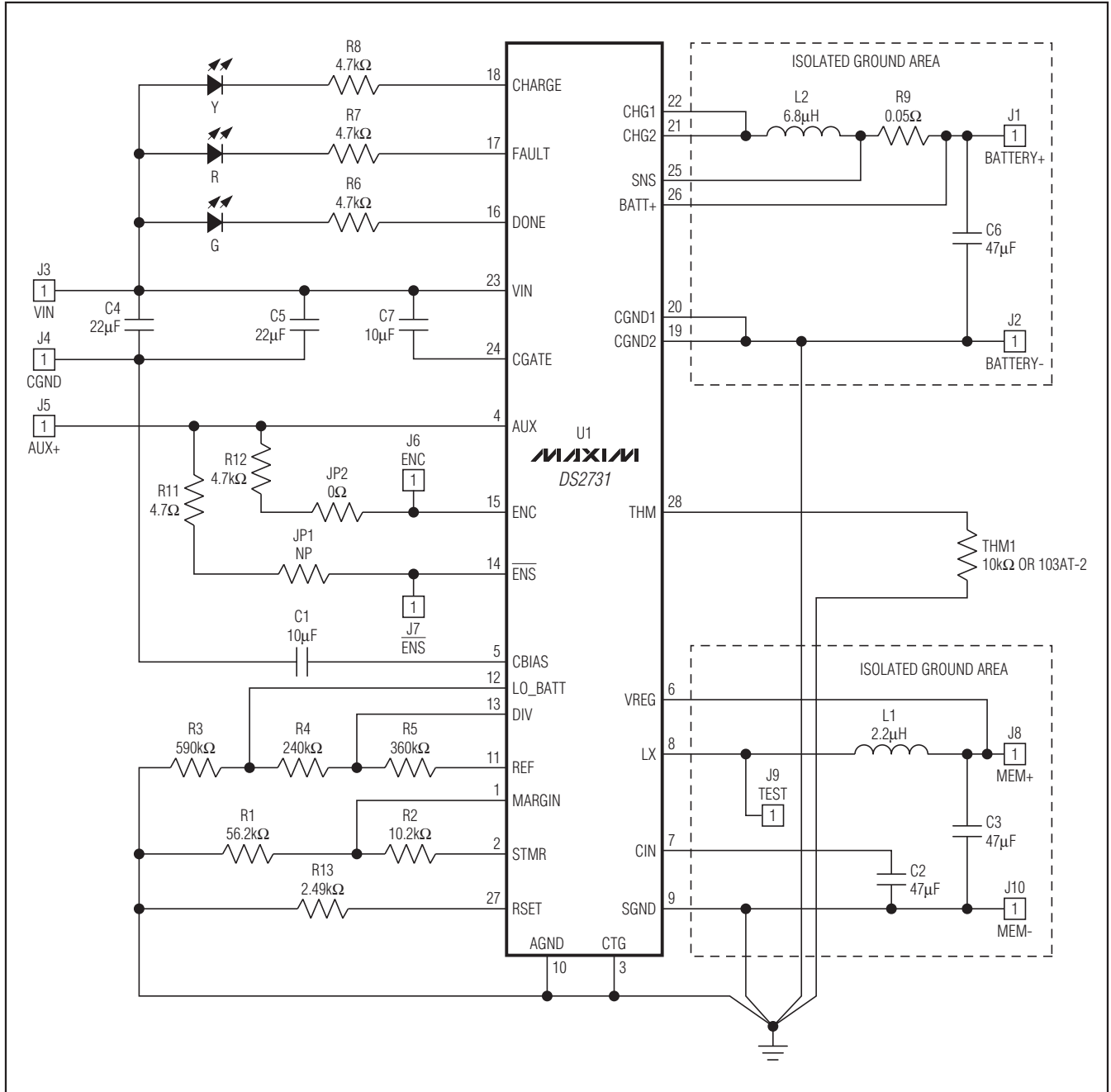

Figure 3. DS2731 EV Kit Board Schematic

# DS2731 Evaluation Kit

Evaluates: DS2731

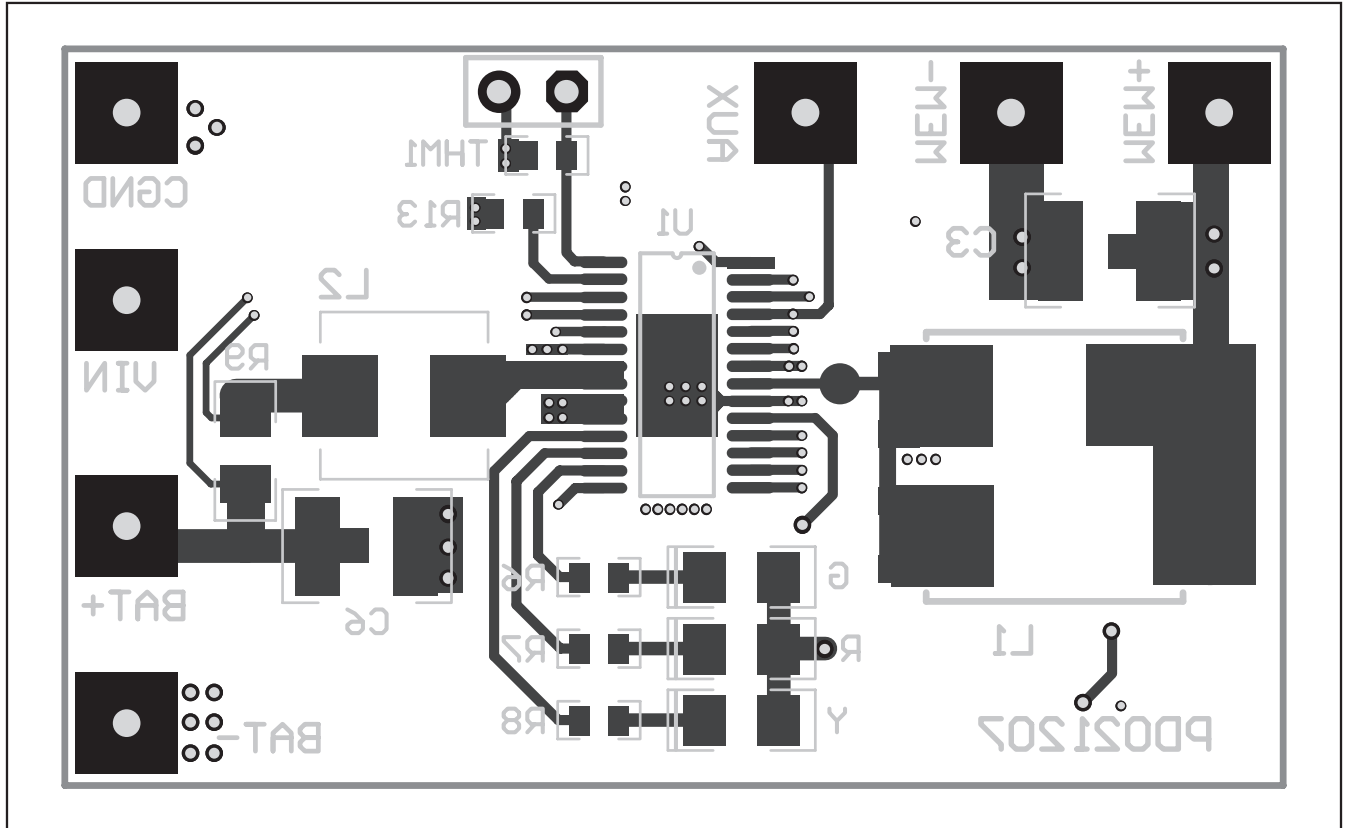

Figure 4. DS2731 EV Kit Board—Top View

# DS2731 Evaluation Kit

Evaluates: DS2731

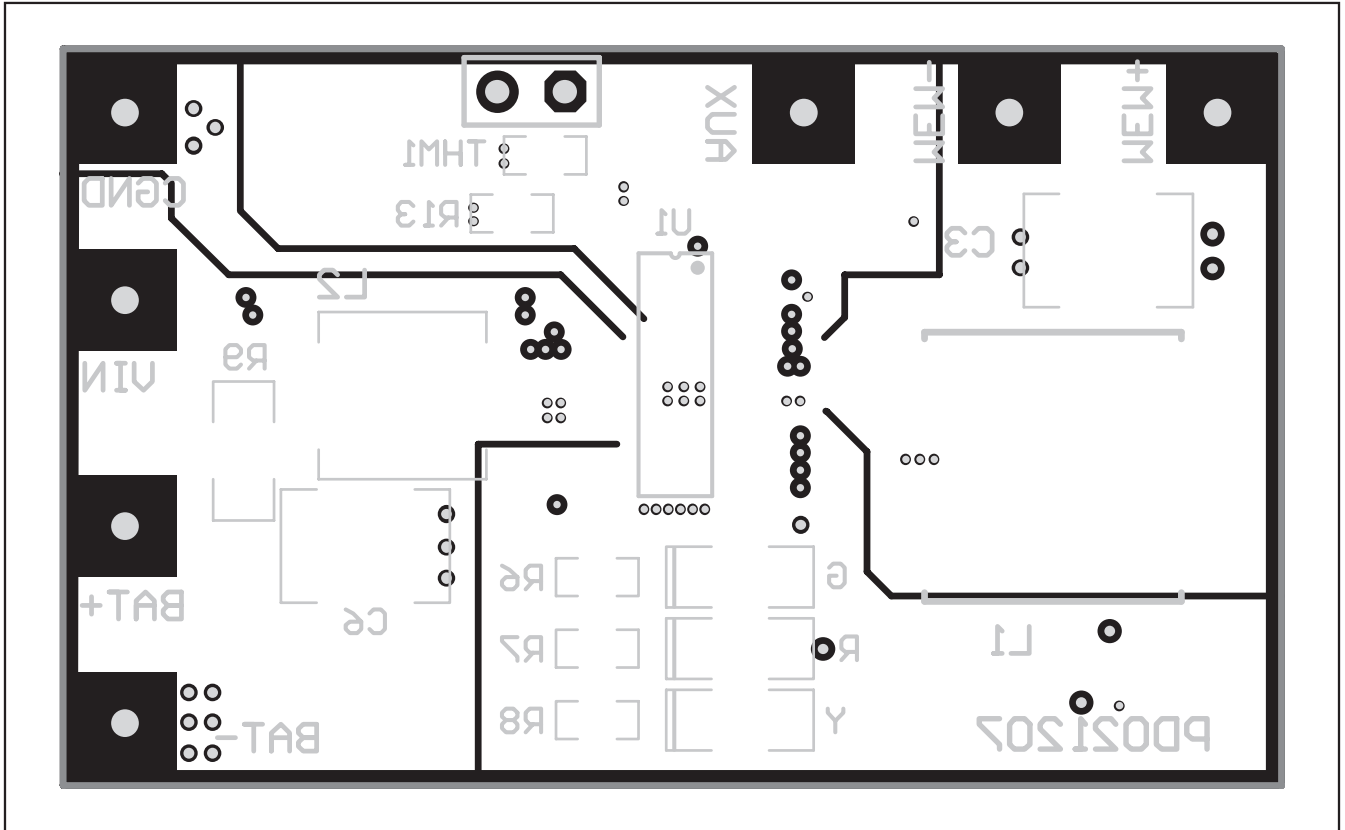

Figure 5. DS2731 EV Kit Board—Middle Layer

# DS2731 Evaluation Kit

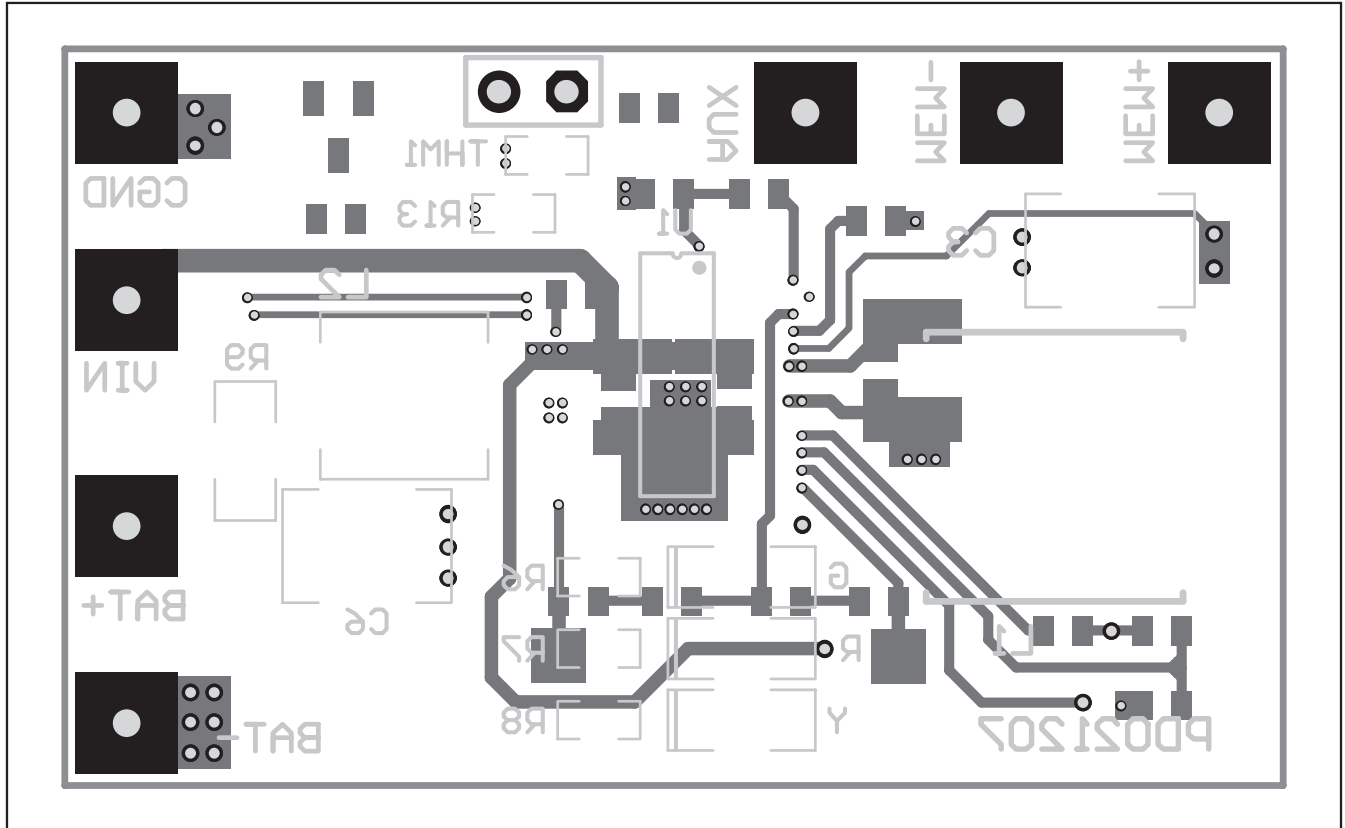

Figure 6. DS2731 EV Kit Board—Bottom Layer



# DS2731 Evaluation Kit

## Revision History

REVISION NUMBER	REVISION DATE	DESCRIPTION	PAGES CHANGED
0	1/09	Initial release.	—
1	10/09	Changed the part number in the <i>Ordering Information</i> table from DS2731K to DS2731EVKIT+.	1

Evaluates: DS2731

Maxim cannot assume responsibility for use of any circuitry other than circuitry entirely embodied in a Maxim product. No circuit patent licenses are implied. Maxim reserves the right to change the circuitry and specifications without notice at any time.

**Maxim Integrated Products, 120 San Gabriel Drive, Sunnyvale, CA 94086 408-737-7600** \_\_\_\_\_ **9**

© 2009 Maxim Integrated Products

Maxim is a registered trademark of Maxim Integrated Products, Inc.