



MAX1625 Evaluation Kit

Evaluates: MAX1625

General Description

The MAX1625 evaluation kit (EV kit) provides a 2.5V output voltage from a 4.5V to 5.5V input. It delivers up to 5A output current with greater than 90% efficiency. The MAX1625 features a resistor-programmable switching frequency from 100kHz to 1MHz, as well as current-mode operation for superior load- and line-transient response. This EV kit operates at a 500kHz switching frequency. It can also be used to evaluate other output voltages by changing feedback resistors R2 and R3.

Features

- ◆ 4.5V to 5.5V Input Voltage Range
- ◆ 2.5V Output Voltage (1.1V to 4.0V adjustable)
- ◆ 5A Output Current
- ◆ Efficiency = 91%, $V_{IN} = 5V$, $V_{OUT} = 2.5V @ I_{OUT} = 2.5A$
- ◆ Power-OK Output
- ◆ 500kHz Switching Frequency
- ◆ 16-Pin Narrow SO
- ◆ Low-Profile Components
- ◆ Fully Assembled and Tested

Ordering Information

PART	TEMP. RANGE	BOARD TYPE
MAX1625EVKIT	0°C to +70°C	Surface Mount

Component List

DESIGNATION	QTY	DESCRIPTION
C1	1	100µF, 10V electrolytic capacitor Sanyo 10SL100M
C2, C3	2	220µF, 4V electrolytic capacitors Sanyo 4SP220M
C4, C5, C9	3	0.1µF ceramic capacitors
C6	1	2.2µF ceramic capacitor
C7, C8	2	4.7µF, 16V tantalum capacitors Sprague 595D475X0016A2T
C10	0	Open
C11, C12	2	4700pF ceramic capacitors
CC1	1	1000pF ceramic capacitor
CC2	1	0.056µF ceramic capacitor
D1 (optional)	1	Schottky diode Nihon NSQ03A02 or Motorola MBRS340T3
D2	1	Schottky diode Central Semiconductor CMPSH-3
L1	1	1.5µH power inductor Coiltronix UP2-1R5, Coilcraft DO3316P-152, or Sumida CDRH127-1R3

DESIGNATION	QTY	DESCRIPTION
N1, N2	2	N-channel MOSFETs (SO-8) International Rectifier IRF7413 or Siliconix Si4410DY
R1	1	0.012Ω, 1%, 1W resistor Dale WSL-2512-R012-F or IRC LR2512-01-R012-F
R2	1	127kΩ, 1% resistor
R3	1	100kΩ, 1% resistor
R4	1	40.2kΩ, 1% resistor
R5	1	100kΩ, 5% resistor
R6	1	100Ω, 5% resistor
R7, R8	2	39Ω, 5% resistors
R9	1	1kΩ, 5% resistor
U1	1	MAX1625ESE
JU1	1	2-pin header
None	1	Shunt
None	1	MAX1625 PC board
None	1	MAX1625 data sheet



MAX1625 Evaluation Kit

Component Suppliers

SUPPLIER*	PHONE	FAX
AVX	(803) 946-0690	(803) 626-3123
Central Semiconductor	(516) 435-1110	(516) 435-1824
Coilcraft	(708) 639-6400	(708) 639-1469
Dale-Vishay	(402) 564-3131	(402) 563-6418
International Rectifier	(310) 322-3331	(310) 322-3332
IRC	(512) 992-7900	(512) 992-3377
Motorola	(602) 303-5454	(602) 994-6430
Nihon	(805) 867-2555	(805) 867-2698
Sanyo	(619) 661-6835	(619) 661-1055
Siliconix	(408) 988-8000	(408) 970-3950
Sprague	(603) 224-1961	(603) 224-1430
Sumida	(847) 956-0666	(847) 956-0702
Vishay/Vitramon	(203) 268-6261	(203) 452-5670

* Please indicate that you are using the MAX1625 when contacting these component suppliers.

Quick Start

The MAX1625 EV kit is fully assembled and tested. Follow these steps to verify board operation. **Do not turn on the power supply until all connections are completed.**

- 1) Connect a 5V supply voltage to the VIN pad. The ground connects to the GND pad.
- 2) Connect a voltmeter and load, if any, to the VOUT pad.
- 3) Remove the shunt from JU1.
- 4) Turn on the power supply to the board. Verify that the output voltage is 2.5V.

Detailed Description

The MAX1625 provides a 2.5V output from 4.5V to 5.5V input voltage. It delivers up to 5A and operates at 500kHz. Other output voltages can be programmed by changing the feedback resistor R2. R2 is given by:

$$R2 = R3 \left(\frac{V_{OUT}}{1.1} - 1 \right)$$

where R3 = 100kΩ.

Jumper Selection

The 2-pin header JU1 selects the shutdown mode. Table 1 lists the selectable jumper options.

Table 1. Jumper JU1 Functions

SHUNT LOCATION	REF PIN	MAX1625 OUTPUT
On	Connected to GND	Shutdown mode, V _{OUT} = 0V
Off	Floating	MAX1625 enabled, V _{OUT} = 2.5V

MAX1625 Evaluation Kit

Evaluates: MAX1625

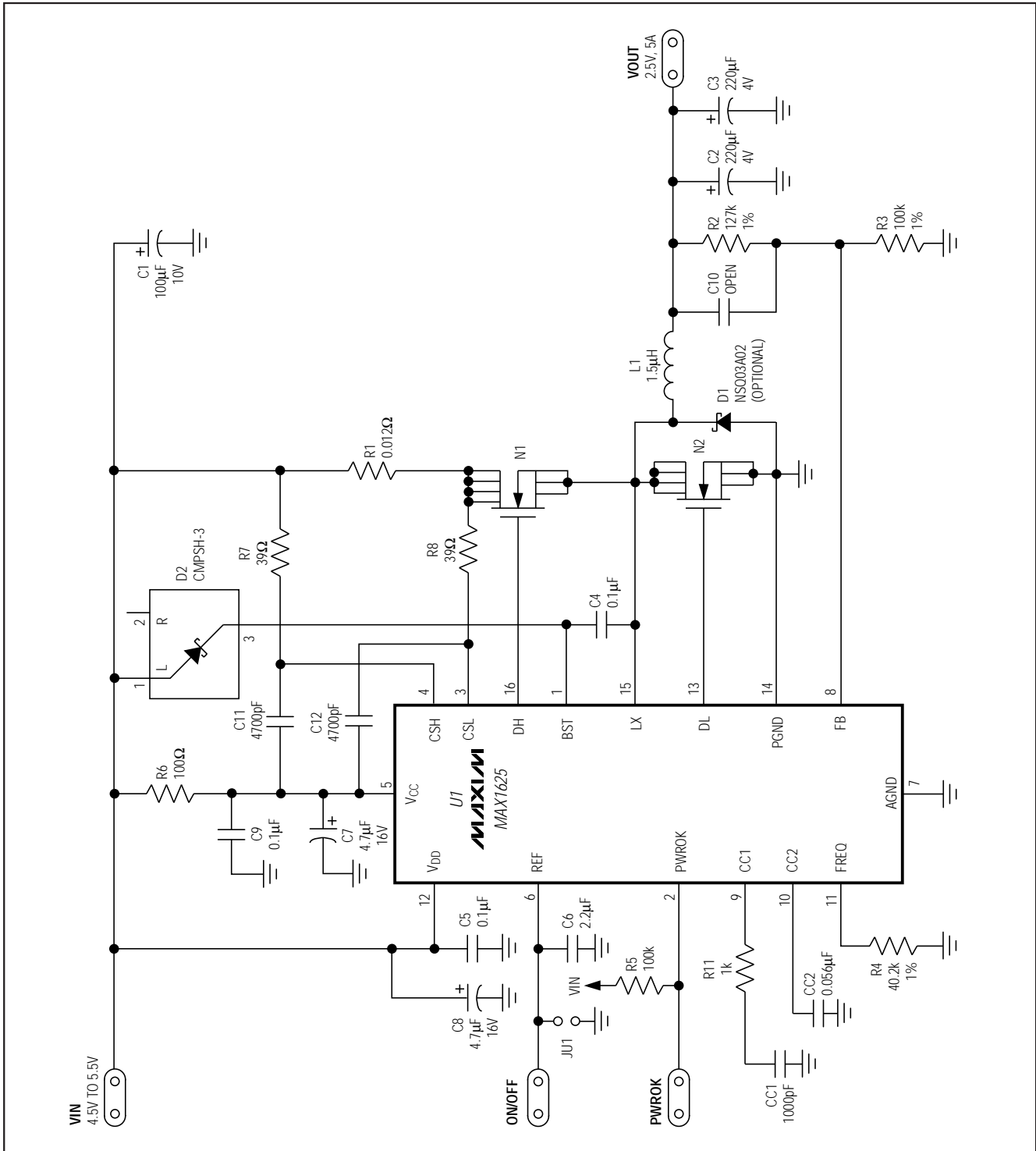

Figure 1. MAX1625 EV Kit Schematic

MAX1625 Evaluation Kit

Evaluates: MAX1625

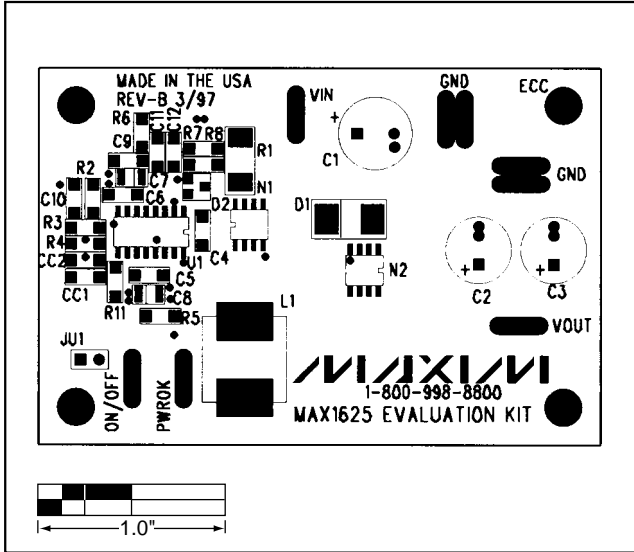

Figure 2. MAX1625 EV Kit Component Placement Guide—Component Side

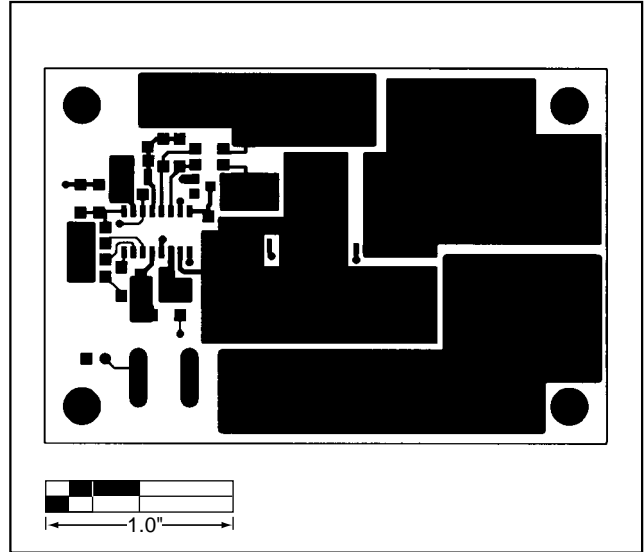

Figure 3. MAX1625 EV Kit PC Board Layout—Component Side

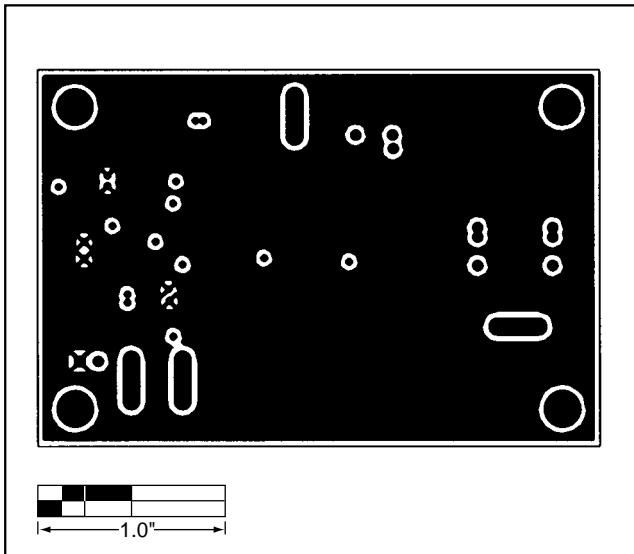

Figure 4. MAX1625 EV Kit PC Board Layout—Two Internal Ground Planes

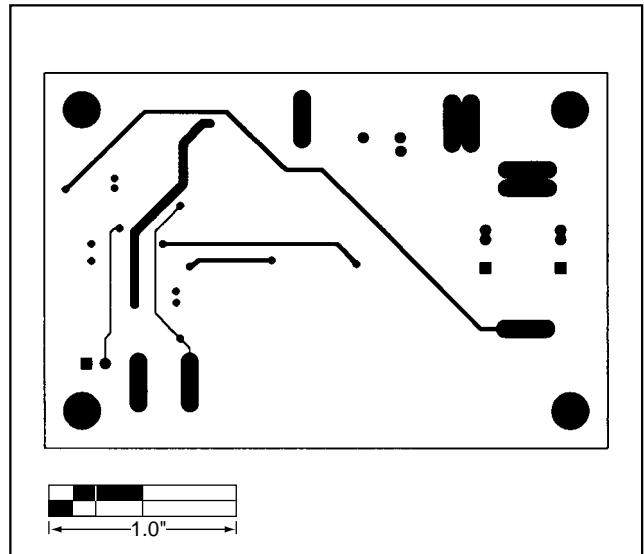

Figure 5. MAX1625 EV Kit PC Board Layout—Solder Side

Maxim cannot assume responsibility for use of any circuitry other than circuitry entirely embodied in a Maxim product. No circuit patent licenses are implied. Maxim reserves the right to change the circuitry and specifications without notice at any time.

4 _____ Maxim Integrated Products, 120 San Gabriel Drive, Sunnyvale, CA 94086 (408) 737-7600

© 1997 Maxim Integrated Products

Printed USA

MAXIM is a registered trademark of Maxim Integrated Products.