

# MAXIM

## MAX1844 Evaluation Kit

**Evaluates: MAX1844**

### General Description

The MAX1844 evaluation kit (EV kit) demonstrates the MAX1844's standard 4A application circuit. This DC-DC converter steps down high-voltage batteries and/or AC adapters, generating a precision, low-voltage rail for use as chipset, DRAM, and other low-voltage supplies.

The MAX1844 EV kit provides a 1.8V output voltage from a 7V to 24V battery input range. It delivers up to 4A output current with greater than 90% efficiency. The EV kit operates at 300kHz switching frequency and has superior line- and load-transient response.

This EV kit is a fully assembled and tested circuit board. It also allows the evaluation of other output voltages in the 1.0V to 5.5V range by changing feedback resistors R1 and R2.

### Features

- ◆ 7V to 24V Input Voltage Range
- ◆ Accurate Current Sense
- ◆ Preset 1.8V/2.5V Output Voltage
- ◆ 1.0V to 5.5V Adjustable Output
- ◆ 4A Output Current
- ◆ 300kHz Switching Frequency
- ◆ Power-Good Output
- ◆ Over/Undervoltage Protection
- ◆ 20-Pin QSOP Package
- ◆ Low-Profile Components
- ◆ Fully Assembled and Tested

### Ordering Information

PART	TEMP. RANGE	IC PACKAGE
MAX1844EVKIT	0°C to +70°C	20 QSOP

### Component List

DESIGNATION	QTY	DESCRIPTION
C1	1	10 $\mu$ F, 25V ceramic capacitor (1812) Taiyo Yuden TMK432BJ106KM or TDK C4532X5R1E106M
C2	1	330 $\mu$ F, 6.3V 40m $\Omega$ low-ESR capacitor Sanyo 6TPB330M
C3	1	0.1 $\mu$ F ceramic capacitor (0805)
C4	1	0.22 $\mu$ F ceramic capacitor (1206)
C5	1	4.7 $\mu$ F, 10V X5R ceramic capacitor (1206) Taiyo Yuden LMK316BJ475ML
C6	1	3.3 $\mu$ F, 10V X5R ceramic capacitor (1206) Taiyo Yuden LMK316BJ335ML
C7	1	2200pF ceramic capacitor (0805)
D1	1	1A Schottky diode Nihon EP10QY03, International Rectifier 10MQ040N, or Nihon EC10QS03
D2	1	100mA, 30V Schottky diode Central Semiconductor CMPSH-3

DESIGNATION	QTY	DESCRIPTION
L1	1	4.7 $\mu$ H power inductor Sumida CDRH124-4R7MC
N1A, N1B	1	Dual N-channel MOSFET Fairchild FDS6982A
R1, R2, R11, R13, R14, R15	0	Not installed (0805)
R3	1	130k $\Omega$ $\pm$ 1% resistor (0805)
R4	1	100k $\Omega$ $\pm$ 5% resistor (0805)
R5, R6	2	1M $\Omega$ $\pm$ 5% resistors (0805)
R7	1	20 $\Omega$ $\pm$ 5% resistor (0805)
R8	1	200 $\Omega$ $\pm$ 5% resistor (0805)
R9	1	274k $\Omega$ $\pm$ 1% resistor (0805)
R10	1	0.015 $\Omega$ $\pm$ 1% 1/2W resistor (2010) IRC LR2010-01-R015-F or Dale WSL-2010-R015F
U1	1	MAX1844EEP (20-pin QSOP)
JU1, JU2	2	2-pin headers
JU9, JU10	2	3-pin headers
None	4	Shunts (JU1, JU2, JU9, JU10)
None	1	MAX1844 PC board
None	1	MAX1844 data sheet
None	1	MAX1844 EV kit data sheet

# MAX1844 Evaluation Kit

## Component Suppliers

SUPPLIER	PHONE	FAX
Central Semiconductor	516-435-1110	516-435-1824
Dale	402-564-3131	402-563-6296
Fairchild	408-721-2181	408-721-1635
IR	310-322-3331	310-252-7175
IRC	361-992-7900	361-992-3377
Nihon	847-843-7500	847-843-2798
Sanyo	619-661-6835	619-661-1055
Sumida	708-956-0666	708-956-0702
Taiyo Yuden	408-573-4150	408-573-4159
TDK	847-390-4373	847-390-4428

**Note:** Please indicate that you are using the MAX1844 when contacting these component suppliers.

## Equipment Needed

- 7V to 24V power supply, battery, or notebook AC adapter
- DC bias power supply, 5V at 100mA
- Dummy load capable of sinking 4A
- Digital multimeter (DMM)
- 100MHz dual-trace oscilloscope

## Quick Start

- 1) Ensure that the circuit is connected correctly to the supplies and dummy load prior to applying any power.
- 2) Verify that the shunts are across JU1, JU2, JU9 pins 1 and 2, and JU10 pins 2 and 3.
- 3) Turn on battery power prior to +5V bias power; otherwise, the output UVLO timer will time out and the FAULT latch will be set, disabling the regulator until +5V power is cycled or shutdown is toggled.
- 4) Observe the 1.8V output with the DMM and/or oscilloscope. Look at the LX switching-node and MOSFET gate-drive signals while varying the load current.

## Detailed Description

### Evaluating Other Output Voltages

The EV kit output is preset to +1.8V. If a 2.5V output is desired, cut the trace shorting JU7 and install a short across R2.

The output voltage can also be adjusted between 1.0V and 5.5V by selecting R1 and R2 values. Cut the PC board trace shorting JU7, then select feedback resistor R2 in the 5kΩ to 50kΩ range. R1 is then given by:

$$R1 = R2 ((V_{OUT} / V_{FB}) - 1)$$

where  $V_{FB} = 1.0V$ . See MAX1844 data sheet for optimizing components for output voltage selection.

## Jumper Settings

**Table 1. Jumper JU1 Functions (Shutdown Mode)**

SHUNT LOCATION	SHDN/PIN	MAX1844 OUTPUT
ON	Connected to VCC	MAX1844 enabled
OFF	Connected to GND	Shutdown mode, $V_{OUT} = 0$

**Table 2. Jumper JU2 Functions (Low-Noise Mode)**

SHUNT LOCATION	SKIP/PIN	OPERATIONAL MODE
ON	Connected to VCC	Low-noise mode, forced fixed-frequency PWM operation.
OFF	Connected to GND	Normal operation, allows automatic PWM/PFM switchover for pulse skipping at light load, resulting in highest efficiency.

**Table 3. Jumper JU3 Functions (Fixed/Adjustable Current-Limit Selection)**

SHUNT LOCATION	ILIM PIN	CURRENT-LIMIT THRESHOLD
ON	Connected to VCC, (remove R3/R9 divider)	100mV
OFF	Connected to REF through voltage-divider R3/R9. Refer to the <i>Current-Limit Circuit</i> section in the MAX1844 data sheet for information on selecting R3/R9.	Adjustable from 25mV to 200mV. Programmed for 65mV by R3 and R9.

# MAX1844 Evaluation Kit

Evaluates: MAX1844

**Table 4. Jumpers JU4, JU5, and JU6 Functions (Switching-Frequency Selection)**

JU4	JU5	JU6	TON PIN	FREQUENCY (kHz)
Not Installed	Not Installed	Not Installed	Floating	300 (as shipped)
Installed	Not Installed	Not Installed	Connected to VCC	200
Not Installed	Installed	Not Installed	Connected to REF	450
Not Installed	Not Installed	Installed	Connected to GND	600

**Important:** Don't change the operating frequency without first recalculating component values. Frequency has a significant effect on preferred inductor value, peak current-limit level, MOSFET heating, PFM/PWM switchover point, output noise, efficiency, and other critical parameters.

**Table 5. Jumper JU7 Functions (Output Voltage Selection)**

JU7	FB PIN	OUTPUT VOLTAGE
Installed	Connected to VCC	$V_{OUT} = 1.8V$ (default)
Not Installed	Connected to GND through R2 (R1 = open)	$V_{OUT} = 2.5V$
Installed	Short on R2	Adjustable from 1V to 5.5V
Not Installed	Connected to resistor-divider R1/R2	Refer to the MAX1844 data sheet for information on setting $V_{OUT}$ in adjustable mode.

**Table 6. Jumper JU8 Functions (Latching/Nonlatching Overvoltage Protection)**

JU8	LATCH PIN	OVP BEHAVIOR
1 and 2	Connected to VCC	Nonlatching
2 and 3	Connected to GND	Latching (default)

**Table 7. Jumper JU9 Functions (Undervoltage Protection Selection)**

JU9	UVP PIN	UVP THRESHOLD
1 and 2	Connected to VCC	UVP is enabled. UVP threshold is 70% of nominal.
2 and 3	Connected to GND	UVP is disabled.
Not Installed	Connected to resistor-divider R14/R15	Refer to the MAX1844 data sheet for information on setting UVP in adjustable mode.

**Table 8. Jumper JU10 Functions (Overvoltage Protection Selection)**

JU10	OVP PIN	OVP THRESHOLD
1 and 2	Connected to VCC	OVP is disabled.
2 and 3	Connected to GND	OVP is enabled. OVP threshold is 114.5% of nominal.
Not Installed	Connected to resistor-divider R13/R11	Refer to the MAX1844 data sheet for information on setting OVP in adjustable mode.

# MAX1844 Evaluation Kit

Evaluates: MAX1844

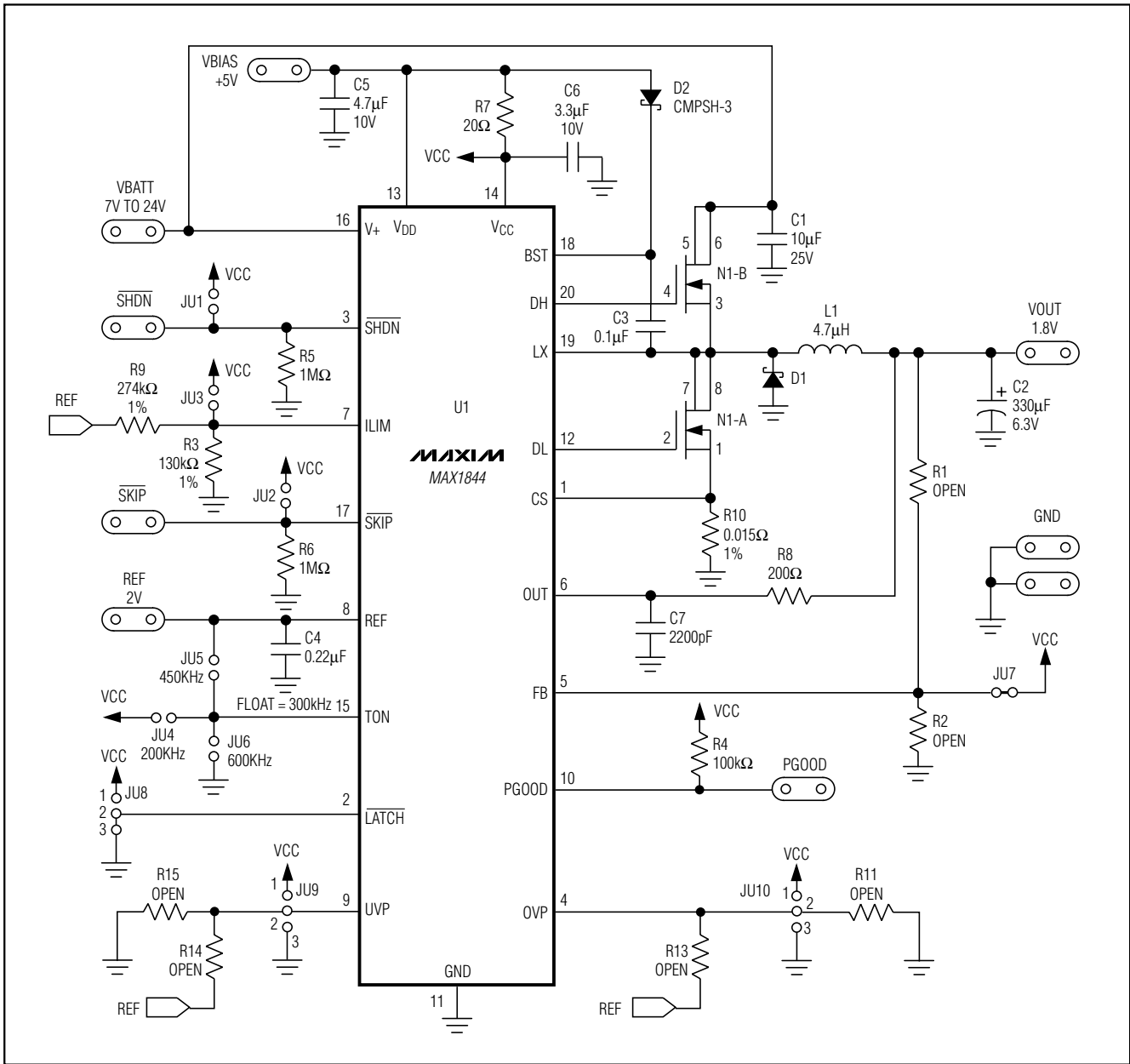

Figure 1. MAX1844 EV Kit Schematic

# MAX1844 Evaluation Kit

Evaluates: MAX1844

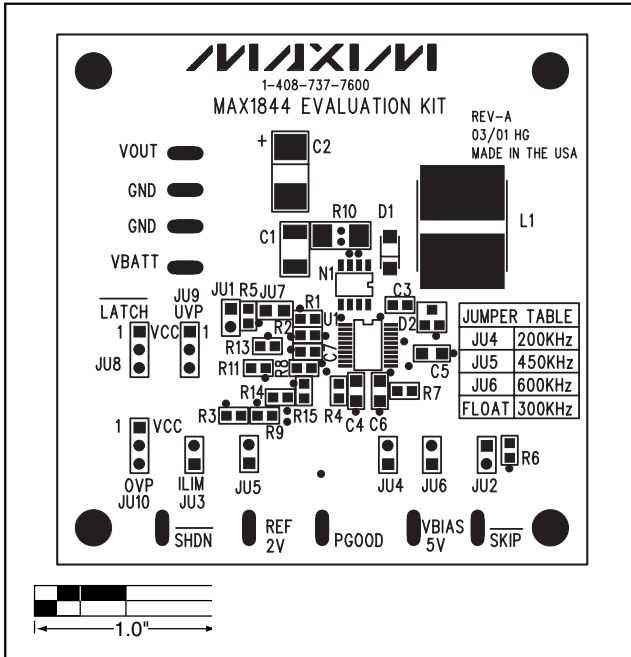

Figure 2. MAX1844 EV Kit Component Placement Guide—Component Side

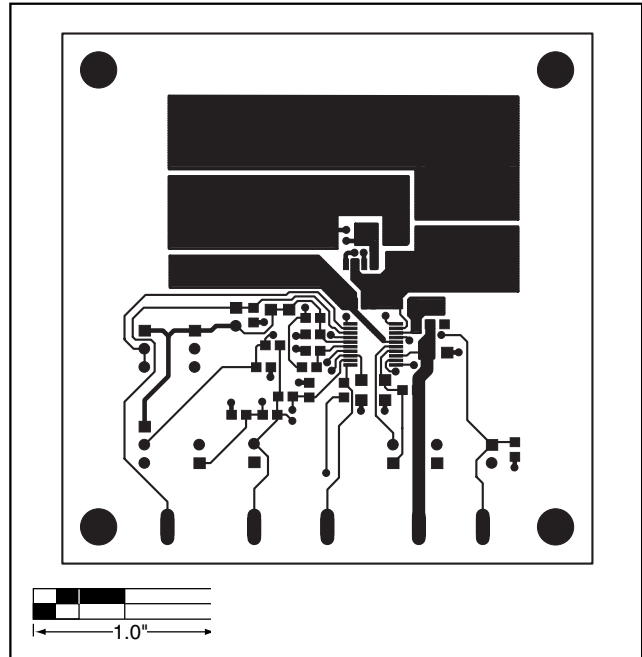

Figure 3. MAX1844 EV Kit PC Board Layout—Component Side

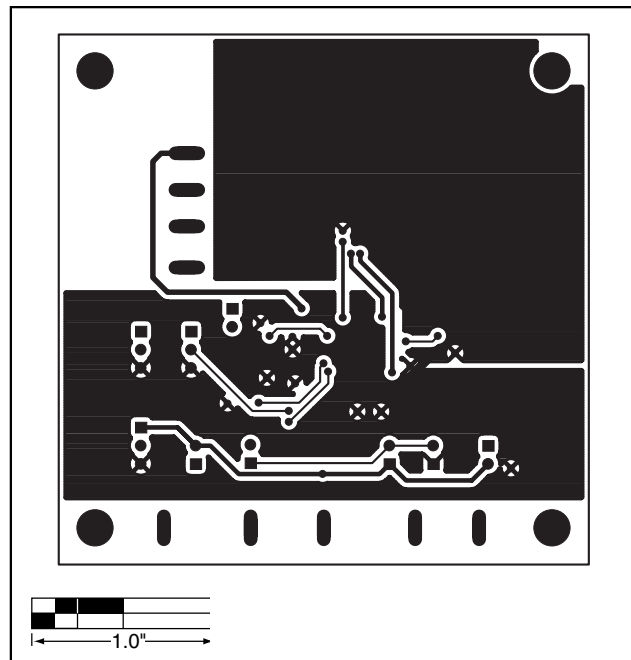

Figure 4. MAX1844 EV Kit PC Board Layout—Solder Side

Maxim cannot assume responsibility for use of any circuitry other than circuitry entirely embodied in a Maxim product. No circuit patent licenses are implied. Maxim reserves the right to change the circuitry and specifications without notice at any time.

Maxim Integrated Products, 120 San Gabriel Drive, Sunnyvale, CA 94086 408-737-7600 5