

MAXIM

MAX1685 Evaluation Kit

General Description

The MAX1685 evaluation kit (EV kit) is a fully assembled and tested surface-mount circuit board that contains a pulse-width-modulated (PWM), step-down DC-DC converter. The EV kit provides a +3.33V output voltage from a +3.5V to +14V input source. It delivers up to 1A output current. The MAX1685 features internal MOSFET switches, low dropout voltage (100% duty-cycle operation), and an accurate +1.25V reference.

The MAX1685 EV kit provides low quiescent current, synchronous rectification, and high efficiency (up to 95%) for maximum battery life. Operation at 600kHz allows the use of a tiny surface-mount inductor.

The MAX1685 EV kit can also be used to evaluate the MAX1684, which operates at 300kHz and has slightly higher efficiency than the MAX1685.

Component List

DESIGNATION	QTY	DESCRIPTION
C1	1	22 μ F, 35V tantalum capacitor AVX TPSE226M035R0300 or Sprague 593D226X0035E2T
C2	1	100 μ F, 10V, low-ESR tantalum capacitor AVX TPSD107M010R0080, Sprague 594D107X0010C2T, or Sanyo 10TPB100M
C3, C4, C5, C9	4	0.1 μ F ceramic capacitors
C6	1	0.01 μ F ceramic capacitor
C7	1	1 μ F, 16V X7R ceramic capacitor Taiyo Yuden EMK316BJ105KL or TDK C3216X7R1C105M
C8	0	Not installed
D1	1	1A Schottky diode Motorola MBRS130LT3, International Rectifier 10BQ040, Nihon EC10QS03, or Nihon EP10QY03
L1	1	10 μ H inductor Sumida CDRH6D28-100NC or Sumida CDRH73-100
R1, R2	0	Not installed
R3, R4	2	100k Ω 5% resistors
U1	1	MAX1685EEE
JU1	1	3-pin header
JU2, JU3	2	2-pin headers
None	1	Shunt (JU1)
None	1	MAX1684/MAX1685 PC board
None	1	MAX1684/MAX1685 data sheet

Features

- ◆ **+3.5V to +14V Input Voltage Range**
- ◆ **Fixed or Adjustable Output Voltage**
+3.33V (Fixed)
+1.25V to V_{IN} (Adjustable)
- ◆ **Guaranteed 1A Output Current**
- ◆ **100% Duty Cycle in Dropout**
- ◆ **600kHz Fixed-Frequency PWM Operation**
- ◆ **Internal MOSFET Switch and Synchronous Rectifier**
- ◆ **2 μ A IC Shutdown Current**
- ◆ **Surface-Mount Components**
- ◆ **Fully Assembled and Tested**

Ordering Information

PART	TEMP. RANGE	IC PACKAGE
MAX1685EVKIT	0°C to +70°C	16-QSOP

Note: To evaluate the MAX1684, request a MAX1684EEE free sample with the MAX1685 EV kit.

Component Suppliers

SUPPLIER	PHONE	FAX
AVX	803-946-0690	803-626-3123
Dale-Vishay	402-564-3131	402-563-6418
International Rectifier	310-322-3331	310-322-3332
Motorola	602-303-5454	602-994-6430
Nihon	661-843-7500	661-843-2798
Sanyo	619-661-6835	619-661-1055
Sprague	603-224-1961	603-224-1430
Sumida	708-956-0666	708-956-0702
TDK	847-390-4373	847-390-4428
Taiyo Yuden	408-573-4150	408-573-4159

Note: Please indicate that you are using the MAX1685 when contacting these component suppliers.



Maxim Integrated Products 1

**For free samples & the latest literature: <http://www.maxim-ic.com>, or phone 1-800-998-8800.
For small orders, phone 1-800-835-8769.**

Evaluates: MAX1684/MAX1685

MAX1685 Evaluation Kit

Quick Start

The MAX1685 EV kit is fully assembled and tested. Follow these steps to verify board operation. **Do not turn on the power supply until all connections are completed.**

- 1) Connect a +3.5V to +14V supply to the VIN pad. Connect ground to the GND pad.
- 2) Connect a voltmeter and load (if any) to the VOUT pad.
- 3) Verify that the shunt is across JU1 pins 1 and 2.
- 4) Turn on the power supply and verify that the output is at +3.33V.

Detailed Description

Jumper Selection

Shutdown Mode

The MAX1685 EV kit features a shutdown mode that reduces the MAX1685's quiescent current to 2 μ A, preserving battery life. The 3-pin header, JU1, selects the shutdown mode (Table 1).

Operating Mode

The MAX1685 operates in one of four modes to optimize performance: a fixed-frequency (PWM) mode switches at a fixed frequency for easy postfiltering; a low-power standby mode; a synchronizable PWM mode that uses an external clock to minimize harmonics; and a normal mode that extends battery life by operating in PWM mode under heavy loads and PFM mode under light loads to reduce power consumption.

Table 1. Jumper JU1 Functions

SHUNT LOCATION	$\overline{\text{SHDN}}$ PIN	MAX1685 OUTPUT
1 & 2	Connected to VIN	MAX1685 enabled, $V_{\text{OUT}} = +3.33\text{V}$
2 & 3	Connected to GND	Shutdown mode, $V_{\text{OUT}} = 0$

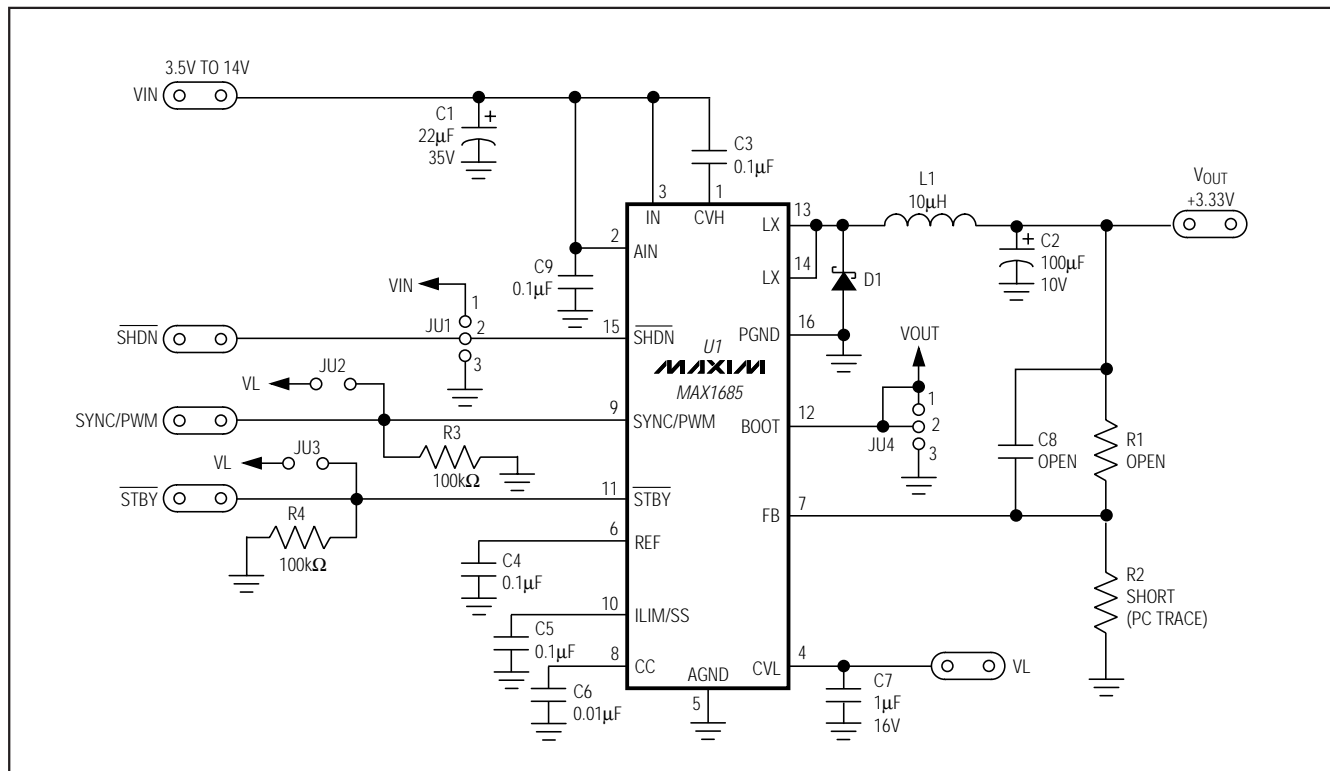

Figure 1. MAX1685 EV Kit Schematic

MAX1685 Evaluation Kit

Evaluates: MAX1684/MAX1685

The EV kit operates at 600kHz switching frequency and allows the use of a tiny inductor. The switching frequency can also be synchronized to an external clock ranging from 360kHz to 700kHz. The 2-pin headers JU2 and JU3 select the operating mode (Tables 2 and 3).

Evaluating Other Output Voltages

The EV kit output is preset to +3.33V. However, the output voltage can also be adjusted between 1.25V and V_{IN} by selecting R1 and R2 values. Select feedback resistor R2 in the 20k Ω to 100k Ω range. R1 is then given by:

$$R1 = R2 [(V_{OUT} / V_{FB}) - 1]$$

where $V_{FB} = 1.25V$. Be sure to cut the PC trace shorting the pads of R2 before installing the resistor. Install a

4.7pF capacitor at location C8. For output voltages greater than +5.5V, cut the trace between pins 1 and 2 of JU4, and short pins 2 and 3 of JU4. Refer to the *Detailed Description* section of the MAX1684/MAX1685 data sheet for further details.

Evaluating the MAX1684

This EV kit can also be used to evaluate the MAX1684. Simply replace the MAX1685 with a MAX1684EEE, and change L1 to a 22 μ H, 1.7A inductor. Refer to the *Inductor Selection* section of the MAX1684/MAX1685 data sheet for more information.

Table 2. Jumper JU2 Functions

SHUNT LOCATION	SYNC/PWM PIN	OPERATING MODE
On	Connected to VL	MAX1685 operates in fixed-frequency mode.
Off (not installed)	Connected to GND	MAX1685 operates in normal mode.
	Driven from external clock	SYNC/PWM pin is driven by an external clock between 360kHz and 700kHz.

Table 3. Jumper JU3 Functions

SHUNT LOCATION	\overline{STBY} PIN	OPERATING MODE
On	Connected to VL	Operation depends on the JU2 setting.
Off (not installed)	Connected to GND	MAX1685 operates in low-power mode. This overrides the JU2 setting.

MAX1685 Evaluation Kit

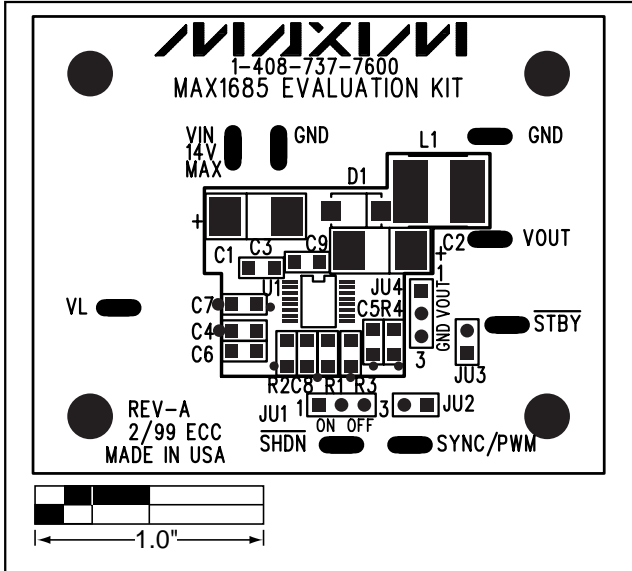

Figure 2. MAX1685 EV Kit Component Placement Guide—Component Side

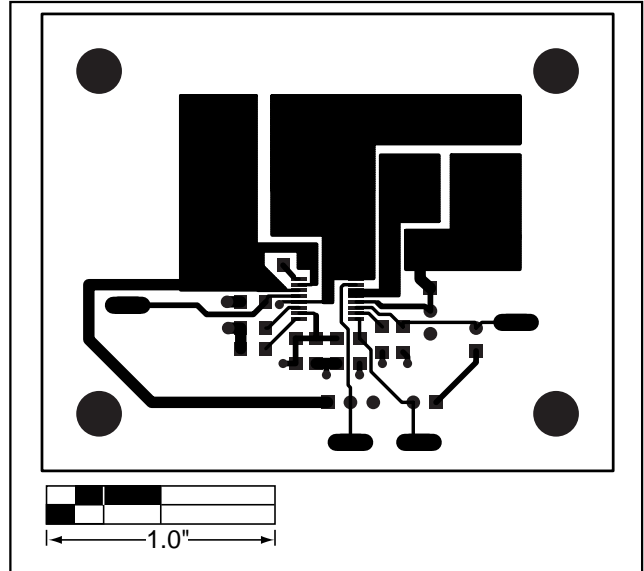

Figure 3. MAX1685 EV Kit PC Board Layout—Component Side

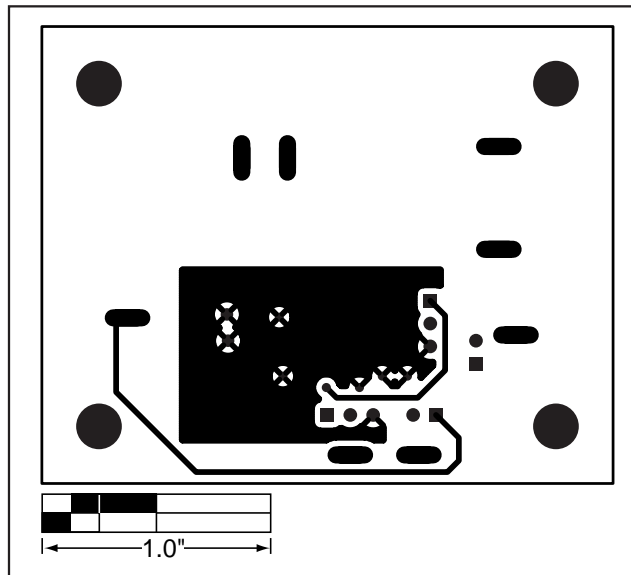

Figure 4. MAX1685 EV Kit PC Board Layout—Solder Side

Maxim cannot assume responsibility for use of any circuitry other than circuitry entirely embodied in a Maxim product. No circuit patent licenses are implied. Maxim reserves the right to change the circuitry and specifications without notice at any time.

4 _____ Maxim Integrated Products, 120 San Gabriel Drive, Sunnyvale, CA 94086 408-737-7600

© 1999 Maxim Integrated Products

Printed USA

MAXIM is a registered trademark of Maxim Integrated Products.