



MAX14529E Evaluation Kit

General Description

The MAX14529E evaluation kit (EV kit) is a fully assembled and tested circuit board that contains all the components necessary to evaluate the MAX14529E IC. The MAX14529E is an overvoltage-protection device with a low dropout (LDO) regulator, ESD protection, and USB charger detection. The EV kit operates from the 5V DC available from the USB VBUS and the 3.3V pullup available from the system input/output voltage (VIO).

Features

- ◆ 5V Supply Operation from USB VBUS
- ◆ 3.3V Pullup from Application System's VIO or VPU
- ◆ 5.75V Overvoltage-Protection Trip Level
- ◆ 100mA, 3.3V LDO Output
- ◆ High-Current USB Charger Detection
- ◆ Evaluates the MAX14529E in 12-Bump WLP Package
- ◆ Fully Assembled and Tested

Ordering Information

PART	TYPE
MAX14529EEVKIT+	EV Kit

+Denotes lead(Pb)-free and RoHS compliant.

Component List

DESIGNATION	QTY	DESCRIPTION
C1	1	1 μ F \pm 10%, 50V X7R ceramic capacitor (1206) Murata GRM31MR71H105K or TDK C3216X7R1H105K
C2	1	1 μ F \pm 10%, 10V X5R ceramic capacitor (0603) Murata GRM188R61A105K or TDK C1608X5R1A105K
C3	1	0.1 μ F \pm 10%, 50V X7R ceramic capacitor (0603) Murata GRM188R71H104K or TDK C1608X7R1H104K

DESIGNATION	QTY	DESCRIPTION
JU1, JU2	2	3-pin headers
JU3, JU4	2	2-pin headers
P1	1	USB type-AB right-angle mini jack
R1–R4	4	10k Ω \pm 5% resistors (0603)
R5	1	1.5k Ω \pm 5% resistor (0603)
U1	1	Overvoltage protector (12 WLP) Maxim MAX14529EEWC+ (Top Mark: AAP)
—	4	Shunts (JU1–JU4)
—	1	PCB: MAX14529E EVALUATION KIT+

Component Suppliers

SUPPLIER	PHONE	WEBSITE
Murata Electronics North America, Inc.	770-436-1300	www.murata-northamerica.com
TDK Corp.	847-803-6100	www.component.tdk.com

Note: Indicate that you are using the MAX14529E when contacting these component suppliers.



For pricing, delivery, and ordering information, please contact Maxim Direct at 1-888-629-4642, or visit Maxim's website at www.maxim-ic.com.

MAX14529E Evaluation Kit

Quick Start

Required Equipment

- MAX14529E EV kit
- 2.2V to 6V, 100mA DC power supply (VBUS)
- 3.3V, 100mA DC power supply for +3V3
- Voltmeter

Procedure

The MAX14529E EV kit is fully assembled and tested. Follow the steps below to verify board operation.

Caution: Do not turn on the power supply until all connections are completed.

- 1) Verify that a shunt is installed on pins 2-3 of jumper JU1 (overvoltage protection enabled).
- 2) Verify that a shunt is installed on pins 2-3 of jumper JU2 (low dropout enabled).
- 3) Verify that a shunt is not installed on jumper JU3 (VPU not connected to +3V3).
- 4) Verify that a shunt is not installed on jumper JU4 (no charger connected).
- 5) Set the VBUS power supply to provide 5V and disable the power supply.
- 6) Set the +3V3 power supply to 3.3V and disable the power supply.
- 7) Connect the VBUS power-supply positive terminal to the VBUS PCB pad.
- 8) Connect the VBUS power-supply ground to the GND PCB pad (near the VBUS PCB pad).
- 9) Connect the +3V3 power-supply positive terminal to the +3V3 PCB pad.
- 10) Connect the +3V3 power-supply ground to the GND PCB pad (any nearby GND PCB pad).
- 11) Enable both power supplies.
- 12) Verify that the OUT PCB pad is at 5V.
- 13) Verify that the LOUT PCB pad is at 3.3V.
- 14) Verify that the \overline{VOK} PCB pad is at 0V.
- 15) Connect the D- PCB pad to ground, and verify that the \overline{CDET} PCB pad is at 3.3V.
- 16) Disconnect the D- PCB pad from ground, and install a shunt on jumper JU3 (VPU connected to +3V3).
- 17) Install a shunt on jumper JU4 (D- connected to D+, simulate charger connected).

- 18) Verify that the \overline{CDET} PCB pad is at 0V.
- 19) Increase the VBUS power-supply output to 6V.
- 20) Verify that the \overline{VOK} PCB pad is at 3.3V.
- 21) Verify that the OUT PCB pad is at 0V.
- 22) Verify that the LOUT PCB pad is at 0V.

Detailed Description of Hardware

The MAX14529E EV kit contains the MAX14529E, an overvoltage-protection device with a low dropout (LDO) regulator, ESD protection, and USB charger detection. The EV kit operates from the 5V DC available from the USB VBUS. The EV kit's logic inputs and outputs can be pulled up by the input/output voltage (VIO) available from the application system.

Application System Interface

The MAX14529E EV kit features a USB jack and PCB pads that allow convenient interfacing between the USB port and the application system. Connect the USB cable to the USB type-AB mini jack on the MAX14529E EV kit. Connect the system charger to the OUT and GND PCB pads. Connect the USB transceiver signals to the D+ and D- PCB pads, and the USB transceiver input/output voltage (VIO or VPU) to the VPU PCB pad. Connect the USB transceiver \overline{VCC} to the LOUT PCB pad. Connect the \overline{OEN} , \overline{LEN} , \overline{VOK} , and \overline{CDET} PCB pads to the appropriate locations in the system micro-processor circuit.

Jumper Selection

Overvoltage-Protection Enable, \overline{OEN} (JU1)

The MAX14529E EV kit provides jumper JU1 to enable or disable the overvoltage-protection function in the MAX14529E IC, thus preventing damage to the protected components. Table 1 lists the options to enable or disable the overvoltage-protection function in the MAX14529E IC.

Table 1. JU1 Jumper Functions (\overline{OEN})

SHUNT POSITION	\overline{OEN} PIN CONNECTED TO	MAX14529E OVERVOLTAGE PROTECTION
1-2	+3V3 (through resistor R1)	Disabled
2-3*	GND	Enabled

*Default position.

MAX14529E Evaluation Kit

Evaluates: MAX14529E

Table 2. JU2 Jumper Functions (\overline{LEN})

SHUNT POSITION	\overline{LEN} PIN CONNECTED TO	MAX14529E LDO REGULATOR OUTPUT
1-2	+3V3 (through resistor R2)	Disabled
2-3*	GND	Enabled

*Default position.

Table 3. JU3 Jumper Functions (VPU and +3V3)

SHUNT POSITION	VPU PAD AND +3V3 PAD	CHARGER SIMULATION PULLUP (VPU) CONNECTED TO
Installed	Connected	+3V3
Not installed*	Not connected	External pullup voltage required for VPU

*Default position.

Table 4. JU4 Jumper Functions (D- and D+)

SHUNT POSITION	D- AND D+ PAD	CHARGER SIMULATION MODE
Installed	Connected	Charger connected
Not installed*	Not connected	No charger connected

*Default position.

Low Dropout Enable, \overline{LEN} (JU2)

The MAX14529E EV kit provides jumper JU2 to enable or disable the LDO regulator in the MAX14529E IC. Table 2 lists the options to enable or disable the LDO regulator in the MAX14529E IC.

Charger Simulation Pullup Voltage, VPU (JU3)

The MAX14529E EV kit provides jumper JU3 to connect the charger simulation pullup voltage (VPU) to the MAX14529E EV kit pullup voltage (3.3V). Table 3 lists the jumper options for jumper JU3.

Charger Simulation Mode, D- and D+ (JU4)

The MAX14529E EV kit provides jumper JU4 to short the USB D- and D+ data lines that simulate a charger-connected condition. Table 4 lists the jumper options for jumper JU4.

MAX14529E Evaluation Kit

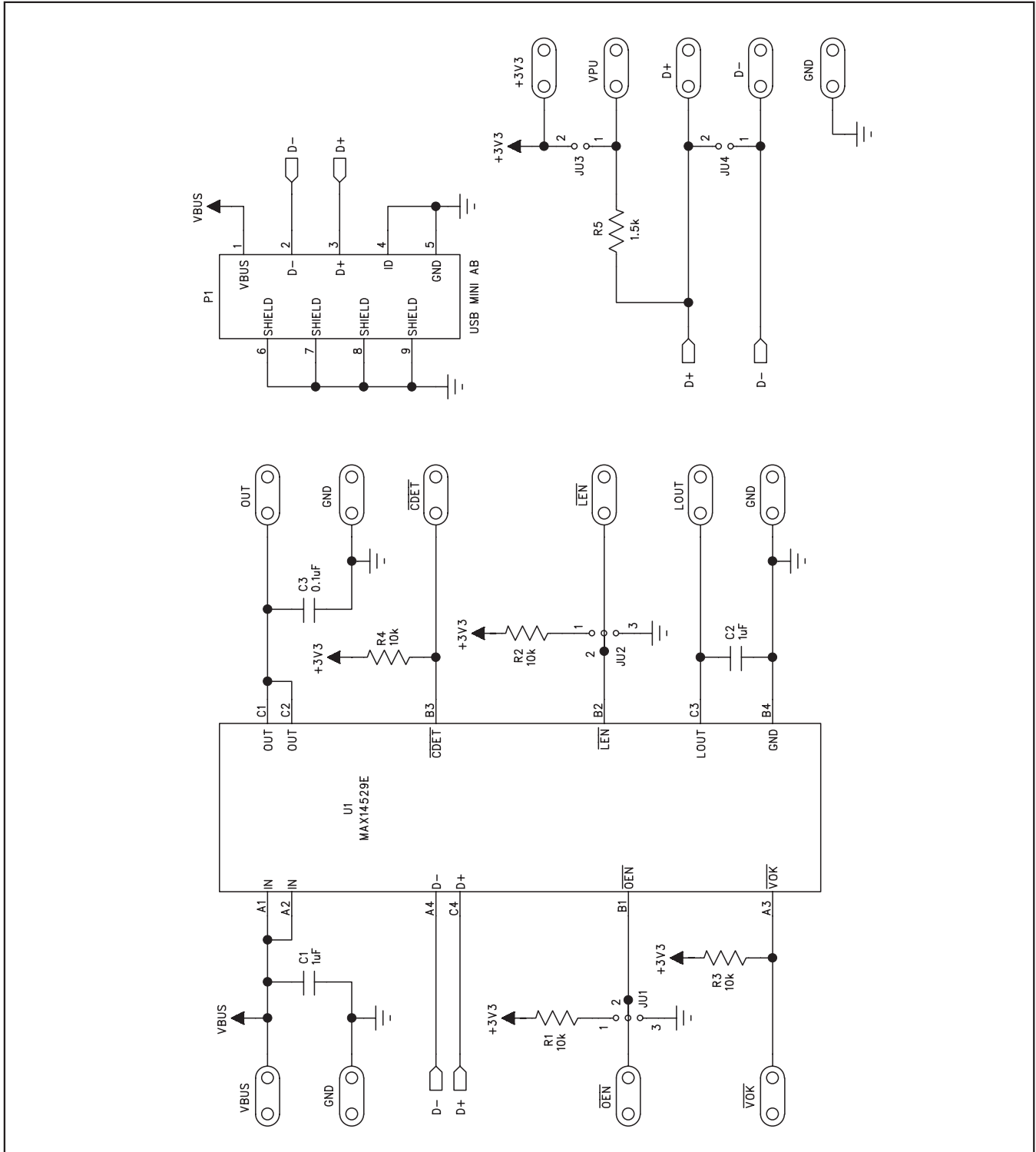

Figure 1. MAX14529E EV Kit Schematic

MAX14529E Evaluation Kit

Evaluates: MAX14529E

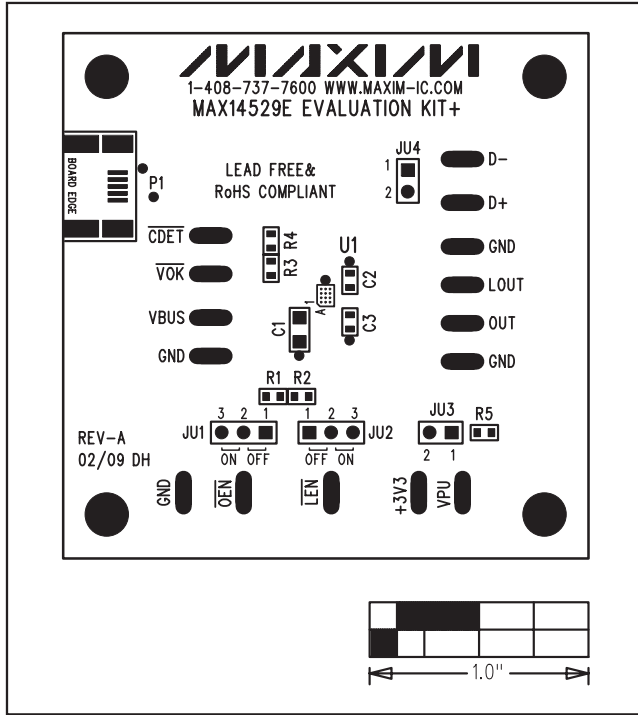

Figure 2. MAX14529E EV Kit Component Placement Guide—Component Side

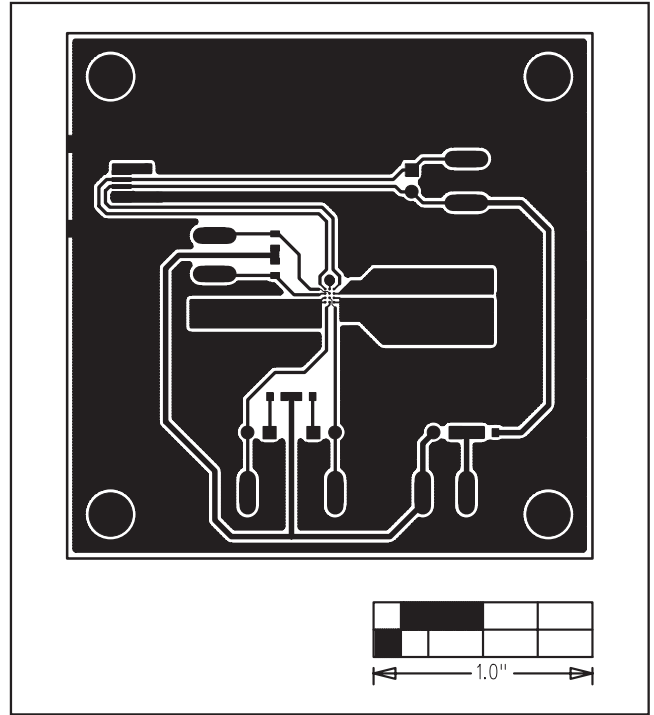

Figure 3. MAX14529E EV Kit PCB Layout—Component Side

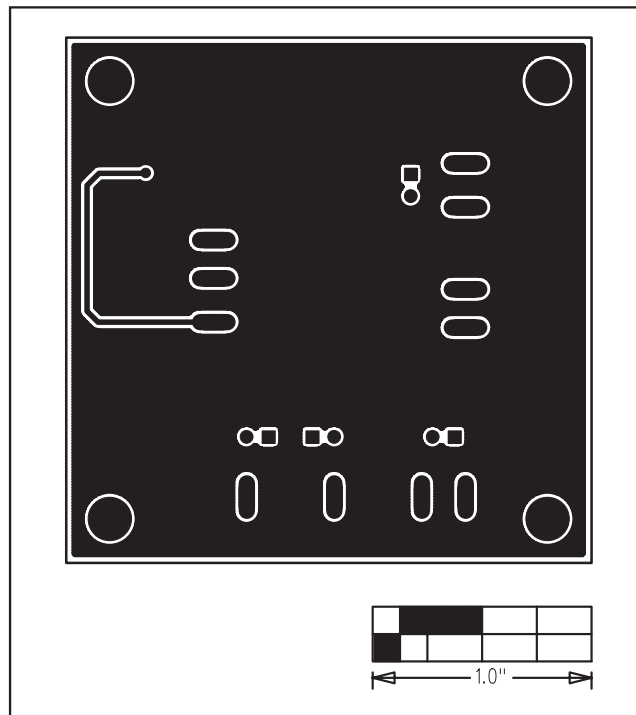

Figure 4. MAX14529E EV Kit PCB Layout—Solder Side

MAX14529E Evaluation Kit

Revision History

REVISION NUMBER	REVISION DATE	DESCRIPTION	PAGES CHANGED
0	3/00	Initial release	—
1	11/09	Revised steps 15 and 16 in the <i>Quick Start</i> section	2

Maxim cannot assume responsibility for use of any circuitry other than circuitry entirely embodied in a Maxim product. No circuit patent licenses are implied. Maxim reserves the right to change the circuitry and specifications without notice at any time.

6 **Maxim Integrated Products, 120 San Gabriel Drive, Sunnyvale, CA 94086 408-737-7600**

© 2009 Maxim Integrated Products

Maxim is a registered trademark of Maxim Integrated Products, Inc.