

General Description

The MAX5048C evaluation kit (EV kit) allows evaluation of the MAX5048C high-speed, low-side MOSFET driver that can source up to a 3A peak current and sink up to a 7A peak current. The EV kit uses a 4V to 14V input supply. The EV kit uses the device to drive a 4700pF capacitor that mimics the gate capacitance of an external nMOSFET. The EV kit demonstrates the MAX5048CAUT+ (6-pin SOT23). It is highly recommended that the EV kit layout be followed to ensure reliable driver operation and first-pass design success.

Features

- 4V to 14V Single Power-Supply Range
- 3A/7A Peak Source/Sink Drive Current
- TTL Logic Level Inverting and Noninverting Inputs
- Independent Source and Sink Outputs
- Proven PCB Layout
- Fully Assembled and Tested

Ordering Information appears at end of data sheet.

Component List

DESIGNATION	QTY	DESCRIPTION
C1	1	10µF ±20%, 25V electrolytic capacitor (4.30mm x 4.30mm SMD) Panasonic EEEFK1E100R
C2	1	1µF ±10%, 25V X7R ceramic capacitor (0805) Murata GRM21BR71E105K
C3	1	4700pF ±10%, 50V X7R ceramic capacitor (0603) Murata GRM188R71H472K

DESIGNATION	QTY	DESCRIPTION
R1, R2	2	0Ω resistors (0603)
U1	1	High-speed MOSFET driver (6 SOT23) Maxim MAX5048CAUT+
—	1	PCB: MAX5048C EVALUATION KIT

Component Suppliers

SUPPLIER	PHONE	WEBSITE
Murata Electronics North America, Inc.	770-436-1300	www.murata-northamerica.com
Panasonic Corp.	800-344-2112	www.panasonic.com

Note: Indicate that you are using the MAX5048C when contacting these component suppliers.

Quick Start

Required Equipment

- MAX5048C EV kit
- 4V to 14V DC power supply

Procedure

The EV kit is fully assembled and tested. Follow the steps below to verify board operation. **Caution: Do not turn on the power supply until all connections are completed.**

- 1) Connect the positive terminal of the power supply to the V+ PCB connector and the negative terminal to the nearest GND PCB connector on the EV kit.
- 2) Set the V+ power supply to 5V.
- 3) Drive IN+, IN-, and verify states per Table 1.
- 4) Repeat accordingly for the other circuits.

Detailed Description of Hardware

The MAX5048C EV kit operates on a 4V to 14V wide-input voltage range and sources 3A peak current/sinks 7A peak current.

Inverting (IN-) and Noninverting (IN+) Logic Inputs

The EV kit has independent inverting and noninverting TTL logic inputs. These inputs control the P_OUT and N_OUT states, as shown in Table 1.

Power-Supply Input (V+)

The EV kit operates from 4V to +14V power supply.

Table 1. Truth Table

IN+	IN-	P_OUT	N_OUT
L	L	Off	On
L	H	Off	On
H	L	On	Off
H	H	Off	On

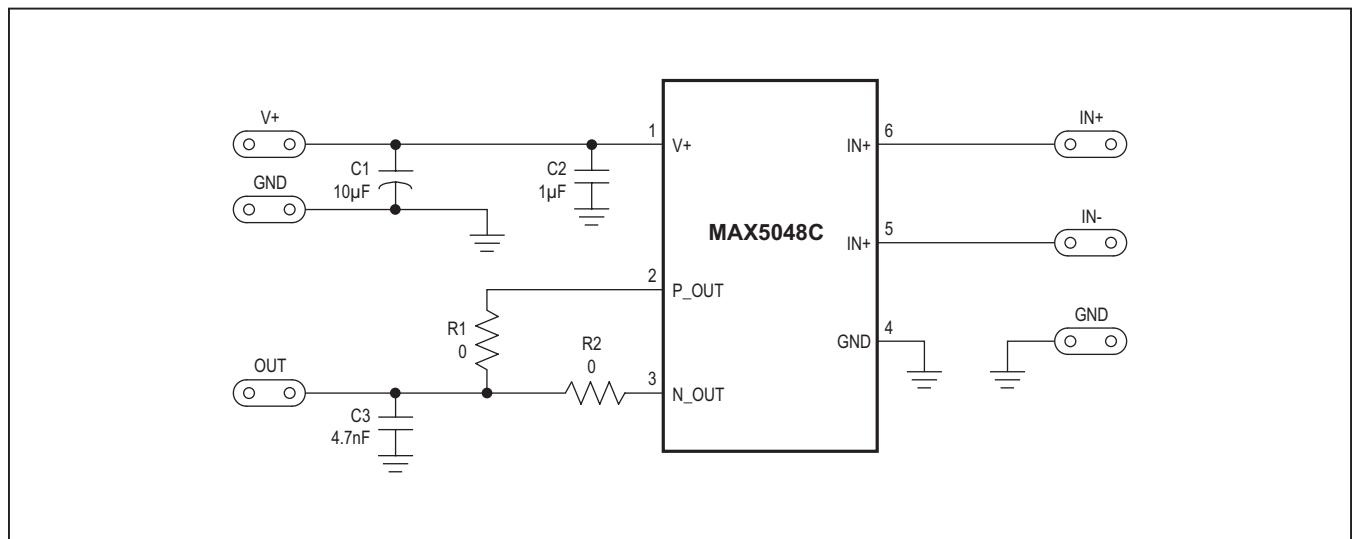

Figure 1. MAX5048C EV Kit Schematic

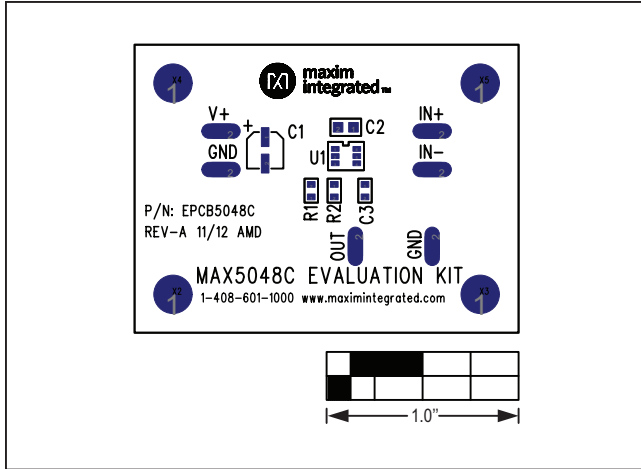

Figure 2. MAX5048C EV Kit Component Placement—Component Side

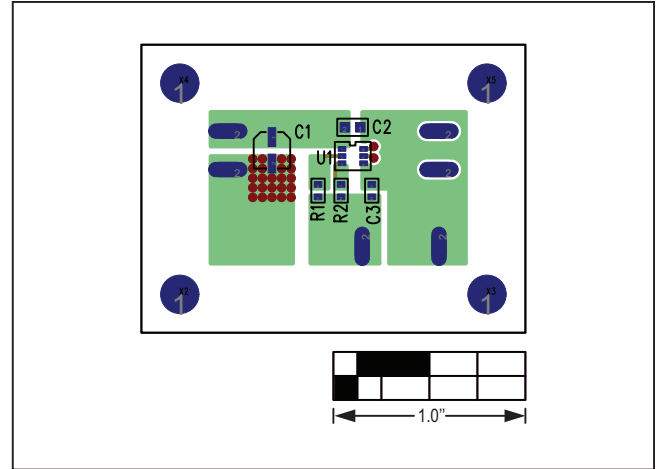

Figure 3. MAX5048C EV Kit PCB Layout—Component Side

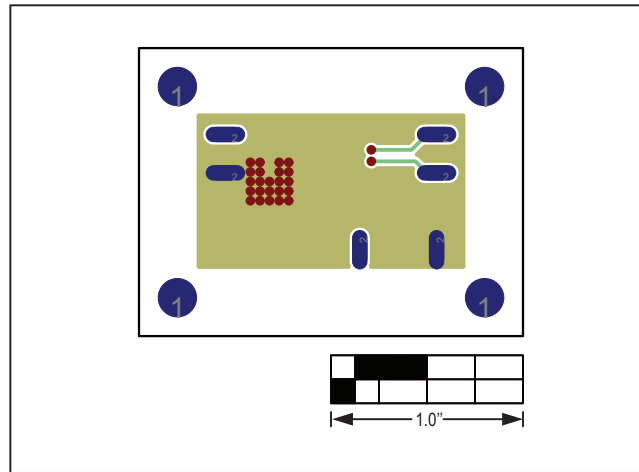

Figure 4. MAX5048C EV Kit PCB Layout—Solder Side

Ordering Information

PART	TYPE
MAX5048CEVKIT#	EV Kit

#Denotes RoHS compliant.

Revision History

REVISION NUMBER	REVISION DATE	DESCRIPTION	PAGES CHANGED
0	1/13	Initial release	—

For pricing, delivery, and ordering information, please contact Maxim Direct at 1-888-629-4642, or visit Maxim Integrated's website at www.maximintegrated.com.

Maxim Integrated cannot assume responsibility for use of any circuitry other than circuitry entirely embodied in a Maxim Integrated product. No circuit patent licenses are implied. Maxim Integrated reserves the right to change the circuitry and specifications without notice at any time.