



MAX5976B Evaluation Kit

General Description

The MAX5976B evaluation kit (EV kit) provides a proven design to evaluate the MAX5976B hot-swap controller with an integrated 7A MOSFET. The EV kit is configured to pass 7A into a 2.7V to 18V hot-swap application, thus providing a fully integrated solution. The EV kit uses the MAX5976BETE+ in a 5mm x 5mm x 0.8mm, 16-pin TQFN package on a proven four-layer PCB design.

The EV kit can also be used to evaluate the MAX5976A after IC replacement of U1.

Features

- ◆ 2.7V to 18V Operating-Voltage Range
- ◆ Up to 7A Configurable Load-Current Capability
- ◆ Banana Jacks for Input and Output Voltage
- ◆ Selectable/Configurable Circuit-Breaker Threshold
- ◆ Selectable/Configurable Undervoltage Lockout
- ◆ Fault and Power-Good LED Indicators
- ◆ Slide Switches and Input Pads for Enable Inputs
- ◆ Proven PCB Layout
- ◆ Fully Assembled and Tested

Ordering Information

PART	TYPE
MAX5976BEVKIT+	EV Kit

+Denotes lead(Pb)-free and RoHS compliant.

Component List

DESIGNATION	QTY	DESCRIPTION
C1	1	1 μ F \pm 10%, 25V X7R ceramic capacitor (0603) Murata GRM188R71E105K
C2, C3, C4	3	10 μ F \pm 20%, 25V X5R ceramic capacitors (1206) Murata GRM31CR61E106M
C5	1	1000pF \pm 10%, 50V X7R ceramic capacitor (0603) Murata GRM188R71H102K
C6	0	Not installed, capacitor (1206)
D1	1	18V, 600W transient voltage suppressor (SMB) Fairchild SMBJ18A
D2	1	20V, 1A Schottky rectifier (SMA) Fairchild SS12
D3	1	5.1V, 250mA zener diode (SOT23) Fairchild BZX84C5V1
D4	1	Green LED (1206)
D5	1	Red LED (1206)
FAULT, PG, REG	3	Test points, white
GND	2	Test points, black

DESIGNATION	QTY	DESCRIPTION
GND (x2), VIN, VOUT	4	Uninsulated banana jacks, panel mount
JU1	1	3-pin header
JU2	1	2-pin header
N1	1	60V, 115mA n-channel MOSFET (SOT23) Fairchild 2N7002
P1	1	-60V, -0.18A, p-channel MOSFET (SOT23) Fairchild NDS0605
R1–R5	5	100k Ω \pm 5% resistors (0603)
R6, R7	2	1k Ω \pm 5% resistors (0805)
R8	1	40.2k Ω \pm 1% resistor (0805)
R9	1	50k Ω SMT cermet trimmer
R10	0	Not installed, resistor (0603)
SW1, SW2, SW3	3	SPDT slide switches, 2.5mm centers
U1	1	Hot-swap controller (16 TQFN-EP*) Maxim MAX5976BETE+
—	2	Shunts
—	1	PCB: MAX5976B EVALUATION KIT+

*EP = Exposed pad.



MAX5976B Evaluation Kit

Component Suppliers

SUPPLIER	PHONE	WEBSITE
Fairchild Semiconductor	888-522-5372	www.fairchildsemi.com
Murata Electronics North America, Inc.	770-436-1300	www.murata-northamerica.com

Note: Indicate that you are using the MAX5976B when contacting these component suppliers.

Quick Start

Required Equipment

- MAX5976B EV kit
- 12V, 10A DC power supply
- Voltmeter

Procedure

The EV kit is fully assembled and tested. Follow the steps below to verify board operation. **Caution: Do not turn on the power supply until all connections are completed.**

- 1) Verify that shunts are installed in their default position for jumpers JU1 and JU2, as shown in Table 1.
- 2) Verify that slide switches SW1, SW2, and SW3 are set in their default position, as shown in Table 2.
- 3) Turn on the power supply and set the supply to 12V, then disable the power supply.
- 4) Connect the positive terminal of the power supply to the VIN banana jack on the EV kit. Connect the negative terminal of the power supply to the GND banana jack.
- 5) Enable the power supply.
- 6) Verify that the voltage between the OUT and GND banana jacks is 12V.
- 7) Verify that the voltage at the internal regulator voltage test point (REG) is 2.6V.
- 8) The EV kit is now ready for additional evaluation.

Detailed Description of Hardware

The MAX5976B EV kit provides a proven design to evaluate the MAX5976B hot-swap controller with an integrated 7A MOSFET. The EV kit can be conveniently connected between the system power and the load using the banana jacks provided for the input and output voltage. PCB pads are provided to monitor and control the device signals. The EV kit operates between 2.7V and 18V with up to 7A load-current capability.

Evaluating the MAX5976A

The EV kit can also be used to evaluate the MAX5976A after IC replacement of U1 with the MAX5976AETE+. The MAX5976A is pin-to-pin compatible with the MAX5976B. Refer to the MAX5976A/MAX5976B IC data sheet for details on the MAX5976A.

Table 1. Default Shunt Positions (JU1, JU2)

JUMPER	SHUNT POSITION	MAX5976B PIN	EV KIT FUNCTION
JU1	1-2	CB to GND (through resistor R8)	Current limit is set to 7A.
JU2	Installed	ON1 to VIN (through resistor R1)	Undervoltage-lockout threshold is set to 2.5V.

Table 2. Default Switch Positions (SW1, SW2, SW3)

SWITCH	SWITCH POSITION	MAX5976B PIN	EV KIT OUTPUT
SW1	1-2	ON1 to VIN (through resistor R1 and jumper JU2)	Enabled
SW2	2-3	ON2 to GND	
SW3	2-3	PRESDT to GND	

Jumper Selection

Circuit Breaker (CB)

Jumper JU1 sets the current limit for the internal circuit breaker (CB) of the device. The CB pin can be connected to a fixed resistor (R8) or a potentiometer (R9) to set the current limit. See Table 3 for shunt positions.

Undervoltage Lockout (ON1)

The EV kit provides an option to configure the undervoltage-lockout threshold. The undervoltage-lockout threshold for the device is configured by the VIN voltage level divided by R1 and R10 at the ON1 pin. Set slide switch SW1 to position 1-2 before configuring the undervoltage-lockout threshold. See Table 4 for JU2 shunt positions.

Slide Switches

Active-High Enable (ON1)

Slide switch SW1 controls the active-high enable pin (ON1) on the device. See Table 5 for switch positions.

MAX5976B Evaluation Kit

Evaluates: MAX5976A/MAX5976B

Table 3. JU1 Jumper Selection (CB)

SHUNT POSITION	CB PIN CONNECTED TO	CURRENT LIMIT
1-2*	R8	7A
2-3	R9	$I_{LIMIT} = \left(\frac{0.175A}{1000\Omega}\right) \times R9$
Not installed	Not connected	Not allowed

*Default position.

Table 4. JU2 Jumper Selection (ON1)

SHUNT POSITION	ON1 PIN CONNECTED TO	UNDERVOLTAGE-LOCKOUT THRESHOLD
Installed*	VIN (through jumper JU2 and resistor-dividers R1 and R10). Note: Set SW1 to pins 1-2 before installing a shunt on JU2.	$V_{UVLO} = 2.5V$ where: R10 = open*
		$V_{UVLO} = \left(\frac{R1}{R10} + 1\right) \times 1.21V$ where: R1 = 100k Ω R10 = 7.5k Ω to 86.6k Ω
Not installed	External voltage signal is connected to the ON1 PCB pad. Note: Set SW1 to pins 1-2 and remove the shunt on JU2 before connecting an external voltage signal to the ON1 PCB pad.	Enabled: <ul style="list-style-type: none"> • $V_{ON1} \geq 1.21V$ • $VIN \geq V_{UVLO}$ • $\overline{ON2}$ asserted low • \overline{PRESDT} asserted low
		Disabled: <ul style="list-style-type: none"> • $V_{ON1} < 1.21V$

*Default position.

Table 5. SW1 Switch Positions (ON1)

SWITCH POSITION	ON1 PIN CONNECTED TO	EV KIT FUNCTION
1-2*	VIN (through resistor R1 and jumper JU2). Note: Install a shunt on jumper JU2.	Enabled: <ul style="list-style-type: none"> • $VIN \geq V_{UVLO}$ • $\overline{ON2}$ asserted low • \overline{PRESDT} asserted low
	External voltage signal is connected to the ON1 PCB pad. Note: Remove the shunt on jumper JU2.	Enabled: <ul style="list-style-type: none"> • $V_{ON1} \geq 1.21V$ • $VIN \geq V_{UVLO}$ • $\overline{ON2}$ asserted low • \overline{PRESDT} asserted low
		Disabled: <ul style="list-style-type: none"> • $V_{ON1} < 1.21V$
2-3	GND	Disabled

*Default position.

MAX5976B Evaluation Kit

Evaluates: MAX5976A/MAX5976B

Active-Low Enable ($\overline{ON2}$)

Slide switch SW2 controls the active-low enable pin ($\overline{ON2}$) on the device. See Table 6 for switch positions.

Present Detect ($\overline{PRESD\overline{ET}}$)

Slide switch SW3 controls the present-detect pin ($\overline{PRESD\overline{ET}}$) on the device. See Table 7 for switch positions.

Table 6. SW2 Switch Positions ($\overline{ON2}$)

SWITCH POSITION	$\overline{ON2}$ PIN CONNECTED TO	EV KIT FUNCTION
1-2	VIN (through pullup resistor R2).	Disabled
	External TTL signal is connected to the $\overline{ON2}$ PCB pad.	Disabled: <ul style="list-style-type: none"> TTL logic-high Enabled <ul style="list-style-type: none"> TTL logic-low VIN ≥ VUVLO ON1 asserted high $\overline{PRESD\overline{ET}}$ asserted low
2-3*	GND	Enabled <ul style="list-style-type: none"> VIN ≥ VUVLO ON1 asserted high $\overline{PRESD\overline{ET}}$ asserted low

*Default position.

Table 7. SW3 Switch Positions ($\overline{PRESD\overline{ET}}$)

SWITCH POSITION	$\overline{PRESD\overline{ET}}$ PIN CONNECTED TO	EV KIT FUNCTION
1-2	VIN (through pullup resistor R3).	Disabled
	External TTL signal is connected to the $\overline{PRESD\overline{ET}}$ PCB pad.	Disabled: <ul style="list-style-type: none"> TTL logic-high Enabled: <ul style="list-style-type: none"> TTL logic-low VIN ≥ VUVLO ON1 asserted high $\overline{ON2}$ asserted low
2-3*	GND	Enabled: <ul style="list-style-type: none"> VIN ≥ VUVLO ON1 asserted high $\overline{ON2}$ asserted low

*Default position.

MAX5976B Evaluation Kit

Evaluates: MAX5976A/MAX5976B

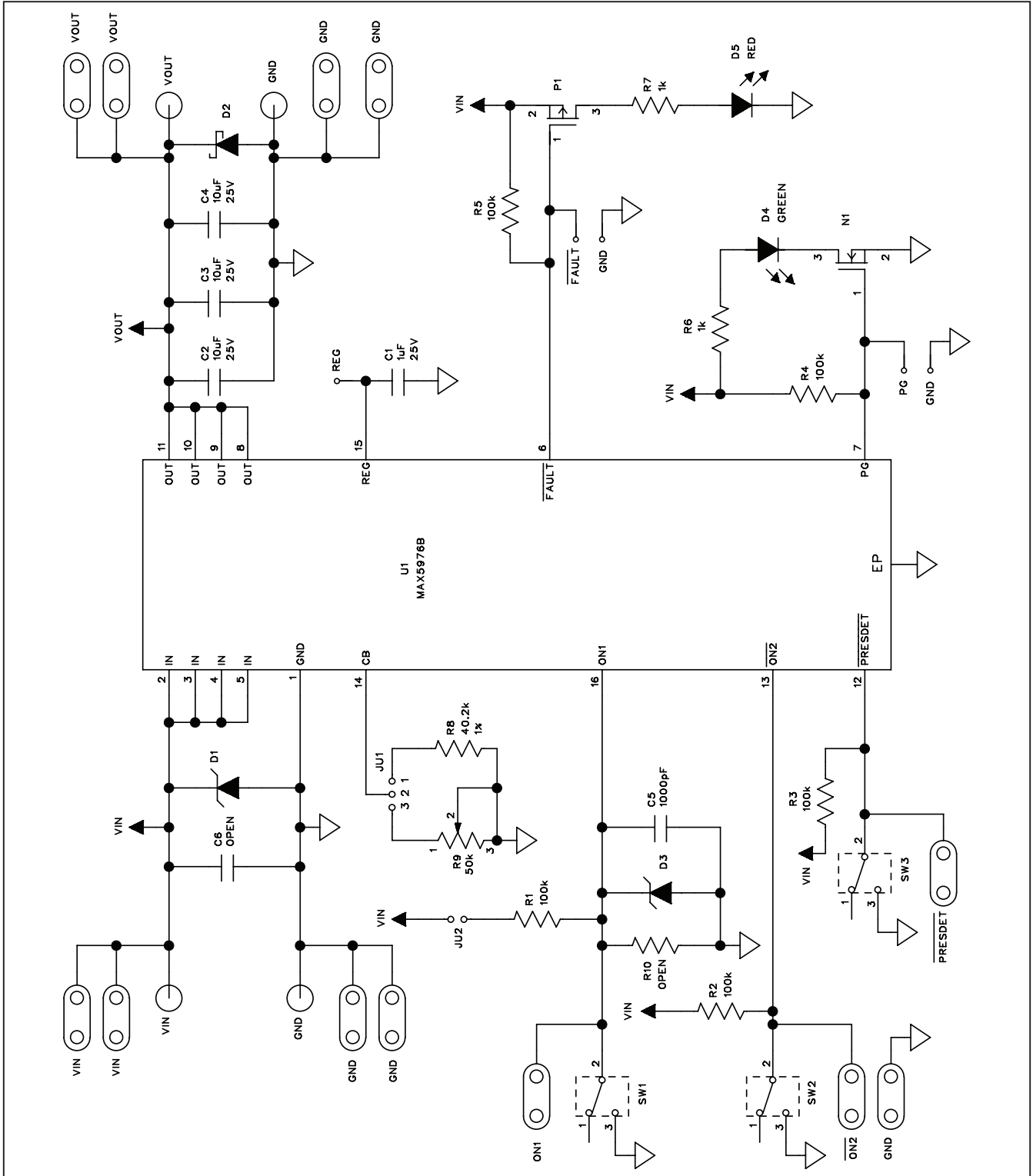

Figure 1. MAX5976B EV Kit Schematic

MAX5976B Evaluation Kit

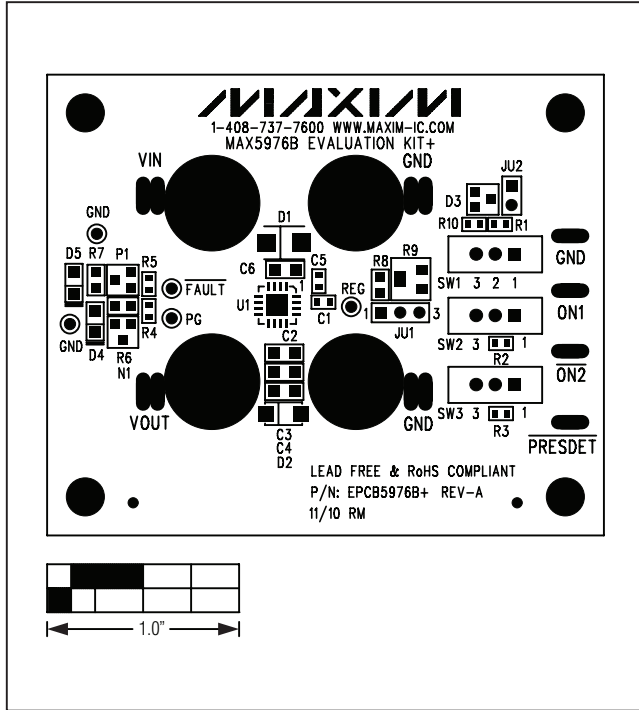

Figure 2. MAX5976B EV Kit Component Placement Guide—Component Side

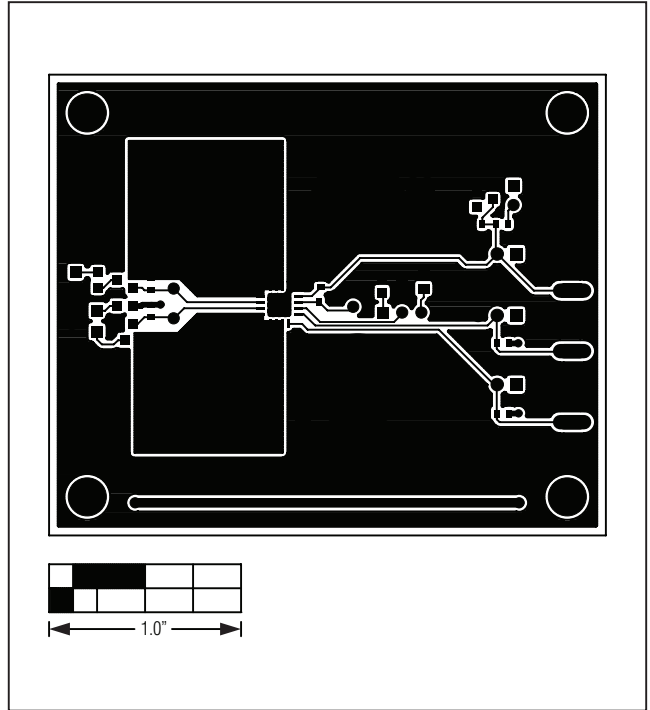

Figure 3. MAX5976B EV Kit PCB Layout—Component Side

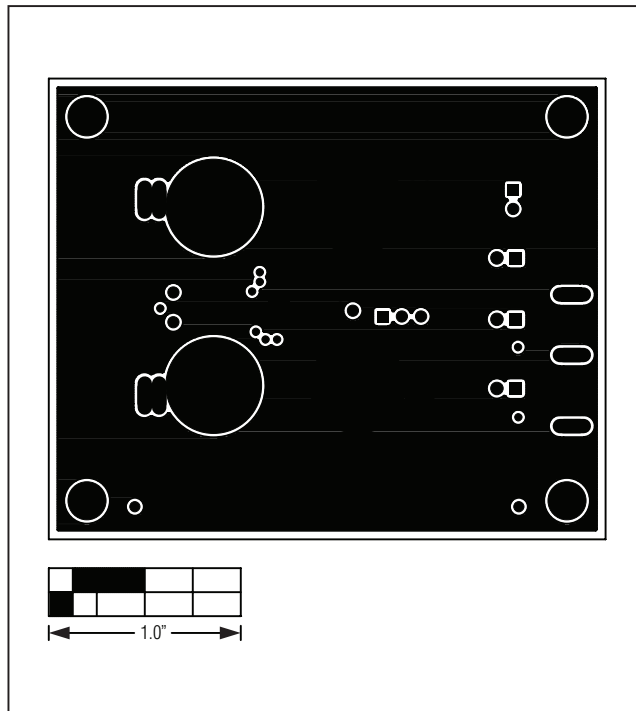
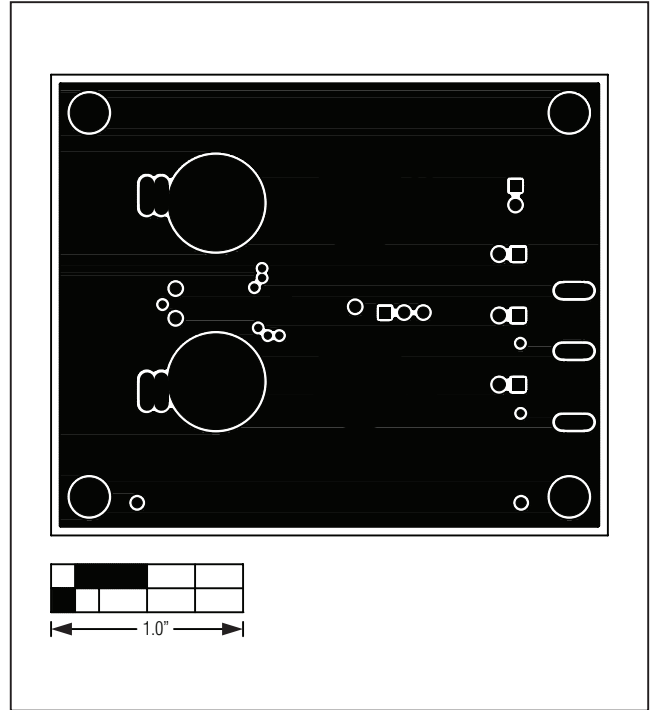
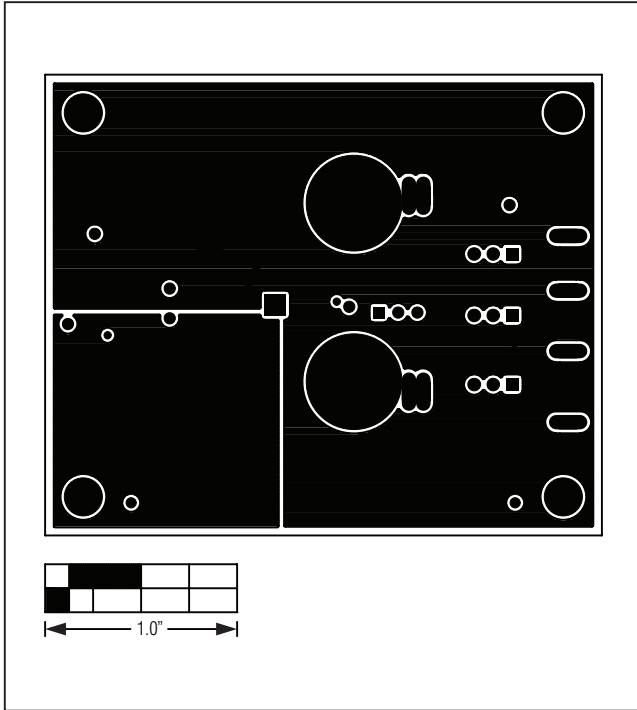

Figure 4. MAX5976B EV Kit PCB Layout—GND Layer 2

MAX5976B Evaluation Kit

Evaluates: MAX5976A/MAX5976B



MAX5976B Evaluation Kit

Evaluates: MAX5976A/MAX5976B

Revision History

REVISION NUMBER	REVISION DATE	DESCRIPTION	PAGES CHANGED
0	1/11	Initial release	—

Maxim cannot assume responsibility for use of any circuitry other than circuitry entirely embodied in a Maxim product. No circuit patent licenses are implied. Maxim reserves the right to change the circuitry and specifications without notice at any time.

8 _____ **Maxim Integrated Products, 120 San Gabriel Drive, Sunnyvale, CA 94086 408-737-7600**

© 2011 Maxim Integrated Products

Maxim is a registered trademark of Maxim Integrated Products, Inc.