

# Atmel ATA6844-DK BLDC Motor Control Kit

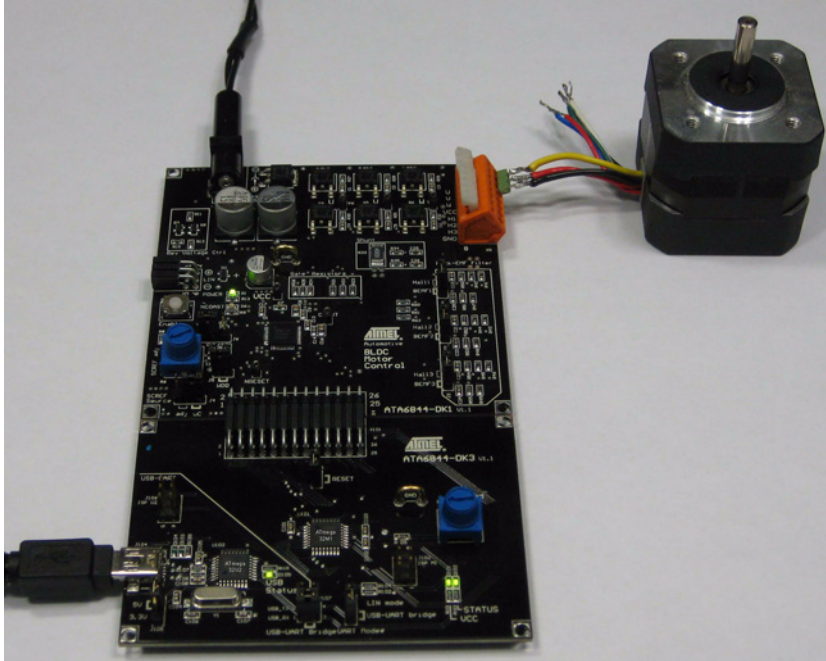

## Atmel ATA6844-DK BLDC Motor Control Kit

## Application Note

### 1. Introduction

The purpose of this document is to explain the Atmel® ATA6844-DK for BLDC motor control application.

The application kit consists of two boards (see [Figure 2-1 on page 2](#)):

- Power Board with the BLDC Gate Driver SBC (System Basis Chip) Atmel ATA6844, 6 external n-channel MOSFETs and back EMF signal conditioning
- Controller Board with the Atmel ATmega32M1 motor control microcontroller and the Atmel ATmega32U2 user interface controller for UART communication.

The main difference between the Atmel ATA6843 and Atmel ATA6844 is their respective temperature range. The maximum junction temperature of 200°C allows “under-the-hood” design solutions with the Atmel ATA6844, while the maximum junction temperature for the Atmel ATA6843 is 150°C. If not otherwise stated, all references to the Atmel ATA6844 apply equally to both devices.

9236A-AUTO-08/11



## 2. BLDC Motor Control Kit with Atmel ATA6843/ATA6844

Figure 2-1. Block Diagram

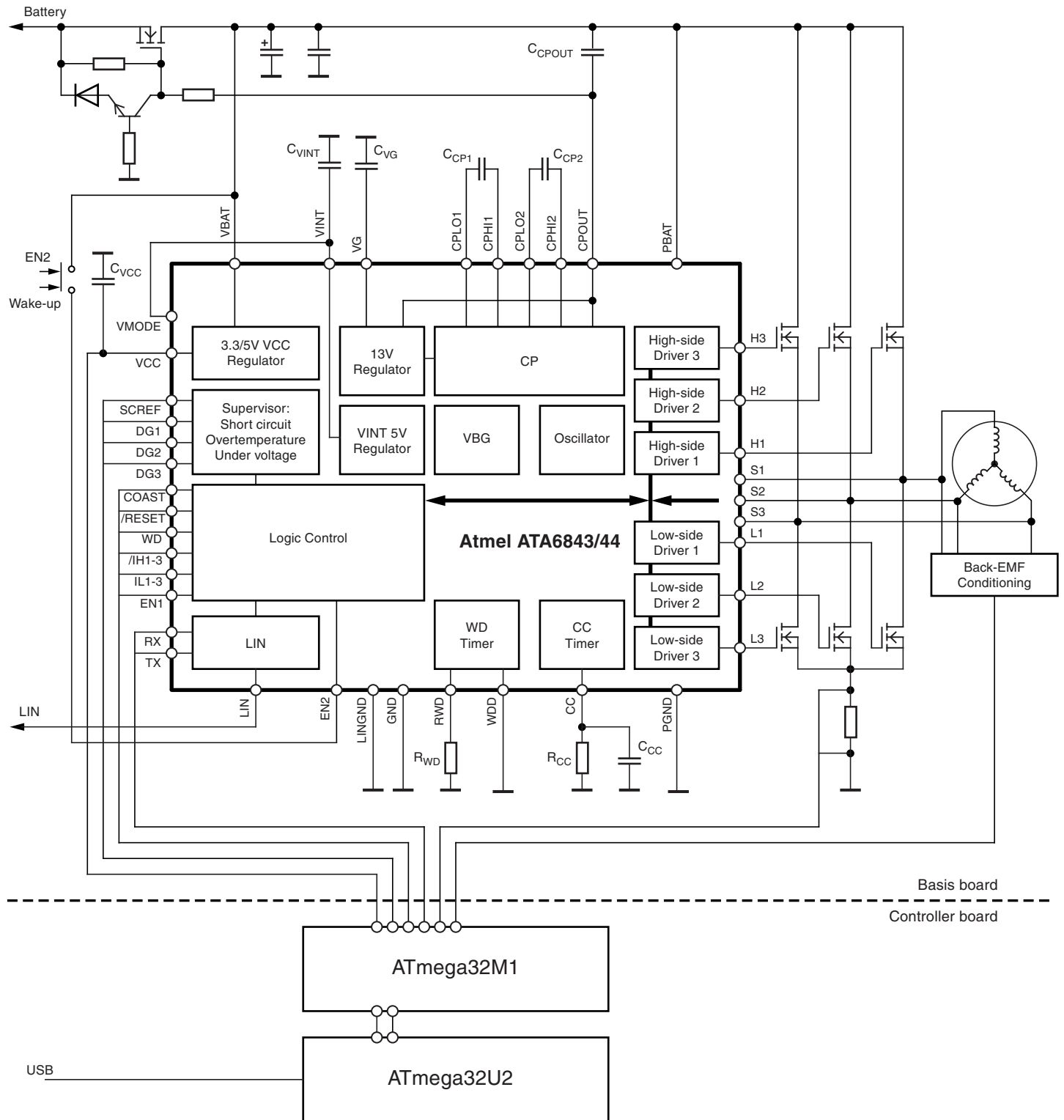

### 3. Theories of BLDC Operation

Brushless DC motors are used in a growing number of applications because of several advantages, including reduced noise, extended service life with no brush wear, reduced noise, a good weight/size-to-power ratio, and their suitability for hazardous operation environment scenarios (with flammable product).

Motors of this kind have slight rotor inertia. Coils are attached to the stator. Commutation is controlled by electronics using position sensor feedback or back electromotive force (back-EMF) measurements.

The BLDC motor stator basically includes three coils which can be replicated to reduce torque ripple. In the same way, rotor basically includes permanent magnets, composed of one to more pairs of poles. This also affects step size (see Figure 3-1). Position can be estimated either by using three Hall sensors, each spread at 120° around the stator or a greater subdivision of higher rotor pole pair counts. Or Position can be estimated by measuring the voltage induced by the back electromotive force, determining the voltage zero crossing.

**Figure 3-1.** Three Coil BLDC Motor, 1 and 2 Pair Poles

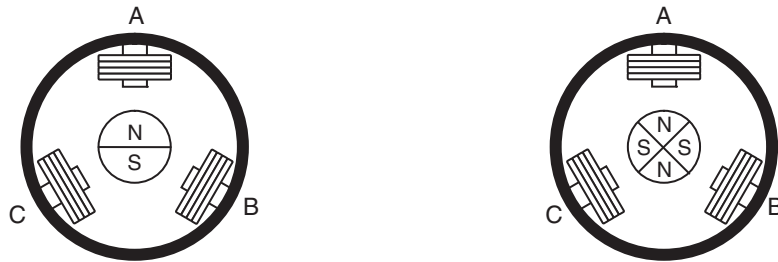

BLDC motor operation can be simplified by considering only three coils and one pair pole. Phase's commutation depends on the position with the Hall sensor value the easiest way to detect it. When motor coils are supplied with energy, a magnetic field is created which sets the rotor in motion. The most elementary commutation driving method is an on-off scheme: a coil is either conducting or not. Only two coils are supplied at the same time, the third is floating. This is referred to as trapezoidal commutation or block commutation.

**Figure 3-2.** Power Stage

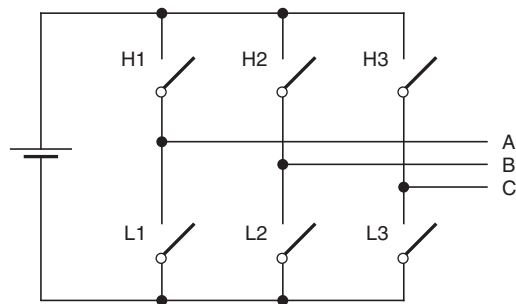

**Figure 3-3.** Commutation Steps for CW Operation

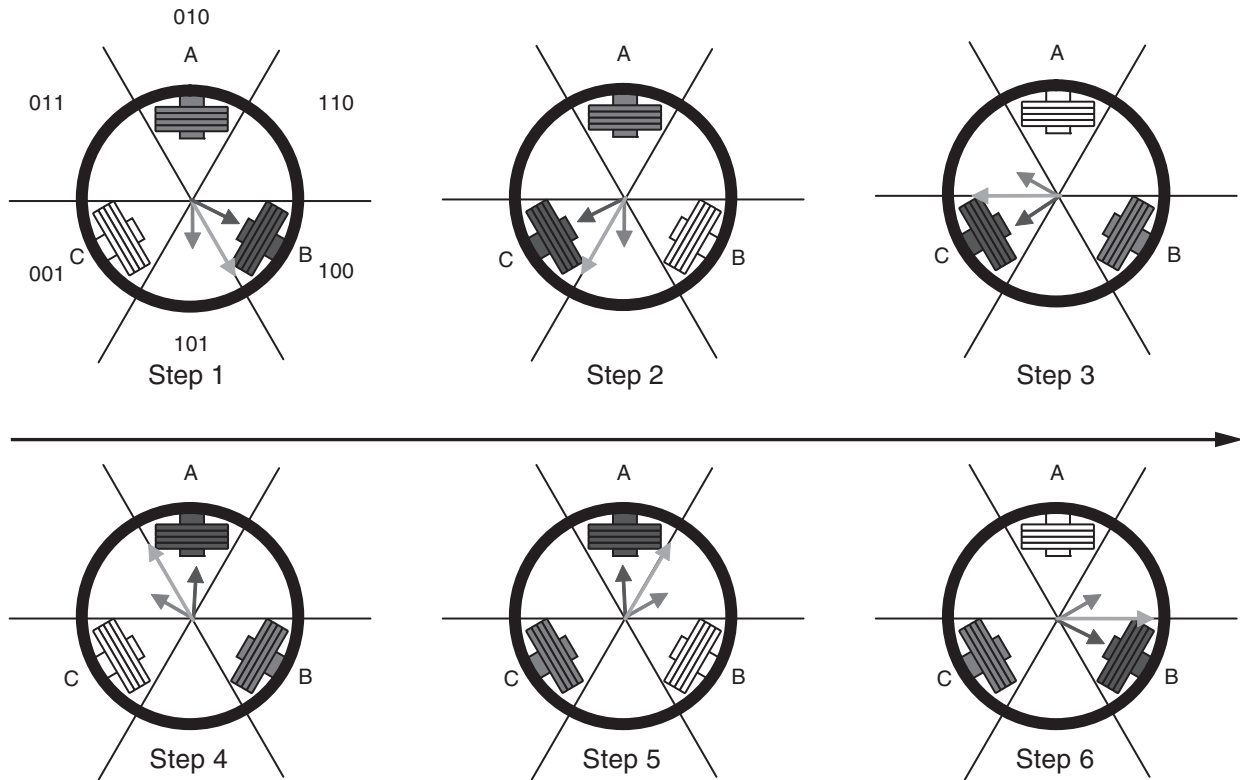

Checking the Hall sensor read-out indicates whether commutation is occurring. For multiple-pole motors, electrical rotation corresponds to mechanical rotation with the pair pole number factor.

**Table 3-1.** Switches Commutation for CW and CCW Rotation

Hall Sensor Value (CBA)	Switch Commutation for CW Rotation		Switch Commutation for CCW Rotation	
	Coils	Switches	Coils	Switches
101	A - B	H1 - L2	B - A	H2 - L1
001	A - C	H1 - L3	C - A	H3 - L1
011	B - C	H2 - L3	C - B	H3 - L2
010	B - A	H2 - L1	A - B	H1 - L2
110	C - A	H3 - L1	A - C	H1 - L3
100	C - B	H3 - L2	B - C	H2 - L3

Commutations are updated at each step to create a rotating magnetic field as shown in [Figure 3-3](#).

This method takes full advantage of the Atmel® ATA6844 in combination with the Atmel ATmega32M1 because commutations can be transmitted at each step while PWM allows independent magnetic field magnitude tuning, to act on motor torque and speed.

## 4. BLDC Motor Position Feedback

The Atmel® ATA6844-DK hardware offers the option not only of Hall sensor feedback but also back EMF feedback. The position feedback source can be selected by the jumpers J1, J2, and J3.

The supplied firmware applies the back EMF feedback method as rotor position feedback. Connecting Hall sensors to the application board is thus unnecessary. X5 pins 4 - 8 can be left open.

Please refer to the Atmel application note “AVR928: Scalar Sensorless Methods to Drive BLDC Motors” for more detailed theoretical information about back EMF.

## 5. The Atmel System Basis Gate Driver ATA6843/ATA6844

The Atmel ATA6844 is designed for automotive applications requiring high-current BLDC motors. The six gate drivers are capable of driving a wide range of n-channel power MOSFETs. To guarantee steady operation down to crank pulse, a double charge pump provides the voltages for driving the external MOSFETs. Overvoltage lockout at 32V opens a wide operating range beyond what is required for jump starts. Direct control of each gate output allows the BLDC to be run in all different commutation shapes.

Diagnostic outputs immediately indicate instances of a short to battery or short to ground, possible at short circuit levels operated externally via the SCREF pin. Battery over-/undervoltage conditions or charge pump failure are also indicated and instantaneously switch off the gate driver outputs. In case of overtemperature, advance warning is indicated to drive into emergency position or reduce power dissipation.

The COAST input pin acts as an emergency stop function. Applying this pin switches the outputs off instantaneously.

Dead time control is a protection feature. The CC (cross conduction) timer can be adjusted to the switch on/off requirements of different external N-channel MOSFETs.

The Atmel ATA6844 includes a voltage regulator, LIN transceiver and window watchdog. The SBC (System Basis Chip) capability of the Atmel ATA6844's enables designs with a reduced component list and limited PCB space.

### 5.1 Cooling Area Design

The Atmel ATA6844 driver IC is housed in a QFN package. The QFN package is highly suitable for a power package because of the exposed die pad. The head slug must be completely soldered to the PCB in order to take advantage of this feature.

To reduce thermal resistance, vias are necessary down to the soldering layer. A suitable ground plane has to be placed on the soldering layer to dissipate thermal energy.

A via diameter of 0.3mm to 0.4mm and a spacing of 1mm to 1.5mm has proven to be the most suitable. Some care should be taken about the planarity of the copper area; special care should be taken to avoid all solder bumps at the thermal vias.

## 5.2 Ground Area Design

The common ground reference point of the BLDC ECU (electronic control unit) is located under the Atmel® ATA6843/ATA6844. The exposed die pad should be connected with the ground layer through vias. The three ground pins GND (11), LINGND (12) and PGND (43) should be connected directly to the die pad.

The N.C. pins (10, 14, 37, 45) are connected to the die pad internally. They should also be connected to the GND plane.

The Atmel ATA6843/ATA6844 has several regulation loops. To achieve good EMC performance, the loops should be as short as possible.

The input capacitor at VBAT 100nF and electrolytic buffer capacitor should be connected between GND input of the ECU and the common ground reference point. The 100nF capacitor should be placed close to the Atmel ATA6844.

The ground of the VINT capacitor should be connected in a star-shaped arrangement directly to the die pad as well as the VMODE pin, depending on the VCC output voltage.

The ground of the digital part should be separated. Common ground connection is at the Atmel ATA6844 because the Atmel ATA6844 contains the logic supply voltage regulator. The ground should be connected in a star-shaped arrangement directly to the die pad of the Atmel ATA6844. This part of the ground is the digital ground circuitry, to which the microcontroller ground belongs.

The two charge pump shuffle capacitors CCP1 and CCP2 should be connected in a short loop, close to the Atmel ATA6844. The VG capacitor should be placed close to the Atmel ATA6844 and connected in a short loop to the ground reference point. The reservoir capacitor at CPOUT can be connected to PBAT to reduce maximum voltage at the capacitor. If connected in this way, voltage strength up to 25V is sufficient.

Due to the high gate charge peak currents, the loops for the high side and low side MOSFET gate drivers should be as short as possible and low inductive.

The gate driver source lines are also part of the switch loops. On the high side, there are the three Sx sensor pins. For the low side, this is the common ground pin, which should be connected very close to three of the source pins of the external low side MOSFETs.

**Figure 5-1.** Ground Area Connections: Reference Point is Atmel® ATA6843/ATA6844 Die Pad

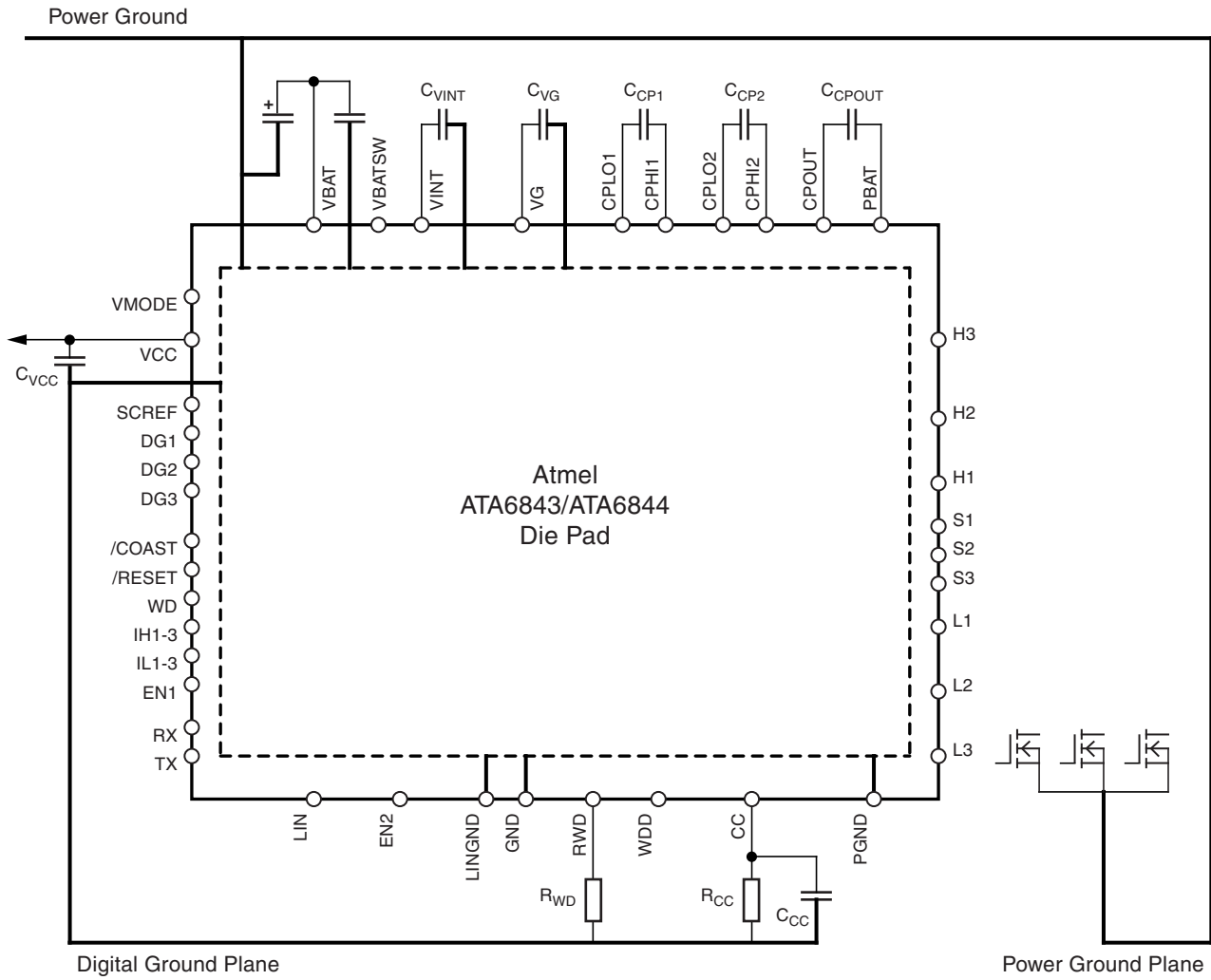

## 6. The Atmel Microcontroller ATmega32M1

The Atmel® ATmega32M1 was developed to provide an integrated solution for advanced motor control applications with CAN and LIN connectivity. Based on high-performance AVR 8-bit RISC architecture, the Atmel ATmega32M1 integrates all of the basic peripherals needed for complex algorithm requirements. It integrates analog blocks such as 10-bit ADC, with differential amplifiers and programmable gain options. Analog comparators with selectable comparison levels, and interrupts on pin change I/Os. Clocked up to 64MHz, the 12-bit versatile synchronous Power Stage Controller generates six complementary programmable high-speed and precision signals to control a motor's three half bridges. A frequency of 64kHz can be achieved, with a resulting duty cycle resolution of about 1/1000. A comparator can serve as overcurrent detection. The reference level can be fixed using the DAC output. Hardware fault detection will automatically and immediately put the motor in a safe position in case a failure is detected.

The microcontrollers provide all necessary resources to control BLDC motors in their system environments.

The Main Features of the Atmel ATmega32M1

- **Data and Non-Volatile Program Memory**
  - 32K Bytes Flash of In-system Programmable Program Memory
  - 1024 Bytes of In-system Programmable EEPROM
  - 2048 Bytes Internal SRAM
- **Peripheral Features**
  - One 12-bit High Speed PSC (Power Stage Controller)
    - Six Non-overlapping Inverted PWM Output Channels with Flexible Dead-time
    - Variable PWM Duty Cycle and Frequency
    - Synchronous Update of all PWM Registers
    - Auto Stop Function for Emergency Event
  - One 8-bit General Purpose Timer/Counter with Separate Prescaler, Compare Mode, and Capture Mode
  - One 16-bit General Purpose Timer/Counter with Separate Prescaler, Compare Mode, and Capture Mode
  - CAN 2.0A/B with 6 Message Objects
  - LIN 2.1 and 1.3 Controller or 8-bit UART
  - One Master/Slave SPI Serial Interface
  - 10-bit ADC with up to 11 Single-ended Channels and 3 Fully Differential ADC Channel Pairs
  - 10-bit DAC for Variable Voltage Reference (Comparators, ADC)
  - Four Analog Comparators with Variable Threshold Detection
  - Interrupt and Wake-up on Pin Change
  - Programmable Watchdog Timer with Separate On-chip Oscillator
  - On-chip Temperature Sensor
- **Special Microcontroller Features**
  - Low Power Idle, Noise Reduction, and Power Down Modes
  - Power On Reset and Programmable Brown Out Detection
  - In-system Programmable via SPI Port
  - Internal Calibrated RC Oscillator (8MHz)
  - On-chip PLL for Fast PWM (64MHz) and CPU (16MHz)

Note: Refer to the Atmel ATmega32M1 data sheet for the complete description of the Atmel ATmega32M1 microcontroller.



## 7. High Ambient Temperature

The Atmel® ATmega32M1 is qualified for use in compliance with the AEC-Q100 Grade 0 standard for automotive grade automotive temperature range. This approval level allows ambient operating temperatures of up to 150°C.

The maximum junction temperature of the Atmel ATA6844 is 200°C. Hence, the available thermal gap for power dissipation in 150°C ambient temperature applications is about 50K. Basically there are three heat sources in the Atmel ATA6844: the VCC voltage regulator, the charge pump and the remaining internal operating circuitry.

To calculate thermal balance please refer to the dedicated application note: “Estimated Junction Temperature Rise Due to Power Dissipation during Operation.”

## 8. The Application Board

### 8.1 Power Board Features

The application basis board provides the following features:

- **Atmel ATA6844 QFN7x7 - 48**
  - 6 Gate Driver Outputs to Operate N-channel MOSFETs
  - VCC Regulator 5V or 3.3V Operation, Window Watchdog, LIN Transceiver up to LIN 2.1 Compliant
- Six External MOSFETs SQD50N04 with Current of up to 50A DC
- Low Drop Reverse Voltage Protection with SQD50N04
- Button SW1 for System Wake-up
- LED Power to Indicate Supply Voltage Present
- LED NCOAST to Indicate Active Coast Function
- Back EMF Sensor Feedback
  - Filter Network to Operate with Enclosed Type FL42BLS01 BLDC Motor
  - Back EMF is Supported by Atmel ATmega32M1 Firmware
- Hall Sensor Feedback
  - Optional, Not Supported by Firmware
  - Designed for Integrated Hall Sensors with 5V Digital Supply
  - The Atmel ATA6843/ATA6844 Can Generate 5V as well as 3.3V Digital Output Voltage.  
Note: Integrated Hall Sensors Usually Work on a 5V Supply Only, BLDC Movement at 3.3V Is Not Possible
- LIN Transceiver
  - Board is Configured as a LIN Slave, without Pull-up and Diode for Master Mode Configuration
  - Access to the Pin via X2 Connector
- SCREF Input
  - Two Selectable Short Circuit Input Threshold Level Inputs
    - Via SCREF Adjustment Potentiometer or
    - Microcontroller Output
- Dimensions: 89mm × 89mm

## 8.2 Controller Board Features

The application controller board has the following features:

- **Atmel ATmega32M1 QFN7x7 - 32**
  - 8-bit AVR Microcontroller
  - 8MHz Internal RC Oscillator, using Internal 64MHz PLL, 16MHz CPU Frequency at 5V VCC Supply Voltage
- **Atmel ATmega32U2 QFN7x7 - 32**
  - 8-bit AVR Microcontroller
  - 8MHz Internal RC Oscillator, 8MHz CPU Frequency at 5V VCC Supply Voltage
- **Connectors**
  - Microcontroller Interface to BLDC Basis Board
  - 6-pin ISP Connector for In-system Programming and On-chip Debugging via debugWIRE using JTAGICEmkII
    - For Atmel ATmega32M1
    - For Atmel ATmega32U2
- **Potentiometers**
  - Target Speed Potentiometer
- **Dimensions: 89mm × 62mm**

The Atmel® ATmega32M1 is required for BLDC operation. The Atmel ATmega32U2 is separated by line and is only required for USB control and can be disconnected by removing jumpers J107.

The function blocks on the application board are clearly arranged, see [Figure 8-1 on page 11](#).

Figure 8-1. Application Board Top View, Function Blocks

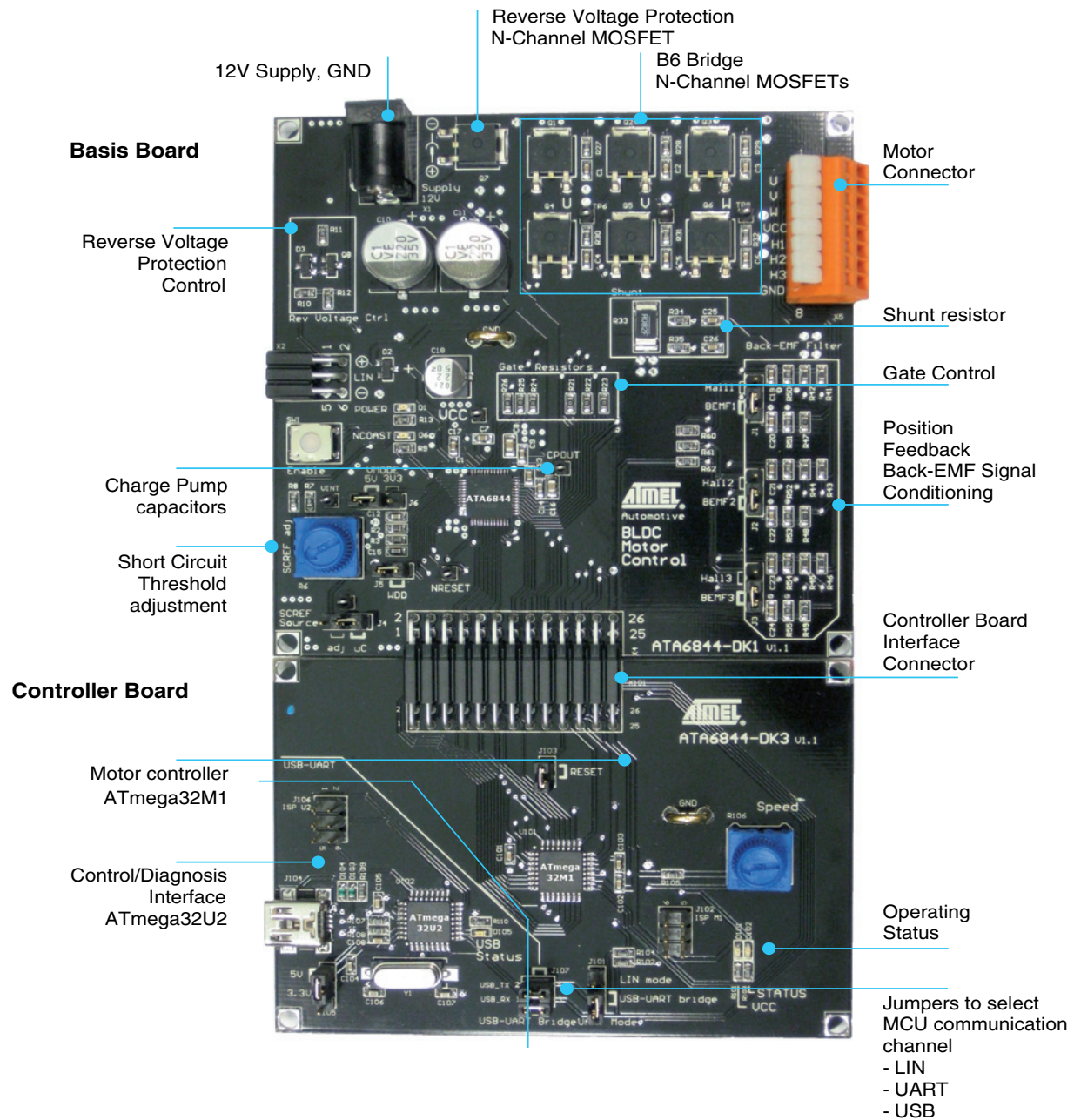

The application kit can be run by supplying 12V to the connector X1 on the application basis board. The Atmel® ATmega32M1 microcontroller is preloaded with software operating the enclosed BLDC motor featuring a back EMF feedback method. The three windings of the BLDC motor need to be connected to the three phase clamps U, V, W, see [Figure 8-2 on page 12](#).

After powering up, the BLDC motor starts operation automatically. The target speed is set up based on the potentiometer speed.

Additional software is available on the enclosed CD for evaluation purposes and is described later in this document.

**Figure 8-2.** Application Board Top View, Connectors

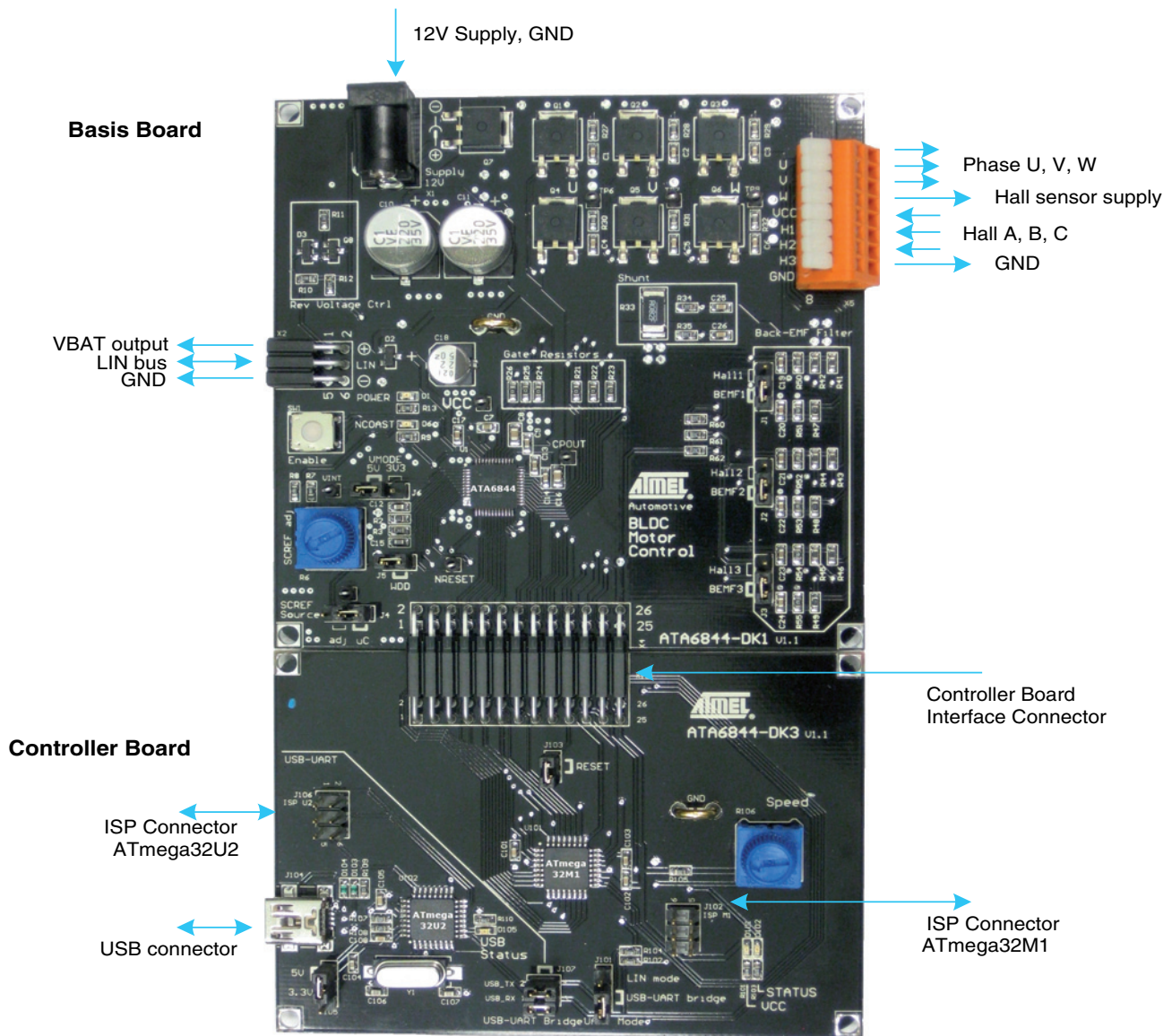

**Table 8-1.** Board Connectors

Connector	Clamp	Function	Direction
X1	1	Power 12V	Power
	2	GND	Power
X2	1, 2	VBAT	Output
	3, 4	LIN	Output
	5, 6	GND	Output
X4	1-26	Microcontroller interface	Power, I/O
X5	1	Phase U	Output
	2	Phase V	Output
	3	Phase W	Output
	4	5V Hall supply (optional)	Power
	5	Hall 1 (optional)	Input
	6	Hall 2 (optional)	Input
	7	Hall 3 (optional)	Input
	8	Hall GND (optional)	Power
X101	1-26	Microcontroller interface	Power, I/O
J102	1-6	ISP connector ATmega32M1	I/O
J106	1-6	ISP connector ATmega32U2	I/O
J104	1-5	USB	I/O

**Figure 8-3.** Application Board Top View, Jumpers, Potentiometers, Buttons, LEDs

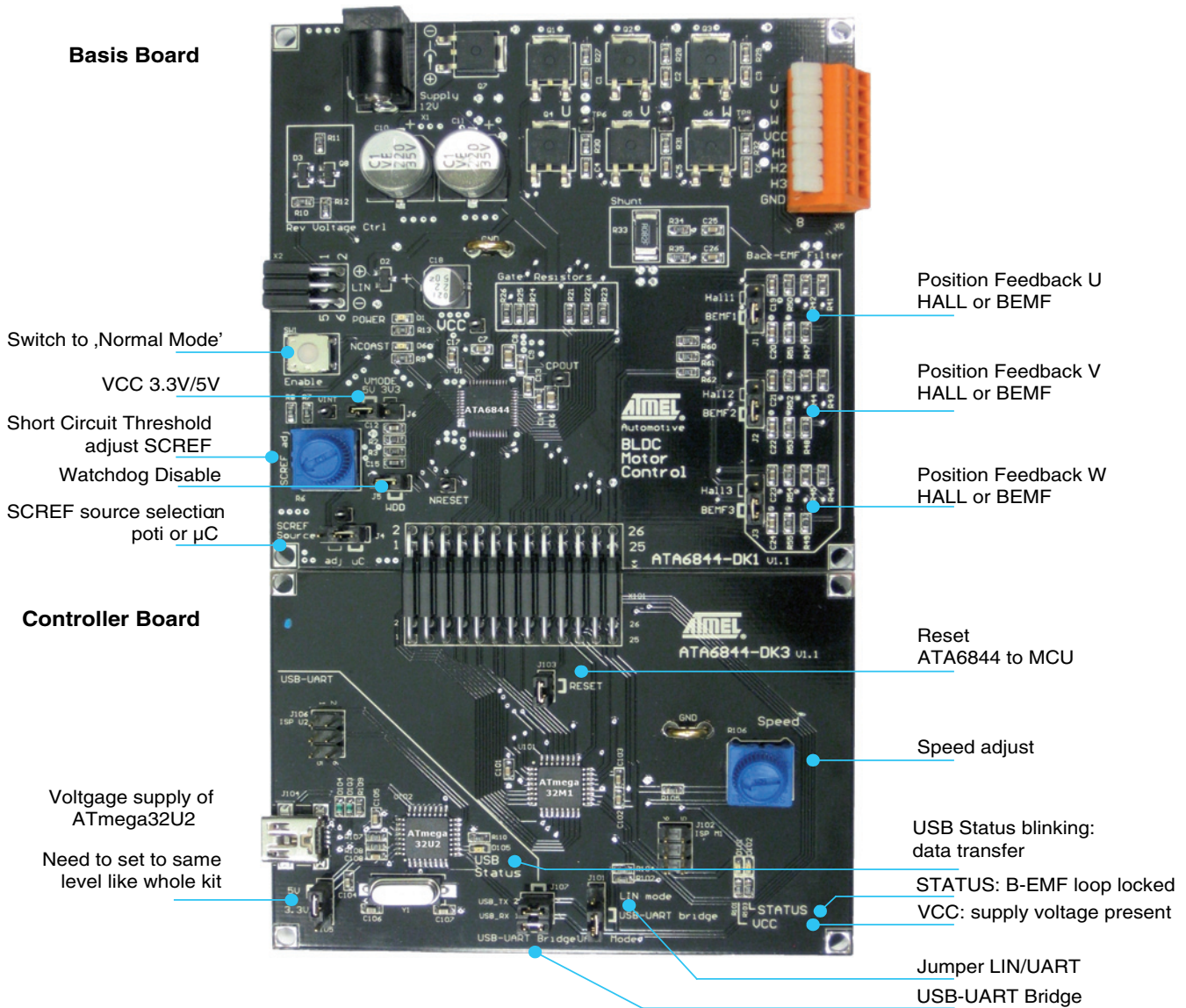

**Table 8-2.** Board Jumpers

Jumper	Function	Clamp	Comment
J1, J2, J3	Feedback input x	1 – 2	Hall x input (default)
		2 – 3	Back EMFx input
J4	SCREF threshold source	1 – 2	Microcontroller (default)
		2 – 3	Potentiometer R6
J5	Watchdog disable	On	Watchdog disable (default)
		Off	Watchdog enable
J6	VMODE select VCC voltage	1 – 2	3.3V mode
		2 – 3	5V mode (default)

**Table 8-3.** Board Switches

Switch	Function
SW1	High voltage wake-up switch – EN pin

**Table 8-4.** Board Potentiometers

Potentiometer	Function	Comment
R6	SCREF	Input source for SCREF threshold, depending on J4 jumper setting
R106	Speed	ADC input for ATmega32M1, in the enclosed firmware assigned as target speed input

**Table 8-5.** LEDs

LED	Function	Comment
D1	POWER	ON: Power board is supplied
D6	COAST	ON: Coast active Coast can only be set by the ATmega32M1 microcontroller
D101	VCC	ON: VCC valid, Atmel ATA6844 in normal mode OFF: No VCC present, Atmel ATA6844 in standby mode
D102	STATUS	ON: BLDC back EMF feedback loop locked
D105	USB status	Toggle: character sent The LED D105 changes status on each transmit in both directions, from and to PC

## 8.3 Power Board Startup

For startup, several test pins are prepared to monitor.

- As soon as the kit is powered, 5V is present at the VINT test pin.
- If the Atmel® ATA6843/ATA6844 is in normal mode, VCC is present. Depending on the VMODE jumper setting, the VCC pin voltage level is 3.3V or 5V.
- If VCC is in a valid range and the watchdog receives correct triggers within the watchdog window, the NRESET signal remains stable at the VCC level.
- Finally, correct function can be monitored at the charge pump output pin. The voltage there is 15V above supply voltage. The charge pump frequency is approximately 400kHz.

## 8.4 Diagnosis via UART

In an automotive environment, there are several ways to communicate with the motor control unit. The established bus protocols LIN and CAN are supported by the Atmel® ATmega32M1 microcontroller.

### 8.4.1 LIN Communication

The Atmel ATA6844 system basis chip gate driver has a LIN transceiver on chip. A brushless BLDC application node can be achieved by combining the Atmel ATmega32M1 LIN protocol features. For LIN operation, it is necessary to set the UART mode to LIN mode, jumper J101, and remove both J107 jumpers, for more information see [Figure 8-4](#).

Note: The LIN software is not supported by the preloaded firmware.

**Figure 8-4.** Jumper Settings for LIN UART

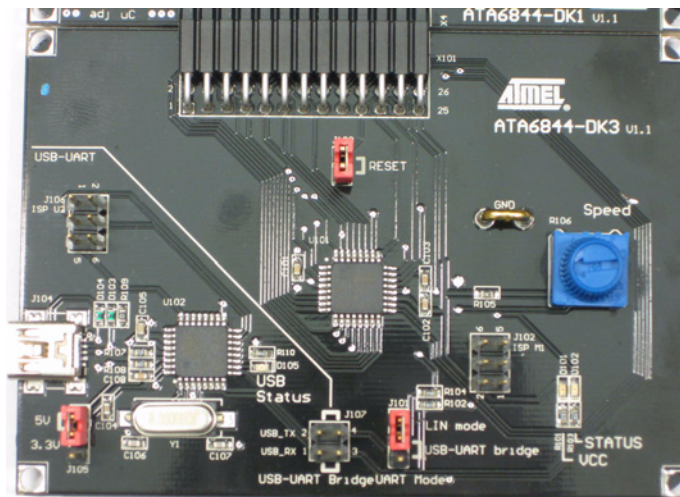



## 8.4.2 UART Communication

The UART communication port is for debugging and monitoring purpose. A list of commands is implemented, see [Table 9-1 on page 21](#).

For direct access to the pins, set the jumper and connect according to [Figure 8-5](#).

**Figure 8-5.** Jumper Settings for Direct UART Access

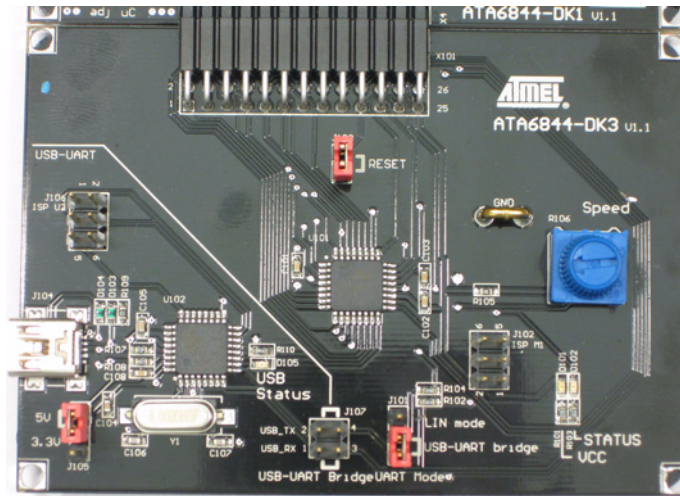

A UART to USB bridge is on the controller board to access via hyper terminal. The jumpers need to be set according to [Figure 8-6](#). The USB drivers need to be installed according to 'Setup USB connection'.

**Figure 8-6.** Jumper Settings for UART Access by USB Connection and Hyper Terminal

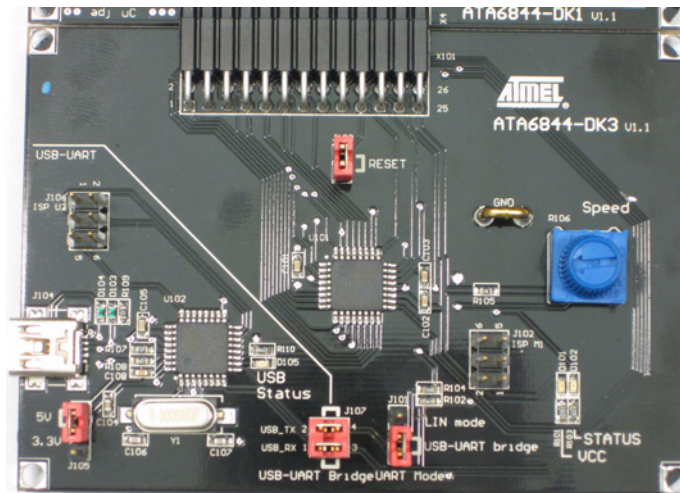

## 9. Software Description

There are two software packages available from the Web site or on the supplied CD:

- Demonstration software
- Evaluation Software

The Board is preloaded with the demo software. Further investigations can be done with the evaluation software. Both software packages are working with back EMF feedback. Operation monitoring by USB connection is provided for both software packages.

The board can be connected to the automotive environment via a LIN bus or by LIN clamp. LIN protocol is not supported by the supplied software.

### 9.1 Setup of the USB Connection

When connecting the Atmel® ATA6844 controller board to a PC USB interface, the board is detected as a USB device. The dedicated driver has to be installed on the PC if the Atmel microcontroller ATmega32U2 type is being used for the first time. The following steps guide the designer through the installation process. The process is described for Windows XP and is similar for other Microsoft operating systems.

If the driver is not present, the user is prompted to install the driver. For more information see [Figure 9-1](#). Be sure not to allow a connection to Windows Update. It is mandatory to install the enclosed driver “at90usbxxx\_cdc.inf” to operate using the Atmel ATmega32U2 USB device. Please select “No, not this time.”

**Figure 9-1.** USB Found New Hardware



Next, choose the driver location “Install from a list or specific location,” see [Figure 9-2](#).

**Figure 9-2.** USB Specific Software



According to [Figure 9-3](#), select the installation path. The “at90usbxxx\_cdc.inf” file is located on the path “\software\ATA6844DK\_mega32u2” on the enclosed driver CD.

**Figure 9-3.** USB Driver Location

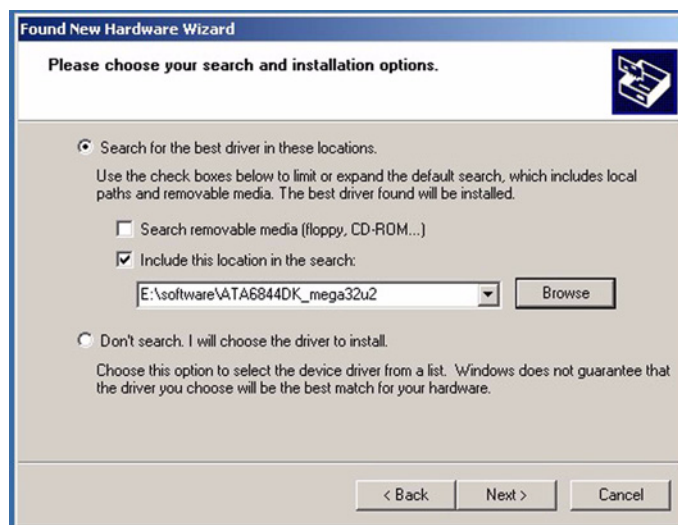

Please continue with the following note, see [Figure 9-4](#).

**Figure 9-4.** USB Windows Logo Testing

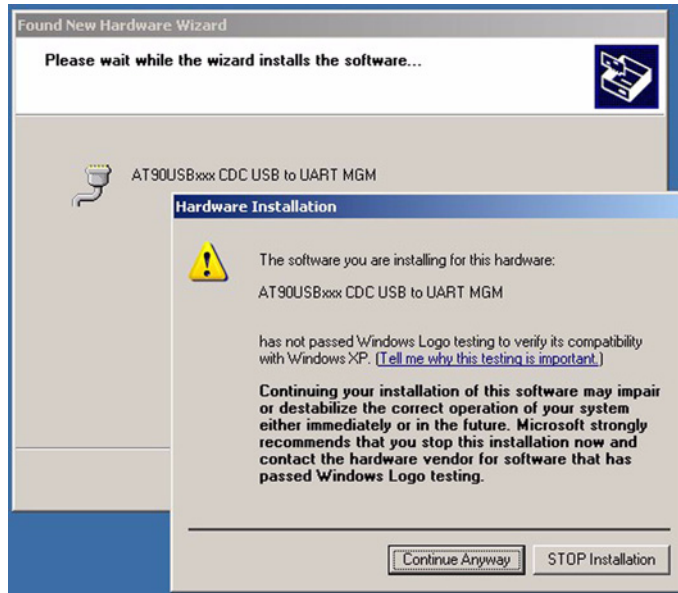

The installation is finished after completing the previous steps. By connecting the USB device, the PC is able to communicate with the Atmel<sup>®</sup> ATA6844 DK design kit by a virtual COM port. The assigned COM port number can be seen in the Windows device manager, [Figure 9-5](#). The device name is “AT90USBxxx CDC USB to UART MGM”.

**Figure 9-5.** Windows Device Manager - COM Port Number

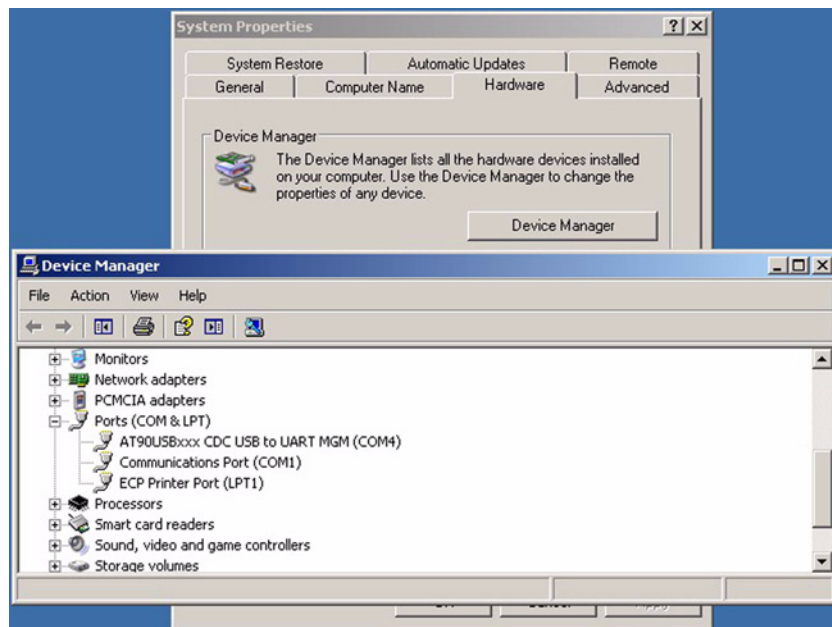

Every terminal software such as “Hyperterminal” within the Microsoft Windows operating system is capable of working as a user interface. The properties of the COM port are 9600Baud, 8 data bits, non-parity check, 1 stop bit and non-flow control.

## 9.2 Demonstration Software

The BLDC motor starts automatically after powering up the application kit. The final stage of the ramp-up process is locking in the back EMF feedback loop. The motor speed is controlled by a speed regulation loop. The target speed can be adjusted by the speed potentiometer.

The speed can be monitored by a hyper terminal. With any key pressed, the display of the current speed can be toggled on or off.

## 9.3 Evaluation Software

The default mode of the evaluation software acts like the demonstration software, ramp-up is done automatically.

Access by hyperterminal allows advanced control of the regulation loop. [Table 9-1](#) shows the entire command list. The automatic startup control ([Figure 9-6 on page 22](#)) can be interrupted by switching to debug mode (pressing key <d>). Switching between the various startup functions must be done manually according to the command [Table 9-1](#). The <+>, <->, <\*> and <\_> keys allow the timing parameters to be adjusted during startup. The parameters are calculated automatically only in the final mode MC\_LOCKED.

**Table 9-1.** Evaluation Software: UART Command Control

Key <parameter>	Function
Space	Read current RPM
r	RUN (clockwise)
R	RUN (counterclockwise)
s	STOP motor
S <xxxx>	Set speed to xxxx rpm
v <x>	Set SCREV voltage
d	DEBUG on
D	DEBUG off
?	Read status of DG pins
l	Force back EMF state MC_LOCKED
p	Force back EMF state MC_PRELOCKED1
i	Enable AC interrupts
l	Disable AC interrupts
+	Increment zero crossing delay
-	Decrement zero crossing delay
*	Increment PWM duty cycle
_	Decrement PWM duty cycle
c	Emergency shutdown of motor: Activate Coast function
C	Emergency shutdown of motor: Deactivate Coast function

## 9.4 Startup Software Algorithm

Basically, the software is separated into two parts: the driver part and the sensor part. The driver part contains PWM generation and commutation control. The sensor part contains analog comparators for back EMF feedback and ADC measurements for current feedback. Differentiation between the parts is more strictly emphasized during the startup sequence.

The startup sequence is controlled by a state machine, see [Figure 9-6](#).

**Figure 9-6.** Flow Chart

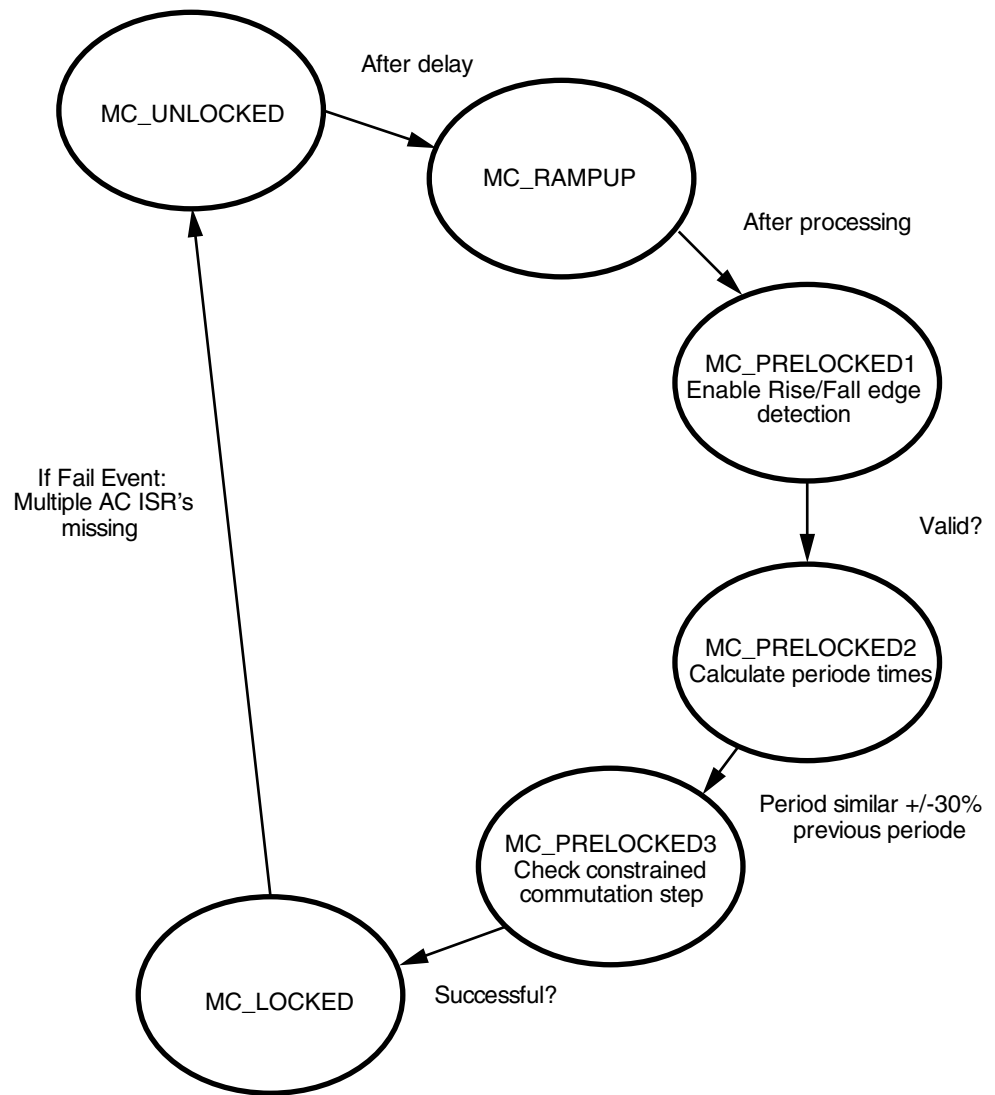

## 9.4.1 MC\_UNLOCKED

- No control is possible because there is no back EMF feedback for commutation control. No PI controller is running for PWM duty-cycle control.
- PWM duty-cycle and the commutation delay time are predefined software parameters.
- The motor starts with a fixed PWM signal and a constrained commutation cycle.
- The ADC runs in parallel and measures at four different points between the commutation steps.
- >debug mode< - the state machine stays in this mode as long as the user switches manually into another mode (command control via UART interface).
- >normal mode< - the state machine switches automatically into the next MC\_PRELOCKED mode after a pre-programmed time.

## 9.4.2 MC\_RAMPUP (Not Yet Implemented/Activated)

- This state is intended to implement code for BLDC motor acceleration until sufficient back EMF signal can be detected. In the implemented software, only a single set of PWM and duty cycle values is active. The single set is sufficient to start the enclosed motor.
- The MC\_RAMPUP mode improves the startup behavior in case of PWM duty-cycle and the corresponding commutation time for a reliable back EMF feedback is not known. This mode provides more stable startup especially for parameters of unknown BLDC motors or varying loads.

## 9.4.3 MC\_PRELOCKED1

- The interrupt service routines (ISR) for falling and rising edges of the internal analog comparators (AC) and the back EMF feedback are enabled. The commutation is not yet controlled based on these measured parameters.
- The state machine switches automatically into the next MC\_PRELOCKED mode

Note: Enabled AC ISRs in UNLOCKED mode can disturb the startup phase, because it is very important for the PI controller to get certain back EMF data from the AC data pipeline. Acquiring useful back EMF data is only possible with a motor running so that sufficient back EMF voltage is generated.

## 9.4.4 MC\_PRELOCKED2

- The AC falling and rising edges are time stamped and stored in a buffer (AC data pipeline). The averages of the time stamps are calculated.
- The state machine switches automatically into the next MC\_PRELOCKED mode as soon as the calculated average of one electrical rotation is identical (about  $\pm 30\%$ ) to six times the constrained commutation time.

Note: The comparison is an indicator for reliability of the AC data pipeline. The faster the rotation, the better matches result for this comparison.

#### 9.4.5 MC\_PRELOCKED3:

- The MC\_PRELOCKED3 mode ensures the transfer from the uncontrolled MC\_PRELOCKED2 mode to the fully controlled MC\_LOCKED mode.
- In this mode, the state machine waits until the next constrained commutation occurs. Afterwards, switching into the MC\_LOCKED mode is initiated.

#### 9.4.6 MC\_LOCKED:

- The PWM duty-cycle is automatically generated by the PI controller.
- The delay commutation times are calculated based on the AC data pipeline.
- An emergency commutation step is forced if an AC ISR is missing within a specific time frame.
- If multiple AC ISRs are missing in succession, the state machine automatically reverts to the MC\_UNLOCKED mode.

The software is implemented in C language and the source code can be compiled with the Compilers from IAR Systems as well as from GCC for AVR.



## 10. Application Board Documentation

### 10.1 BLDC Application Power Board Atmel ATA6844-DK1

Figure 10-1. Atmel® ATA6844-DK1 Power Board - Schematic

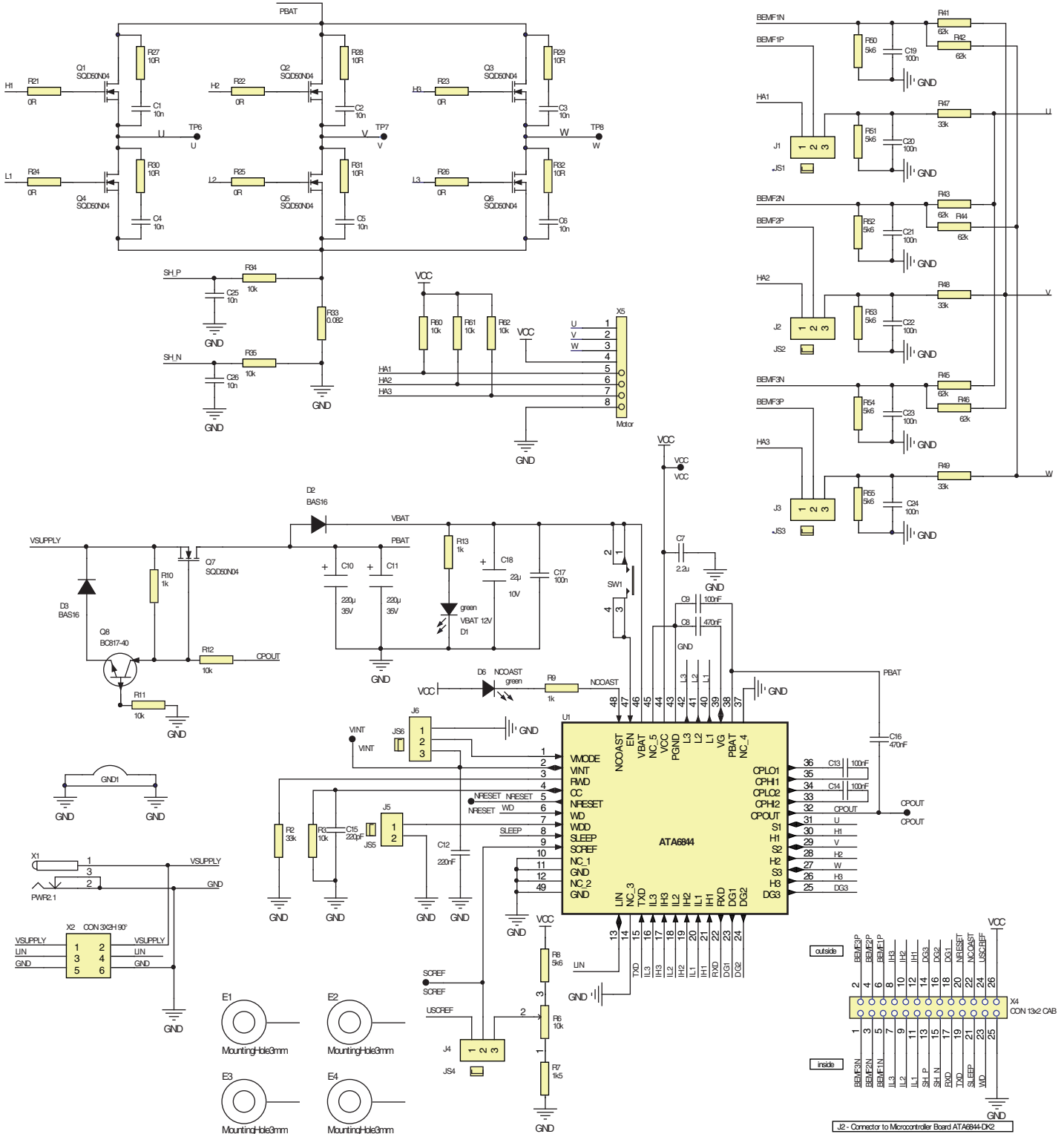

J2 - Connector to Microcontroller Board ATA6844-DK2

Figure 10-2. Atmel® ATA6844-DK1 Power Board - Component Placement

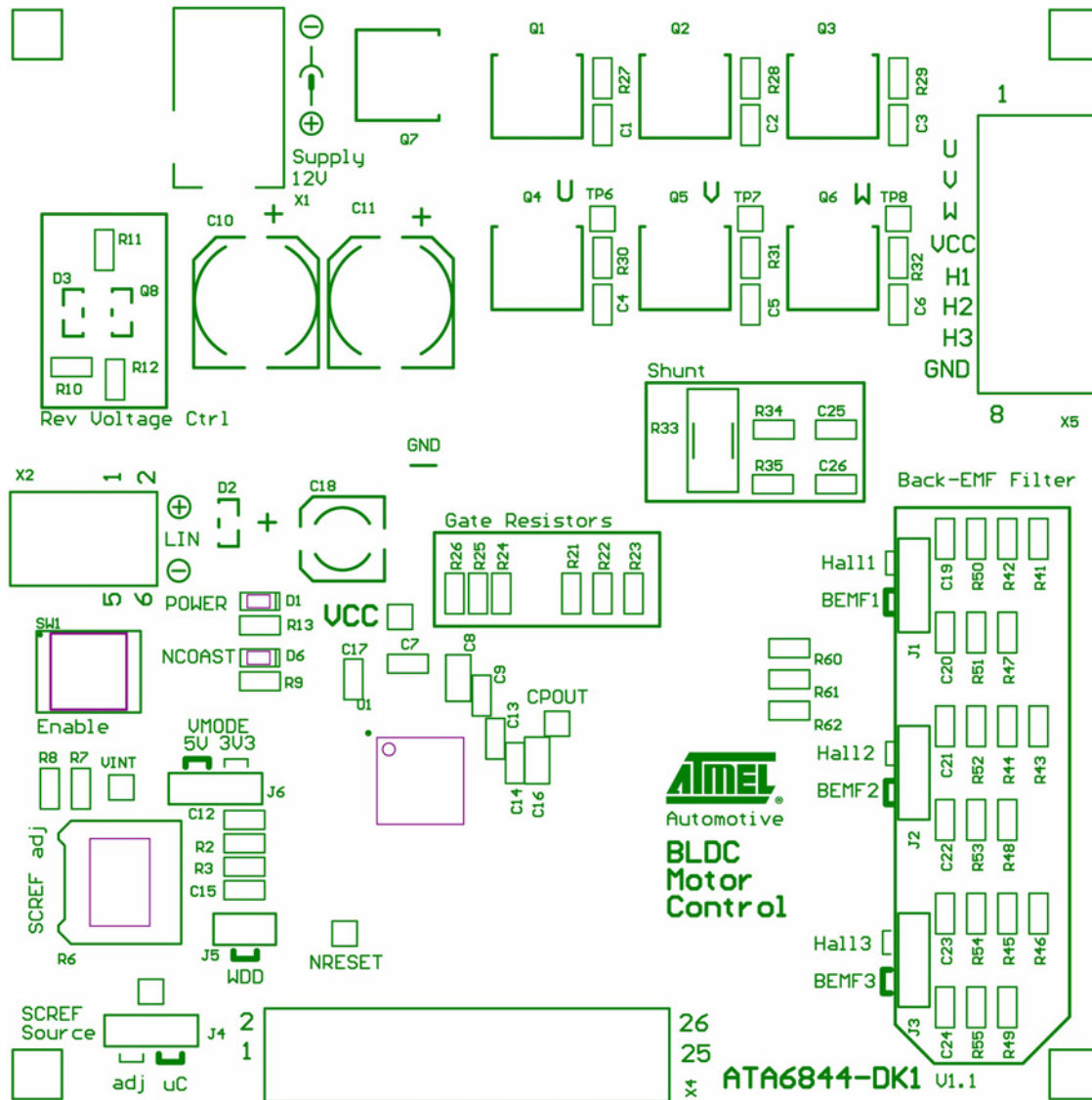

**Figure 10-3.** Atmel® ATA6844-DK1 Power Board - Top Layer - Top View

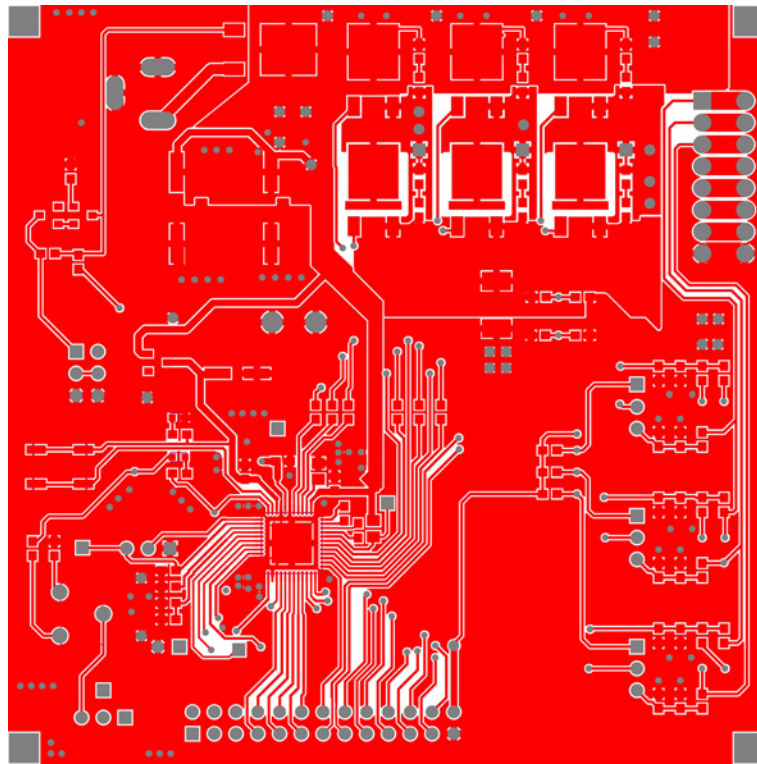

**Figure 10-4.** Atmel ATA6844-DK1 Power Board - Bottom Layer - Top View as PCB is Transparent

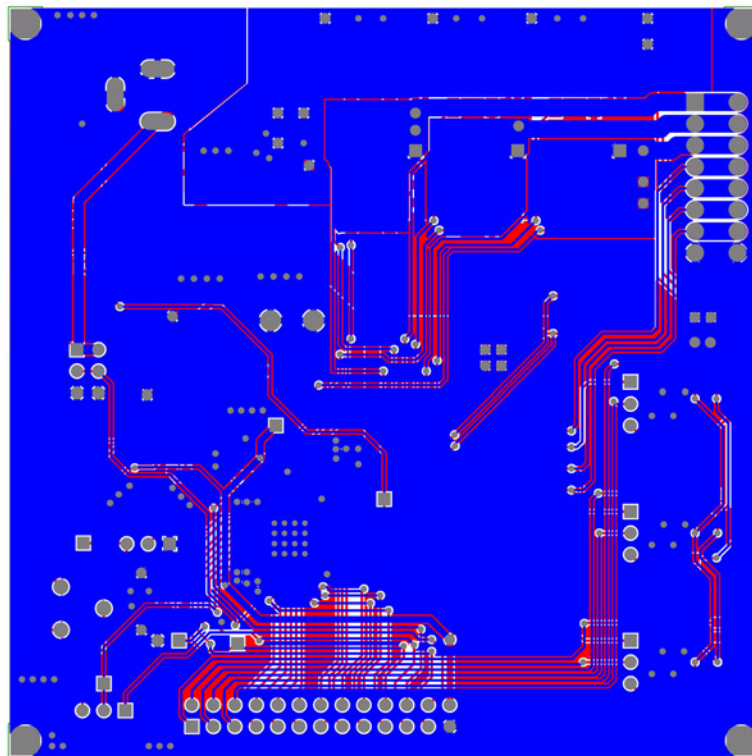

## 10.2 BLDC Application Controller Board Atmel ATA6844-DK3

Figure 10-5. Atmel® ATA6844-DK3 Controller Board - Schematic

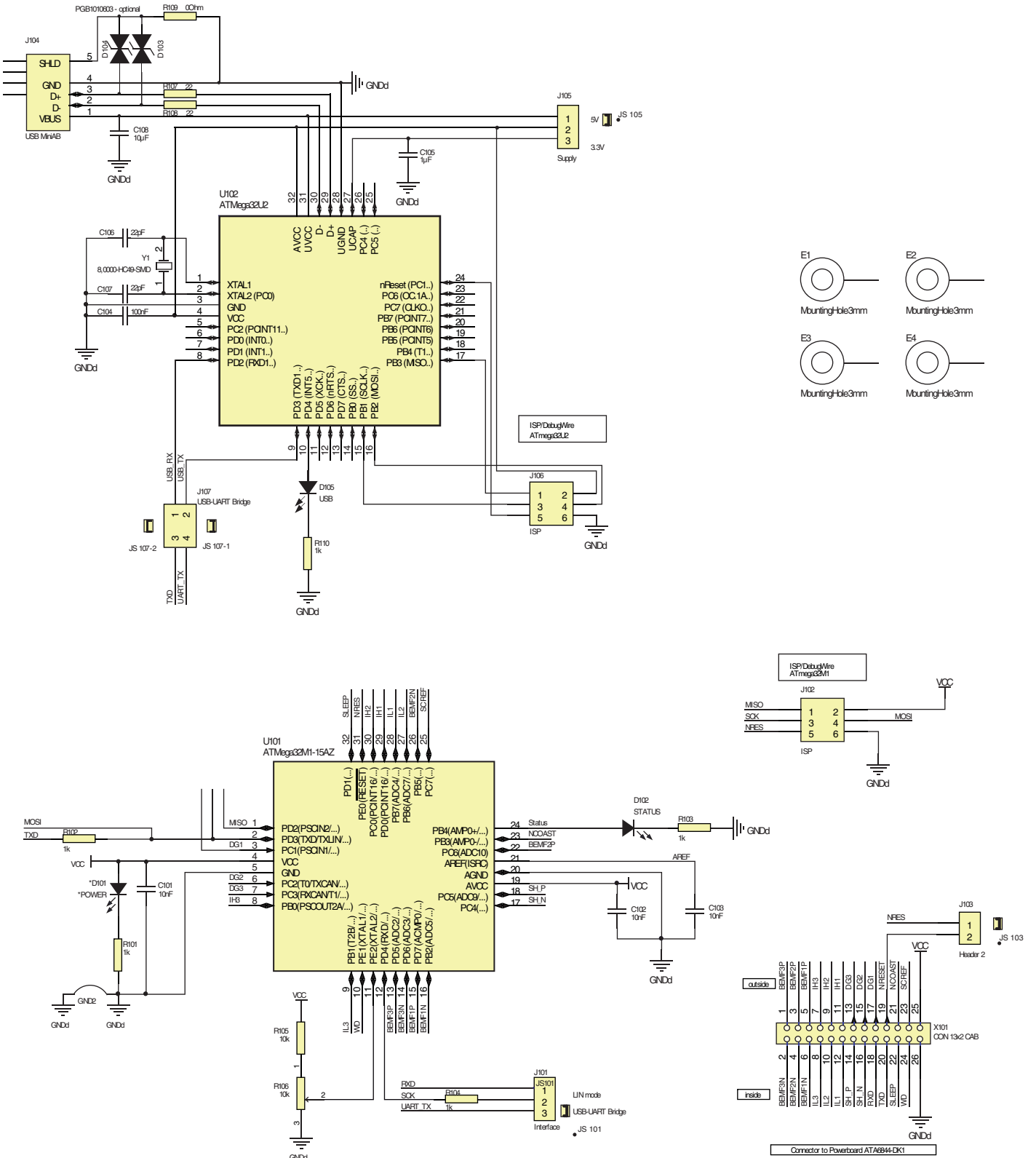
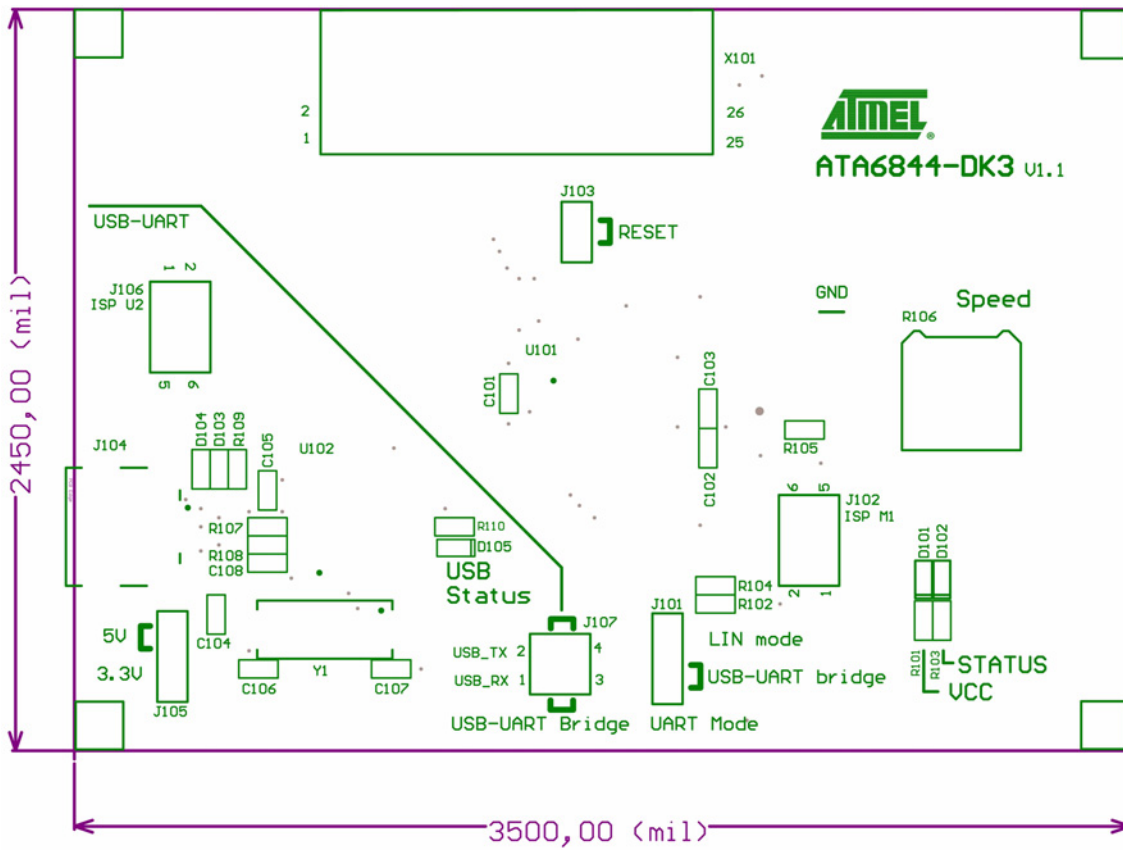
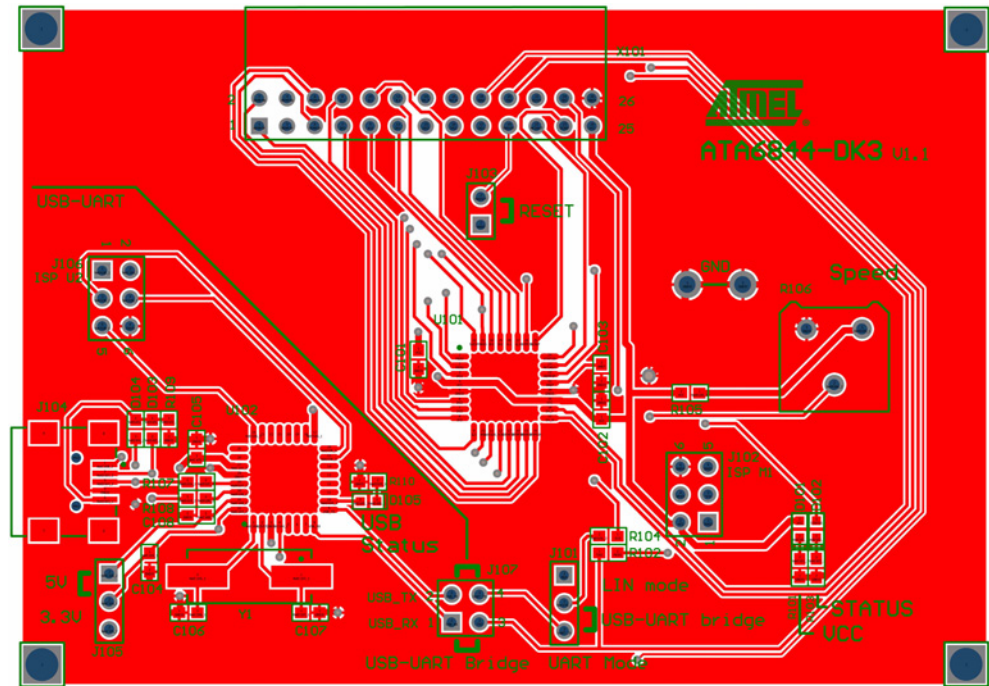

Figure 10-6. Atmel® ATA6844-DK3 Controller Board - Component Placement



**Figure 10-7.** Atmel® ATA6844-DK3 Controller Board - Top Layer - Top View



**Figure 10-8.** Atmel ATA6844-DK3 Controller Board - Bottom Layer - Top View as PCB is Transparent

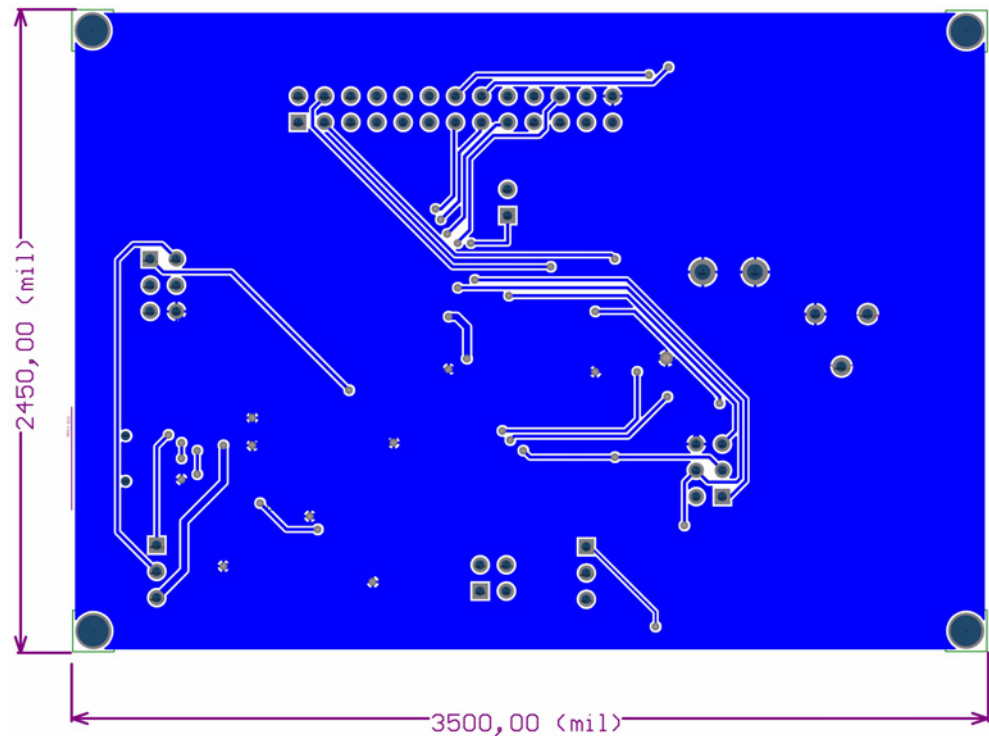



**Atmel Corporation**  
2325 Orchard Parkway  
San Jose, CA 95131  
USA  
**Tel:** (+1)(408) 441-0311  
**Fax:** (+1)(408) 487-2600

**Atmel Asia Limited**  
Unit 01-5 & 16, 19/F  
BEA Tower, Millennium City 5  
418 Kwun Tong Road  
Kwun Tong, Kowloon  
HONG KONG  
**Tel:** (+852) 2245-6100  
**Fax:** (+852) 2722-1369

**Atmel Munich GmbH**  
Business Campus  
Parking 4  
D-85748 Garching b. Munich  
GERMANY  
**Tel:** (+49) 89-31970-0  
**Fax:** (+49) 89-3194621

**Atmel Japan**  
9F, Tonetsu Shinkawa Bldg.  
1-24-8 Shinkawa  
Chuo-ku, Tokyo 104-0033  
JAPAN  
**Tel:** (+81) (3) 3523-3551  
**Fax:** (+81) (3) 3523-7581

© 2011 Atmel Corporation. All rights reserved. / Rev.: 9236A-AUTO-08/11

Atmel®, Atmel logo and combinations thereof, and others are registered trademarks or trademarks of Atmel Corporation or its subsidiaries. Other terms and product names may be trademarks of others.

Disclaimer: The information in this document is provided in connection with Atmel products. No license, express or implied, by estoppel or otherwise, to any intellectual property right is granted by this document or in connection with the sale of Atmel products. EXCEPT AS SET FORTH IN THE ATMEL TERMS AND CONDITIONS OF SALES LOCATED ON THE ATMEL WEBSITE, ATMEL ASSUMES NO LIABILITY WHATSOEVER AND DISCLAIMS ANY EXPRESS, IMPLIED OR STATUTORY WARRANTY RELATING TO ITS PRODUCTS INCLUDING, BUT NOT LIMITED TO, THE IMPLIED WARRANTY OF MERCHANTABILITY, FITNESS FOR A PARTICULAR PURPOSE, OR NON-INFRINGEMENT. IN NO EVENT SHALL ATMEL BE LIABLE FOR ANY DIRECT, INDIRECT, CONSEQUENTIAL, PUNITIVE, SPECIAL OR INCIDENTAL DAMAGES (INCLUDING, WITHOUT LIMITATION, DAMAGES FOR LOSS AND PROFITS, BUSINESS INTERRUPTION, OR LOSS OF INFORMATION) ARISING OUT OF THE USE OR INABILITY TO USE THIS DOCUMENT, EVEN IF ATMEL HAS BEEN ADVISED OF THE POSSIBILITY OF SUCH DAMAGES. Atmel makes no representations or warranties with respect to the accuracy or completeness of the contents of this document and reserves the right to make changes to specifications and products descriptions at any time without notice. Atmel does not make any commitment to update the information contained herein. Unless specifically provided otherwise, Atmel products are not suitable for, and shall not be used in, automotive applications. Atmel products are not intended, authorized, or warranted for use as components in applications intended to support or sustain life.