

DATA SHEET

J108; J109; J110 N-channel silicon junction FETs

Product specification
Supersedes data of April 1995
File under Discrete Semiconductors, SC07

1996 Jul 30

N-channel silicon junction FETs

J108; J109; J110

FEATURES

- High speed switching
- Interchangeability of drain and source connections
- Low $R_{DS(on)}$ at zero gate voltage ($<8 \Omega$ for J108).

APPLICATIONS

- Analog switches
- Choppers and commutators.

DESCRIPTION

N-channel symmetrical silicon junction field-effect transistors in a TO-92 package.

CAUTION

The device is supplied in an antistatic package. The gate-source input must be protected against static discharge during transport or handling.

PINNING - TO-92

PIN	SYMBOL	DESCRIPTION
1	g	gate
2	s	source
3	d	drain

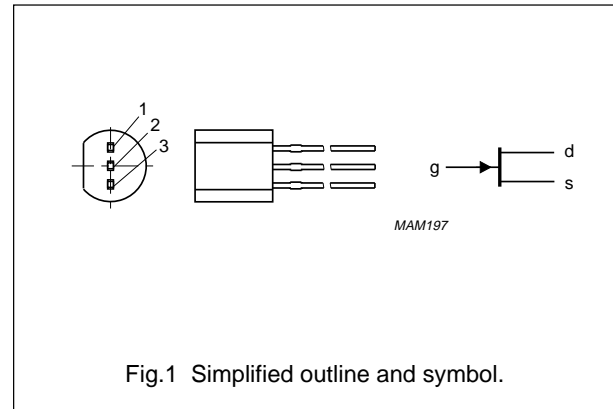

QUICK REFERENCE DATA

SYMBOL	PARAMETER	CONDITIONS	MIN.	MAX.	UNIT
V_{DS}	drain-source voltage		–	± 25	V
$V_{GS(off)}$	gate-source cut-off voltage	$I_D = 1 \mu A; V_{DS} = 5 V$			
	J108		–3	–10	V
	J109		–2	–6	V
	J110		–0.5	–4	V
I_{DSS}	drain current	$V_{GS} = 0; V_{DS} = 5 V$			
	J108		80	–	mA
	J109		40	–	mA
	J110		10	–	mA
P_{tot}	total power dissipation	up to $T_{amb} = 50 \text{ }^\circ\text{C}$	–	400	mW

N-channel silicon junction FETs

J108; J109; J110

LIMITING VALUES

In accordance with the Absolute Maximum Rating System (IEC 134).

SYMBOL	PARAMETER	CONDITIONS	MIN.	MAX.	UNIT
V_{DS}	drain-source voltage		–	±25	V
V_{GSO}	gate-source voltage	open drain	–	–25	V
V_{GDO}	gate-drain voltage	open source	–	–25	V
I_G	forward gate current (DC)		–	50	mA
P_{tot}	total power dissipation	up to $T_{amb} = 50\text{ °C}$	–	400	mW
T_{stg}	storage temperature		–65	150	°C
T_j	operating junction temperature		–	150	°C

THERMAL CHARACTERISTICS

SYMBOL	PARAMETER	VALUE	UNIT
$R_{th\ j-a}$	thermal resistance from junction to ambient	250	K/W

STATIC CHARACTERISTICS $T_j = 25\text{ °C}$; unless otherwise specified.

SYMBOL	PARAMETER	CONDITIONS	MIN.	TYP.	MAX.	UNIT
$V_{(BR)GSS}$	gate-source breakdown voltage	$I_G = -1\ \mu\text{A}$; $V_{DS} = 0$	–	–	–25	V
V_{GSoff}	gate-source cut-off voltage	$I_D = 1\ \mu\text{A}$; $V_{DS} = 5\text{ V}$				V
	J108		–3	–	–10	V
	J109		–2	–	–6	V
	J110		–0.5	–	–4	V
I_{DSS}	drain current	$V_{GS} = 0$; $V_{DS} = 15\text{ V}$				mA
	J108		80	–	–	mA
	J109		40	–	–	mA
	J110		10	–	–	mA
I_{GSS}	gate leakage current	$V_{GS} = -15\text{ V}$; $V_{DS} = 0$	–	–	–3	nA
I_{DSX}	drain-source cut-off current	$V_{GS} = -10\text{ V}$; $V_{DS} = 5\text{ V}$	–	–	3	nA
R_{DSon}	drain-source on-state resistance	$V_{GS} = 0$; $V_{DS} = 100\text{ mV}$				Ω
	J108		–	–	8	Ω
	J109		–	–	12	Ω
	J110		–	–	18	Ω

N-channel silicon junction FETs

J108; J109; J110

DYNAMIC CHARACTERISTICS $T_j = 25\text{ }^\circ\text{C}$; unless otherwise specified.

SYMBOL	PARAMETER	CONDITIONS	TYP.	MAX.	UNIT
C_{is}	input capacitance	$V_{DS} = 0$; $V_{GS} = -10\text{ V}$; $f = 1\text{ MHz}$	15	30	pF
		$V_{DS} = 0$; $V_{GS} = 0$; $f = 1\text{ MHz}$; $T_{amb} = 25\text{ }^\circ\text{C}$	50	85	pF
C_{rs}	reverse transfer capacitance	$V_{DS} = 0$; $V_{GS} = -10\text{ V}$; $f = 1\text{ MHz}$	8	15	pF
Switching times; see Fig.2					
t_d	delay time	note 1	2	–	ns
t_{on}	turn-on time		4	–	ns
t_s	storage time		4	–	ns
t_{off}	turn-off time		6	–	ns

Note

1. Test conditions for switching times are as follows:

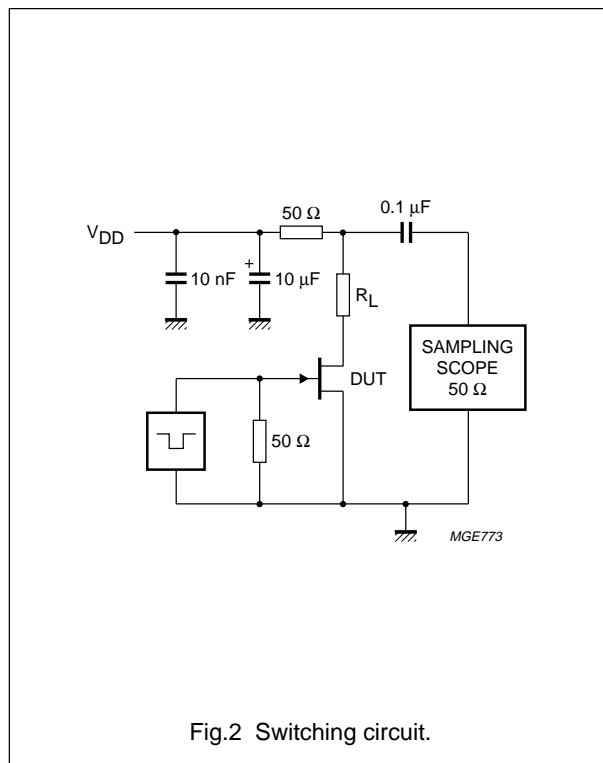
 $V_{DD} = 1.5\text{ V}$; $V_{GS} = 0$ to V_{GSoff} (all types) $V_{GSoff} = -12\text{ V}$; $R_L = 100\text{ }\Omega$ (J108) $V_{GSoff} = -7\text{ V}$; $R_L = 100\text{ }\Omega$ (J109) $V_{GSoff} = -5\text{ V}$; $R_L = 100\text{ }\Omega$ (J110).

N-channel silicon junction FETs

J108; J109; J110

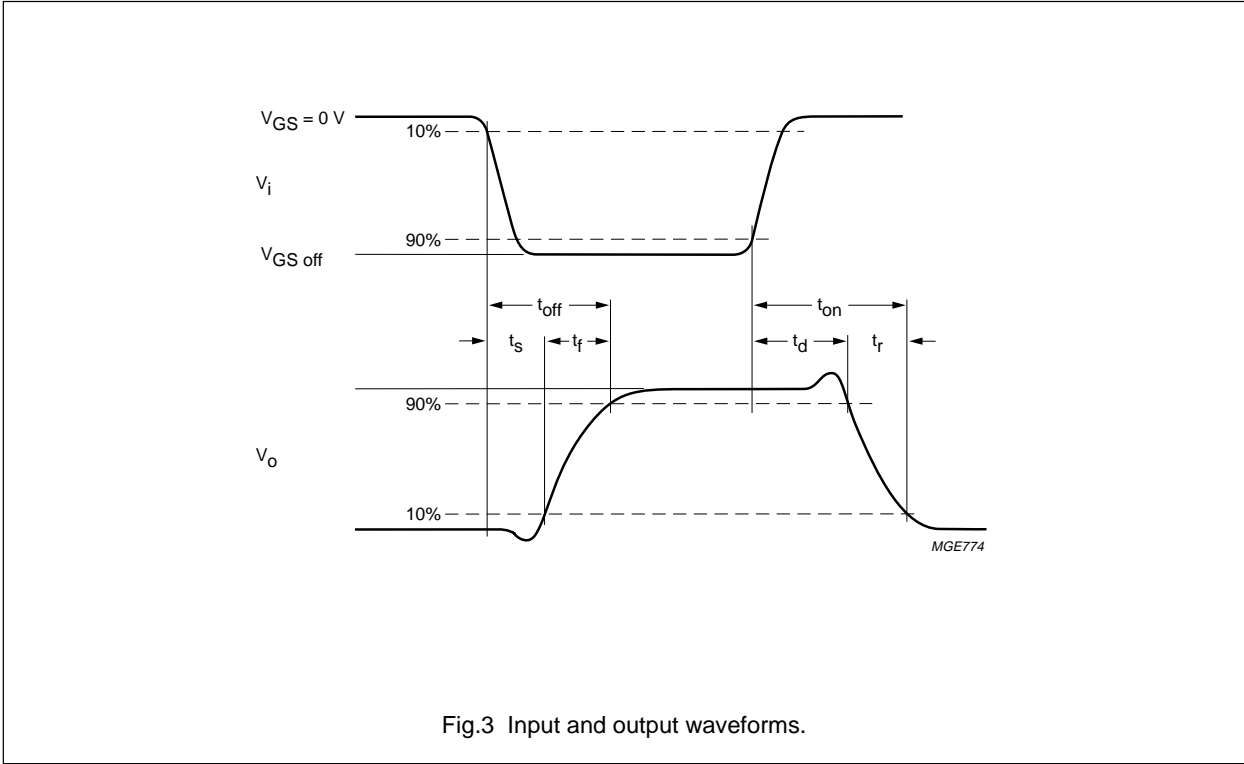
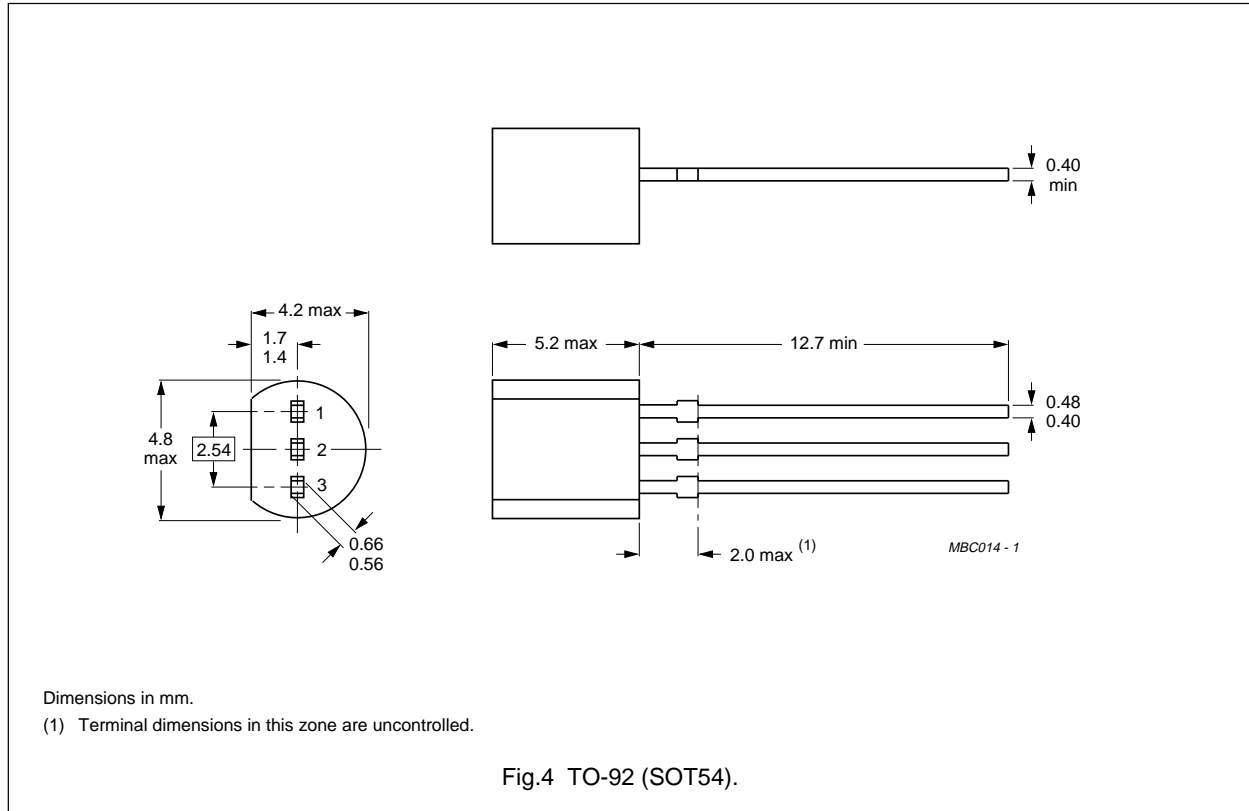

Fig.3 Input and output waveforms.

N-channel silicon junction FETs

J108; J109; J110

PACKAGE OUTLINE



N-channel silicon junction FETs

J108; J109; J110

DEFINITIONS

Data Sheet Status	
Objective specification	This data sheet contains target or goal specifications for product development.
Preliminary specification	This data sheet contains preliminary data; supplementary data may be published later.
Product specification	This data sheet contains final product specifications.
Limiting values	
Limiting values given are in accordance with the Absolute Maximum Rating System (IEC 134). Stress above one or more of the limiting values may cause permanent damage to the device. These are stress ratings only and operation of the device at these or at any other conditions above those given in the Characteristics sections of the specification is not implied. Exposure to limiting values for extended periods may affect device reliability.	
Application information	
Where application information is given, it is advisory and does not form part of the specification.	

LIFE SUPPORT APPLICATIONS

These products are not designed for use in life support appliances, devices, or systems where malfunction of these products can reasonably be expected to result in personal injury. Philips customers using or selling these products for use in such applications do so at their own risk and agree to fully indemnify Philips for any damages resulting from such improper use or sale.