



IQS213EV03 Evaluation Kit User Manual

IQ Switch® - ProxSense® Series

Table of Contents

1	INTRODUCTION.....	1
2	STANDALONE/DATASTREAMING EV-KIT	1
3	STANDALONE OPERATION	2
4	DATASTREAMING OPERATION.....	3
5	REFERENCE DESIGNS.....	4

1 Introduction

This user manual describes the operation of the IQS213EV03 Evaluation Kit. The EV-Kit is manufactured in five parts, consisting of the mainboard device, and four separate swipe plug-in module boards. To visualise raw data from the EV-Kit, the main board can be interfaced to any personal computer with USB support, and IQS213 software GUI. The purpose of the IQS213EV03 EV-Kit is to help application and development engineers in evaluating the IQS213 proximity, touch and swipe sensor, in both self-capacitance and projected capacitance modes.



Figure 2.1 IQS213EV03 EV-Kit

- Used in Data Streaming Mode: EV-KIT requires Mini-USB cable
- Powered by supplied battery, or by Mini-USB cable

2 Standalone/Datastreaming EV-Kit

Figure 2.1 illustrates the evaluation kit mainboard and a plug-in swipe module board. Simply plug in the desired swipe module board and turn on the power switch, as depicted in Figure 2.2

Features included in the IQS213EV03:

- Modular design: Connect one of the supplied plug-in modules into the mainboard, to evaluate and compare swipe performance
- Reference designs for IQS213 with user proximity, touch and swipe detection ability
- Four separate module boards to evaluate 2 or 3 channel swipe operation, in either projected capacitance mode, or self-capacitance mode

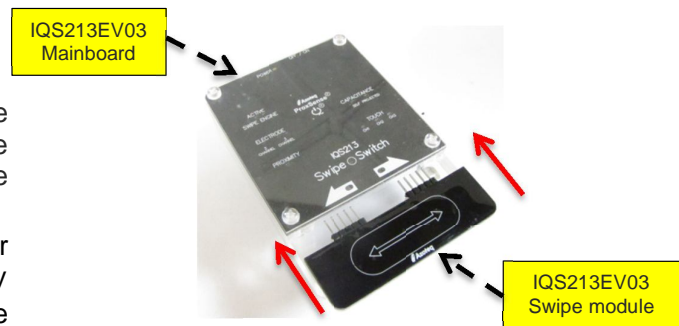

Figure 2.2 IQS213EV03 EV-Kit and Plug-in Module



3 Standalone operation

3.1 Powering on the device

Figure 3.1 illustrates the top view of IQS213EV03 EV-KIT

- Ensure desired swipe module is plugged in (swipe module are hot-swappable once the device is powered on)
- Power on the device by using the slide switch as indicated in figure 3.1

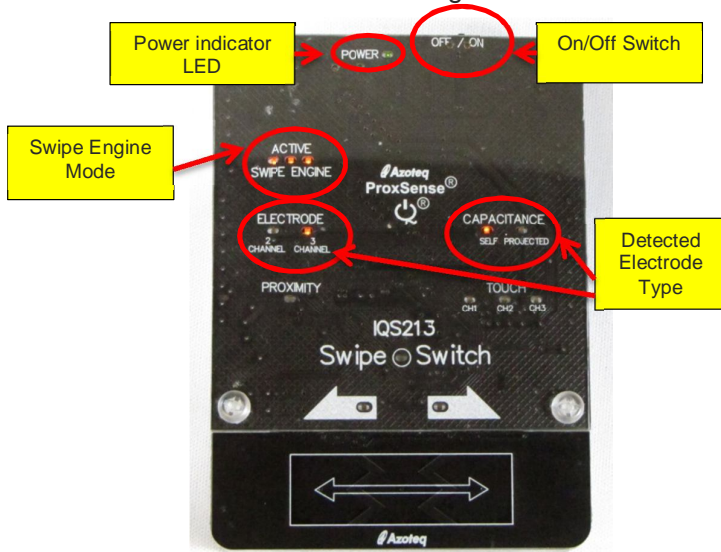

Figure 3.1 IQS213EV03 after power on (top view)

After the device is powered by means of the On/Off slide switch, the system calibrates itself and displays information by means of indicator LEDs.

The power indicator LED lights up in green to indicate the system is powered up. The system automatically detects which swipe module is plugged in and displays this information as illustrated in Figure 3.1.

The Swipe Engine Mode is displayed in the upper left corner by means of three indicator LEDs (please see the IQS213 datasheets for information on configuring the Swipe Engine Mode).

3.2 Device operation

- Slide over the SwipeSwitch™ from left to right, or from right to left to bring the device out of standby mode

The Swipe Active indicator will light up as illustrated in Figure 3.2.

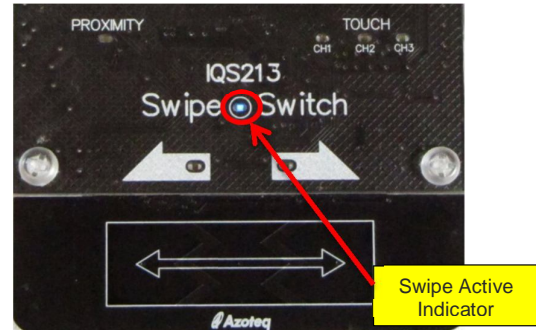

Figure 3.2 IQS213EV03 Swipe Active Indicator

In active mode the device will indicate touch detection on each corresponding channel by means of the touch detection indicator LEDs as illustrated in Figure 3.3.

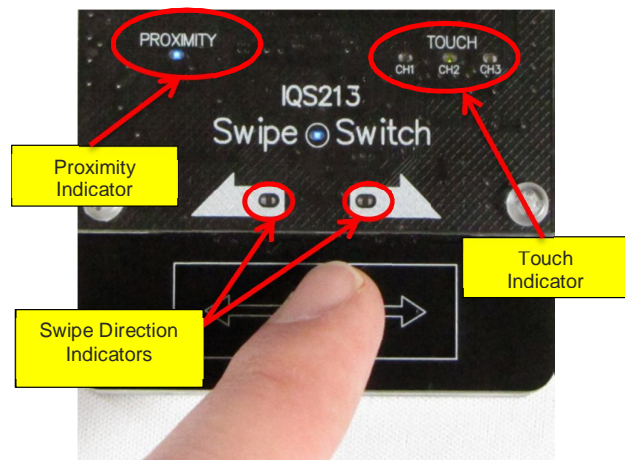

Figure 3.3 Swipe Mode Active

The swipe direction will be indicated by the swipe direction indicator LEDs as depicted in Figure 3.3.

When the swipe is completed the corresponding LED (left or right), will pulse once and turn off again indicating a successful swipe detection.



4 Datastreaming Operation

For operation in data streaming mode, it is necessary to interface the IQS213EV03 EV-Kit to a personal computer by means of a Mini-

USB cable. The IQS213 GUI software is used to stream and visualize data from the IQS213EV03 EV-Kit in real-time.

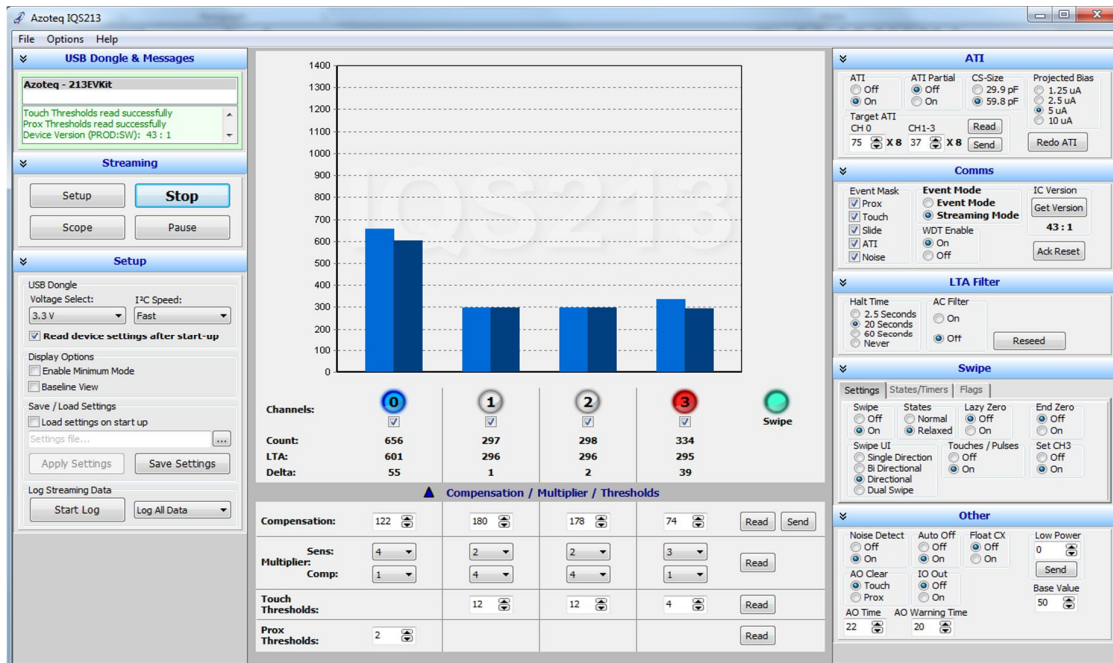

Figure 4.1 IQS213 Graphical User Interface

The IQS213 Software GUI is available from the Azoteq website at www.azoteq.com.

- Install the IQS213 GUI software
- Plug in the desired module into the Mainboard
- Connect the Mainboard to a personal computer with Mini-USB cable
- Run the IQS213 Software GUI and Click on “Start”

The GUI display is illustrated in Figure 3.3 where channel 3 shows a valid touch, and proximity is detected on all other channels.

Important Note: The IQS213 GUI User Guide contains additional information and operating instructions and is available for download at www.azoteq.com.



5 Reference Designs

5.1 IQS213 Self-Capacitance Swipe Reference Design

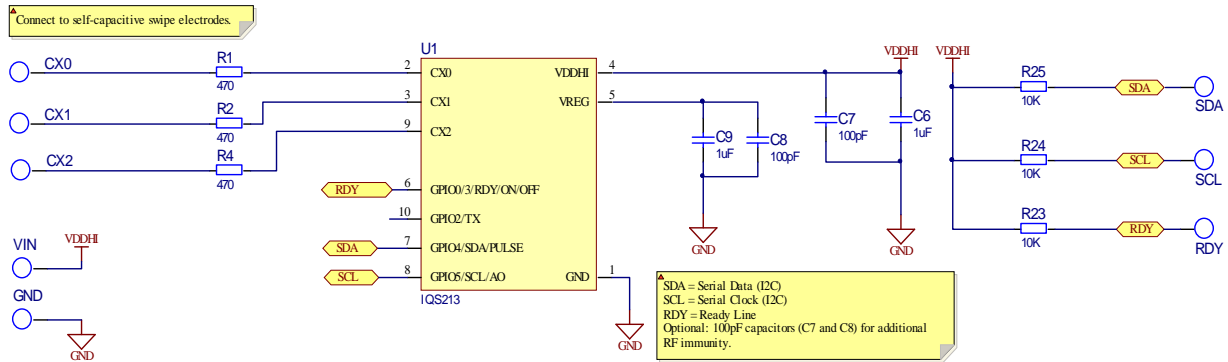

Figure 5.1 IQS213 Self Capacitance Mode Reference design

5.2 IQS213 Projected Capacitance Swipe Reference Design

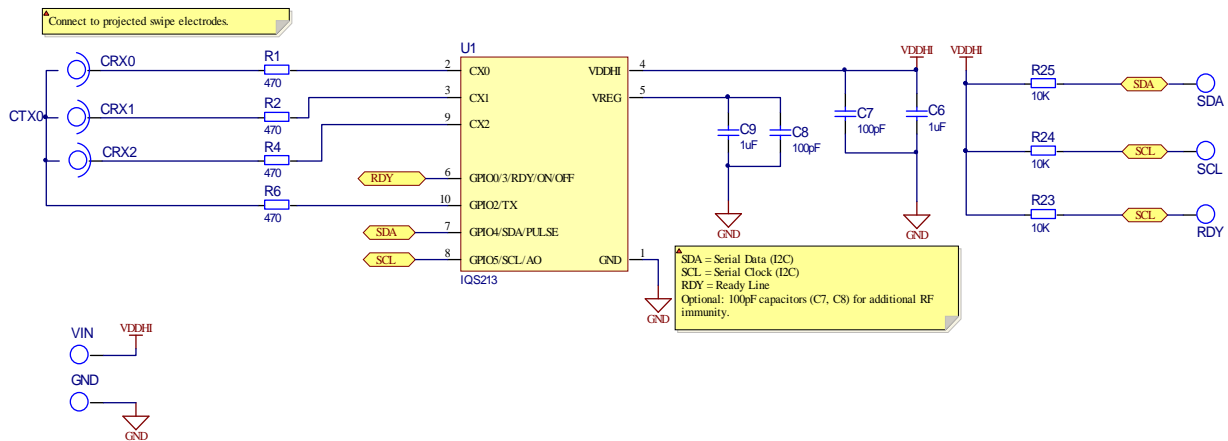

Figure 5.2 IQS213 Projected Mode Reference design

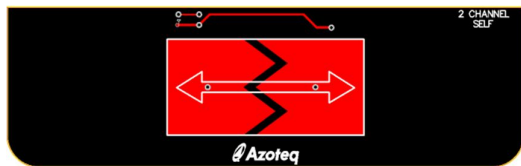

Figure 5.3 2-Channel Self Capacitive

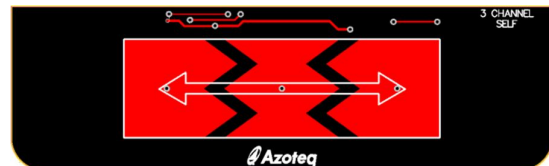

Figure 5.4 3-Channel Self Capacitive

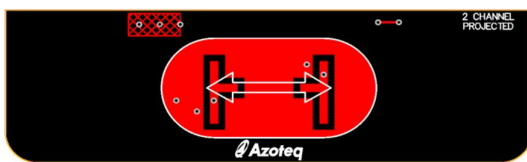

Figure 5.5 2-Channel Projected

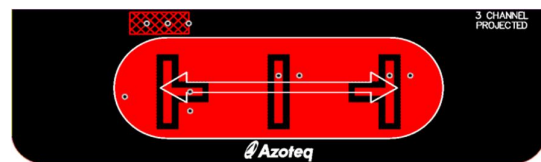



Figure 5.6 3-Channel Projected



The following patents relate to the device or usage of the device: US 6,249,089 B1, US 6,621,225 B2, US 6,650,066 B2, US 6,952,084 B2, US 6,984,900 B1, US 7,084,526 B2, US 7,084,531 B2, US 7,119,459 B2, US 7,265,494 B2, US 7,291,940 B2, US 7,329,970 B2, US 7,336,037 B2, US 7,443,101 B2, US 7,466,040 B2, US 7,498,749 B2, US 7,528,508 B2, US 7,755,219 B2, US 7,772,781, US 7,781,980 B2, US 7,915,765 B2, EP 1 120 018 B1, EP 1 206 168 B1, EP 1 308 913 B1, EP 1 530 178 B1, ZL 99 8 14357.X, AUS 761094

IQ Switch®, ProxSense®, LightSense™, AirButton®, SwipeSwitch™ and the  logo are trademarks of Azoteq.

The information in this Datasheet is believed to be accurate at the time of publication. Azoteq assumes no liability arising from the use of the information or the product. The applications mentioned herein are used solely for the purpose of illustration and Azoteq makes no warranty or representation that such applications will be suitable without further modification, nor recommends the use of its products for application that may present a risk to human life due to malfunction or otherwise. Azoteq products are not authorized for use as critical components in life support devices or systems. No licenses to patents are granted, implicitly or otherwise, under any intellectual property rights. Azoteq reserves the right to alter its products without prior notification. For the most up-to-date information, please refer to www.azoteq.com.

WWW.AZOTEQ.COM

ProxSenseSupport@azoteq.com