

TQM8M9076

0.05-4 GHz Digital Variable Gain Amplifier

Applications

- Wireless Infrastructure
- Fixed Wireless
- Microwave and Satellite Radio
- General Purpose Wireless

Product Features

- Integrates DSA + Amp Functionality
- 50-4000 MHz Broadband Performance
- 19.3 dB Gain @ 2.14 GHz
- 2.9 dB Noise Figure @ max gain setting
- +21.5 dBm P1dB
- +38.5 dBm OIP3
- +5 V Supply Voltage
- 125 mA Operating Current
- MTTF > 1000 Years

General Description

The TQM8M9076 is a digitally controlled variable gain amplifier (DVGA) with a broadband frequency range of 50 to 4000 MHz. The DVGA features high linearity and low noise while providing digital variable gain with a 31.5 dB of range in 0.5 dB steps through a 6-bit serial mode control interface.

The TQM8M9076 integrates a high performance digital step attenuator followed by a high linearity, broadband gain block. The input and output of the individual stages are accessible with external pins to allow for optimization of performance at any sub-band across the DVGA's 0.05 to 4.0 GHz operating frequency range.

The TQM8M9076 is packaged in a RoHS-compliant, compact 5x5 mm surface-mount leadless package. Superior thermal design allows the product to have a minimum MTTF rating of 1000 years at a mounting temperature of +85° C.

The TQM8M9076 is targeted for use in wireless infrastructure, point-to-point, or can be used for any general purpose wireless application.

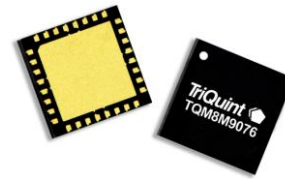

32-pin 5x5mm leadless SMT package

Functional Block Diagram

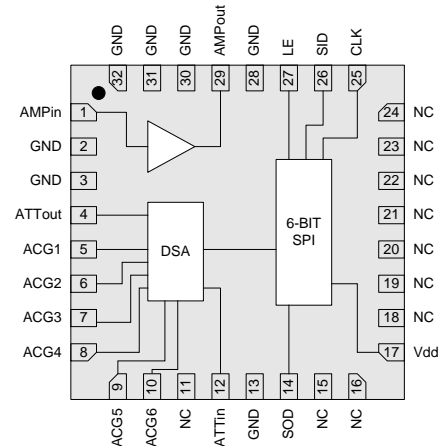

Pin Configuration

Pin #	Symbol
1	Ampin
2, 3, 13, 28, 30, 31, 32	GND (Ground)
4	ATTout
5, 6, 7, 8, 9, 10	ACG1-6
11, 15, 16, 18-24	NC (No Connect)
14	SOD
12	ATTin
17	Vdd
25	CLK
26	SID
27	LE
29	Ampout
Backside Paddle	RF/DC Ground

Ordering Information

Part No.	Description
TQM8M9076	Digital Variable Gain Amplifier

TQM8M9076

0.05-4 GHz Digital Variable Gain Amplifier



TQM8M9076-PCB

0.3-4.0 GHz Evaluation Board

Standard T/R size = 2500 pieces on a 13" reel.

TQM8M9076

0.05-4 GHz Digital Variable Gain Amplifier

Specifications

Absolute Maximum Ratings

Parameter	Rating
Storage Temperature	-65 to 150 °C
RF Input Power, CW, 50Ω, T = 25°C	+24 dBm
Supply Voltage (V _{dd})	+6 V
Digital Input Voltage	V _{dd} +0.5 V

Operation of this device outside the parameter ranges given above may cause permanent damage.

Recommended Operating Conditions

Parameter	Min	Typ	Max	Units
V _{dd}	4.75	5	5.25	V
I _{dd}		125		mA
Operating Temp. Range	-40		+85	°C
T _{ch} (for >10 ⁶ hours MTTF)			190	°C

Electrical specifications are measured at specified test conditions. Specifications are not guaranteed over all recommended operating conditions.

Electrical Specifications

Test conditions unless otherwise noted: T_{LEAD}=+25°C, V_{dd}=+5V

Parameter	Conditions	Min	Typical	Max	Units
Operational Frequency Range		50		4000	MHz
Test Frequency			2140		MHz
Gain		18.0	19.5		dB
Gain Control Range			31.5		dB
Gain Accuracy		± (0.3 + 4% of Atten. Setting) Max			dB
Attenuation Step			0.5		dB
Time _{rise / fall}	10% / 90% RF		90		ns
Time _{on} , Time _{off}	50% CTL to 10% / 90% RF		100		ns
Input Return Loss			-13		dB
Output Return Loss			-10		dB
Output P1dB			+22		dBm
Output IP3	See Note 1	+35	+38.5		dBm
Noise Figure	At max gain level		2.9		dB
Supply Voltage			+5		V
Supply Current		100	125	150	mA
Thermal Resistance	Channel to case			38	°C/W

Notes:

- OIP3 measured with two tones at an output power of +3 dBm / tone separated by 1 MHz. The suppression on the largest IM3 product is used to calculate the OIP3 using a 2:1 rule.

TQM8M9076

0.05-4 GHz Digital Variable Gain Amplifier



Serial Control Interface

The TQM8M9076 has a CMOS SPI™ input compatible serial interface. This serial control interface converts the serial data input stream to parallel output word. The input is 3-wire (CLK, LE and SERIN) SPI™ input compatible. At power up, the serial control interface resets device attenuation state to 31.5dB. The 6-bit SERIN word is loaded into the register on rising edge of the CLK, MSB first. When LE is high, CLK is disabled.

SERIN (MSB in First 6-Bit Word) Control Logic Truth Table

Test conditions: 25°C, $V_{dd} = +5V$

6-Bit Control Word to DSA						Attenuation State
LSB			MSB			
D5	D4	D3	D2	D1	D0	
1	1	1	1	1	1	Reference : IL
1	1	1	1	1	0	0.5 dB
1	1	1	1	0	1	1 dB
1	1	1	0	1	1	2 dB
1	1	0	1	1	1	4 dB
1	0	1	1	1	1	8 dB
0	1	1	1	1	1	16 dB
0	0	0	0	0	0	31.5 dB

Any combination of the possible 64 states will provide an attenuation of approximately the sum of bits selected

Serial Control Interface Timing Diagram

CLK is disabled when LE is high

TQM8M9076

0.05-4 GHz Digital Variable Gain Amplifier

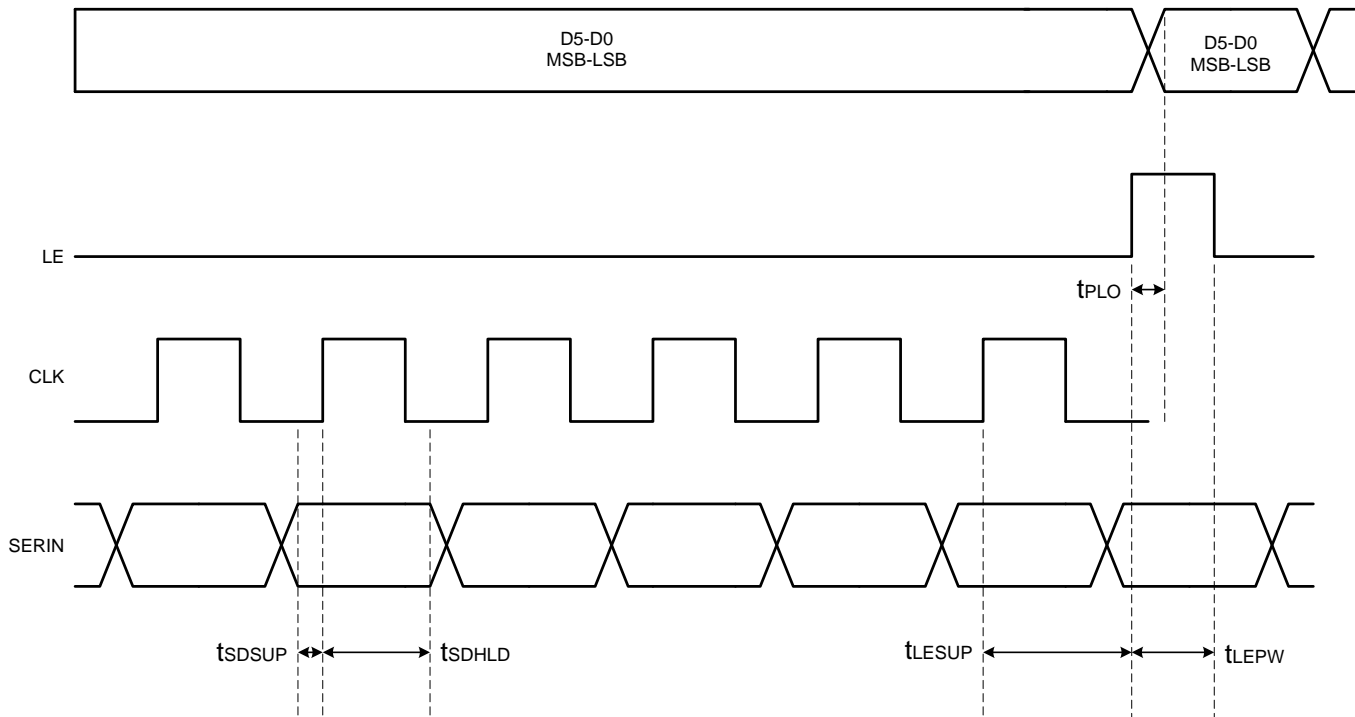

Serial Control Timing Characteristics

Test conditions: 25°C, $V_{dd} = +5V$

Parameter	Condition	Min	Max	Units
Clock Frequency	50% Duty Cycle		10	MHz
LE Setup Time, t_{LESUP}	after last CLK rising edge	10		ns
LE Pulse Width, t_{LEPW}		30		ns
SERIN set-up time, t_{SDSUP}	before CLK rising edge	10		ns
SERIN hold-time, t_{SDHLD}	after CLK rising edge	10		ns
LE Pulse Spacing t_{LE}	LE to LE pulse spacing	630		ns
Propagation Delay t_{PLO}	LE to Parallel output valid		30	ns

Serial Control DC Logic Characteristics

Test conditions: 25°C, $V_{dd} = +5V$

Parameter	Condition	Min	Max	Units
Low State Input Voltage		0	0.8	V
High State Input Voltage		2.1	V_{dd}	V
Output High Voltage	On SEROUT	2.0	V_{dd}	V
Output Low Voltage	On SEROUT	0	0.8	V
Input Current, I_{IH} / I_{IL}	On SERIN, LE and CLK	-10	+10	μA

TQM8M9076

0.05-4 GHz Digital Variable Gain Amplifier

Reference Design 300-4000 MHz

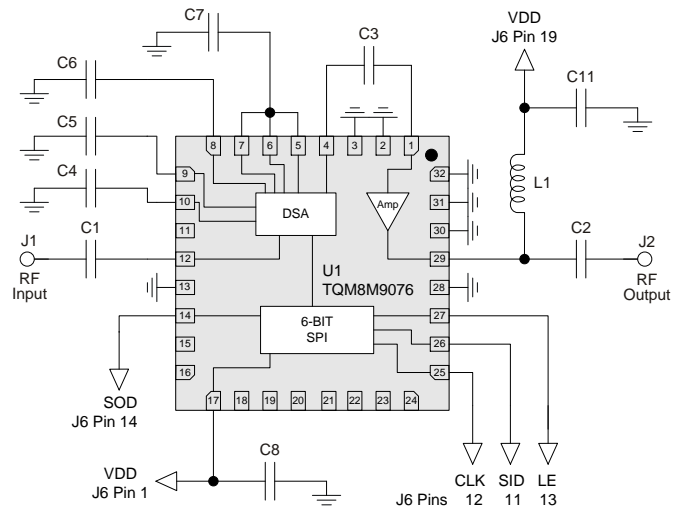
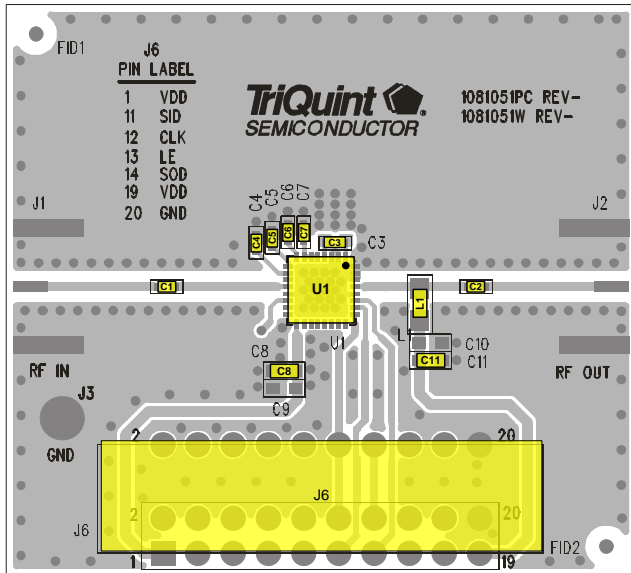

Notes:

1. See PC Board Specifications section for material and stackup.
2. C4, C5, C6 and C7 may be removed for operation above 700 MHz.

Bill of Material

Ref Des	Value	Description	Manufacturer	Part Number
U1	n/a	Digital Variable Gain Amp	TriQuint	TQM8M9076
L1	68 nH	Inductor, 0603	various	
C1, C2, C3	68 pF	Capacitor, 0402	various	
C4, C5, C6, C7	330 pF	Capacitor, 0402	various	
C8	1000 pF	Capacitor, 0603	various	
C11	0.01 uF	Capacitor, 0603	various	

TQM8M9076

0.05-4 GHz Digital Variable Gain Amplifier



Typical Performance

Test Conditions: $V_{dd}=+5$ V, Temp= $+25^{\circ}\text{C}$, $I_{dd}=125$ mA (Typ.)

Frequency	MHz	500	900	2140	2600	3500
Gain ⁽¹⁾	dB	24.1	23.2	19.5	17.6	15.3
Input Return Loss	dB	-15	-19	-13	-11	-9
Output Return Loss	dB	-9	-13	-10	-10	-9
Output P1dB	dBm	+21.8	+21.7	+21.5	+21.5	20.6
Output IP3 (Pout= $+3$ dBm per tone, 1 MHz spacing)	dBm	+38.0	+38.2	+38.5	+38.5	+38.9
Noise Figure ⁽²⁾	dB	1.9	2.0	2.9	3.2	3.4

Notes:

1. Gain values reflect de-embedding of 0.4 dB eval board RF I/O line losses that would not be present in target applications.
2. Noise figure values reflect de-embedding of eval board RF I/O line loss that would not be present in target applications.
3. Performance plots shown below for DVGA maximum gain state.

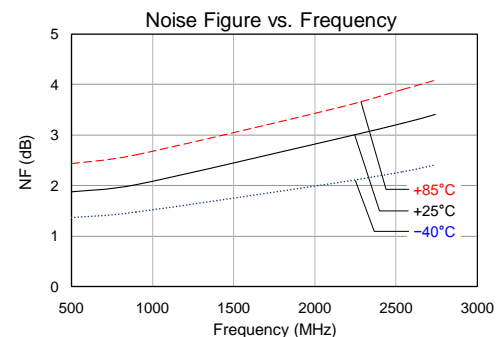
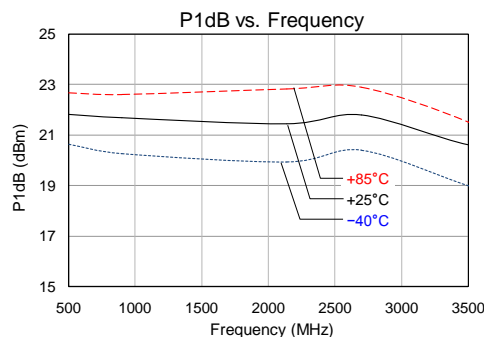
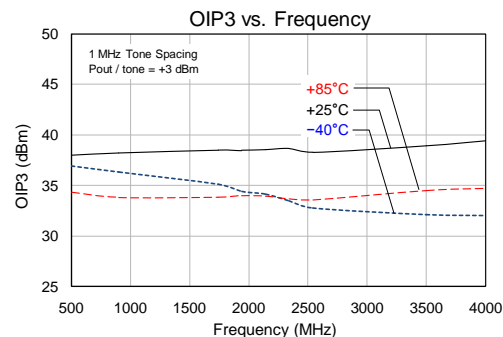
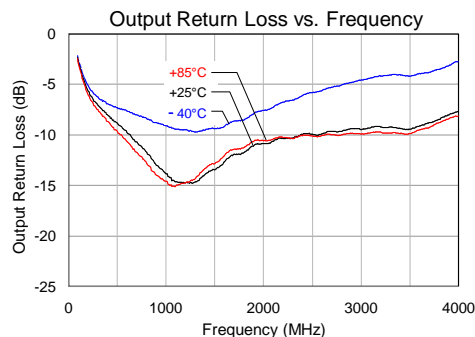
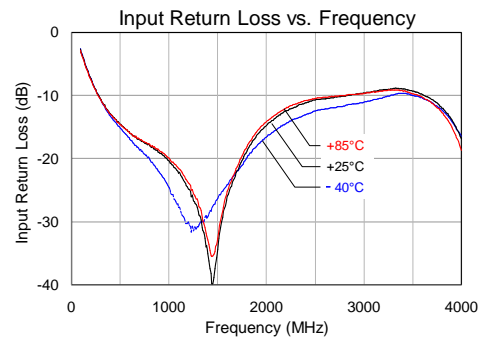
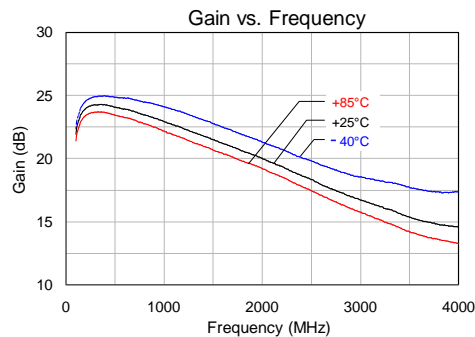

TQM8M9076

0.05-4 GHz Digital Variable Gain Amplifier

Pin Description

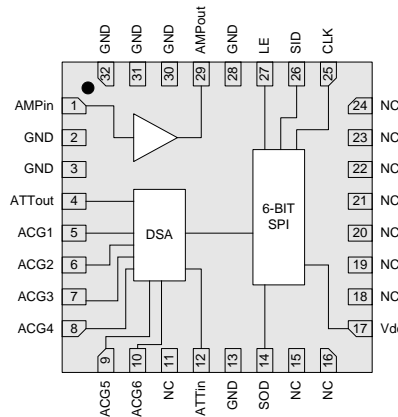

Pin #	Symbol	Description
1	Ampin	Amp RF input
2, 3, 13, 28, 30, 31, 32	GND (Ground)	DC ground
11, 15, 16, 18-24	NC (No Connect)	No electrical connection. Provide land pads for PCB mounting integrity.
29	Ampout	Amp RF output / DC supply
12	ATTin	DSA Input
4	ATTout	DSA Output
5, 6, 7, 8, 9, 10	ACG1-6	Place external capacitor to Ground for applications below 700 MHz.
14	SOD	Serial Data Out
17	Vdd	DC supply
25	CLK	Serial Clock
26	SID	Serial Data In
27	LE	Latch Enable
Backside Paddle	RF/DC Ground	RF/DC ground. Provide recommended via pattern (see page 8) and ensure good solder attach for best thermal and electrical performance.

PC Board Specifications

PCB Material (stackup):

- 1 oz. Cu top layer
- 0.014 inch Nelco N-4000-13
- 1 oz. Cu middle layer 1
- Core Nelco N-4000-13
- 1 oz. Cu middle layer 2
- 0.014 inch Nelco N-4000-13
- 1 oz. Cu bottom layer

Finished board thickness is 0.062±.006

The pad pattern shown has been developed and tested for optimized assembly at TriQuint Semiconductor. The PCB land pattern has been developed to accommodate lead and package tolerances. Since surface mount processes vary from company to company, careful process development is recommended.

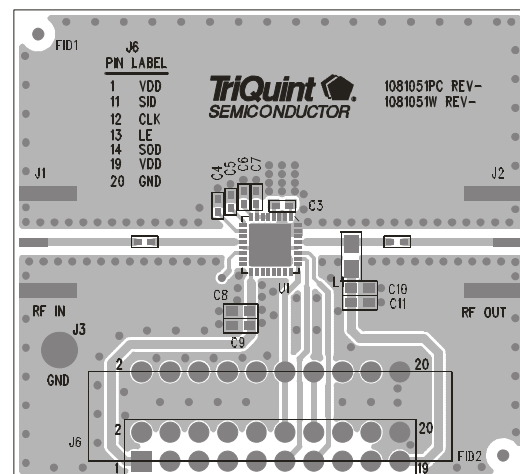

TQM8M9076

0.05-4 GHz Digital Variable Gain Amplifier

Mechanical Information

Package Information & Dimensions

Marking: Part number - TQM8M9076

Year, week, country code - YYWW CCCC

Assembly code - AaXXXX

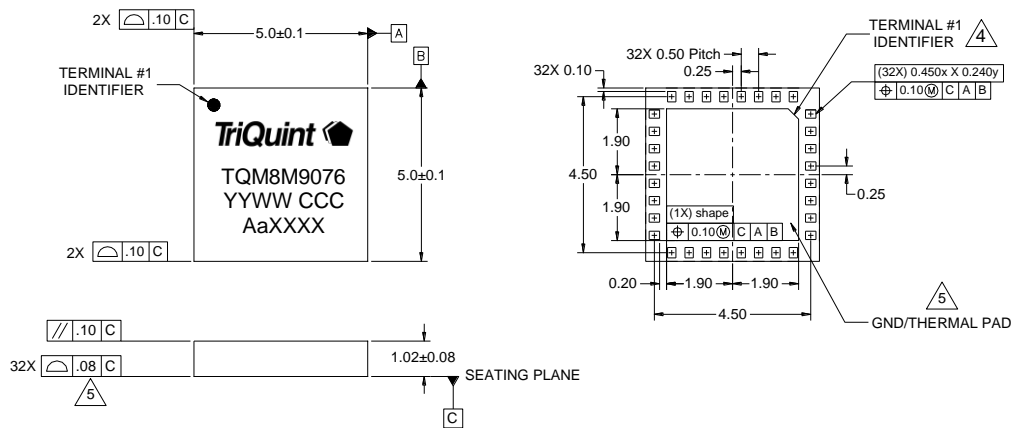

NOTES:

1. All dimensions are in millimeters. Angles are in degrees.
2. Except where noted, this part outline conforms to JEDEC standard MO-270, Issue B (Variation DAE) for extra thin profile, fine pitch, internal stacking module (ISM).
3. Dimension and tolerance formats conform to ASME Y14.4M-1994.
4. The terminal #1 identifier and terminal numbering conform to JESD 95-1 SPP-012.
5. Co-planarity applies to the exposed ground/thermal pad as well as the contact pins.
6. Contact plating: Electrolytic plated Au over Ni

PCB Mounting Pattern

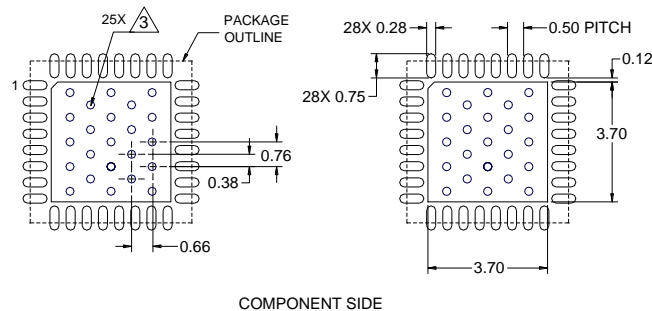

NOTES:

1. All dimensions are in millimeters. Angles are in degrees.
2. Use 1 oz. copper minimum for top and bottom layer metal.
3. Vias are required under the backside paddle of this device for proper RF/DC grounding and thermal dissipation. We recommend a 0.35mm (#80/.0135") diameter bit for drilling via holes and a final plated thru diameter of 0.25mm (0.10").
4. Ensure good package backside paddle solder attach for reliable operation and best electrical performance.
5. Place mounting screws near the part to fasten a back side heat sink.
6. Do not apply solder mask to the back side of the PC board in the heat sink contact region.
7. Ensure that the backside via region makes good physical contact with the heat sink.

TQM8M9076

0.05-4 GHz Digital Variable Gain Amplifier

Product Compliance Information

ESD Information



Caution! ESD-Sensitive Device

ESD Rating: Class 1A
Value: $\geq 250V$ to $< 500V$
Test: Human Body Model (HBM)
Standard: JEDEC Standard JESD22-A114

ESD Rating: Class IV
Value: $> 1000V$
Test: Charged Device Model (CDM)
Standard: JEDEC Standard JESD22-C101

MSL Rating

Level 3 at $+260\text{ }^{\circ}\text{C}$ convection reflow per JEDEC standard IPC/JEDEC J-STD-020.

Solderability

Package Contact Plating: Electrolytic plated Au over Ni

Compatible with both lead-free ($260\text{ }^{\circ}\text{C}$ max. reflow temperature) and tin/lead ($245\text{ }^{\circ}\text{C}$ max. reflow temperature) soldering processes.

RoHS Compliance

This part is compliant with EU 2002/95/EC RoHS directive (Restrictions on the Use of Certain Hazardous Substances in Electrical and Electronic Equipment).

This product also has the following attributes:

- Halogen Free (Chlorine, Bromine)
- Antimony Free
- TBBP-A ($\text{C}_{15}\text{H}_{12}\text{Br}_4\text{O}_2$) Free
- PFOS Free
- SVHC Free

Contact Information

For the latest specifications, additional product information, worldwide sales and distribution locations, and information about TriQuint:

Web: www.triquint.com
Email: info-sales@tqs.com

Tel: +1.503.615.9000
Fax: +1.503.615.8902

For technical questions and application information:

Email: sjapplications.engineering@tqs.com

Important Notice

The information contained herein is believed to be reliable. TriQuint makes no warranties regarding the information contained herein. TriQuint assumes no responsibility or liability whatsoever for any of the information contained herein. TriQuint assumes no responsibility or liability whatsoever for the use of the information contained herein. The information contained herein is provided "AS IS, WHERE IS" and with all faults, and the entire risk associated with such information is entirely with the user. All information contained herein is subject to change without notice. Customers should obtain and verify the latest relevant information before placing orders for TriQuint products. The information contained herein or any use of such information does not grant, explicitly or implicitly, to any party any patent rights, licenses, or any other intellectual property rights, whether with regard to such information itself or anything described by such information.

TriQuint products are not warranted or authorized for use as critical components in medical, life-saving, or life-sustaining applications, or other applications where a failure would reasonably be expected to cause severe personal injury or death.