

Applications

- Repeaters
- Mobile Infrastructure
- Defense / Aerospace
- LTE / WCDMA / CDMA
- General Purpose Wireless
- IF Amplifier, RF Driver Amplifier

Product Features

- 50-4000 MHz
- Flat gain (14.7 ± 0.3 dB) from 0.5 – 3.5 GHz
- +40 dBm Output IP3
- 1.8 dB Noise Figure @ 1900 MHz
- No RF components needed; 50 Ohm Gain Block
- Unconditionally Stable
- +5V Single Supply, 85 mA Current
- SOT-89 Package

General Description

The TQP3M9028 is a cascadable, high linearity gain block amplifier in a low-cost surface-mount package. At 1.9 GHz, the amplifier typically provides 14.7 dB gain, +40 dBm OIP3, and 1.8 dB Noise Figure while only drawing 85 mA current. The device is housed in a leadfree/green/RoHS-compliant industry-standard SOT-89 package.

The TQP3M9028 has the benefit of having excellent gain flatness across a broad range of frequencies. The low noise figure and high linearity performance allows the device to be used in both receiver and transmitter chains for high performance systems. The amplifier is internally matched using a high performance E-pHEMT process and only requires an external RF choke and blocking/bypass capacitors for operation from a single +5V supply. The internal active bias circuit also enables stable operation over bias and temperature variations.

The TQP3M9028 covers the 50-4000 MHz frequency band and is targeted for wireless infrastructure or other applications requiring high linearity and/or low noise figure.



SOT-89 Package

Functional Block Diagram

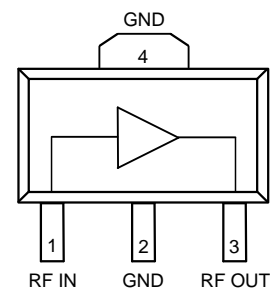

Pin Configuration

Pin No.	Label
1	RF In
3	RF Out / DC Bias
2, 4	Ground

Ordering Information

Part No.	Description
TQP3M9028	High Linearity LNA Gain Block
TQP3M9028-PCB_IF	50-500 MHz Evaluation Board
TQP3M9028-PCB_RF	0.5-4 GHz Evaluation Board

Standard T/R size = 1000 pieces on a 7" reel

Absolute Maximum Ratings

Parameter	Rating
Storage Temperature	-65 to 150°C
RF Input Power, CW, 50Ω, T=25°C	+23 dBm
Supply Voltage (V _{DD})	+7 V
Reverse Supply Voltage	-0.3 V

Operation of this device outside the parameter ranges given above may cause permanent damage.

Recommended Operating Conditions

Parameter	Min	Typ	Max	Units
Supply Voltage (V _{DD})	4.75	5.0	5.25	V
T _{CASE}	-40		+85	°C
T _j for >10 ⁶ hours MTTF			+190	°C

Electrical specifications are measured at specified test conditions. Specifications are not guaranteed over all recommended operating conditions.

Electrical Specifications

Test conditions unless otherwise noted: V_{DD} = +5V, Temp = +25°C, 50 Ω system.

Parameter	Conditions	Min	Typ	Max	Units
Operational Frequency Range		50		4000	MHz
Test Frequency			1900		MHz
Gain		13	14.5	16	dB
Input Return Loss			18		dB
Output Return Loss			19		dB
Output P1dB			+20.7		dBm
Output IP3	P _{out} = +4 dBm/tone, Δf = 1 MHz	+36	+40		dBm
Noise Figure			1.8		dB
Current, I _{DD}			85	100	mA
Thermal Resistance, θ _{jc}	Junction to backside paddle		36.6		°C/W

S-Parameters

Test Conditions: $V_{DD}=+5$ V, $I_{DD}=85$ mA (typ.), $T=+25^{\circ}\text{C}$, unmatched 50 ohm system, calibrated to device leads

Freq (GHz)	S11 (dB)	S11 (ang)	S21 (dB)	S21 (ang)	S12 (dB)	S12 (ang)	S22 (dB)	S22 (ang)
0.05	-17.781	-79.977	16.426	168.24	-19.626	4.3045	-19.220	-103.67
0.1	-20.687	-111.11	15.710	165.75	-19.125	-0.3832	-19.244	-133.67
0.2	-23.728	-139.82	15.333	161.88	-18.801	-5.7231	-19.718	-156.97
0.4	-26.055	-167.83	15.114	150.42	-19.148	-15.433	-20.556	179.38
0.6	-27.432	-174.22	15.068	138.49	-19.086	-24.010	-22.047	170.39
0.8	-28.336	175.58	14.970	124.69	-19.086	-32.722	-22.058	163.66
1.0	-28.090	168.62	14.889	112.00	-19.259	-42.486	-23.024	152.72
1.2	-27.851	173.63	14.837	98.392	-19.196	-50.978	-24.702	147.54
1.4	-27.744	-176.1	14.787	85.391	-19.461	-59.544	-27.618	150.45
1.6	-25.498	-170.21	14.785	71.784	-19.643	-67.665	-30.371	178.07
1.8	-23.299	-171.85	14.681	58.795	-19.718	-76.829	-30.117	-137.55
2.0	-21.873	-177.68	14.742	45.335	-19.786	-86.241	-24.898	-137.73
2.2	-19.991	174.69	14.585	31.380	-20.202	-94.784	-21.473	-136.81
2.4	-18.395	168.24	14.660	17.730	-20.964	-105.89	-18.570	-137.28
2.6	-16.954	156.32	14.540	3.3697	-20.584	-113.76	-16.815	-144.20
2.8	-15.635	143.92	14.468	-10.871	-21.081	-123.83	-15.001	-146.29
3.0	-14.526	132.69	14.390	-25.665	-21.170	-134.66	-13.630	-160.04
3.2	-13.585	121.19	14.321	-40.604	-21.463	-143.32	-12.590	-169.39
3.4	-13.396	109.54	14.295	-55.994	-21.608	-153.10	-11.447	-179.44
3.6	-13.267	95.204	14.103	-71.813	-22.114	-164.82	-10.288	168.78
3.8	-13.490	73.954	14.022	-88.474	-22.248	-174.45	-9.8699	161.57
4.0	-13.580	51.354	13.694	-105.82	-22.604	175.38	-9.6061	156.49

TQP3M9028-PCB_RF Evaluation Board (500–4000 MHz)

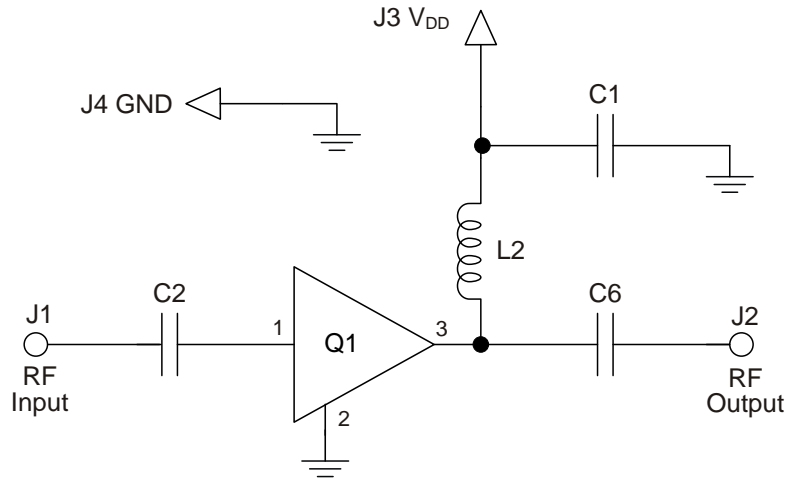
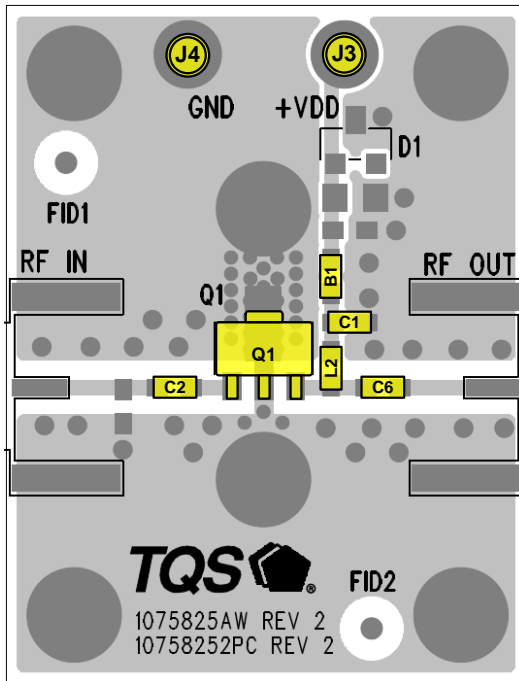

Notes:

1. See PC Board Layout, page 8 for more information.
2. Components shown on the silkscreen but not on the schematic are not used.
3. B1 (0 Ω jumper) may be replaced with copper trace in the target application layout.
4. The recommended component values are dependent upon the frequency of operation.
5. All components are of 0603 size unless stated on the schematic.

Bill of Material – TQP3M9028-PCB_RF

Reference Des.	Value	Description	Manuf.	Part Number
n/a	n/a	Printed Circuit Board	TriQuint	1075825
Q1	n/a	High Linearity LNA Gain Block	TriQuint	TQP3M9028
C2, C6	100 pF	CAP, 0603, 5%, 100V, NPO/COG	various	
C1	0.01 uF	CAP, 0603, 5%, 50V, X7R	various	
L2	68 nH	IND, 0603, 5%	CoilCraft	0603CS-68NXJL
B1	0 Ω	RES, 0603	various	
L1, D1, C3, C4	DNP	n/a	n/a	n/a

Note: Performances can be optimized at frequency of interest by using recommended component values shown in the table below. Inductors are wirewound Coilcraft.

Reference Designation	Frequency (MHz)			
	500	2000	2500	3500
C2, C6	100 pF	22 pF	22 pF	22 pF
L2	82 nH	22 nH	18 nH	15 nH

Typical Performance – TQP3M9028-PCB_RF

Test conditions unless otherwise noted: $V_{DD} = +5V$, $I_{DD} = 85\text{ mA}$ (typ.), Temp = $+25^\circ\text{C}$

Parameter	Typical Value							Units
Frequency	500	900	1900	2700	3500	4000		MHz
Gain	15.2	15.1	14.7	14.4	14.6	14.2		dB
Input Return Loss	19	24	18	16	17	12		dB
Output Return Loss	17.5	21	19	14	16	16.5		dB
Output P1dB	+21.3	+21.4	+20.7	+19.8	+19.6	+18.1		dBm
OIP3 ⁽¹⁾	+40.6	+40.1	+40.3	+36.2	+33.2	+29		dBm
Noise figure ⁽²⁾	1.6	1.7	1.8	2.0	2.3	2.6		dB

Notes:

- OIP3 measured with two tones at an output power of +4 dBm / tone separated by 1 MHz.
- Noise figure data shown in the table above is de-embedded from the eval board loss.

Performance Plots – TQP3M9028-PCB_RF

Test conditions unless otherwise noted: $V_{DD} = +5V$, $I_{DD} = 85\text{ mA}$ (typ.), Temp = $+25^\circ\text{C}$

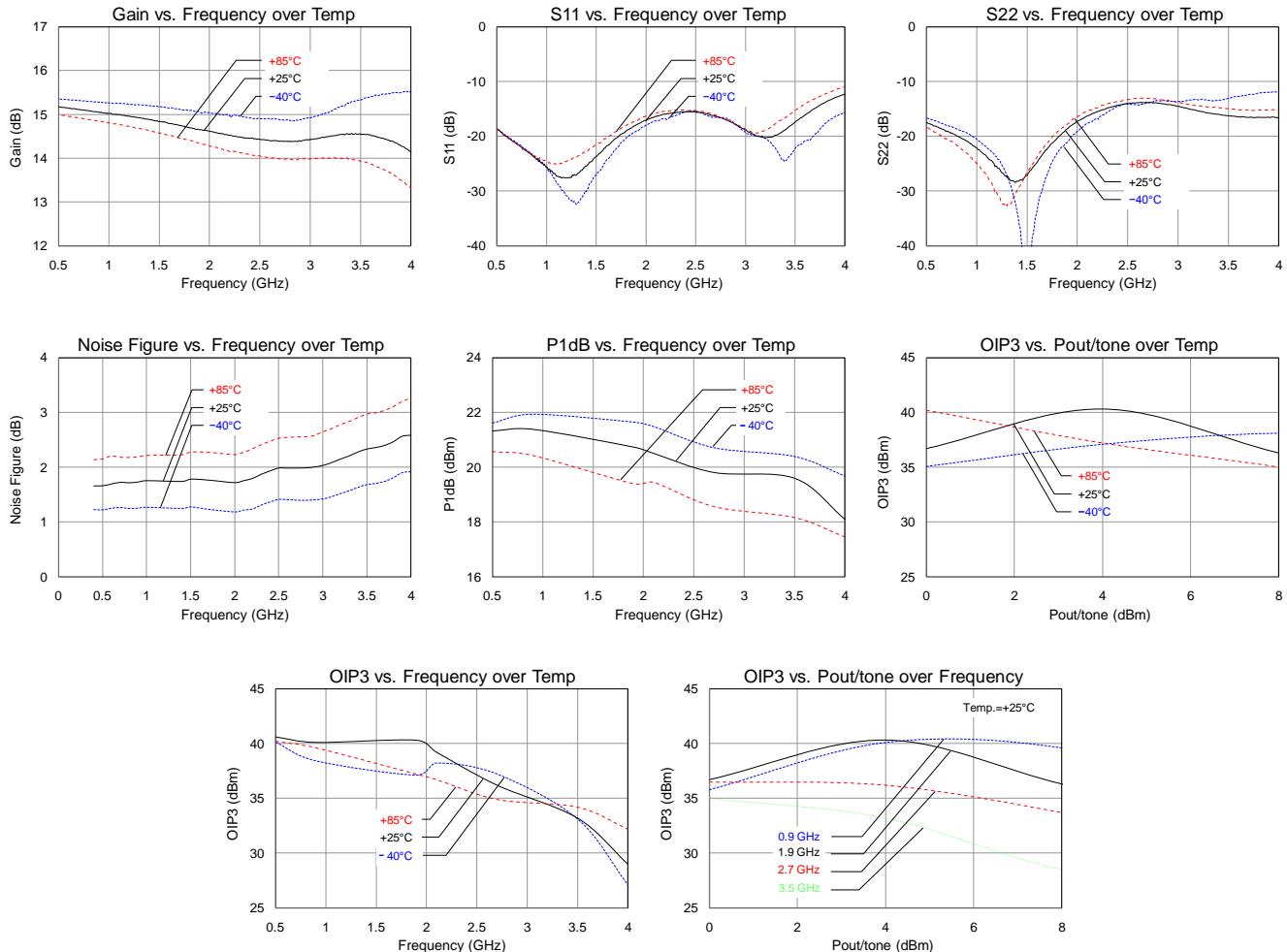

TQP3M9028-PCB_IF Evaluation Board (50–500 MHz)

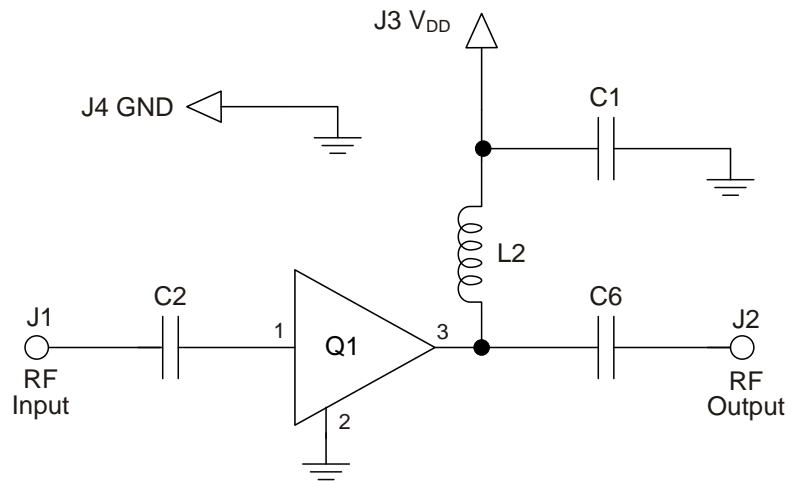
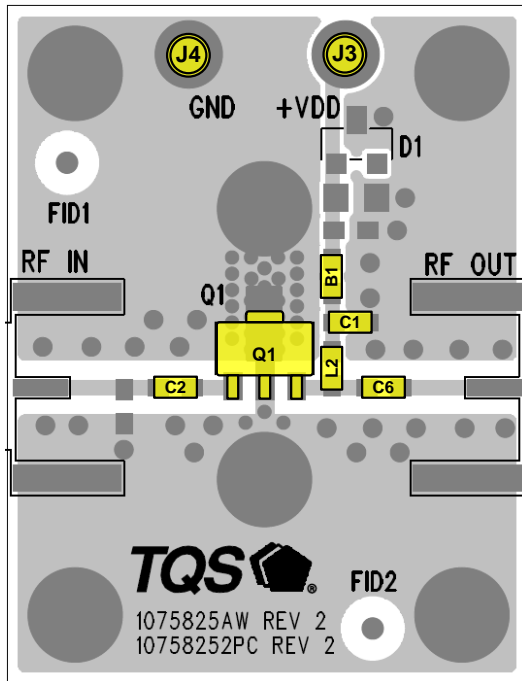

Notes:

1. See PC Board Layout, page 8 for more information.
2. Components shown on the silkscreen but not on the schematic are not used.
3. B1 (0 Ω jumper) may be replaced with copper trace in the target application layout.
4. The recommended component values are dependent upon the frequency of operation.
5. All components are of 0603 size unless stated on the schematic.

Bill of Material – TQP3M9028-PCB_IF

Reference Des.	Value	Description	Manuf.	Part Number
n/a	n/a	Printed Circuit Board	TriQuint	1075825
Q1	n/a	High Linearity LNA Gain Block	TriQuint	TQP3M9028
C2, C6	1000 pF	CAP, 0603, 5%, 50V, X7R	various	
C1	0.01 uF	CAP, 0603, 5%, 50V, X7R	various	
L2	330 nH	IND, 0603, 5%	CoilCraft	0603CS-R33XJL
B1	0 Ω	RES, 0603	various	
L1, D1, C3, C4	DNP	n/a	n/a	n/a

Typical Performance – TQP3M9028-PCB_IF

Test conditions unless otherwise noted: $V_{DD} = +5V$, $I_{DD} = 85$ mA (typ.), Temp = $+25^{\circ}C$

Parameter	Conditions	Typical Values				Units
Frequency		70	100	200	500	MHz
Gain		15.8	15.5	15.3	15.2	dB
Input Return Loss		13	15	20	25	dB
Output Return Loss		23	23	22	20.5	dB
Output P1dB		+20.6	+20.6	+21.0	+21.2	dBm
OIP3	Pout = +6 dBm/tone, $\Delta f = 1$ MHz	+40.3	+40.5	+41.9	+39.9	dBm
Noise figure ⁽¹⁾		1.7	1.7	1.7	1.7	dB

Notes:

- Noise figure data shown in the table above is de-embedded from the eval board loss.

Performance Plots – TQP3M9028-PCB_IF

Test conditions unless otherwise noted: $V_{DD} = +5V$, $I_{DD} = 85$ mA (typ.), Temp = $+25^{\circ}C$

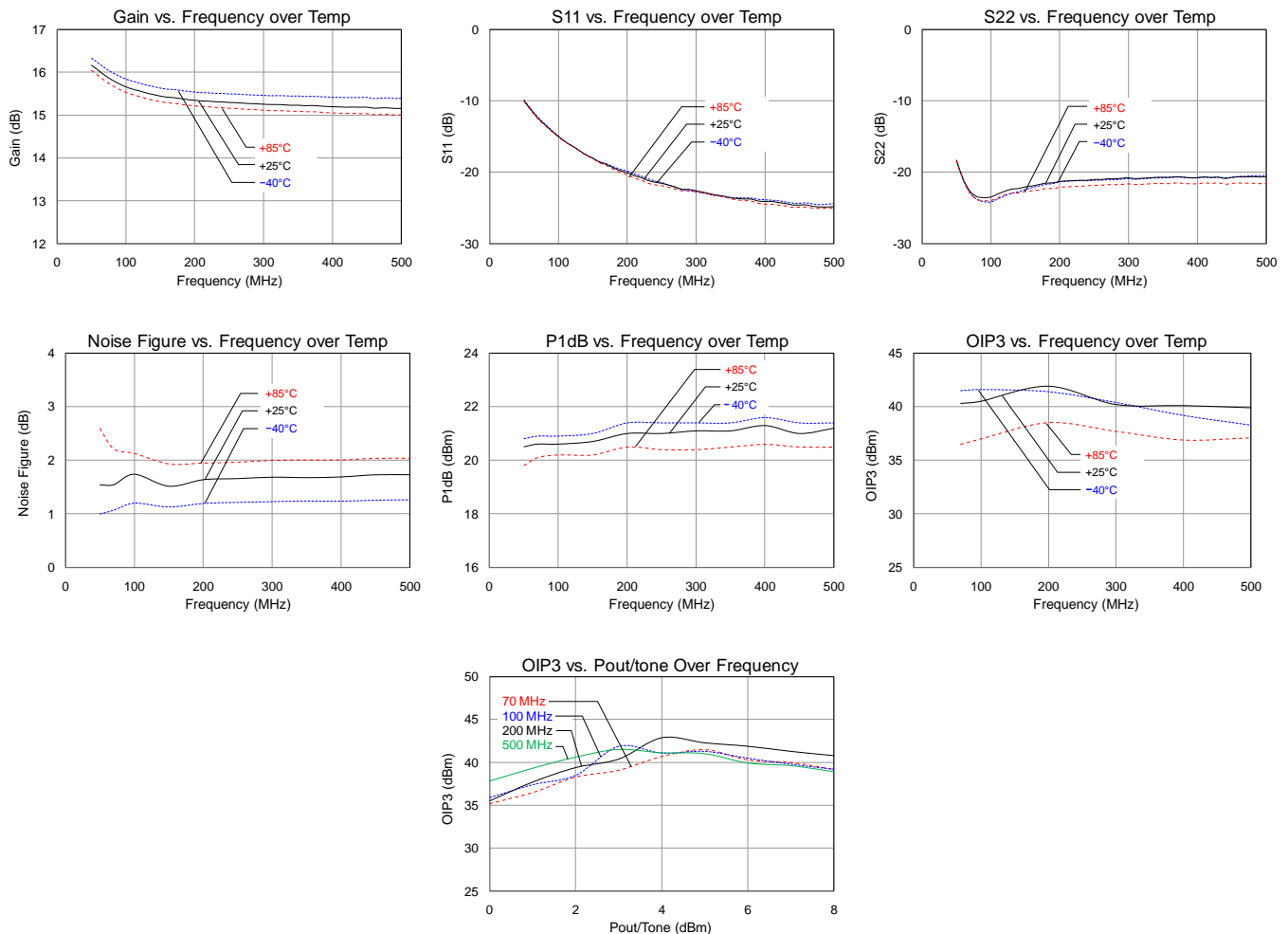

Pin Configuration and Description

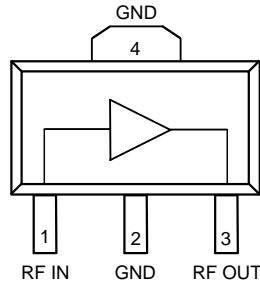

Pin No.	Label	Description
1	RF In	Input, matched to 50 ohms. External DC Block is required.
3	RF Out / DC Bias	Output, matched to 50 ohms, External DC Block is required and supply voltage
2, 4	Ground	RF/DC Ground Connection

Evaluation Board PCB Information

TriQuint PCB 1075825 Material and Stack-up

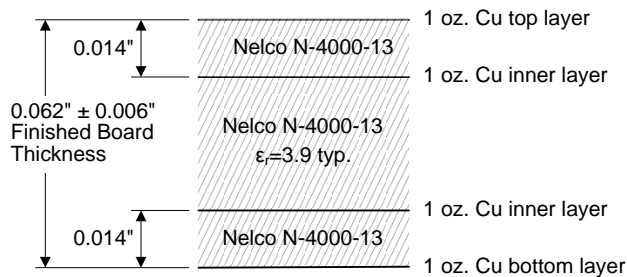

50 ohm line dimensions: width = 0.029", spacing = 0.035"

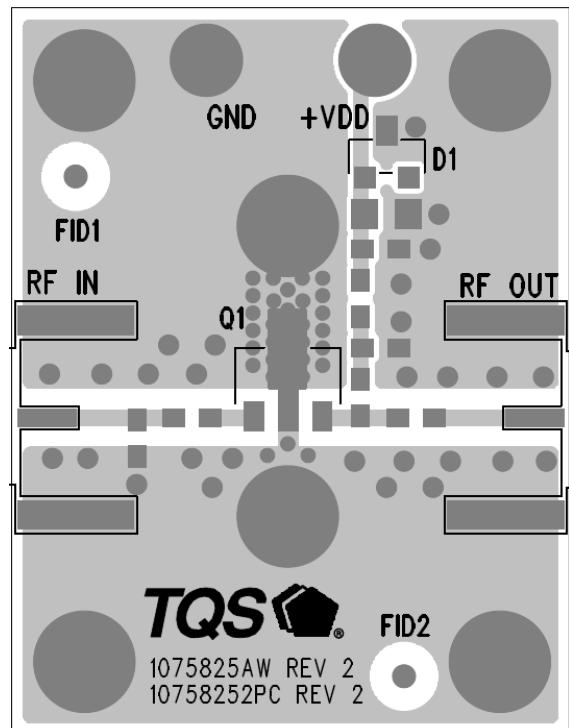

Mechanical Information

Package Marking and Dimensions

Marking: Part number – 3M9028
 Lot code – XXXX

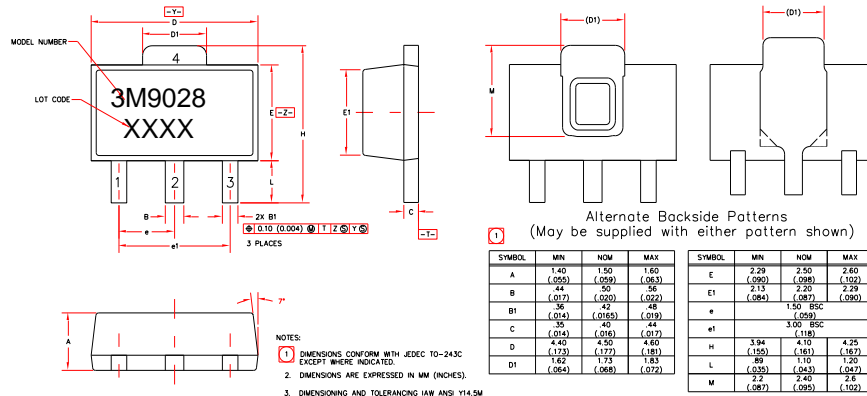

Notes:

1. All dimensions are in millimeters. Angles are in degrees.
2. Dimension and tolerance formats conform to ASME Y14.4M-1994.
3. The terminal #1 identifier and terminal numbering conform to JESD 95-1 SPP-012.

PCB Mounting Pattern

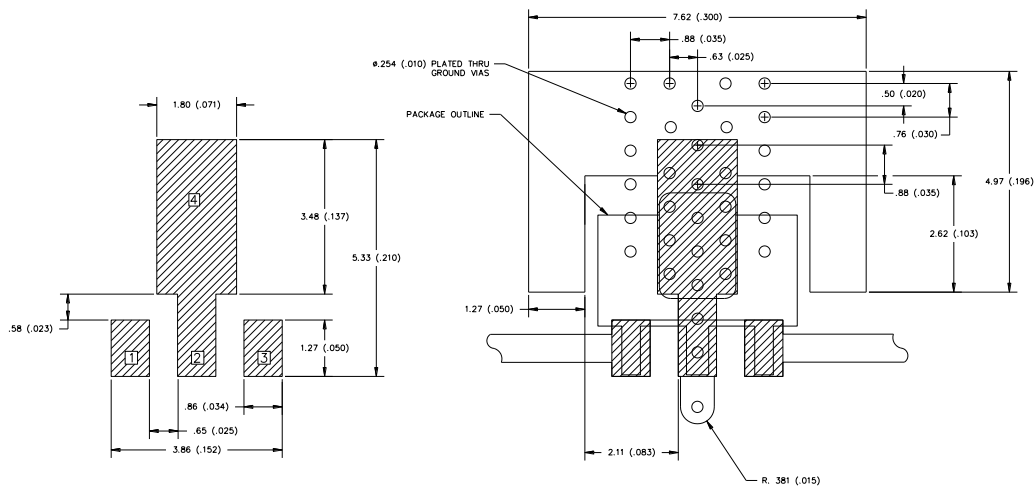

Notes:

1. All dimensions are in millimeters. Angles are in degrees.
2. Ground / thermal vias are critical for the proper performance of this device. Vias should use a .35mm (#80 / .0135") diameter drill and have a final plated thru diameter of .25 mm (.010").
3. Add as much copper as possible to inner and outer layers near the part to ensure optimal thermal performance.
4. RF trace width depends upon the PC board material and construction.
5. Use 1 oz. copper minimum for top and bottom layer metal.

Product Compliance Information

ESD Sensitivity Ratings



Caution! ESD-Sensitive Device

ESD Rating: Class 1A
Value: Passes ≥ 250 V to < 500 V
Test: Human Body Model (HBM)
Standard: JEDEC Standard JESD22-A114

ESD Rating: Class IV
Value: Passes ≥ 1000 V
Test: Charged Device Model (CDM)
Standard: JEDEC Standard JESD22-C101

MSL Rating

MSL Rating: Level 3
Test: 260°C convection reflow
Standard: JEDEC Standard IPC/JEDEC J-STD-020

Solderability

Compatible with both lead-free (260 °C max. reflow temperature) and tin/lead (245 °C max. reflow temperature) soldering processes.

Contact plating: NiPdAu

RoHs Compliance

This part is compliant with EU 2002/95/EC RoHS directive (Restrictions on the Use of Certain Hazardous Substances in Electrical and Electronic Equipment).

This product also has the following attributes:

- Lead Free
- Halogen Free (Chlorine, Bromine)
- Antimony Free
- TBBP-A ($C_{15}H_{12}Br_4O_2$) Free
- PFOS Free
- SVHC Free

Contact Information

For the latest specifications, additional product information, worldwide sales and distribution locations, and information about TriQuint:

Web: www.triquint.com
Email: info-sales@triquint.com

Tel: +1.503.615.9000
Fax: +1.503.615.8902

For technical questions and application information: Email: sjcapplications.engineering@triquint.com

Important Notice

The information contained herein is believed to be reliable. TriQuint makes no warranties regarding the information contained herein. TriQuint assumes no responsibility or liability whatsoever for any of the information contained herein. TriQuint assumes no responsibility or liability whatsoever for the use of the information contained herein. The information contained herein is provided "AS IS, WHERE IS" and with all faults, and the entire risk associated with such information is entirely with the user. All information contained herein is subject to change without notice. Customers should obtain and verify the latest relevant information before placing orders for TriQuint products. The information contained herein or any use of such information does not grant, explicitly or implicitly, to any party any patent rights, licenses, or any other intellectual property rights, whether with regard to such information itself or anything described by such information.

TriQuint products are not warranted or authorized for use as critical components in medical, life-saving, or life-sustaining applications, or other applications where a failure would reasonably be expected to cause severe personal injury or death.