

MultiConnect™ OCG-E

Open Communications Gateways - Embedded



The MultiConnect™ OCG-E embedded open communications gateways with CoreCDP™ comprise an open Linux development environment and a fully certified hardware offering that includes multiple interfaces (serial, USB, Ethernet and SD card) and internal peripherals (including a cellular modem and a GPS receiver) in one application-ready end user solution.

Applications that require device networking capability can now reside directly on select Multi-Tech gateways. By bringing together a cellular hardware development kit and Multi-Tech's CoreCDP, a distribution version of the Linux operating system and complete Linux build environment, you can create custom applications in a very short period of time. The MultiConnect OCG-E provides a flexible, quick and cost-effective way to bring your solution to market.

Hardware

- 400 MHz ARM9™ CPU
- 256MB NAND flash and 64MB SDRAM
- Carrier approved 2G or 3G cellular connectivity
- Non-cellular models available
- Optional dedicated GPS receiver
- 80-pin board-to-board connector
- Multiple interfaces available (serial, USB host and device, Ethernet and more)

CoreCDP™ Software

- Custom Linux distribution
- Provides complete Linux build environment
- Cross-compile thousands of open source software packages
- Create custom applications in a short period of time

Developer Kit

- Customized development board for use with all models
- Includes all physical interfaces, cables, power supply and antennas necessary to develop your application
- Speeds hardware and software development

Benefits

- Linux-based open source software
- Proven hardware for the development and deployment of custom applications
- Cost-effective alternative to custom manufacturing
- Comprehensive service and developer support

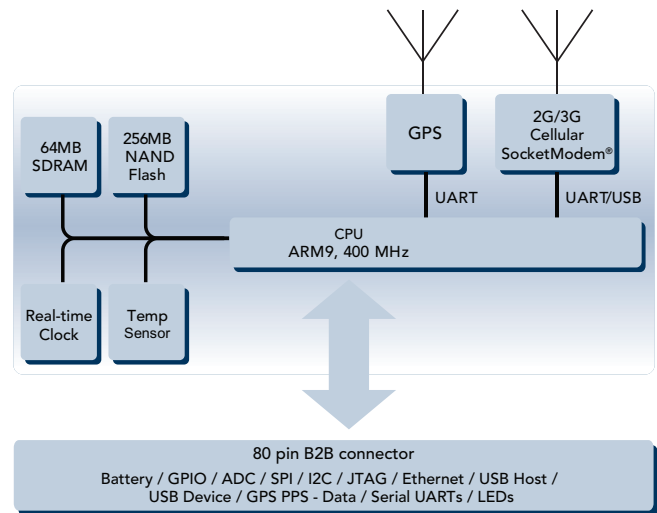

Support

- Advanced developer support available
- Established developer community available at www.multitech.net
- Two-year warranty

Highlights

Proven Hardware Platform. All MultiConnect OCG-E models are based on Multi-Tech's proven hardware design featuring our SocketModem® cellular communication devices and an ARM9 400MHz processor. The hardware is optimized for application development utilizing our CoreCDP Linux distribution.

Linux-Based Open Source. The MultiConnect OCG-E uses the OpenEmbedded framework as the base to provide a custom Linux distribution, known as CoreCDP. This allows developers to cross-compile thousands of open source software packages and to create custom applications in a very short period of time. In many cases, existing applications can easily be run with little or no modification.

Carrier Approved. All MultiConnect OCG-E models are carrier and PTCRB or CDG approved, relieving customers the burden and expense of obtaining these approvals independently. This also provides a faster time-to-market and improved return on investment.

Embedded OCG Pin-Out. The MultiConnect OCG-E interfaces to your design via an 80-pin board-to-board connector giving you full access and control of the numerous interfaces and peripherals. Local connectivity options include serial, USB device and host, Ethernet, SPI, I2C. In addition, there are several user definable GPIOs, ADCs and LEDs that can be utilized to enhance your products overall design. Also included are serial and JTAG debug ports to help speed application development and debug.

Developer's Kit. The Developer's Kit allows you to plug in the MultiConnect OCG-E communications device and use it for testing, programming and evaluation.

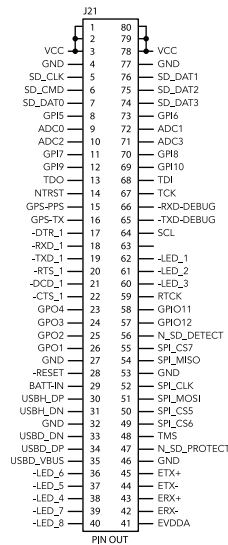

Comprehensive Service and Support

Standard Support. The Multi-Tech MultiConnect OCG-E includes a two-year product warranty on the hardware platform. This includes technical support, via the Multi-Tech online support portal, to assist with troubleshooting and basic hardware configurations.

Developer Community and Support. To support software developers who are using the MultiConnect OCG-E, Multi-Tech focuses on building better tools for collaborative software development using Multi-Tech products. This is an open environment where software developers can ask and respond to development-related questions regarding Multi-Tech products and access a variety of resources, including product documentation, application development examples, technical articles and much more.

You can also participate in developer forums on www.multitech.net to find and share ideas and tips. Moderated by Multi-Tech engineering professionals and the developer community, these forums address a wide variety of development topics to support your projects.

Advanced Developer Support. For developers needing dedicated support, Multi-Tech offers a fee-based support option available in 5-hour and 25-hour increments. Advanced Developer Support provides assistance with software issues, the porting of or cross-compiling of applications, use of peripherals and much more.

Hardware Specifications

Processor & Memory

- 400 MHz ARM9 CPU
- 256MB NAND flash
- 64MB SDRAM
- Developer kit includes an industrial grade 2GB SD flash memory card

Interfaces & Peripherals

- 1 x 10/100BaseT Autosensing Ethernet Interface
- 1 x Serial TTL Interface (DTR, RXD, TXD, RTS, DCD, CTS)
- 1 x Serial TTL Interface (Debug or Data, RXD, TXD)
- 1 x USB 2.0 Full Speed Device Interface
- 1 x USB 2.0 Full Speed Host Interface
- 1 x SPI Bus Interface (6-Pin)
- 1 x I2C Bus Interface (2-Pin)
- 1 x JTAG Debug Interface (6-Pin)
- 1 x SDIO Memory Card Interface (6-Pin)
- 4 x ADC Inputs
- 6 x General Purpose Inputs
- 4 x General Purpose Outputs
- 1 x Cellular Link Status LED Output
- 2 x Ethernet LED Outputs (Speed & Link)
- 1 x Status (Heartbeat)/User Definable LED Output
- 3 x Cellular Signal Strength/User Definable LED Outputs
- 1 x User Definable LED Output
- 6 x VCC DC Input Pins (5V)
- 6 x Logic Ground Pins
- Reset
- Battery Backup
- SD Card Detect
- SD Card Protect
- GPS PPS (Pulse Per Second)
- GPS Transmit Data
- RTC (Real Time Clock)
- Dedicated GPS receiver (Optional)
- 2G or 3G Cellular modem
- Temperature sensor

Hardware Specifications (continued)

Onboard LEDs

2G: Link status

Connections

80-Pin Board-to-Board

Manufacturer: Hirose

Part number: DF12 (3.0) -80DP-0.5V/86

Cellular Antenna: UFL

GPS Antenna: UFL

SIM: Standard 1.8/3V SIM receptacle (G2 & H4 models)

GPS

Position: 2.5 meters

Acquisition: Hot start 1 second; cold start 29 seconds avg.

Sensitivity: Tracking -161 dBm

Protocol: NMEA-0183 V3.01, GGA, GLL, GSA, GSV, RMC, VTG

CoreCDP Software Specifications

Linux Kernel 2.6.32.3

Utilizes OpenEmbedded framework

Tested with the following Linux OS:

Ubuntu 10.10 & 11.04

Fedora Core 12

OpenSUSE 12.1

Drivers to support all peripherals included on the platform hardware

Programming Languages: Python, Java (JamVM), Perl, Ruby, C/C++, PHP

Networking: PPP, iptables

Web Server: lighttpd

Remote shell: SSH

Database: sqlite3

Network file system: samba

Specifications	MT100EOCG-H4	MT100EOCG-EV2	MT100EOCG-G2
Performance	HSPA 7.2	EV-DO Rev A	GPRS Class 10
Frequency Bands	3G: 850/1900/2100 MHz 2G: 850/900/1800/1900 MHz	Dual-band 800/1900 MHz	Quad-band 850/900/1800/1900 MHz
Packet Data	HSDPA data up to 7.2 Mbps HSUPA data up to 5.76 Mbps	Peak download 3.1 Mbps Peak upload 1.8 Mbps	Up to 85.6K bps, coding schemes CS1 to CS4
Environmental			
Operating Temperature*	-22° to 185° F (-30° to +85° C)	-31° to 185° F (-35° to +85° C)	-31° to +185° F (-35° to +85° C)
Storage Temperature	-40° to +185° F (-40° to +85° C)		
Humidity	20% to 90% RH, noncondensing		
Power Requirements			
Input Power	5 VDC		
Power Draw	See Developers Guide	See Developers Guide	See Developers Guide
Certifications			
EMC Compliance	FCC Part 15 Class B, EN 55022, EN 55024	FCC Part 15 Class B	FCC Part 15 Class B, EN 55022, EN 55024
Radio Compliance	FCC Part 22, 24, RSS 132, 133, EN 301 489-1, EN 301 489-7, EN 301 489-24, EN 301 511	FCC Part 22, 24	FCC Part 22, 24, RSS 132, 133, EN 301 489-1, EN 301 489-7, EN 301 489-24, EN 301 511
Safety	UL 60950-1, cUL 60950-1, IEC 60950-1, A-Tick	UL 60950-1, cUL 60950-1, IEC 60950-1	UL 60950-1, cUL 60950-1, IEC 60950-1
Network	PTCRB, AT&T, Telus, Tegers, Telstra	CDG 1&2, Aeris, Sprint, Verizon	PTCRB, AT&T
Physical Description			
Length	3.650 inches (9.27 cm)		
Width	1.375 inches (3.49 cm)		
Max Component Height Top	.489 inches (1.24 cm)		
Max Component Height Bottom	.122 inches (.310 cm)		
Weight	1.7 oz (48 g)	1.7 oz (48 g)	1.4 oz (39 g)

* Extreme temperatures can impact the radio's performance; this is normal. The radio is designed to fallback in class to reduce transmitter power to avoid damaging the radio. See developers guide for additional information.

Specifications for the non-cellular models available in the developers guide.

Ordering Information

Cellular Only Models*

Product	Description	Region
MT100EOCG-H4-P1	3G, HSPA Open Communications Gateway (Generic†)	Regional
MT100EOCG-H4-P2	3G, HSPA Open Communications Gateway (AT&T)	USA
MT100EOCG-EV2-N2	3G, EV-DO Open Communications Gateway (Sprint)	USA
MT100EOCG-EV2-N3	3G, EV-DO Open Communications Gateway (Verizon)	USA
MT100EOCG-EV2-N16	3G, EV-DO Open Communications Gateway (Aeris)	USA
MT100EOCG-G2	2G, GPRS Open Communications Gateway	Global

Cellular & GPS Models*

Product	Description	Region
MT100EOCG-H4-GP-P1	3G, HSPA Open Communications Gateway w/GPS (Generic†)	Regional
MT100EOCG-H4-GP-P2	3G, HSPA Open Communications Gateway w/GPS (AT&T)	USA
MT100EOCG-EV2-GP-N2	3G, EV-DO Open Communications Gateway w/GPS (Sprint)	USA
MT100EOCG-EV2-GP-N3	3G, EV-DO Open Communications Gateway w/GPS (Verizon)	USA
MT100EOCG-EV2-GP-N16	3G, EV-DO Open Communications Gateway w/GPS (Aeris)	USA
MT100EOCG-GP-G2	2G, GPRS Open Communications Gateway w/GPS	Global

Non-cellular Models

Product	Description	Region
MT100EOCG	Open Communications Gateway	Global
MT100EOCG-GP	Open Communications Gateway w/GPS	Global

Developer Kit Model

Product	Description	Region
MT100EOCG-DK	Developer Kit for all Open Communications Gateway Models	Global

Developer Support

For developers needing dedicated support, Multi-Tech offers a fee-based support option. Advanced Developer Support provide assistance with software issues, the porting of or cross-compiling of applications, use of peripherals, and much more.

Product	Description	Region
CDPS-5	Developer Support - 5 hours	Global
CDPS-25	Developer Support - 25 hours	Global

* Product customization available. Contact your Multi-Tech Systems representative for details.

† Europe, Bell Mobility, Rogers, Telus and Telstra

Produced in the US of US and non-US components.

Features and specifications are subject to change without notice.

Trademarks / Registered Trademarks: MultiConnect, CoreCDP, SocketModem, Multi-Tech, and the Multi-Tech logo: Multi-Tech Systems, Inc. / All other products and technologies are the trademarks or registered trademarks of their respective holders.

World Headquarters

Tel: (763) 785-3500
(800) 328-9717

www.multitech.com

EMEA Headquarters

Multi-Tech Systems (EMEA)
United Kingdom

Tel: +(44) 118-959 7774