

TQP3M9007

1/4W High Linearity LNA Gain Block

Applications

- Repeaters
- Mobile Infrastructure
- LTE / WCDMA / CDMA / EDGE
- General Purpose Wireless

Product Features

- 100-4000 MHz
- 13 dB Gain @ 1.9 GHz
- 1.3 dB Noise Figure @ 1.9 GHz
- +41 dBm Output IP3
- +23.6 dBm P1dB
- 50 Ohm Cascadable Gain Block
- Unconditionally Stable
- High Input Power Capability
- +5V Single Supply, 125 mA Current
- SOT-89 Package

General Description

The TQP3M9007 is a high linearity low noise gain block amplifier in a low-cost surface-mount package. At 1.9 GHz, the amplifier typically provides 13 dB gain, +41 dBm OIP3, and 1.3 dB Noise Figure while drawing 125 mA current. The device is housed in a leadfree/green/RoHS-compliant industry-standard SOT-89 package.

The TQP3M9007 has the benefit of having high linearity while also providing very low noise across a broad range of frequencies. This allows the device to be used in both receive and transmit chains for high performance systems. The amplifier is internally matched using a high performance E-pHEMT process and only requires an external RF choke and blocking/bypass capacitors for operation from a single +5V supply. The internal active bias circuit also enables stable operation over bias and temperature variations.

The TQP3M9007 covers the 0.1 - 4 GHz frequency band and is targeted for wireless infrastructure or other applications requiring high linearity and/or low noise figure.



SOT-89 Package

Functional Block Diagram

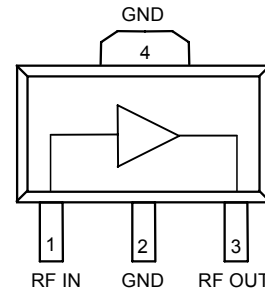

Pin Configuration

Pin #	Symbol
1	RF IN
3	RF OUT
2, 4	GND

Ordering Information

Part No.	Description
TQP3M9007	High Linearity LNA Gain Block
TQP3M9007-PCB	0.5-4 GHz Evaluation Board

Standard T/R size = 1000 pieces on a 7" reel.

TQP3M9007

¼W High Linearity LNA Gain Block

Specifications

Absolute Maximum Ratings

Parameter	Rating
Storage Temperature	-55 to 150 °C
RF Input Power, CW, 50 Ω, T=25°C	+20 dBm
Device Voltage, V _{dd}	+7 V

Operation of this device outside the parameter ranges given above may cause permanent damage.

Recommended Operating Conditions

Parameter	Min	Typ	Max	Units
V _{dd}	3	5	5.25	V
T _{case}	-40		+85	°C
T _j (for >10 ⁶ hours MTTF)			190	°C

Electrical specifications are measured at specified test conditions. Specifications are not guaranteed over all recommended operating conditions.

Electrical Specifications

Test conditions unless otherwise noted: +25°C, +5V supply, 50 Ω system.

Parameter	Conditions	Min	Typical	Max	Units
Operational Frequency Range		100		4000	MHz
Test Frequency			1900		MHz
Gain		11.5	13	14.5	dB
Input Return Loss			18		dB
Output Return Loss			13		dB
Output P1dB			+23.6		dBm
Output IP3	See Note 1.	+37	+41		dBm
Noise Figure			1.3		dB
Supply Voltage, V _{dd}			+5		V
Current, I _{dd}			125	150	mA
Thermal Resistance (jnc to case) θ _{jc}			52		°C/W

Notes:

1. OIP3 is measured with two tones at an output power of 4 dBm / tone separated by 1 MHz. The suppression on the largest IM3 product is used to calculate the OIP3 using 2:1 rule. 2:1 rule gives relative value with respect to fundamental tone.

TQP3M9007

¼W High Linearity LNA Gain Block



Device Characterization Data

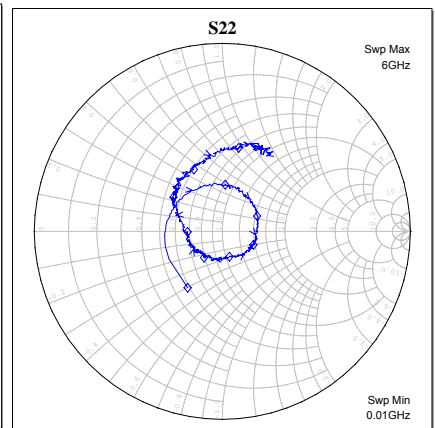
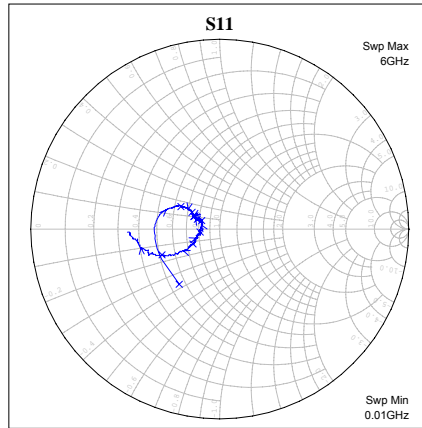
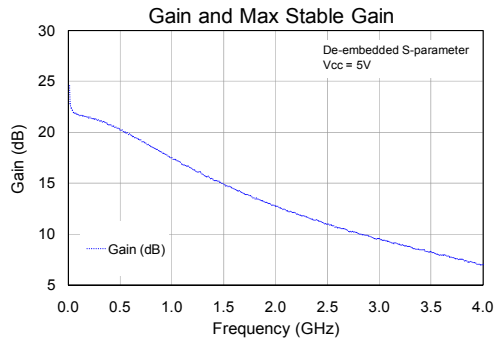

S-Parameter Data

$V_{dd} = +5\text{ V}$, $I_{cq} = 125\text{ mA}$, $T = +25^{\circ}\text{C}$, unmatched 50 ohm system, calibrated to device leads

Freq (MHz)	S11 (dB)	S11 (ang)	S21 (dB)	S21 (ang)	S12 (dB)	S12 (ang)	S22 (dB)	S22 (ang)
50	-9.21	-171.69	21.92	165.87	-28.66	7.52	-10.26	-177.68
100	-9.18	178.66	21.72	164.31	-28.54	8.08	-10.62	166.81
200	-9.58	168.58	21.39	154.89	-28.25	11.48	-10.93	145.14
400	-11.09	155.91	20.71	134.86	-27.05	16.59	-11.61	112.74
800	-13.55	148.37	18.58	99.19	-24.58	17.74	-12.39	63.78
1000	-14.69	147.37	17.47	84.06	-23.58	14.87	-13.43	40.99
1200	-15.31	148.14	16.33	70.48	-22.59	12.31	-13.72	23.70
1500	-16.32	152.38	14.85	52.18	-21.45	6.08	-14.84	-3.77
1900	-16.36	155.45	13.11	30.26	-19.96	-2.85	-15.21	-32.08
2000	-16.44	154.43	12.73	25.52	-19.77	-5.72	-15.43	-42.20
2200	-16.55	154.33	11.98	15.20	-19.13	-12.30	-16.18	-54.41
2500	-16.78	153.75	10.97	0.51	-18.24	-20.16	-16.76	-84.02
2600	-16.83	154.69	10.59	-4.70	-18.14	-23.60	-16.24	-91.43
3000	-17.62	157.51	9.53	-24.26	-17.17	-36.43	-16.21	-128.42
3500	-18.79	154.34	8.24	-48.07	-16.19	-53.90	-14.74	-165.72
4000	-20.11	176.37	7.01	-72.56	-15.53	-72.99	-11.54	154.74

TQP3M9007

¼W High Linearity LNA Gain Block

Application Circuit Configuration

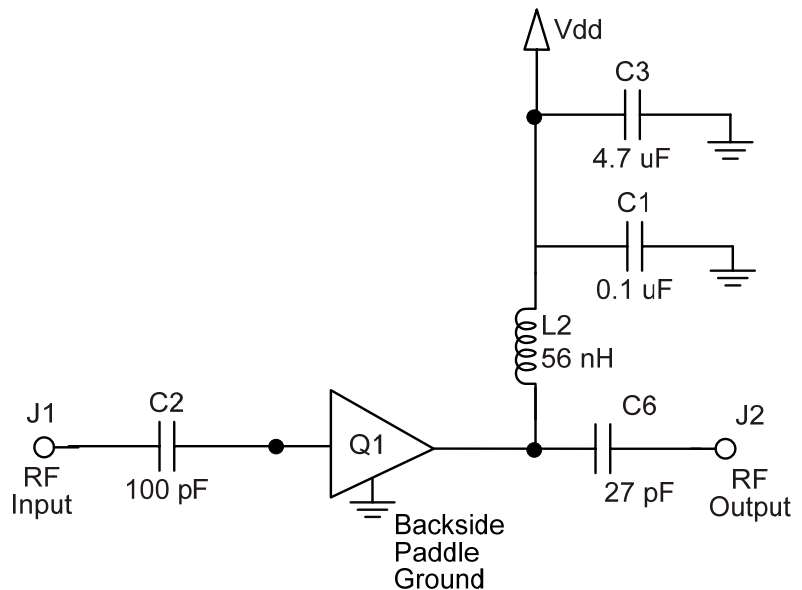
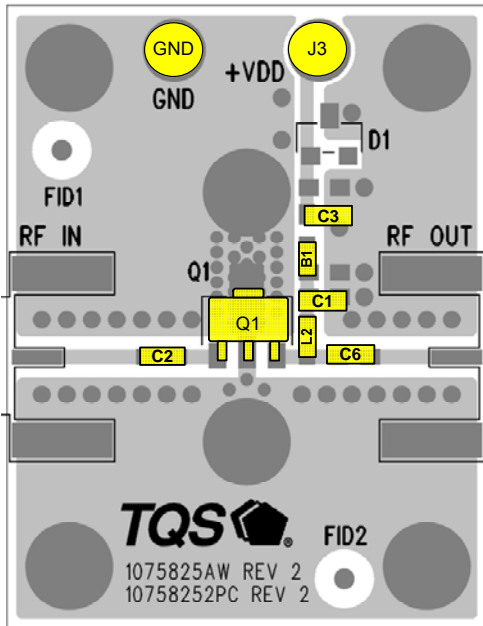

Notes:

1. See PC Board Layout, under Application Information section, for more information.
2. Components shown on the silkscreen but not on the schematic are not used.
3. B1 (0 Ω jumper) may be replaced with copper trace in the target application layout.
4. All components are of 0603 size unless stated on the schematic.
5. C6 and L2 value are critical for linearity performance.

Bill of Material: TQP3M9007-PCB

Reference Desg.	Value	Description	Manufacturer	Part Number
Q1		High Linearity LNA Gain Block	TriQuint	TQP3M9007
C2	100 pF	Cap, Chip, 0603, 50V, NPO, 5%	various	
C6	27 pF	Cap, Chip, 0603, 50V, NPO, 5%	various	
C1	0.1 uF	Cap, Chip, 0603, 16V, X7R, 10%	various	
L2	56 nH	Ind, Chip, 0603, 5%	various	
C3	4.7 uF	Cap, Chip, 0603, 6.3V, X5R, 20%	various	
B1	0 Ω	Res, Chip, 0603, 1/16W, 5%	various	
D1	Do Not Place		various	

TQP3M9007

1/4W High Linearity LNA Gain Block



Typical Performance TQP3M9007-PCB

Test conditions unless otherwise noted: +25°C, +5V, 125 mA, 50 Ω system. The data shown below is measured on TQP3M9007-PCB

Frequency	MHz	500	900	1900	2100	2600
Gain	dB	20	18	13	12	10
Input Return Loss	dB	11.5	14	18	17.5	15.5
Output Return Loss	dB	10.5	13	13	12	10.5
Output P1dB	dBm	+22.9	+23.3	+23.5	+23.8	+24.0
OIP3 [1]	dBm	+39.3	+40.2	+41.1	+42.2	+42.2
Noise Figure [2]	dB	1.4	1.2	1.3	1.4	1.8

Notes:

- OIP3 measured with two tones at an output power of +4 dBm / tone separated by 1 MHz. The suppression on the largest IM3 product is used to calculate the OIP3 using 2:1 rule.
- Noise figure data shown in the table above is measured on evaluation board and corrected for the board loss of about 0.13 dB @ 1.9 GHz.

Performance Plots

Performance plots data is measured using TQP3M9007-PCB. Noise figure plot has been corrected for evaluation board loss of 0.13 dB @ 1.9 GHz.

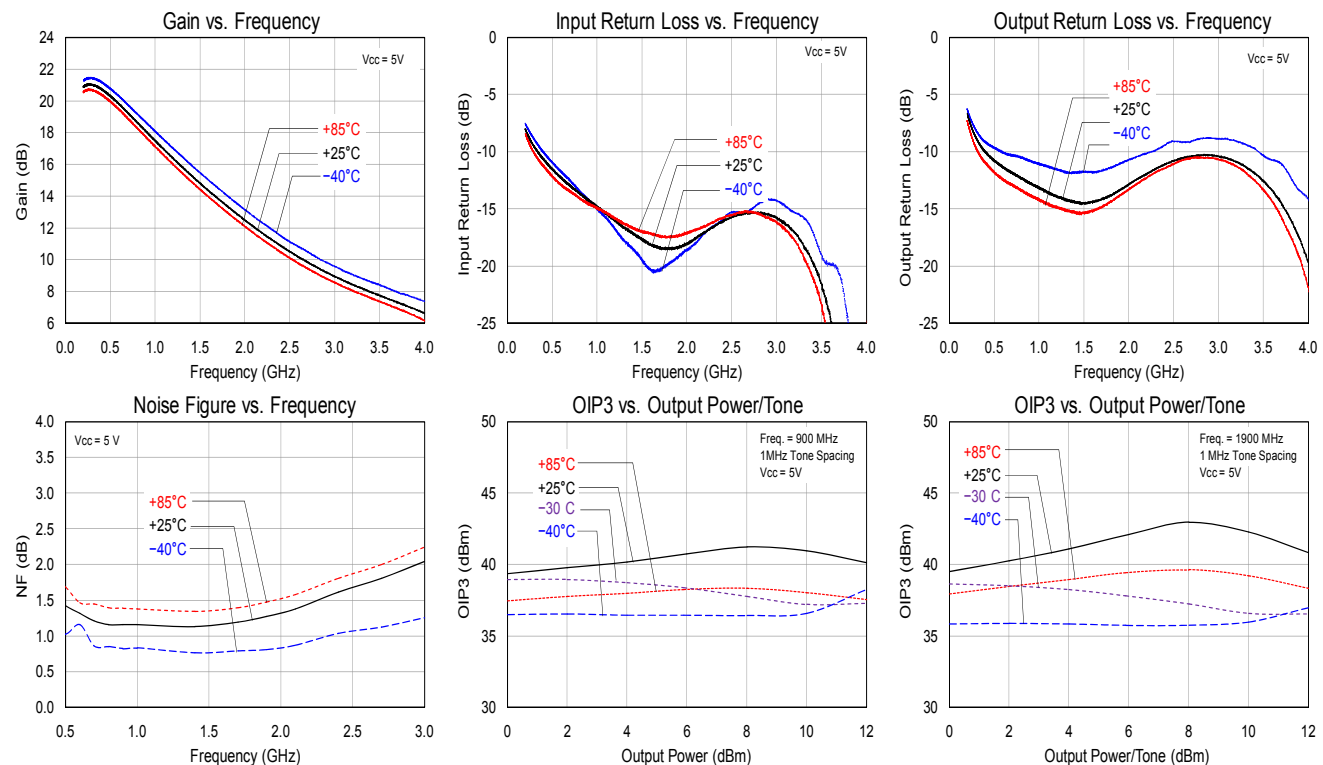

TQP3M9007

1/4W High Linearity LNA Gain Block

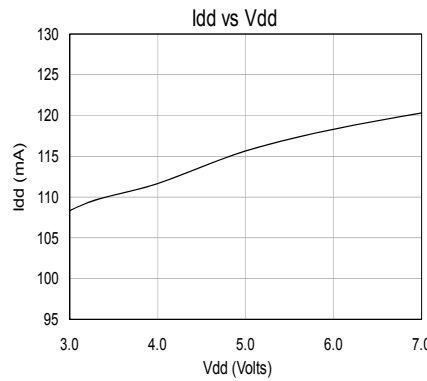
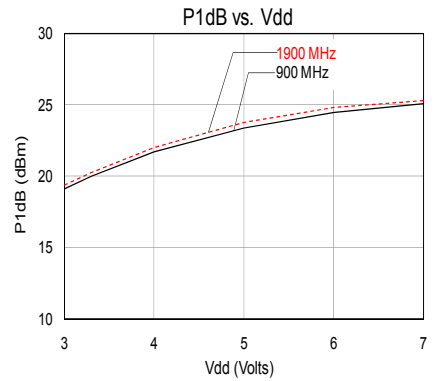
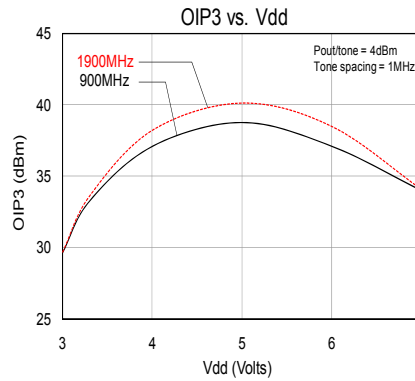
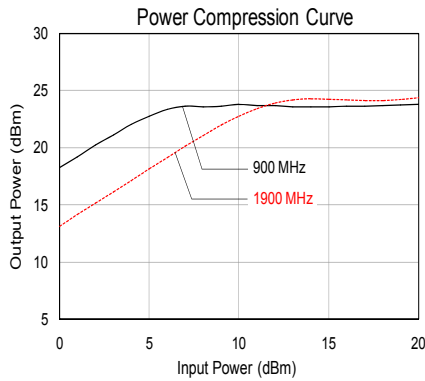
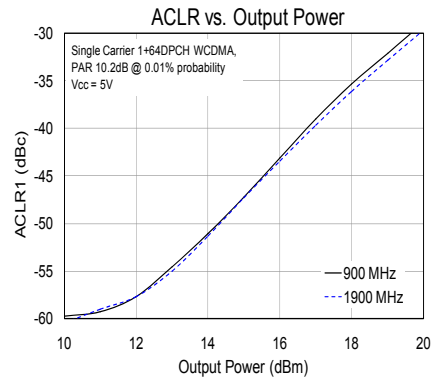
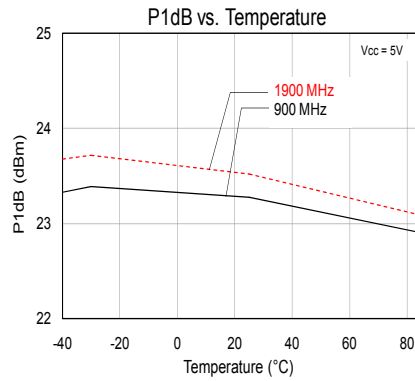
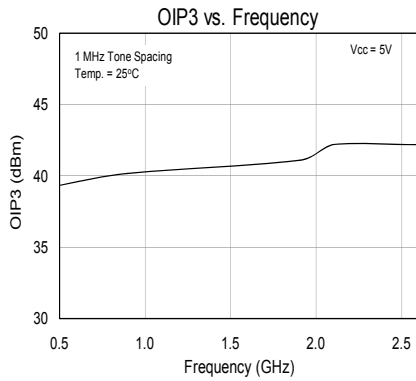

TQP3M9007

1/4W High Linearity LNA Gain Block

Pin Description

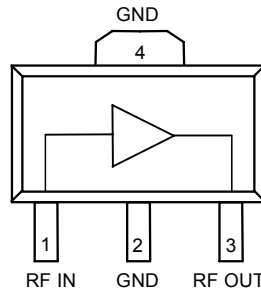

Pin	Symbol	Description
1	RF Input	Input, matched to 50 ohms. External DC Block is required.
3	V _{dd} / RFout	Output, matched to 50 ohms, External DC Block is required and supply voltage.
2, 4	GND Paddle	Backside Paddle. Multiple vias should be employed to minimize inductance and thermal resistance; see page 7 for mounting configuration.

Applications Information

PC Board Layout

Top RF layer is .014" NELCO N4000-13, $\epsilon_r = 3.9$, 4 total layers (0.062" thick) for mechanical rigidity. Metal layers are 1-oz copper. 50 ohm Microstrip line details: width = .029", spacing = .035"

The pad pattern shown has been developed and tested for optimized assembly at TriQuint Semiconductor. The PCB land pattern has been developed to accommodate lead and package tolerances. Since surface mount processes vary from company to company, careful process development is recommended.

For further technical information, Refer to www.TriQuint.com

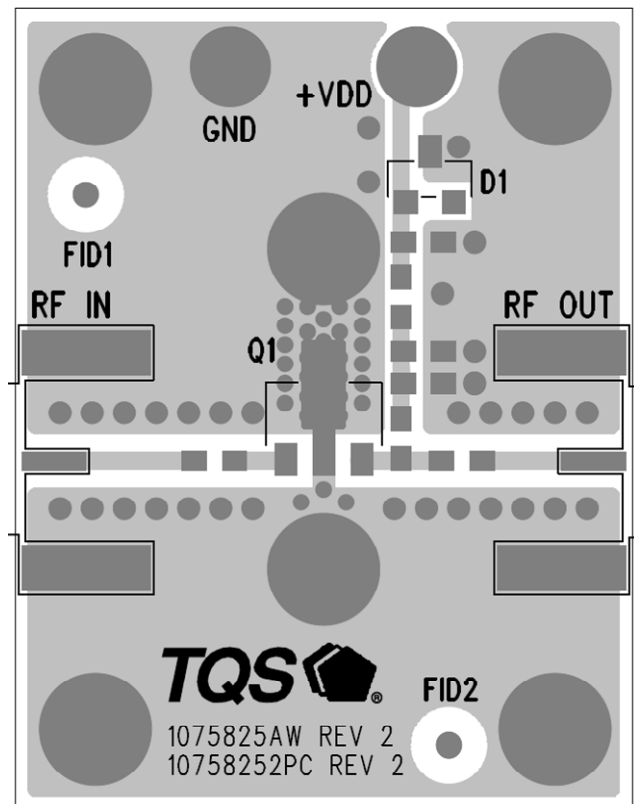

TQP3M9007

1/4W High Linearity LNA Gain Block



Mechanical Information

Package Information and Dimensions

Markings:

Part number: 3M9007

Assembly code: 'Y' is last digit of part manufacture year. 'XXX' is lot code.

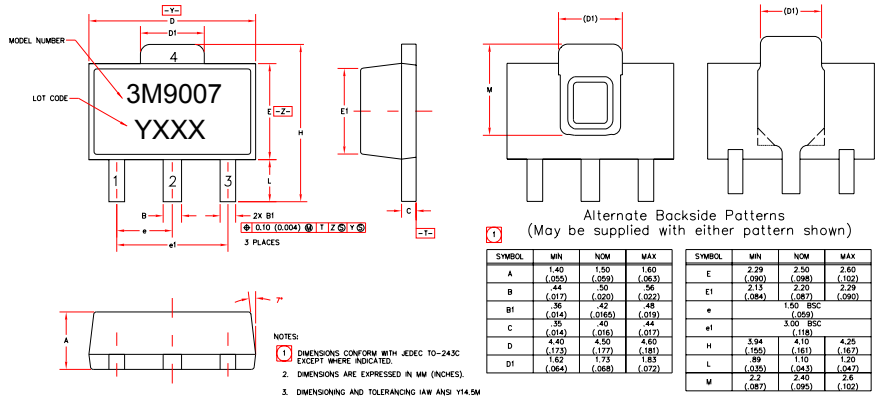

PCB Mounting Pattern

All dimensions are in millimeters (inches). Angles are in degrees.

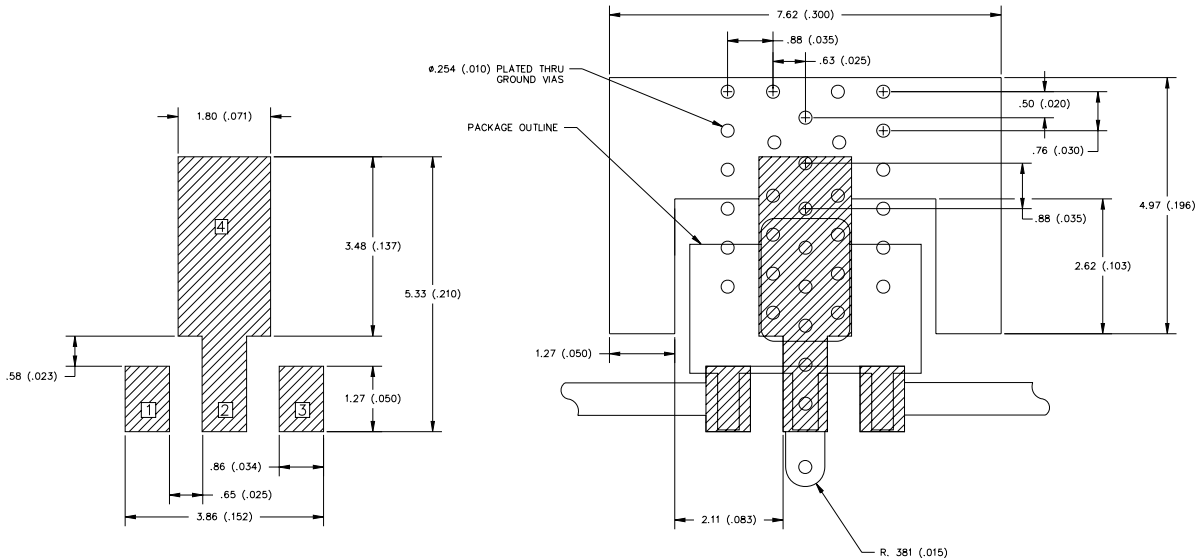

Notes:

1. Ground / thermal vias are critical for the proper performance of this device. Vias should use a .35mm (#80 / .0135") diameter drill and have a final plated thru diameter of .25 mm (.010").
2. Add as much copper as possible to inner and outer layers near the part to ensure optimal thermal performance.
3. RF trace width depends upon the PC board material and construction.
4. Use 1 oz. Copper minimum.

TQP3M9007

¼W High Linearity LNA Gain Block

Product Compliance Information

ESD Information



Caution! ESD-Sensitive Device

ESD Rating: Class 1A
Value: Passes ≥ 250 V to < 500 V
Test: Human Body Model (HBM)
Standard: JEDEC Standard JESD22-A114

ESD Rating: Class IV
Value: Passes ≥ 1000 V
Test: Charged Device Model (CDM)
Standard: JEDEC Standard JESD22-C101

MSL Rating

Moisture Sensitivity Level 3 at 260°C per JEDEC standard IPC/JEDEC J-STD-020.

Solderability

Compatible with both lead-free (maximum 260°C reflow temperature) and lead (maximum 245°C reflow temperature) soldering processes.

This part is compliant with EU 2002/95/EC RoHS directive (Restrictions on the Use of Certain Hazardous Substances in Electrical and Electronic Equipment).

This product also has the following attributes:

- Lead Free
- Halogen Free (Chlorine, Bromine)
- Antimony Free
- TBBP-A ($C_{15}H_{12}Br_4O_2$) Free
- PFOS Free
- SVHC Free

Contact Information

For the latest specifications, additional product information, worldwide sales and distribution locations, and information about TriQuint:

Web: www.triquint.com
Email: info-sales@tqs.com

Tel: +1.503.615.9000
Fax: +1.503.615.8902

For technical questions and application information:

Email: sicapplications.engineering@tqs.com

Important Notice

The information contained herein is believed to be reliable. TriQuint makes no warranties regarding the information contained herein. TriQuint assumes no responsibility or liability whatsoever for any of the information contained herein. TriQuint assumes no responsibility or liability whatsoever for the use of the information contained herein. The information contained herein is provided "AS IS, WHERE IS" and with all faults, and the entire risk associated with such information is entirely with the user. All information contained herein is subject to change without notice. Customers should obtain and verify the latest relevant information before placing orders for TriQuint products. The information contained herein or any use of such information does not grant, explicitly or implicitly, to any party any patent rights, licenses, or any other intellectual property rights, whether with regard to such information itself or anything described by such information. TriQuint products are not warranted or authorized for use as critical components in medical, life-saving, or life-sustaining applications, or other applications where a failure would reasonably be expected to cause severe personal injury or death.