



**TRM-915-DTS /
TRM-915-DTS-BRZ**

**Data Guide
(Preliminary)**

Wireless made simple®

Table of Contents

1	Introduction
2	Features
2	Applications
2	Electrical Specifications
2	Absolute Maximum Ratings
4	Detailed Electrical Specifications
7	Module Overview
7	Theory of Operation
7	General
12	Operating States
13	Resetting Module to Factory Defaults
13	Hardware Reset
14	Application Information
14	Pin-out Diagram
14	Pin Description
15	Mechanical Drawings
16	Example Circuit
17	Power Supply
18	UART Interface
18	Antenna
19	Link Budget, Transmit Power and Range Performance
21	Module Configuration
21	Channel Settings
22	Power Mode
24	UART Data Rate
25	Network Mode
25	Transmit Wait Timeout
26	Network Group
26	CRC Control
26	UART Minimum Transmission Unit
27	Verbose Mode

27	CSMA Enable
27	Sleep Control
28	ACK on Wake
28	MAC Address
29	Release Number
30	Register Summary
32	Using Configuration Registers
32	CMD Pin
32	Command Formatting
34	Writing to Registers
35	Reading from Registers
38	Custom Applications
38	Ordering Information

TRM-915-DTS / TRM-915-DTS-BRZ Data Guide (Preliminary)



Introduction

The TRM-915-DTS module and TRM-915-DTS-BRZ variant (collectively referred to as the DTS Series) combine a state-of-the-art low power wireless transceiver with a powerful multipoint-to-multipoint protocol controller to form a transparent wireless communication solution capable of replacing wires in almost any RS-232/422/485 application. With a 115dB link budget and very low power operation modes, the DTS Series is excellent for AMR, RFID, Home Automation, and any other application requiring long range (1 mile line of sight) and long battery life.



Figure 1: TRM-915-DTS Module

Features

- True UART to antenna solution
- 16-bit CRC error checking
- 100kbps maximum RF data rate
- 32 channels in DTS mode, 84 channels in LP mode, North American version
- 19 unique channels in DTS mode, 52 unique channels in LP mode, Brazilian version
- Small size – 0.8" x 0.935" .08"
- Low power Standby and Sleep modes
- PHY and MAC layer protocol built in
- CSMA medium access control
- 115dB link budget in DTS mode
- 4 modes allow user to optimize power/range
- Command mode for volatile and non-volatile configuration
- 48-bit unique address
- 5 volt tolerant I/O
- 868–870MHz European version available

Applications

- Direct RS-232/422/485 Wire replacement (requires external RS-232 to 3V CMOS conversion circuitry)
- Asset tracking
- Automated meter reading
- Industrial and/or home automation
- RFID
- Wireless sensors
- Remote data logging
- Fleet management

Electrical Specifications

Absolute Maximum Ratings

Operating the module in conditions that exceed the absolute maximum ratings may cause damage to the device. Operation at these ratings is not implied. Exposure to maximum rating conditions for an extended period of time may adversely affect device reliability.

Absolute Maximum Ratings			
Parameter	Min.	Max.	Units
Vdd – Power Supply		3.9	VDC
Voltage on any I/O pin	-0.3	5.3	VDC
Allowed Vdd Rise Time		1	ms
Input RF level		-1	dBm
Storage Temperature	-40	+85	°C

Figure 1: Absolute Maximum Ratings

Warning: Linx radio frequency (“RF”) products may be used to control machinery or devices remotely, including machinery or devices that can cause death, bodily injuries, and/or property damage if improperly or inadvertently triggered, particularly in industrial settings or other applications implicating life-safety concerns. No Linx Technologies product is intended for use in any application without redundancies where the safety of life or property is at risk.

The customers and users of devices and machinery controlled with RF products must understand and must use all appropriate safety procedures in connection with the devices, including without limitation, using appropriate safety procedures to prevent inadvertent triggering by the user of the device and using appropriate security codes to prevent triggering of the remote controlled machine or device by users of other remote controllers.

All RF products are susceptible to RF interface that can prevent communication.

Do not use any Linx product over the limits in this data guide. Excessive voltage or extended operation at the maximum voltage could cause product failure. Exceeding the reflow temperature profile could cause product failure which is not immediately evident.

Do not make any physical or electrical modifications to any Linx product. This will void the warranty and regulatory and UL certifications and may cause product failure which is not immediately evident.

Detailed Electrical Specifications

AC Specifications – RX					
Parameter	Min.	Typ.	Max.	Units	Notes
Receiver Frequency	902.2		927.8	MHz	At antenna pin
Channels: DTS Mode		32			
Channels: LP Mode		84			
Channel Spacing: DTS Mode		750		kHz	
Channel Spacing: LP Mode		300		kHz	
Receiver Sensitivity: DTS Mode		-100		dBm	152.34kbps RF
Receiver Sensitivity: DTS Mode		-102		dBm	38.4kbps RF
Receiver Sensitivity: DTS Mode		-104		dBm	9.6kbps RF
Receiver Sensitivity: LP Mode		-104		dBm	38.4kbps RF
Receiver Sensitivity: LP Mode		-105		dBm	9.6kbps RF
Input IP3		-40		dBm	$F_{LO}+1\text{MHz}$ and $F_{LO}+1.945\text{MHz}$
Input Impedance		50		Ohms	No matching required
LO Leakage		-65		dBm	50ohm termination at ANT
Adjacent Channel Rejection		-48		dBc	$F_c \pm 650\text{kHz}$
IF Bandwidth: DTS Mode		600		kHz	
IF Bandwidth: LP Mode		200		kHz	

Figure 2: AC Specifications – RX

AC Specifications – TX					
Parameter	Min.	Typ.	Max.	Units	Notes
Transmit Frequency	902.2		927.8	MHz	
Maximum Effective RF Data Rate		100		kbps	Encoding/over-head losses included, 144 byte MTU
Center Frequency Error		2	5	ppm	915MHz at 25°C
Frequency Deviation: DTS Mode		235		kHz	
Frequency Deviation: LP Mode		75		kHz	
Low Output Power, Conducted		-4	-1	dBm	915MHz into 50ohm load
Mid-Low Output Power, Conducted		1	4	dBm	915MHz into 50ohm load
Mid-High Output Power, Conducted		11	14	dBm	915MHz into 50ohm load
Output Impedance		50		ohms	915MHz into 50ohm load
Carrier Phase Noise		TBD		dBc	Into 50ohm load
Harmonic Output		-50		dBc	Into 50ohm load

Figure 3: AC Specifications – TX

DC Specifications					
Parameter	Min.	Typ.	Max.	Units	Notes
Operating Temperature	-40		+85	°C	HW Revision C and later
Supply Voltage	2.7	3.3	3.6	VDC	
Receive Current Consumption		16-24		mA	Continuous operation, C _{dd} = 3.3VDC, varies with UART data rate selected
Transmit Current Consumption					
Low Power		26-35		mA	Output into 50-ohm load, V _{dd} =3.3VDC, depends on data rate selected
Mid-Low Power		33-44		mA	
Mid-High Power		48-56		mA	
High Power		63-72		mA	
Standby Current Consumption		850		µA	V _{dd} = 3.3VDC
Sleep Current Consumption		35		µA	V _{dd} = 3.3VDC
V _{Ih} : Logic High Level Input	0.7*V _{cc}		5.0	VDC	
V _{Il} : Logic Low Level Input	0		0.3*V _{cc}	VDC	
V _{Oh} : Logic High Level Output	2.5		V _{cc}	VDC	
V _{Ol} : Logic Low Level Output	0		0.4	VDC	

Figure 4: DC Specifications

Flash Specifications (Non-Volatile Registers)					
Parameter	Min.	Typ.	Max.	Units	Notes
Flash Write Duration		16	21	ms	Module stalled during write operation
Flash Write Cycles	20k	100k		cycles	

Figure 5: Flash Specifications (Non-Volatile Registers)

Module Overview

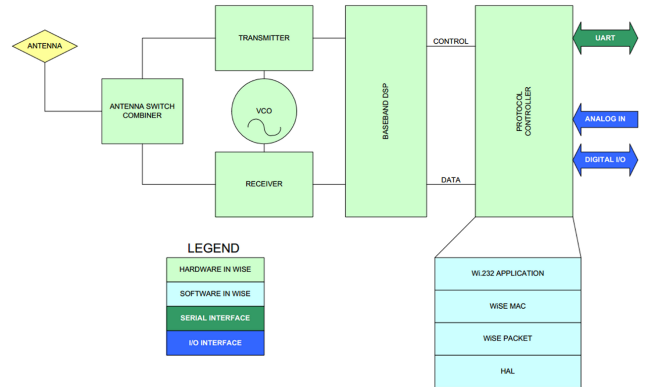

Figure 6: Module Overview

Theory of Operation

General

The DTS Series module is one of a family of WISE™ (Wireless Serial Engine) modules. A WISE™ module combines a state-of-the-art DTS/FSK data transceiver and a high-performance protocol controller to create a complete embedded wireless communications link in a tiny IC-style package.

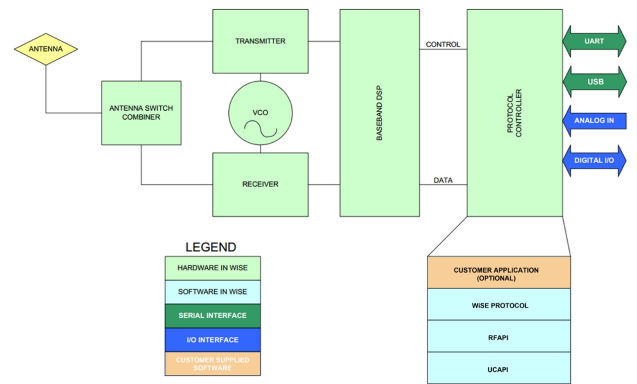

Figure 7: WISE Block Diagram

The module has a UART-type serial interface and contains special application software to create a transparent UART-to-antenna wireless solution capable of direct wire replacement in most embedded RS-232/422/485 applications.

Note: Although the module is capable of supporting the typical serial communications required by RS-232, RS-422, and RS-485 networks, it is not compatible with the electrical interfaces for these types of networks. The module has CMOS inputs and outputs and would require an appropriate converter for the particular type of network it is connected to.

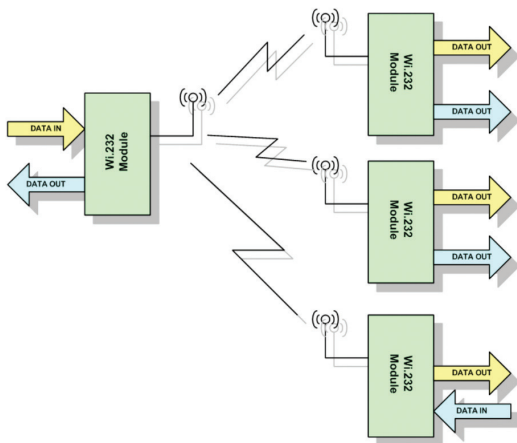

Figure 8: Wi.232DTS Networking Concept

The module is designed to interface directly to a host UART. Three signals are used to transfer data between the module and the host UART: **TXD**, **RXD** and **CTS**. **TXD** is the data output from the module. **RXD** is the data input to the module. **CTS** data output indicates the status of the module's data interface. If **CTS** is low, the module is ready to accept data. If **CTS** is high, the module is busy and the host UART should not send any further data.

Internally, the module has a 192 byte buffer for incoming characters from the host UART. The module can be programmed to automatically transmit

when the buffer reaches a programmed limit, set by **regUARTMTU**. The module can also be programmed to transmit based on a delay between characters, set by **regTXTO** (set in 1mSec increments). These registers allow the designer to optimize performance of the module for fixed length and variable length data. The module will support streaming data, as well. To optimize the module for streaming data, **regUARTMTU** should be set to 144, and **regTXTO** should be set to a value greater than 1 byte time at the current UART data rate. If the buffer gets full, or the timer set by **regTXTO** expires, while the module is still in the process of sending the previous packet over the RF link, the module will assert **CTS** high, indicating that the host should not send any more data. Data sent by the host while **CTS** is high will be lost.

When the MAC layer has a packet to send, it will use a **carrier-sense-multiple-access (CSMA)** protocol to determine if another module is already transmitting. If another module is transmitting, the module will receive that data before attempting to transmit its data again. If, during this process, the UART receive buffer gets full, the **CTS** line will go high to prevent the host UART from over-running the receive buffer. The CSMA mechanism introduces a variable delay to the transmission channel. This delay is the sum of a random period and a weighted period that is dependent on the number of times that the module has tried and failed to acquire the channel. For applications that guarantee that only one module will be transmitting at any given time, the CSMA mechanism can be turned off to avoid this delay.

The MAC layer prefixes the data with a packet header and postfixes the data with a 16-bit CRC. The 16-bit CRC error checking can be disabled to allow the application to do its own error checking. Data is encoded using a proprietary algorithm (DirectSPREAD™) to spread the RF energy within the transmission bandwidth.

Modules can operate in groups. Each module can be assigned an 8-bit group ID, which is used to logically link it to other modules on the same channel. All modules on a channel will interoperate, regardless of their respective group IDs. In other words, the CSMA mechanism will prevent collisions of modules on the same channel but belonging to different groups.

Modules can also operate in two network modes: Master/Slave and Peer-to-Peer. These modes define a set of communication rules that identifies which modules can talk to any given module. In Master/Slave mode, masters can talk to slaves and other masters, slaves can talk to masters, but slaves cannot talk to other slaves. This mode is sometimes required

for applications that are replacing legacy RS-485 networks. In peer-to-peer mode, any module can hear any other module. In both modes, group integrity is enforced.

When a module transmits a packet, all other modules on the same channel will receive the packet, check the packet for errors, and determine whether the received group ID matches the local group ID. If the packet is error free and the group IDs match, the module will decrypt the data if necessary, and send the error free data to its host UART for processing. The modules only implement the ISO reference network stack up to the MAC layer, so they are transparent to link layer addressing schemes. Therefore, the modules can work with any link-layer and higher protocols in existence today.

Certain features of the module are controlled through programmable registers. Registers are accessed by bringing **CMD** low. When **CMD** is low, all data transfers from the host UART are considered to be register access commands. When **CMD** is high, all data transfers from the host UART are considered to be raw data that needs to be transparently transmitted across the wireless link. The module maintains two copies of each register: one in flash and one in RAM. On reset, the module loads the RAM registers from the values in the flash registers. The module is operated out of the RAM registers. Applications that need to change parameters of the module often would simply modify the RAM registers. Putting default settings in the flash registers ensures the module always comes up in a preconfigured state, which is useful for applications that do not have external microcontrollers, such as RS-232 adapters.

The UART interface is capable of operating in full duplex at baud rates from 2.4 to 115.2kbps.

The module has ten power modes: High LP, Mid-High LP, Mid-Low LP, Low DTS, High DTS, Mid-High DTS, Mid-Low DTS, Low LP, Standby, and Sleep.

The DTS Series is the first module in the world to take advantage of the DTS digital spread spectrum provision in FCC part 15 rules. Under this provision, transmitters can operate at a higher output power if the transmission bandwidth is at least 500kHz. Through an encoding technique we call DirectSPREAD™, the outgoing RF data is encoded with symbols selected to ensure its average duty cycle is 50%. This allows the

module to be able to operate at +11dBm and meet the requirements of this provision.

In DTS mode, the module's channel bandwidth is set to 600kHz and the transmit power is set to one of four selectable levels. In this mode, the module can operate on 32 channels and support a maximum effective RF data rate of 100kbps. The receiver sensitivity at the max data rate is -100dBm typical, yielding a link budget of 111dB. This mode is an excellent alternative to Frequency Hopping Spread Spectrum. It has no synchronization requirements, allowing it to operate in a duty-cycle mode for extended battery life.

In low-power (LP) mode, the module's channel bandwidth is set to 200kHz and the transmit power is set to one of four selectable levels. In this mode, the module can operate on 84 channels and support a maximum data rate of 19.2kbps. The receiver sensitivity at the maximum data rate is -105dBm typical, yielding a link budget of 102dB. This mode reduces transmit current consumption, allowing use with batteries that cannot supply the pulse currents required for DTS mode. The range in this mode will be a little more than half of the range in DTS mode. Power settings other than low are available in LP mode, but should only be used when the antenna circuit is lossy.

Note: When in sleep mode, the module will not be able to receive data from other modules. Any data sent to the module while it is in sleep mode will be lost.

If the current draw in sleep mode is too high for a particular application, the designer can switch power to the module through a FET to "turn-off" the module when it is not needed. If this technique is used, the volatile registers will reset to the values in their non-volatile mirrors, so any changes from the default will have to be reloaded.

The DTS Series is a very flexible module because of all of the configurable parameters it supports. However, modules that are not configured in the same way will not be able to communicate reliably, causing poor performance or outright failure of the wireless link. **All modules in a network must have the same mode configuration to ensure interoperability.**

Every module has read-only internal registers that contain factory programmed information that includes calibration data and a 48-bit

MAC address that can be used by the host application for higher level, connection oriented protocols. This MAC address can be read through the command interface.

Operating States

The primary active state is the IDLE state. When the module is not actively transmitting or receiving data, it is in this state. While in this state, the receiver is enabled and the module is continuously listening for incoming data. If the module detects a pre-amble and valid start-code, it will enter the RX_HEADER state.

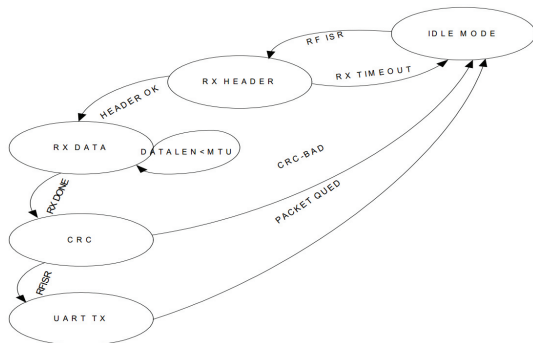

Figure 9: RX State Machine

If the module is in the IDLE state and a byte is received by the UART, it will enter the TX_WAIT state.

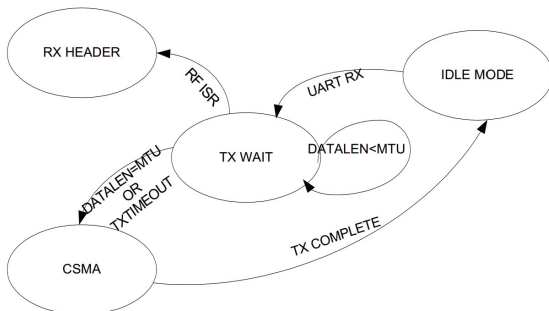

Figure 10: TX State Machine

Resetting Module to Factory Defaults

It may be necessary to reset the non-volatile registers to their factory defaults. To reset the module to factory defaults, hold the command line low and cycle power to or hardware-reset the module. The command line must remain low for a minimum of 450ms after resetting the module. Once the command line is released, the module's non-volatile registers will be reset to factory defaults.

Hardware Reset

By pulling C2CK/RST (pin 11) low, you will place the module's protocol controller in hardware reset. In this state, the module is in a safe, stalled state. If your Vdd rise time is greater than 1ms, it will be necessary to hold the module in reset until Vdd reaches 2.7V. There are many reset supervisor ICs that can accomplish this task, such as the Microchip MCP130. See the section on **Rise Time** for more information.

In order to cause the module to enter reset, C2CK/RST must be held low for at least 20µs. Normal operation is restored when this pin is returned high.

Application Information

Pin-out Diagram

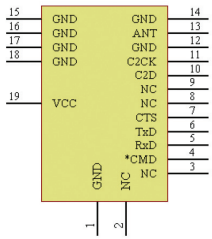

Figure 11: Pinout Diagram

Pin Descriptions

Pin Descriptions	
No.	Description
1	Ground
2	No connect – reserved
3	No connect – reserved
4	Command input – active low
5	UART receive input
6	UART transmit output
7	UART clear to send output – active low
8	No connect – reserve
9	No connect – reserve
10	Reserved – ISP pin C2D
11	ISP pin C2CK/RST
12	Ground
13	Antenna port – 50ohm
14	Ground
15	Ground
16	Ground
17	Ground
18	Ground
19	VCC – 2.7 to 3.6 VDC

Figure 12: Pin Descriptions

Legend

- Signals used in this implementation
- Signals not used in this implementation – do not connect
- Signals used for in-system programming

Mechanical Drawings

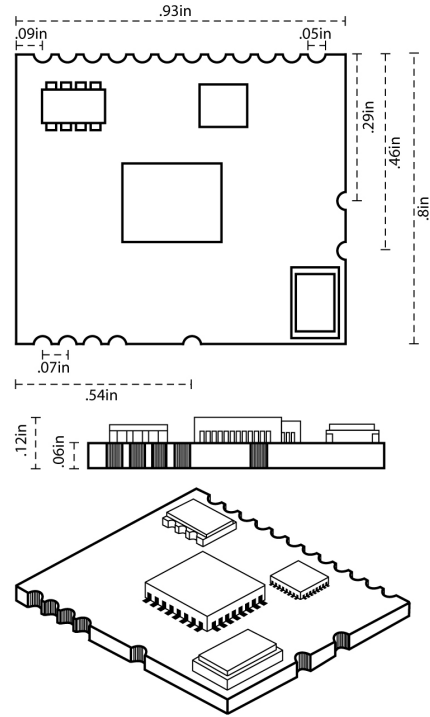

Figure 13: Module Mechanical Drawings

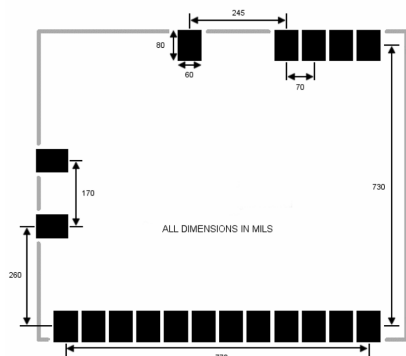

Figure 14: DTS Series Module Suggested Footprint

Example Circuit

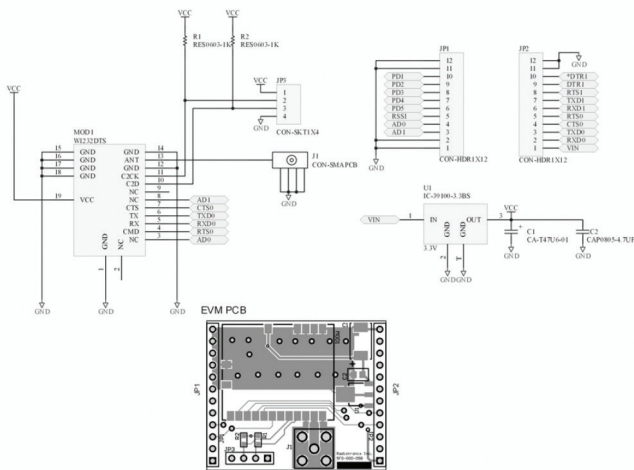

Figure 15: Evaluation Module Circuit

Power Supply

General

Although the DTS Series module is very easy to use, care must be given to the design of the power supply circuit. It is important for the power supply to be free of digital noise generated by other parts of the application circuit, such as the RS-232 converter.

Figure 14 (Suggested Footprint) shows the schematic for our evaluation module circuit for the DTS Series module. It includes an on-board power supply and antenna connector. This evaluation circuit was used to measure the performance of the module, and should be used as a reference for DTS Series based designs. If noise is a problem, it can usually be eliminated by using a dedicated LDO regulator for the module and/or by separating the module grounds and those of the other circuits.

Rise Time

Additionally, power supply rise time is extremely important. The power supply presented to the module must rise from Vss to 2.7V in less than 1ms. If this specification cannot be met, an external reset supervisor circuit must be used to hold the module in reset until the power supply stabilizes. Failure to ensure adequate power supply rise time can result in loss of important module configuration information. See the section on **Hardware Reset** for more information.

UART Interface

The UART interface is very simple; it is comprised of four CMOS compatible digital lines.

Pin Description		
Line	Direction	Description
CTS	Out	Clear to send – this pin indicates to the host micro when it is ok to send data. When CTS is high, the host micro should stop sending data to the module until CTS returns to the low state.
CMD	In	Command – the host micro will bring this pin low to put the module in command mode. Command mode is used to set and read the internal registers that control the operation of the module. When CMD is high, the module will transparently transfer data to and from other modules on the same channel. NOTE: If this pin is low when the module comes out of reset, the non-volatile registers will be reset to their factory programmed defaults. It is important to ensure that CMD is held high or left floating during power-up under normal conditions.
RXD	In	Receive data input.
TXD	Out	Transmit data output.

Figure 16: DTS Series UART Interface Lines

Antenna

The module is designed to work with any 900MHz 50ohm antenna, including PCB trace antennas.

Antenna selection is usually governed by application requirements. In general, external antennas perform better. Linx Technologies has a line of antennas and connectors that are compatible with the modules. Information on these products is available on our website at www.linxtechnologies.com/antennas.

As a rule, a ¼ wave whip or ½ wave dipole antenna with a good, solid ground plane (well-coupled, 3.5" x 3.5" or larger is optimal) is the best choice. Dipoles yield better performance than monopoles (whip) when the ground plane is smaller than optimal. However, many embedded applications cannot support an externally mounted antenna. If this is the case, a PCB antenna must be used. The designer can either use an off-of-the-shelf PCB antenna, such as the ANT-915-SP, or design a trace antenna. There are several good antenna tutorials and references on the Internet and we encourage the designer to use these resources.

Note: Antenna design is difficult and can be impossible without the proper test equipment. As such, we strongly encourage all of our customers to use off-of-the-shelf antennas whenever possible.

Link Budget, Transmit Power and Range Performance

A link budget is the best figure of merit for comparing wireless solutions and determining how they will perform in the field.

In general, the solution with the best link budget will deliver the best line-of-sight range performance. Improving the link budget by increasing the receiver sensitivity will result in lower power consumption, while improving the link budget by increasing the transmit power will result in a more robust performance in the presence of an on-channel interferer or multi-path interference.

The transmit power on unlicensed devices is regulated by the FCC. For transmitters that are not spread-spectrum, the output power is limited to 0dBm (1mW) when a standard ¼ wave whip antenna is used. If the transmitter operates under the spread-spectrum rules, however, the transmit power can be increased; up to 1W depending on the spread-spectrum technique and antennas that are used.

Wireless Fact: Frequency Hopping Spread Spectrum combats in-channel interference, but at the expense of bandwidth, power consumption, and latency. Direct Sequence Spread Spectrum does a better job than FHSS at combating in-channel interference, but at the expensive of occupied bandwidth and power consumption. These spread spectrum techniques are generally chosen because the FCC will allow higher output power from a transmitter employing these techniques. Recently, the FCC rules changed to include a new type of spread spectrum device, called Digital Transmission System (DTS). This method of spread spectrum has no processing gain, but allows lower cost solutions like the DTS Series to transmit with higher output power.

To calculate the link budget for a wireless link, simply add the transmit power, the antenna gains and the receiver sensitivity:

$$LB = Ptx + Gtxa - SENSrx + Grxa$$

For example, the link budget for a pair of modules in DTS mode at the maximum data rate and using 3dBi dipole antennas would be:

$$+11\text{dBm} + 3\text{dB} - (-100\text{dBm}) + 3\text{dB} = 117\text{dB}$$

A link budget of 117dB should easily yield a range of ¼ mile or more outdoors. If the environment is open and the antennas are 8 to 10 feet off of the ground, the range could be a mile. Indoors, this link budget should yield a range of several hundred feet.

This is a well-balanced link budget. More than 10dB of the budget is achieved through transmit power, which will allow good performance indoors in the presence of multi-path while keeping the overall operating current low, making the module suitable for primary battery powered applications such as RFID and automated meter reading.

Module Configuration

Channel Settings

regNVTXCHAN (0x00)					regTXCHAN (0x4B)		
R/W	R/W	R/W	R/W	R/W	R/W	R/W	R/W
RES	D6	D5	D4	D3	D2	D1	D0
7	6	5	4	3	2	1	0

regNVRXCHAN (0x01)					regRXCHAN (0x4C)		
R/W	R/W	R/W	R/W	R/W	R/W	R/W	R/W
RES	D6	D5	D4	D3	D2	D1	D0
7	6	5	4	3	2	1	0

Figure 17: Channel Settings

The North American and Brazilian versions of the DTS Series module supports 32 channels (0–31) in DTS mode and 83 channels (1–83) in low power mode. LP channel 0 is not available in the FCC pre-certified and all Anatel versions of the module; a value of zero in the channel register will select channel 1.

For Brazilian versions, DTS channels 12–17 are aliased to channel 18 and DTS channels 5–11 are aliased to channel 4. Similarly, LP channels 14–29 are aliased to channel 13 and LP channels 30–44 are aliased to channel 45. This is due to the frequency restrictions placed on the 907 to 915MHz sub-band in Brazil, and limits the number of **unique** channels to 19 DTS and 51 LP. All non-aliased channels are compatible with their North American counterparts.

Transmit and receive channels are set in **regTXCHAN (addr 0x4B)** and **regRXCHAN (addr 0x4C)** respectively. **PLEASE NOTE:** If you set the module to have different transmit and receive channels, it will render the CSMA algorithm ineffective.

When the module is in DTS mode, the channel registers are masked so that only the lower 6-bits determine the channel.

The following equations can be used to calculate transmit center frequency in LP and DTS modes, remembering the exceptions listed above for the Anatel versions.

$$F_c = 902.271 + \text{chan} * .3007\text{MHz(LP)}$$

$$F_c = 902.272 + \text{chan} * .7517\text{MHz(DTS)}$$

All modules in a network must be in the same mode (LP or DTS) and must have the same transmit and receive channels programmed in order to communicate properly.

Power Mode

The transmission and reception modes of the module are determined by the settings of the **regPWRMODE** register. It is important to note that a module configured to operate in LP mode cannot “hear” another module transmitting in DTS mode, or vice versa. However, a module configured to operate in any of the three DTS modes can “hear” any other module transmitting in any of the DTS modes (provided that they are within range of one another). LP mode operation must be low power. Additional power settings are included for cases where the antenna circuit is very lossy, such as a PCB loop antenna.

regNVPWRMODE (0x02)					regPWRMODE (0x4D)		
R/W	R/W	R/W	R/W	R/W	R/W	R/W	R/W
NA	NA	NA	NA	NA	PM2	PM1	PM0
7	6	5	4	3	2	1	0

Figure 18: Power Mode

Power Mode Register Settings			
PM1	PM1	PM0	Mode
0	0	0	LP Mode: low power setting
0	0	1	DTS Mode: mid-low power setting
0	1	0	DTS Mode: mid-high power setting
0	1	1	DTS Mode: high power setting
1	0	0	DTS Mode: low power setting
1	0	1	LP Mode: mid-low power setting
1	1	0	LP Mode: mid-high power setting
1	1	1	LP Mode: high power setting

Figure 19: Power Mode Register Settings

DTS Mode

DTS Mode Parameters	
TX Power	-4, +1, +6 or +11dBm
Deviation	±235kHz
TX Current	26 to 72mA
RX Current	16 to 24mA
RX Bandwidth	600kHz

Figure 20: DTS Mode Parameters

Low Power (LP) Mode

In low-power mode, the module is configured as follows:

Low Power Mode Parameters	
TX Power	-4dBm (+1, +6 and +11dBm available)
Deviation	±75kHz
TX Current	26 to 72mA
RX Current	16 to 24mA
RX Bandwidth	200kHz

Figure 21: Low Power Mode Parameters

UART Data Rate

regNVDATARATE (0x03)					regDATARATE (0x4E)		
R/W	R/W	R/W	R/W	R/W	R/W	R/W	R/W
RES	RES	RES	RES	RES	BR2	BR1	BR0
7	6	5	4	3	2	1	0

Figure 22: UART Data Rate

By default, the UART data rate is set to 2.4kbps at the factory. This data rate can be changed by setting the **regDATARATE** register. Valid settings are shown in Figure 23.

Data Rate Register Settings			
Baud Rate	BR2	BR1	BR0
2400	0	0	0
9600	0	0	1
19200	0	1	0
38400	0	1	1
57600	1	0	0
115200	1	0	1
10400*	1	1	0
31250*	1	1	1

* These data rates are not supported by PC serial ports. Selection of these rates may cause the module to fail to respond to a PC, requiring a reset to factory defaults.

Figure 23: Data Rate Register Settings

Troubleshooting Hint: Baud Rate Problems

If you lose track of the baud rate setting of the module, it will be impossible to program the module. You can either try every possible baud rate to discover the setting, or force a power-on reset with CMD held low to set the baud rate to its default: 2.4kbps.

Network Mode

regNVNETMODE (0x04)					regNETMODE (0x4F)		
R/W	R/W	R/W	R/W	R/W	R/W	R/W	R/W
D7	D6	D5	D4	D3	D2	D1	D0
7	6	5	4	3	2	1	0

Figure 24: Network Mode

The module supports two networking modes: Normal and Slave. In normal mode, the module can talk to any other module. In slave mode, the module can talk to normal-mode modules, but cannot transmit to or receive from other slaves. Slave mode is selected by writing 0x00 to this register. The default network mode is 0x01 or 0x80 (Normal Mode).

Transmit Wait Timeout

regNVTXTO (0x05)					regTXTO (0x50)		
R/W	R/W	R/W	R/W	R/W	R/W	R/W	R/W
D7	D6	D5	D4	D3	D2	D1	D0
7	6	5	4	3	2	1	0

Figure 25: Transmit Wait Timeout

When a byte is received from the UART, the module will start a timer that will countdown every millisecond. The timer is restarted when each byte is received.

If the timer reaches zero before the next byte is received from the UART, the module begin transmitting the data in the buffer. Normally, this timeout value should be greater than 0x01 and greater than one byte time at the current UART data rate. If the timeout value is set to 0x00, the transmit wait timeout will not operate, and a full buffer will be required for transmission. When setup this way, the data will be sent only when a full MTU has been received through the UART. The default setting for this register is 0x10 (~16ms delay).

Network Group

regNVNETGRP (0x06)					regNETGRP (0x51)		
R/W	R/W	R/W	R/W	R/W	R/W	R/W	R/W
B7	B6	B5	B4	B3	B2	B1	B0
7	6	5	4	3	2	1	0

Figure 26: Network Group

Modules can be grouped into networks. Although only modules with the group ID will be able to talk to each other, modules in different groups but on the same channel will still coordinate transmissions through the CSMA mechanism. Valid values for this register are 0 to 127. The default group setting is 0.

CRC Control

regVUSECRC (0x08)					regUSECRC (0x53)		
R/W	R/W	R/W	R/W	R/W	R/W	R/W	R/W
B7	B6	B5	B4	B3	B2	B1	B0
7	6	5	4	3	2	1	0

Figure 27: CRC Control

Set to 0x01 to enable receive CRC checking, or 0x00 to disable it. The default CRC mode setting is enabled.

UART Minimum Transmission Unit

regNVUARTMTU (0x09)					regUARTMTU (0x54)		
R/W	R/W	R/W	R/W	R/W	R/W	R/W	R/W
B7	B6	B5	B4	B3	B2	B1	B0
7	6	5	4	3	2	1	0

Figure 28: UART Minimum Transmission Unit

This register determines the UART buffer level that will trigger the transmission of a packet. The minimum value is 1 and the maximum value is 144. The default value for this register is 64, which provides a good mix of throughput and latency

Verbose Mode

regNVSHOWVER (0x0A)					regSHOWVER (0x55)*		
R/W	R/W	R/W	R/W	R/W	R/W	R/W	R/W
B7	B6	B5	B4	B3	B2	B1	B0
7	6	5	4	3	2	1	0

Figure 29: Verbose Mode

Setting this register to 0x00 will suppress the start-up message, including firmware version, which is sent to the UART when the module is reset. A value of 0x01 will cause the message to be displayed after reset. By default, the module start-up message will be displayed.

*The volatile register counterpart (0x55) has no function.

CSMA Enable

regNVCSMAMODE (0x0B)					regCSMAMODE (0x56)		
R/W	R/W	R/W	R/W	R/W	R/W	R/W	R/W
B7	B6	B5	B4	B3	B2	B1	B0
7	6	5	4	3	2	1	0

Figure 30: CSMA Enable

Carrier-sense multiple access (CSMA) is a best-effort delivery system that listens to the channel before transmitting a message. If another Wi.232 module is already transmitting when a message is queued, the module will wait before sending its payload. This helps to eliminate RF message corruption at the expense of additional latency. Setting this register to 0x01 will enable CSMA. Setting this register to 0x00 will disable CSMA. By default, CSMA is enabled.

Sleep Control

regNVSLPMODE (0x0D)					regSLPMODE (0x58)		
R/W	R/W	R/W	R/W	R/W	R/W	R/W	R/W
B7	B6	B5	B4	B3	B2	B1	B0
7	6	5	4	3	2	1	0

Figure 31: Sleep Control

Setting this register to 0x01 will place the module into sleep mode; 0x02 will place the module in Standby mode. Sleep mode places the module in the lowest power inactive state and requires approximately 7–8ms to resume transmission or reception once awakened. Standby draws ~850µA and requires approximately 1–2ms to awaken. To wake up the module, data should be sent to the module's UART. Use a sequence 0x0F, 0xFF, 0xFF. Upon awakening, the module will clear the volatile register to 0x00. The default value for this register is 0x00 (awake).

By default, the module will send an acknowledgement character (0x06) to the UART TxD pin to let the calling application know that it is awake and ready. To control this feature, see “ACK on Wake” in this section.

ACK on Wake

regNVACKONWAKE (0x0E)					regACKONWAKE (0x59)		
R/W	R/W	R/W	R/W	R/W	R/W	R/W	R/W
B7	B6	B5	B4	B3	B2	B1	B0
7	6	5	4	3	2	1	0

32: ACK on Wake

When the module's RF components are ready to transmit/receive, the module can send an ACK character (0x06) to the host through the UART TxD pin. This notification let the host processor know when the module is ready to commence RF communications. Set this register to 0x00 to prevent the sending of this character, or 0x01 to allow the character to be sent. The default value for this register is 0x01.

MAC Address

regMAC5- regMAC0 (0x22-0x27)					N/A		
R	R	R	R	R	R	R	R
D7	D6	D5	D4	D3	D2	D1	D0
7	6	5	4	3	2	1	0

Figure 33: MAC Address

These registers make a unique 48-bit MAC address. These values are factory preset and cannot be altered. These address bytes are not used by the module. They are provided for customer applications as a unique address.

Release Number

regRELEASENUM (0x78)					N/A		
R	R	R	R	R	R	R	R
D7	D6	D5	D4	D3	D2	D1	D0
7	6	5	4	3	2	1	0

Figure 34: Release Number

This register indicates the firmware release number for the module.

Figure 35 translates DTS Series release numbers to firmware versions.

Release Number to Version Number		
Release Number	Module Type	Version Number
0	DTS	1.1.0
1	EUR	1.2.6
2	DTS	1.2.6
3	EUR	1.3.1 (current)
4	DTS	1.3.0 (current)
5	DTS-FCC	1.3.0 (current)
8	DTS-FCC	1.3.0 (current)
18	DTSB	1.3.0 (current)

Figure 35: Release Number to Version Number

Register Summary

Volatile Read/Write Registers		
Name	Address	Description
regTXCHANNEL	0x4B	Transmit channel setting
regRXCHANNEL	0x4C	Receive channel setting
regPWRMODE	0x4D	Operating mode settings
regDATARATE	0x4E	UART data rate
regNETMODE	0x4F	Network mode (normal or slave)
regTXTO	0x50	Transmit wait timeout
regNETGRP	0x51	Network group ID
regUSECRC	0x53	Enable/disable CRC
regUARTMTU	0x54	Minimum transmission unit
regSHOWWER	0x55	Enable/disable start-up message
regCSMAMODE	0x56	Enable/disable CSMA
regSLPMODE	0x58	Power state of module
regACKONWAKE	0x59	Send ACK character to host on wake

Figure 36: Volatile Read/Write Registers

Non-Volatile Read-Only Registers		
Name	Address	Description
regMAC5	0x22	These registers form the unique 48-bit MAC address
regMAC4	0x23	
regMAC3	0x24	
regMAC2	0x25	
regMAC1	0x26	
regMAC0	0x27	
regRELEASENUM	0x78	Firmware release number

Figure 37: Volatile Read-Only Registers

Non-Volatile Registers			
Name	Address	Description	Default
regNVTXCHANNEL	0x00	Transmit channel setting	16
regNVRXCHANNEL	0x01	Receive channel setting	16
regNVPWRMODE	0x02	Operating mode settings	+11dBm DTS mode
regNVDATARATE	0x03	UART data rate	2400bps
regNVNETMODE	0x04	Network mode (Normal/Slave)	Normal
regNVTXTO	0x05	Transmit wait timeout	~16ms
regNVNETGRP	0x06	Network group ID	0x00
regNVUSECRC	0x08	Enable/disable CRC	Enabled
regNVUARTMTU	0x09	Minimum transmission unit	64 bytes
regNVSHOWWER	0x0A	Enable/disable start-up message	Enabled
regNVCSMAMODE	0x0B	Enable/disable CSMA	Enabled
regNVSLPMODE	0x0D	Power state of module	Awake
regNVACKONWAKE	0x0E	Send ACK character to host on wake	Yes

Figure 38: Register Summary

Using Configuration Registers

CMD Pin

The CMD pin is used to inform the module where incoming UART information should be routed. When the CMD pin is high or left floating, all incoming UART information is treated as payload data and transferred over the wireless interface. If the CMD pin is low, the incoming UART data is routed to the command parser for processing. Since the module's processor looks at UART data one byte at a time, the CMD line must be held low for the entire duration of the command plus a 20µs margin for processing. Leaving the CMD pin low for additional time (for example, until the ACK byte is received by your application) will not adversely affect the module. If RF packets are received while the CMD line is active, they are still processed and presented to the module's UART for transmission.



Figure 39: Command and CMD Pin Timing

Command Formatting

The DTS Series module contains several volatile and non-volatile registers that control its configuration and operation. The volatile registers all have a non-volatile mirror registers that are used to determine the default configuration when power is applied to the module. During normal operation, the volatile registers are used to control the module.

Placing the module in the command mode allows these registers to be programmed. Byte values in excess of 127 (0x80 or greater) must be changed into a two-byte escape sequence of the format: 0xFE, [value - 128]. For example, the value 0x83 becomes 0xFE, 0x03. The following function will prepend a 0xFF header and size specifier to a command sequence and create escape sequences as needed. It is assumed that *src is populated with either the register number to read (one byte, pass 1 into src_len) or the register number and value to write (two bytes, pass 2 into src_len). It is also assumed that the *dest buffer has enough space for the two header characters plus, the encoded command, and the null terminator.

```
int EscapeString(char *src, char src_len, char *dest)
{
    // The following function copies and encodes the first
    // src_len characters from *src into *dest. This
    // encoding is necessary for module command formats.
    // The resulting string is null terminated. The size
    // of this string is the function return value.
    // -----
    char src_idx, dest_idx;
    // Save space for the command header and size bytes
    // -----
    dest_idx = 2;
    // Loop through source string and copy/encode
    // -----
    for (src_idx = 0; src_idx < src_len; src_idx++)
    {
        if (src[src_idx] > 127)
        {
            dest[dest_idx++] = 0xFE;
        }/*if*/
        dest[dest_idx++] = (src[src_idx] & 0x7F);
    }/*for*/
    // Add null terminator
    // -----
    dest[dest_idx] = 0;
    // Add command header
    // -----
    dest[0] = 0xFF;
    dest[1] = dest_idx - 2;
    // Return escape string size
    // -----
    return dest_idx;
}
```

Figure 40: Command Conversion Code

Writing to Registers

Writing to a volatile register is nearly instantaneous. Writing to a non-volatile register, however, takes typically 16ms. Because the packet size can vary based on the need for encoding, there are two possible packet structures. The following tables show the byte sequences for writing a register in each case.

Warning: Be sure that the module is properly powered and remains powered for the duration of the register write. Loss of important configuration information could occur if the unit loses power during a non-volatile write cycle.

Byte 0								Byte 1								Byte 2								Byte 3							
Header								Size								Register								Value							
7	6	5	4	3	2	1	0	7	6	5	4	3	2	1	0	7	6	5	4	3	2	1	0	7	6	5	4	3	2	1	0
0xFF								0x02								0	Register							0	Value						

Figure 41: Write Register Command, Value to be written is less than 128 (0x80)

Byte 0								Byte 1								Byte 2								Byte 3								Byte 4							
Header								Size								Register								Escape								Value							
7	6	5	4	3	2	1	0	7	6	5	4	3	2	1	0	7	6	5	4	3	2	1	0	7	6	5	4	3	2	1	0	7	6	5	4	3	2	1	0
0xFF								0x03								0	Register							0xFE								0	Lower 7 bits of Value						

Figure 42: Write Register Command, Value to be written is greater than or equal to 128 (0x80)

The module will respond to this command with an ACK (0x06). If an ACK is not received, the command should be resent. If a write is attempted to a read-only or invalid register, the module will respond with a NAK (0x15).

Reading from Registers

A register read command is constructed by placing an escape character before the register number. The following table shows the byte sequence for reading a register.

Byte 0								Byte 1								Byte 2								Byte 3							
Header								Size								Escape								Register							
7	6	5	4	3	2	1	0	7	6	5	4	3	2	1	0	7	6	5	4	3	2	1	0	7	6	5	4	3	2	1	0
0xFF								0x02								0xFE								0	Register						

Figure 43: Read Register Command

The module will respond to this command by sending an ACK (0x06) followed by the register number and register value. The register value is sent unmodified. For example, if the register value is 0x83, 0x83 is returned after the ACK (0x06). See table below for the format of the response. If the register number is invalid, it will respond with a NACK (0x15).

Byte 0								Byte 1								Byte 2							
ACK								Register								Value							
7	6	5	4	3	2	1	0	7	6	5	4	3	2	1	0	7	6	5	4	3	2	1	0
0x06								0	Register							Value							

Figure 44: Read Register Module Response for a Valid Register

AC Specifications – TX					
Parameter	Min.	Typ.	Max.	Units	Notes
Transmit Frequency	902.2		927.8	MHz	
Maximum Effective RF Data Rate		100		kbps	Encoding/over-head losses included, 144 byte MTU
Center Frequency Error		2	5	ppm	915MHz at 25°C
Frequency Deviation: DTS Mode		235		kHz	
Frequency Deviation: LP Mode		75		kHz	
Low Output Power, Conducted		-4	-1	dBm	915MHz into 50ohm load
Mid-Low Output Power, Conducted		1	4	dBm	915MHz into 50ohm load
Mid-High Output Power, Conducted		11	14	dBm	915MHz into 50ohm load
Output Impedance		50		ohms	915MHz into 50ohm load
Carrier Phase Noise		TBD		dBc	Into 50ohm load
Harmonic Output		-50		dBc	Into 50ohm load

Figure 45: AC Specifications – TX

DC Specifications					
Parameter	Min.	Typ.	Max.	Units	Notes
Operating Temperature	-40		+85	°C	HW Revision C and later
Supply Voltage	2.7	3.3	3.6	VDC	
Receive Current Consumption		16-24		mA	Continuous operation, Cdd = 3.3VDC, varies with UART data rate selected
Transmit Current Consumption					
Low Power		26-35		mA	Output into 50-ohm load, Vdd=3.3VDC, depends on data rate selected
Mid-Low Power		33-44		mA	
Mid-High Power		48-56		mA	
High Power		63-72		mA	
Standby Current Consumption		850		µA	Vdd = 3.3VDC
Sleep Current Consumption		35		µA	Vdd = 3.3VDC
Vih: Logic High Level Input	0.7*Vcc		5.0	VDC	
Vil: Logic Low Level Input	0		0.3*Vcc	VDC	
Voh: Logic High Level Output	2.5		Vcc	VDC	
Vol: Logic Low Level Output	0		0.4	VDC	

Figure 46: DC Specifications

Flash Specifications (Non-Volatile Registers)					
Parameter	Min.	Typ.	Max.	Units	Notes
Flash Write Duration		16	21	ms	Module stalled during write operation
Flash Write Cycles	20k	100k		cycles	

Figure 47: Flash Specifications (Non-Volatile Registers)

Custom Applications

For cost-sensitive applications, such as wireless sensors and AMR, Linx Technologies can embed the application software directly into the microcontroller built into the module. For more information on this service, please contact Linx Technologies.

Ordering Information

Ordering Information		
Product Part No.	Description	Radiotronic Part No.
TRM-915-DTS	North American Embedded Wireless Module (902–928Hz)	Wi.232DTS-R
TRM-915-DTS-BRZ	Brazilian Embedded Wireless Module (902–907, 915–928MHz)	Wi.232DTSB-R
TRM-868-EUR	European Union Embedded Wireless Module (868–870MHz)	Wi.232EUR

Figure 48: Ordering Information



Linx Technologies
159 Ort Lane
Merlin, OR, US 97532

3090 Sterling Circle, Suite 200
Boulder, CO 80301

Phone: +1 541 471 6256
Fax: +1 541 471 6251
www.linxtechnologies.com

Disclaimer

Linx Technologies is continually striving to improve the quality and function of its products. For this reason, we reserve the right to make changes to our products without notice. The information contained in this Data Guide is believed to be accurate as of the time of publication. Specifications are based on representative lot samples. Values may vary from lot-to-lot and are not guaranteed. "Typical" parameters can and do vary over lots and application. Linx Technologies makes no guarantee, warranty, or representation regarding the suitability of any product for use in any specific application. It is Customer's responsibility to verify the suitability of the part for the intended application. At Customer's request, Linx Technologies may provide advice and assistance in designing systems and remote control devices that employ Linx Technologies RF products, but responsibility for the ultimate design and use of any such systems and devices remains entirely with Customer and/or user of the RF products.

LINX TECHNOLOGIES DISCLAIMS ANY AND ALL WARRANTIES OF MERCHANTABILITY AND FITNESS FOR A PARTICULAR PURPOSE. IN NO EVENT SHALL LINX TECHNOLOGIES BE LIABLE FOR ANY CUSTOMER'S OR USER'S INCIDENTAL OR CONSEQUENTIAL DAMAGES ARISING OUT OF OR RELATED TO THE DESIGN OR USE OF A REMOTE CONTROL SYSTEM OR DEVICE EMPLOYING LINX TECHNOLOGIES RF PRODUCTS OR FOR ANY OTHER BREACH OF CONTRACT BY LINX TECHNOLOGIES. CUSTOMER AND/OR USER ASSUME ALL RISKS OF DEATH, BODILY INJURIES, OR PROPERTY DAMAGE ARISING OUT OF OR RELATED TO THE USE OF LINX TECHNOLOGIES RF PRODUCTS, INCLUDING WITH RESPECT TO ANY SERVICES PROVIDED BY LINX RELATED TO THE USE OF LINX TECHNOLOGIES RF PRODUCTS. LINX TECHNOLOGIES SHALL NOT BE LIABLE UNDER ANY CIRCUMSTANCES FOR A CUSTOMER'S, USER'S, OR OTHER PERSON'S DEATH, BODILY INJURY, OR PROPERTY DAMAGE ARISING OUT OF OR RELATED TO THE DESIGN OR USE OF A REMOTE CONTROL SYSTEM OR DEVICE EMPLOYING LINX TECHNOLOGIES RF PRODUCTS.

The limitations on Linx Technologies' liability are applicable to any and all claims or theories of recovery asserted by Customer, including, without limitation, breach of contract, breach of warranty, strict liability, or negligence. Customer assumes all liability (including, without limitation, liability for injury to person or property, economic loss, or business interruption) for all claims, including claims from third parties, arising from the use of the Products. Under no conditions will Linx Technologies be responsible for losses arising from the use or failure of the device in any application, other than the repair, replacement, or refund limited to the original product purchase price. Devices described in this publication may contain proprietary, patented, or copyrighted techniques, components, or materials.

All rights reserved. ©2012 Linx Technologies

The stylized Linx logo, Wireless Made Simple, CipherLinx, WiSE and the stylized CL logo are trademarks of Linx Technologies.