



EVM-915-250

Data Guide
(Preliminary)

Wireless made simple[®]

Table of Contents

- 1 [Description](#)
- 2 [Ordering Information](#)
- 2 [Electrical Specifications](#)
- 4 [Pin Assignments](#)
- 5 [Pin Descriptions](#)
- 6 [PCB Footprint](#)
- 7 [Schematic Diagram](#)
- 8 [Usage Guidelines for FCC Compliance](#)
 - 8 [Antenna Selection](#)
 - 8 [Module Modification](#)
 - 8 [End Product Labeling Requirements](#)
- 9 [Additional FCC Testing Requirements](#)
- 10 [FCC Statements of Modular Compliance](#)
- 11 [Customer FCC Warning Requirements](#)

EVM-915-250

Data Guide (Preliminary)



Description

The EVM-915-250 evaluation module supports developments with the TRM-915-R250 embedded radio module.

The EVM-915-250 module combines a state-of-the-art low power wireless transceiver with a powerful multipoint-to-multipoint protocol controller to form a complete wireless communication solution. With a simple UART interface, a 130dB link budget and very low power operation modes. The module is excellent for Automatic Meter Reading (AMR), fleet management, RFID, gas and oil sensing, Home Automation, and many other cable replacement applications requiring long range and long battery life.



Figure 1: EVM-915-250-FCx

The module can operate as a transparent wire replacement solution. It can also operate in a peer-to-peer networked mode that supports node addressing and assured delivery. The module is designed to be totally transparent. Data is validated using an internally generated CRC-16 and encoded using a proprietary Frequency Hopping Spread Spectrum algorithm. Multiple modules can operate on the same channel because of the built-in carrier-sense-multiple-access (CSMA) protocol.

Ordering Information

Ordering Information		
Product Part No.	Description	Radiotronics Part No.
EVM-915-250-FCR	TRM-915-R250 Evaluation Module, Right Angle RP-SMA Connector, FCC Approved	Wi.232FHSS-250-FCC-RA-R
EVM-915-250-FCS	TRM-915-R250 Evaluation Module, Straight RP-SMA Connector, FCC Approved	Wi.232FHSS-250-FCC-ST-R
EVM-915-250-BZR	TRM-915-R250 Evaluation Module, Right Angle RP-SMA Connector, Brazil Anatel Approved	Wi.232FHSS-250B-RA-R
EVM-915-250-BZS	TRM-915-R250 Evaluation Module, Straight RP-SMA Connector, Brazil Anatel Approved	Wi.232FHSS-250B-ST-R
EVM-915-250-CFR	TRM-915-R250 Evaluation Module, Right Angle SP-SMA Connector, Mexico CoFeTel Approved	Wi.232FHSS-250-FCC-CFTC-RA-R
EVM-915-250-CFS	TRM-915-R250 Evaluation Module, Straight RP-SMA Connector, Mexico CoFeTel Approved	Wi.232FHSS-250-FCC-CFTC-ST-R

Figure 2: Ordering Information

Electrical Specifications

Electrical Specifications						
Parameter	Designation	Min.	Typ.	Max.	Units	Notes
Power Supply						
Operating Voltage	V_{CC}	4		12	VDC	
Supply Current	I_{CC}					
Receive				25	mA	
Transmit, $P_o = 8\text{dBm}$				60	mA	
Transmit, $P_o = 23.5\text{dBm}$				200	mA	
Digital Interface						
Output						
Logic Low	V_{OL}	0		0.4	VDC	
Logic High	V_{OH}	2.5		V_{CC}	VDC	

Electrical Specifications Continuation						
Parameter	Designation	Min.	Typ.	Max.	Units	Notes
Input						
Logic Low	V_{IL}	0		$0.3 \cdot V_{CC}$	VDC	
Logic High	V_{IH}	$0.7 \cdot V_{CC}$		V_{CC}	VDC	
Environmental						
Operating Temperature Range		-40		85	°C	

Figure 3: Electrical Specifications

Warning: Linx radio frequency ("RF") products may be used to control machinery or devices remotely, including machinery or devices that can cause death, bodily injuries, and/or property damage if improperly or inadvertently triggered, particularly in industrial settings or other applications implicating life-safety concerns. No Linx Technologies product is intended for use in any application without redundancies where the safety of life or property is at risk.

The customers and users of devices and machinery controlled with RF products must understand and must use all appropriate safety procedures in connection with the devices, including without limitation, using appropriate safety procedures to prevent inadvertent triggering by the user of the device and using appropriate security codes to prevent triggering of the remote controlled machine or device by users of other remote controllers.

All RF products are susceptible to RF interface that can prevent communication.

Do not use any Linx product over the limits in this data guide. Excessive voltage or extended operation at the maximum voltage could cause product failure. Exceeding the reflow temperature profile could cause product failure which is not immediately evident.

Do not make any physical or electrical modifications to any Linx product. This will void the warranty and regulatory and UL certifications and may cause product failure which is not immediately evident.

Pin Assignments

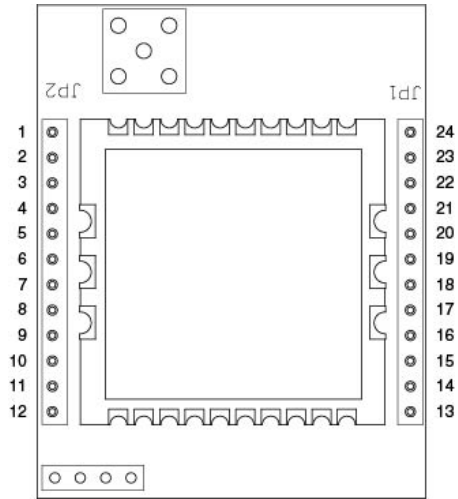

Figure 3: Pin Assignments

Pin Descriptions

Pin Descriptions		
Pin No.	Name	Description
1	Vcc	4V to 12V Supply Voltage
2	RXD0	Serial Port Receive Data
3	TXD0	Serial Port Transmit Data
4	CTS0	Serial Port Clear To Send
5	COMMAND	Command
6	N/C	No Electrical Connection
7	N/C	No Electrical Connection
8	N/C	No Electrical Connection
9	N/C	No Electrical Connection
10	N/C	No Electrical Connection
11	GND	Analog Ground
12	GND	Analog Ground
13	GND	Analog Ground
14	GND	Analog Ground
15	N/C	No Electrical Connection
16	N/C	No Electrical Connection
17	N/C	No Electrical Connection
18	N/C	No Electrical Connection
19	PD5-EX	Exception
20	RSSI	Received Signal Strength Indicator
21	AD0-CMD_RSP	Command Response
22	AD1-BE	Buffer Empty
23	GND	Analog Ground
24	GND	Analog Ground

Figure 4: Pin Descriptions

PCB Footprint

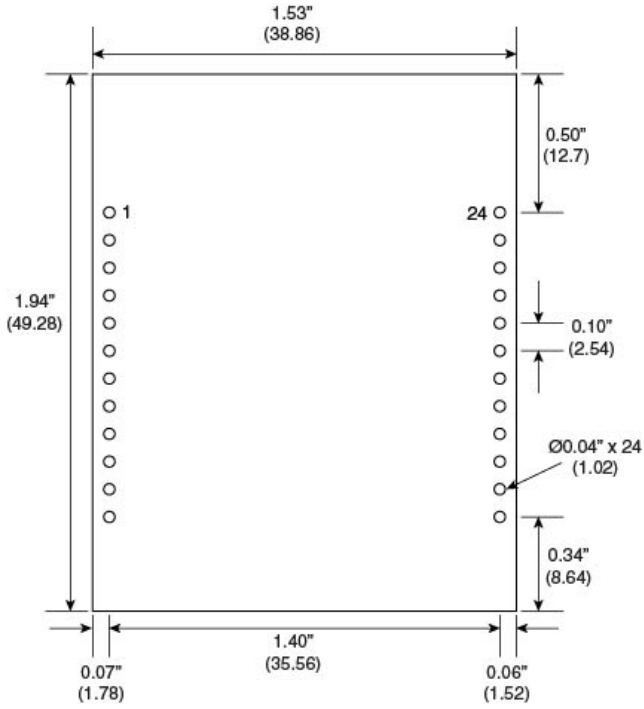

Figure 5: PCB Footprint

Schematic Diagram

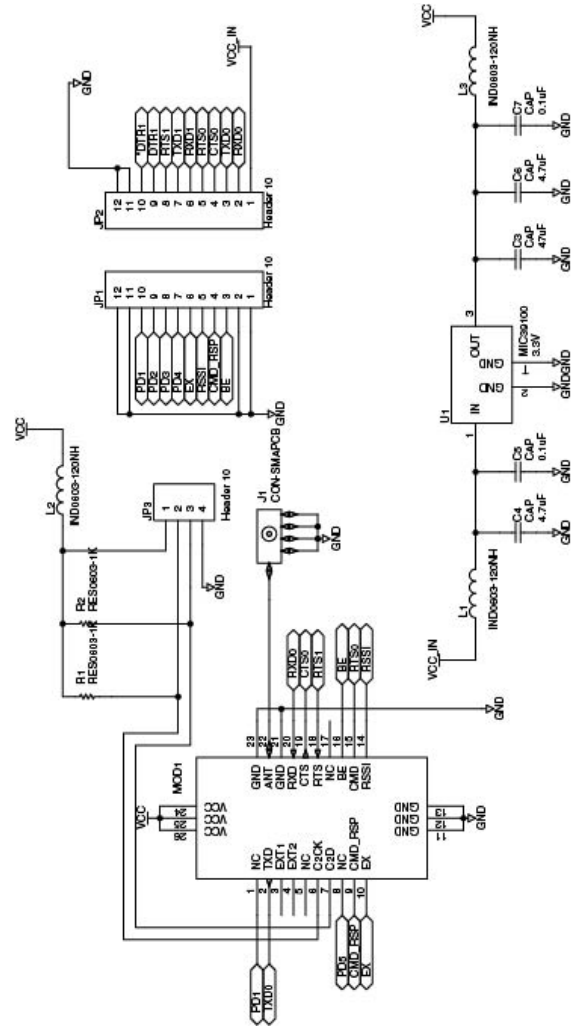

Figure 6: Schematic

Usage Guidelines for FCC Compliance

The EVM-915-250-FCx modules have been awarded a FCC and IC modular approval. The EVM-915-250-BZx have passed Anatel compliance testing. That means that this module, when integrated into your end product, requires no FCC part 15 or IC RSS-210 testing as long as the following guidelines are met. Failure to meet any of the following guidelines will prevent the inheritance of the FCC and IC modular certifications.

Antenna Selection

In order to maintain compliance with FCC, Industry Canada and Anatel regulations, an antenna with no more than 3dBi gain must be used. This module has been tested with the following antennas:

Link Part No.	Antenna Type	Antenna gain
ANT-916-CW-HW	RP ½ Wave Dipole	2.5dBi

Figure 7: Antenna Selection

An approved antenna must be directly attached to the module's reverse-polarity SMA connector or through an approved shielded coaxial extension cable in the final application to inherit the FCC and IC modular certifications.

Module Modification

The module must not be physically altered in any way. If any connections are made to the modules that bypass the module pins, socket or antenna connector, the certifications cannot be inherited.

End Product Labeling Requirements

Pursuant to FCC public notice DA 00-1407, the end product must be labeled on its exterior with the following:

"Contains FCC ID: Q7V-3F090009X"

Additional FCC Testing Requirements

While the module's FCC certification can be inherited if the guidelines are met, additional testing will be required to achieve full FCC compliance for the end-product. The integrator is required to perform unintentional radiator testing on the final product per FCC sections 15.107 and 15.109. Additional product-specific testing might be required. Please contact the FCC regarding regulatory requirements for your application. Ultimately it is the integrator's responsibility to show that their product complies with the regulations applicable to their product.

FCC Statements of Modular Compliance

FCC / IC NOTICE (FCC ID: Q7V-3F090009X / IC: 5589A-3F090009)

This device complies with the rules set forth in Part 15 by the Federal Communications Commission and RSS-210/RSS-Gen by Industry Canada. Operation is subject to the following two conditions:

1. This device may not cause harmful interference
2. This device must accept any interference received, including interference that may cause undesired operation.

Any changes or modifications not expressly approved by Linx Technologies could void the user's authority to operate the equipment.

The EVM-915-250-FCx module is provided with an inheritable FCC Modular Certification. This certification may be inherited in an end-user product, negating the need for FCC part 15 and IC RSS-210 intentional radiator testing on this module, provided that the following guidelines are met:

1. An approved antenna must be directly coupled to the module's RP-SMA connector or through an approved coaxial extension cable.
2. The module must not be modified in any way. Coupling of external circuitry must not bypass the provided connectors.
3. End product must be externally labeled with "Contains FCC ID: Q7V-3F090009X / IC: 5589A-3F090009"
4. The end product's user's manual must contain an FCC statement equivalent to that listed on page 8 of this manual.
5. The antenna used for this transceiver must not be co-located or operating in conjunction with any other antenna or transmitter.
6. The integrator must not provide any information to the end-user on how to install or remove the module from the end-product.

The integrator is required to perform unintentional radiator testing on the final product per FCC sections 15.107 and 15.109.

FCC/IC Pre-certified EVM-915-250

FCC ID: Q7V-3F090009X

IC: 5589A-3F090009

Customer FCC Warning Requirements

The end-product user's manual must contain the following or equivalent statements.

FCC / IC NOTICE

(Containing FCC ID: Q7V-3F090009X / IC: 5589A-3F090009)

The RF module (FCC ID: Q7V-3F090009X / IC: 5589A-3F090009) contained within this device complies with the rules set forth in Part 15 by the Federal Communications Commission and RSS-210/Gen by Industry Canada. Operation is subject to the following conditions:

1. This device may not cause harmful interference
2. This device must accept any interference received, including interference that may cause undesired operation.
3. An approved antenna must be directly coupled to the module's RP-SMA connector or through an approved coaxial extension cable.
4. The module must not be modified in any way. Coupling of external circuitry must not bypass the provided connectors.
5. The antenna used for this transceiver must not be co-located or operating in conjunction with any other antenna or transmitter.

Any changes or modifications could void the user's authority to operate the equipment.

FCC/IC Pre-certified EVM-915-250

FCC ID: Q7V-3F090009X

IC: 5589A-3F090009



Linx Technologies
159 Ort Lane
Merlin, OR, US 97532

3090 Sterling Circle, Suite 200
Boulder, CO 80301

Phone: +1 541 471 6256
Fax: +1 541 471 6251
www.linxtechnologies.com

Disclaimer

Linx Technologies is continually striving to improve the quality and function of its products. For this reason, we reserve the right to make changes to our products without notice. The information contained in this Data Guide is believed to be accurate as of the time of publication. Specifications are based on representative lot samples. Values may vary from lot-to-lot and are not guaranteed. "Typical" parameters can and do vary over lots and application. Linx Technologies makes no guarantee, warranty, or representation regarding the suitability of any product for use in any specific application. It is Customer's responsibility to verify the suitability of the part for the intended application. At Customer's request, Linx Technologies may provide advice and assistance in designing systems and remote control devices that employ Linx Technologies RF products, but responsibility for the ultimate design and use of any such systems and devices remains entirely with Customer and/or user of the RF products.

LINX TECHNOLOGIES DISCLAIMS ANY AND ALL WARRANTIES OF MERCHANTABILITY AND FITNESS FOR A PARTICULAR PURPOSE. IN NO EVENT SHALL LINX TECHNOLOGIES BE LIABLE FOR ANY CUSTOMER'S OR USER'S INCIDENTAL OR CONSEQUENTIAL DAMAGES ARISING OUT OF OR RELATED TO THE DESIGN OR USE OF A REMOTE CONTROL SYSTEM OR DEVICE EMPLOYING LINX TECHNOLOGIES RF PRODUCTS OR FOR ANY OTHER BREACH OF CONTRACT BY LINX TECHNOLOGIES. CUSTOMER AND/OR USER ASSUME ALL RISKS OF DEATH, BODILY INJURIES, OR PROPERTY DAMAGE ARISING OUT OF OR RELATED TO THE USE OF LINX TECHNOLOGIES RF PRODUCTS, INCLUDING WITH RESPECT TO ANY SERVICES PROVIDED BY LINX RELATED TO THE USE OF LINX TECHNOLOGIES RF PRODUCTS. LINX TECHNOLOGIES SHALL NOT BE LIABLE UNDER ANY CIRCUMSTANCES FOR A CUSTOMER'S, USER'S, OR OTHER PERSON'S DEATH, BODILY INJURY, OR PROPERTY DAMAGE ARISING OUT OF OR RELATED TO THE DESIGN OR USE OF A REMOTE CONTROL SYSTEM OR DEVICE EMPLOYING LINX TECHNOLOGIES RF PRODUCTS.

The limitations on Linx Technologies' liability are applicable to any and all claims or theories of recovery asserted by Customer, including, without limitation, breach of contract, breach of warranty, strict liability, or negligence. Customer assumes all liability (including, without limitation, liability for injury to person or property, economic loss, or business interruption) for all claims, including claims from third parties, arising from the use of the Products. Under no conditions will Linx Technologies be responsible for losses arising from the use or failure of the device in any application, other than the repair, replacement, or refund limited to the original product purchase price. Devices described in this publication may contain proprietary, patented, or copyrighted techniques, components, or materials.

All rights reserved. ©2012 Linx Technologies

The stylized Linx logo, Wireless Made Simple, CipherLinx, WiSE and the stylized CL logo are trademarks of Linx Technologies.