

GENERAL DESCRIPTION

The Exar XRP2525/XRP2526 Evaluation board (EVB) is a full assembled and tested surface-mount PCB that demonstrates the XRP2525 (single-channel) and XRP2526 (dual-channel) integrated high-side power distribution switches.

Optimized for USB V_{BUS} power distribution, the XRP2525 and XRP2526 are compliant with the latest USB 3.0 specification and can be used in any self or bus powered USB applications.

The XRP2525 and XRP2526 are pin and function compatible to respectively Exar’s SP2525A and SP2526A. They are offered in a RoHS compliant “green”/halogen free 8-pin NSOIC package.

STANDARD CONFIGURATION

The XRP2525/2526EVB is configured to operate under the following conditions:

Input voltage range V_{IN} : 1.8V – 5.5V

EVALUATION BOARD MANUAL

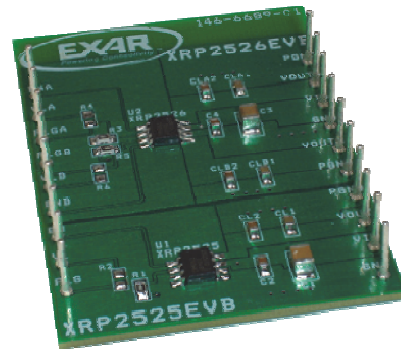

FEATURES

- **Single/Dual Channel Current Switch**
 - 900mA per channel capable
 - 1.8V to 5.5V Input Voltage Range
- **USB 2.0/3.0 Compliant**
- **Active High or Low Individual Enable**
- **Individual Channel Fault Flag Indicator**
- **UVLO, Reverse Current & Thermal Shutdown Protection**

EVALUATION BOARD SCHEMATICS

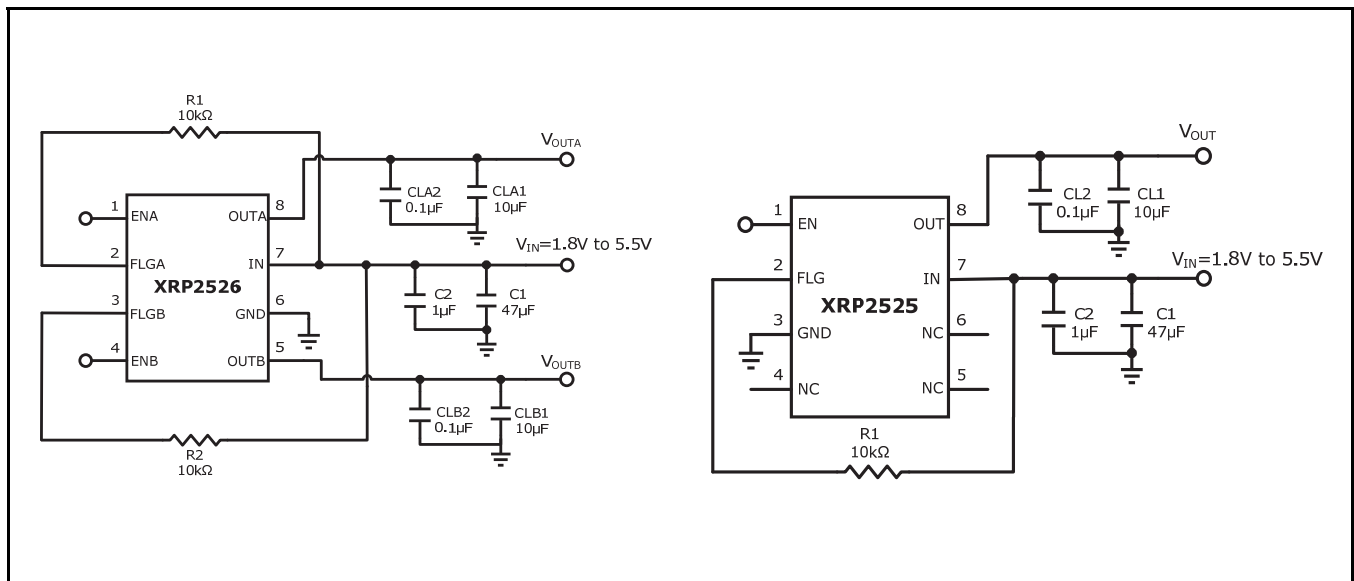

Fig. 1: XRP2525/2526 Evaluation Board Schematics

PIN ASSIGNMENT

Fig. 2: XRP2525/2526 Pin Assignment

PIN DESCRIPTION – XRP2525

Name	Pin Number	Description
EN	1	Channel Enable Input Active High for XRP2525-1 and Active Low for XRP2525-2
FLG	2	Error Flag Signal Active low open drain output. Active on over-current, over-temperature or UVLO conditions.
GND	3	Ground Signal
NC	4,5,6	No Connect
IN	7	Voltage Input Pin
OUT	8	Voltage Output Pin

PIN DESCRIPTION – XRP2526

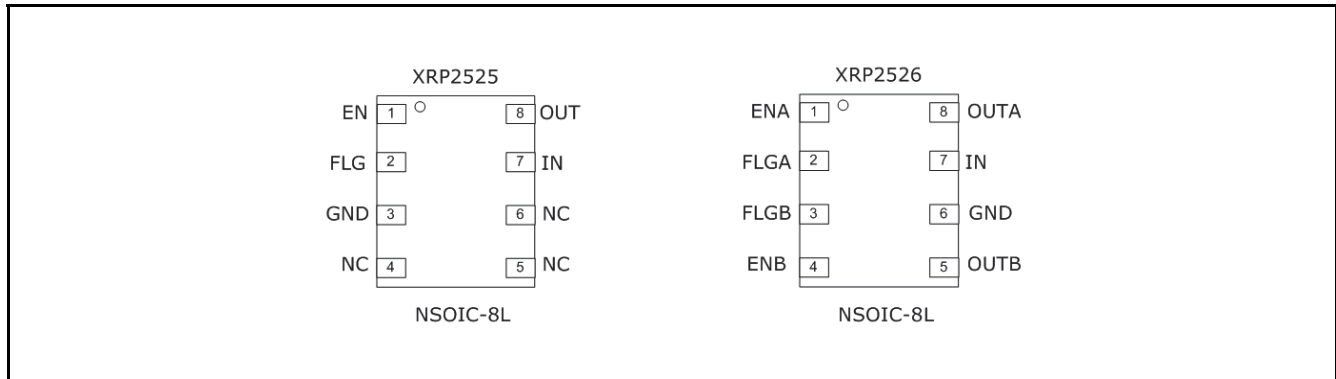
Name	Pin Number	Description
EN _x	1,4	Channel Enable Input Active High for XRP2526-1 and Active Low for XRP2526-2
FLG _x	2,3	Error Flag Signal Active low open drain output. Active on over-current, over-temperature or UVLO conditions.
GND	6	Ground Signal
IN	7	Voltage Input Pin
OUT _x	5,8	Voltage Output Pin

ORDERING INFORMATION

Refer to XRP2525/2526's datasheet and/or www.exar.com for exact and up to date ordering information.

USING THE EVALUATION BOARD

INITIAL SETUP

The Board is supplied from EXAR with the XRP2525-1 and XRP2526-1 devices. Set the input supply to a voltage between 1.8V to 5.5V and connect it to VIN1/VIN2 and GND connectors on the right side of the evaluation board.

Enable pin must be pulled up HIGH to enable the IC. Connect the load to the VOUT and PGND connectors on the right hand side of the board.

Flag pin is pulled up to VIN1/VIN2 through a 10kΩ resistor (provided by default on the board) or can instead be connected to a separate external power supply voltage VL/VL1/VL2.

The board will power-up upon turning on the input supply and reach the desired output voltage. The board can operate with a load current I_{OUT} of up to 900mA per channel.

TYPICAL PERFORMANCE CHARACTERISTICS

All data taken at V_{IN} = 5V, C_{IN} = 47μF//1μF, C_{OUT} = 10μF, T_J = T_A = 25°C, unless otherwise specified - Schematic and BOM from Application Information section of this datasheet.

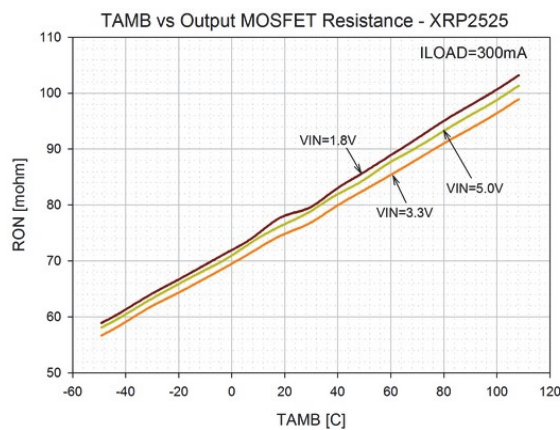

Fig. 3: Output On-Resistance vs. Temperature (XRP2525)

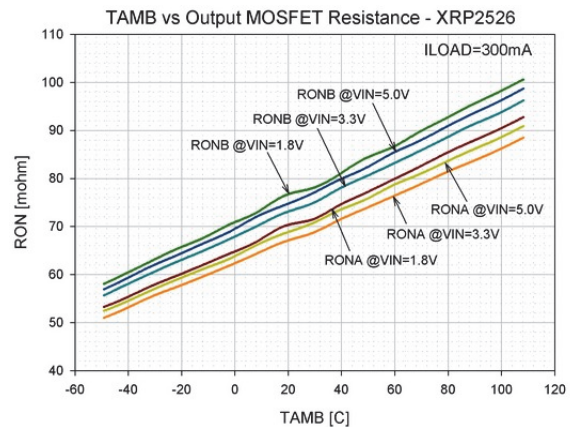

Fig. 4: Output On-Resistance vs. Temperature (XRP2526)

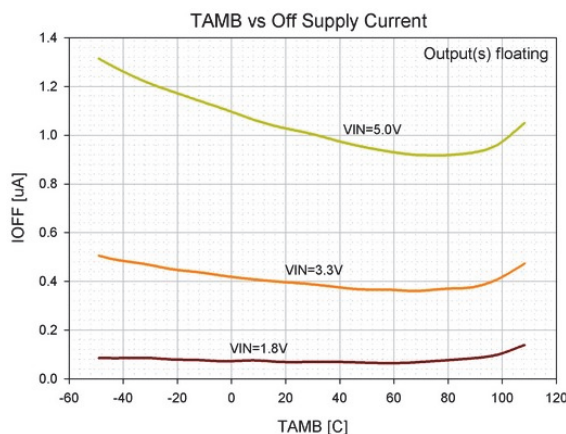

Fig. 5: Off Supply Current vs. Temperature

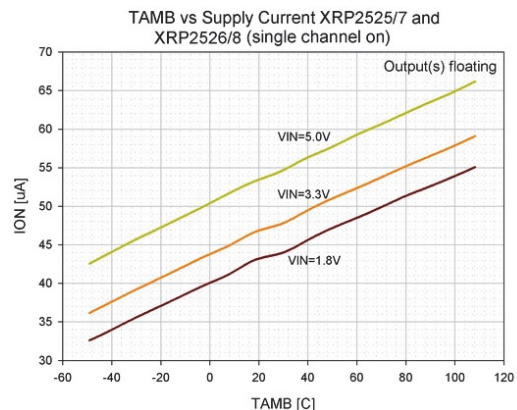

Fig. 6: Quiescent Current vs. Temperature XRP2525 and XRP2526 (1-channel on)

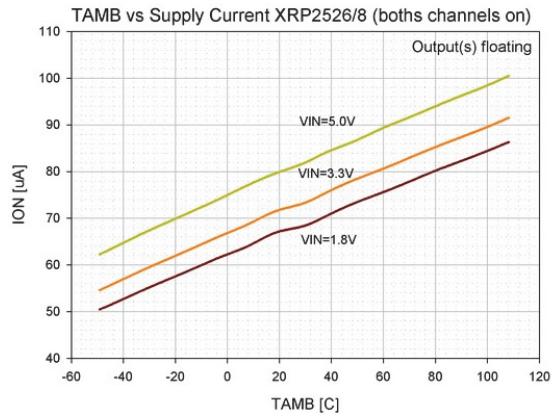

Fig. 7: Quiescent Current vs. Temperature XRP2526 (2-channels on)

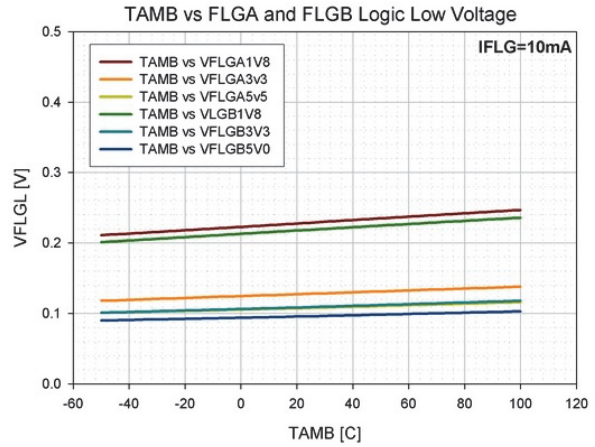

Fig. 8: FLG Logic Low Voltage vs. Temperature

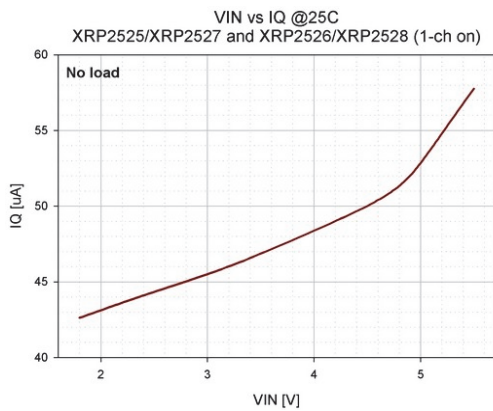

Fig. 9: Quiescent Current vs. Input Voltage XRP2525 and XRP2526 (1-channel on)

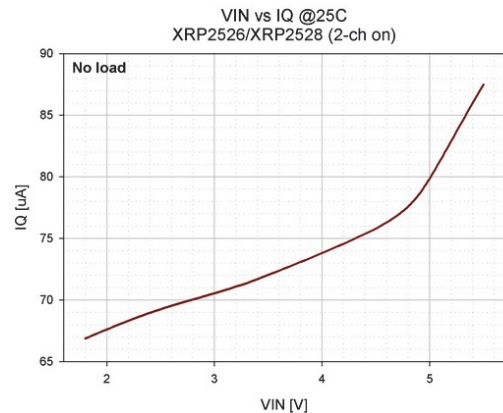

Fig. 10: Quiescent Current vs. Input Voltage XRP2526 (2-channels on)

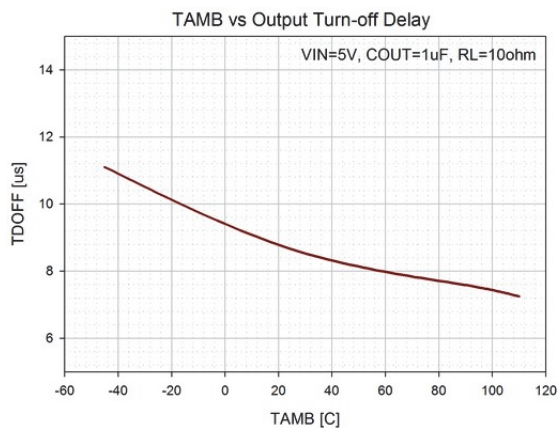

Fig. 11: Output Turn-Off Delay vs. Temperature

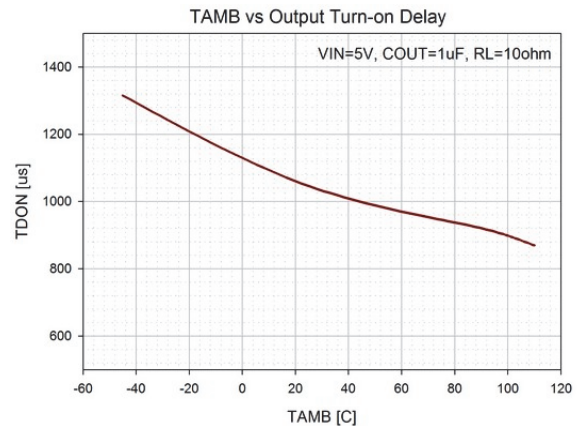

Fig. 12: Output Turn-on Delay vs. Temperature

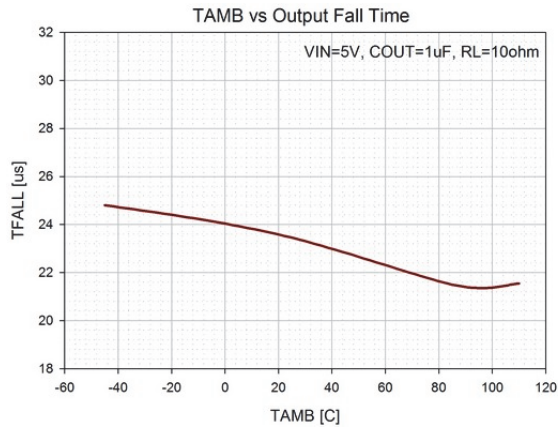

Fig. 13: Output Fall Time vs. Temperature

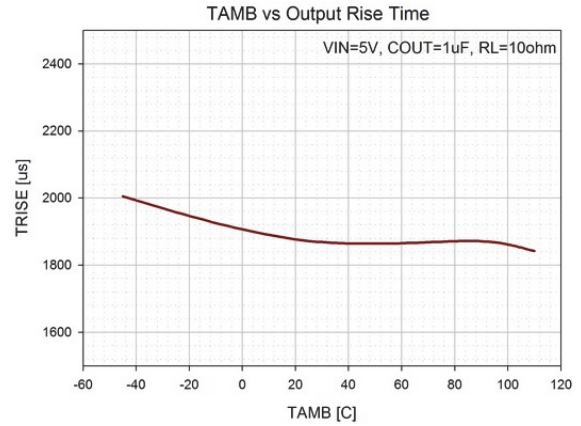

Fig. 14: Output Rise Time vs. Temperature

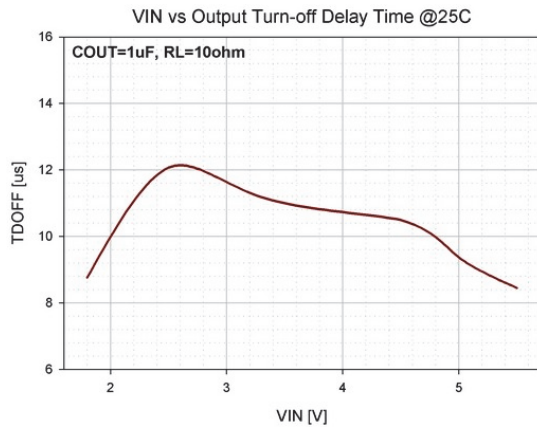

Fig. 15: Output Turn-Off Delay Time vs. Input Voltage

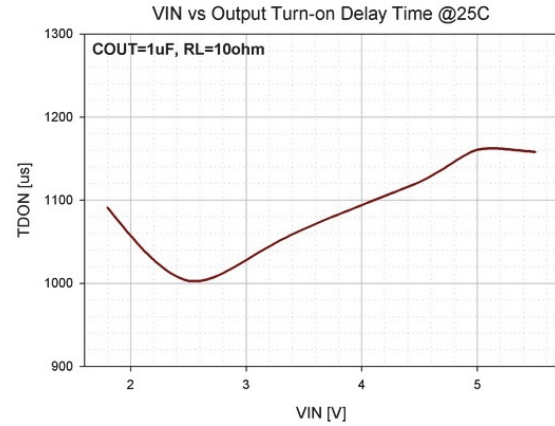

Fig. 16: Output Turn-On Delay Time vs. Input Voltage

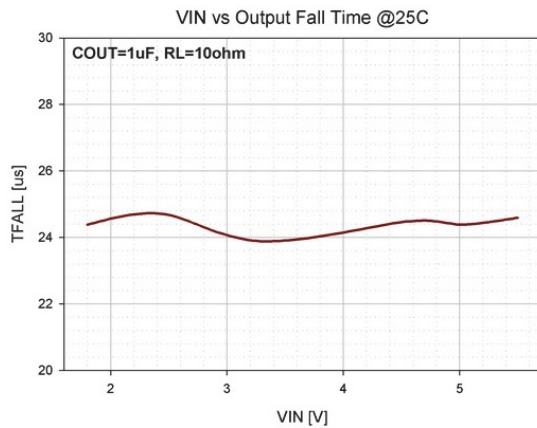

Fig. 17: Output Fall Time vs. Input Voltage

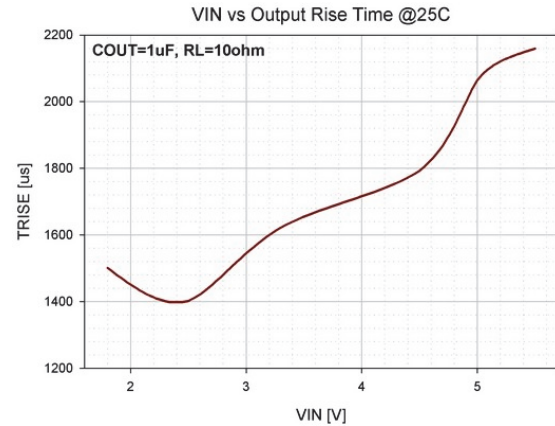

Fig. 18: Output Rise Time vs. Input Voltage

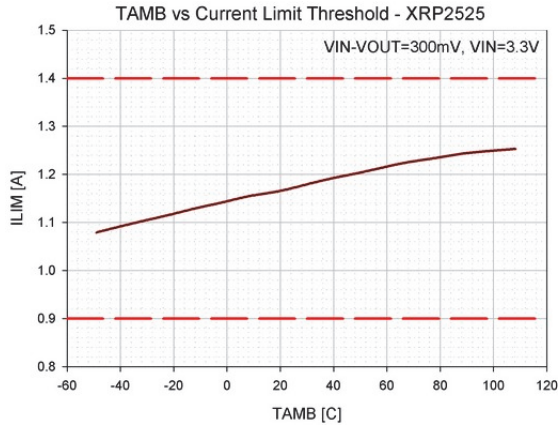

Fig. 19: Current Limit Threshold vs. Temperature (XRP2525)

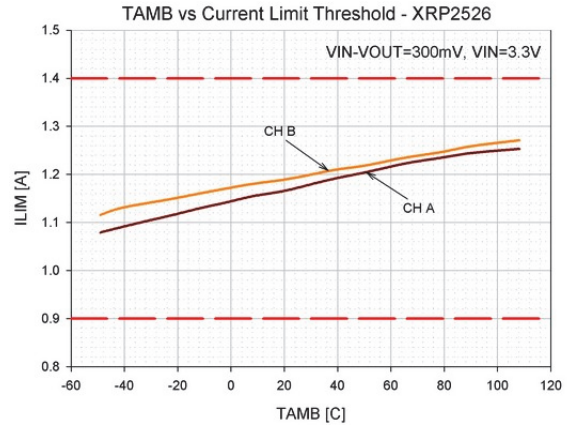

Fig. 20: Current Limit Threshold vs. Temperature (XRP2526)

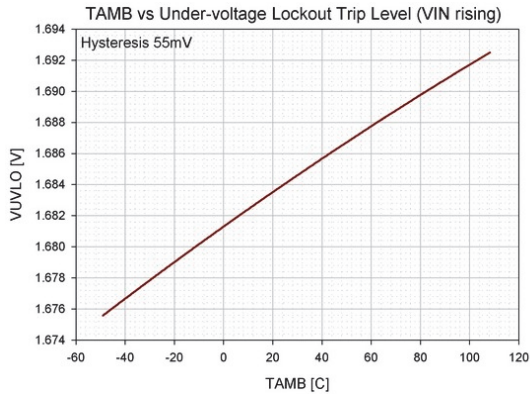

Fig. 21: Under-voltage lockout trip level vs. Temperature (VIN Rising)

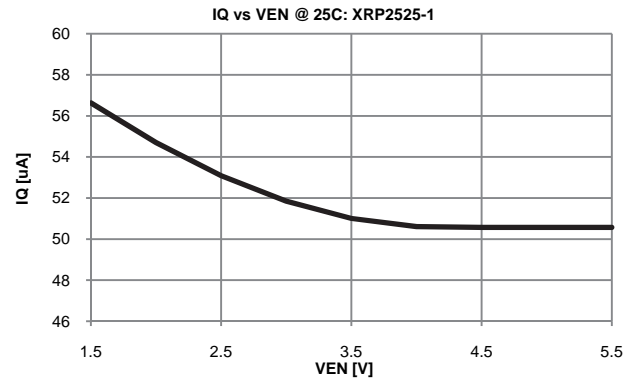

Fig. 22: Quiescent Current vs. Enable pin Voltage XRP2525-1

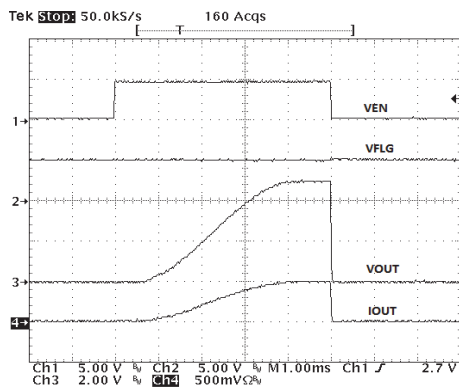

Fig. 23: Turn-On, Turn-Off Characteristics (XRP2526-1) COUT = 1uF, Rload = 10Ω

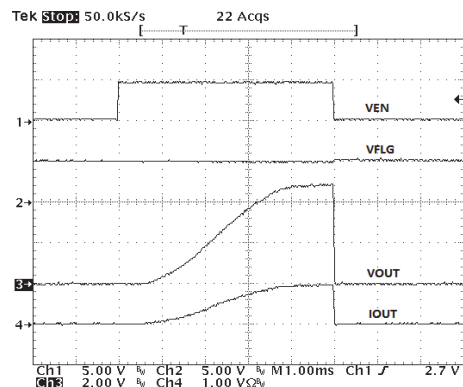

Fig. 24: Turn-On, Turn-Off Characteristics (XRP2526-1) COUT = 1uF, Rload = 5Ω

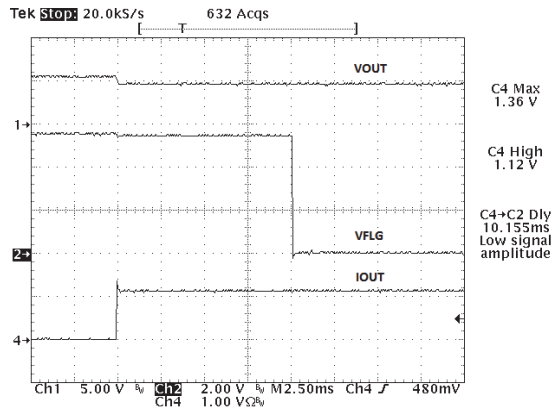

Fig. 25: Current Limit Operation (XRP2525-1):
VIN=5.5V, Rload = 3.9Ω

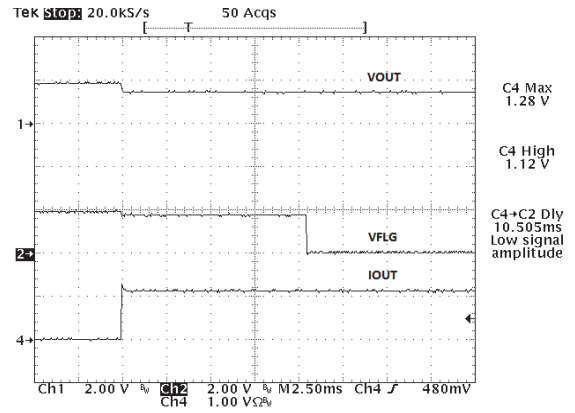
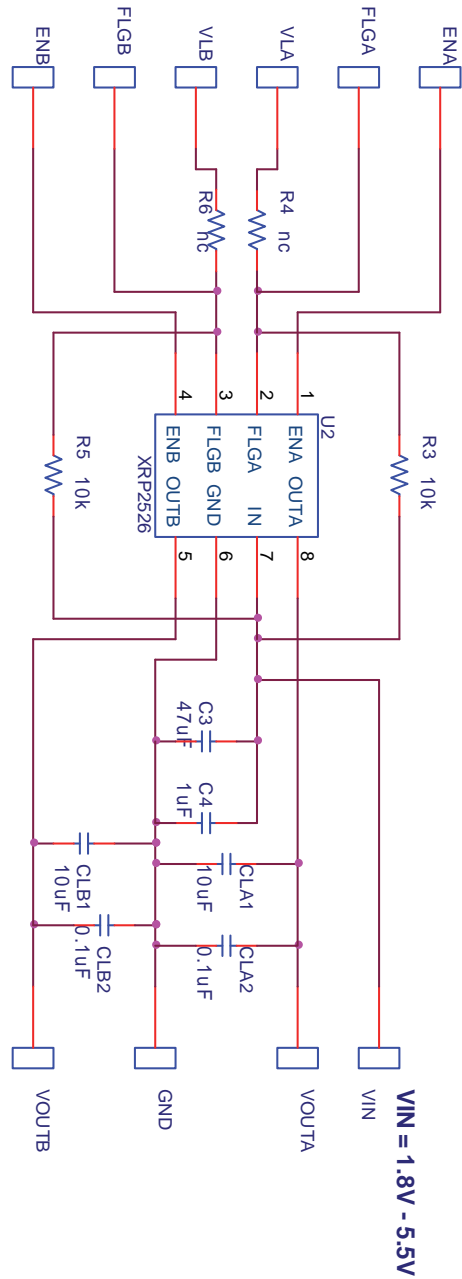
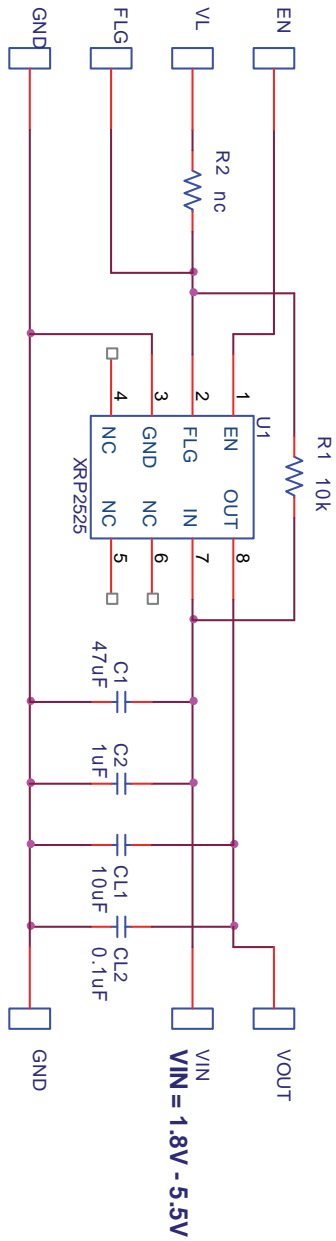

Fig. 26: Current Limit Operation (XRP2526-1):
VIN=1.8V, Rload = 1.5Ω

EVALUATION BOARD SCHEMATICS





BILL OF MATERIAL

Ref.	Qty	Manufacturer	Part Number	Size	Component
EVAL BD	1	Exar Corp.	146-6689-01		XRP2525/26 Evaluation Board
U1	1	Exar Corp.	XRP2525ID-1-F	8-pin NSOIC	XRP2525-1
U2	1	Exar Corp.	XRP2526ID-1-F	8-pin NSOIC	XRP2526-1
C1, C3	2	Murata Corp.	GRM32ER61C476KE15L	1210	Ceramic 47uF, 16V, X5R
CL1, CLA1, CLB1	3	Murata Corp.	GRM21BR61C106KE15L	0805	Ceramic 10uF, 16V, X5R
CL2, CLA2, CLB2	3	Murata Corp.	GRM188R71H104KA93D	0603	Ceramic 0.1uF, 50V, X7R
C2, C4	2	Murata Corp.	GRM188R71E105KA12D	0603	Ceramic 1uF, 25V, X7R
R1, R3, R5	6	Panasonic Corp.	ERJ-3EKF1002V	0603	Resistor 10KΩ, 1/10W, 1%
R2, R4, R6	3			0603	Not populated
Test Point VIN, GND, PGND, VOUT, VOUTA, VOUTB, EN, ENA, ENB, FLG, FLGA, FLGB, VL, VLA, VLB	19	VECTOR	K24C/M	0.042" diameter	Test Point Post

EVALUATION BOARD LAYOUT

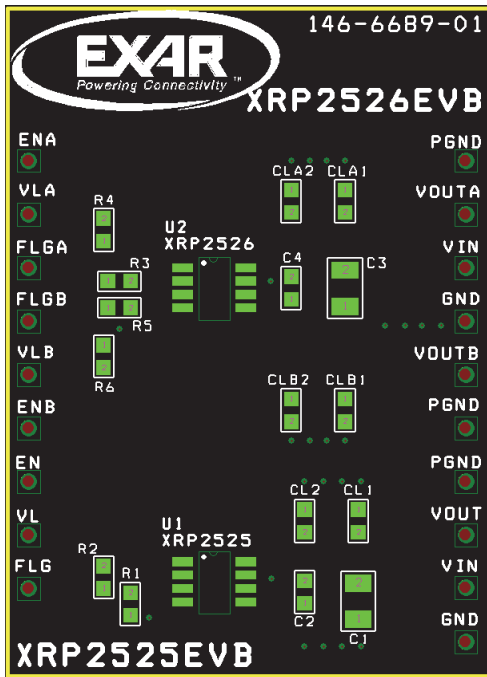

Fig. 27: Component Placement – Top Side

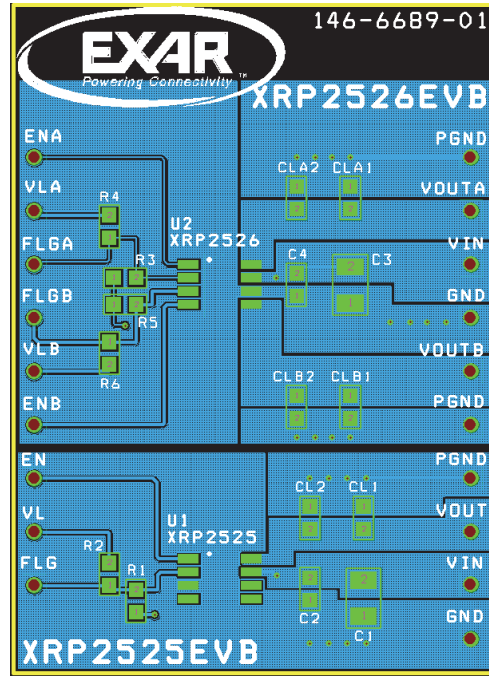

Fig. 28: Top Side Layout

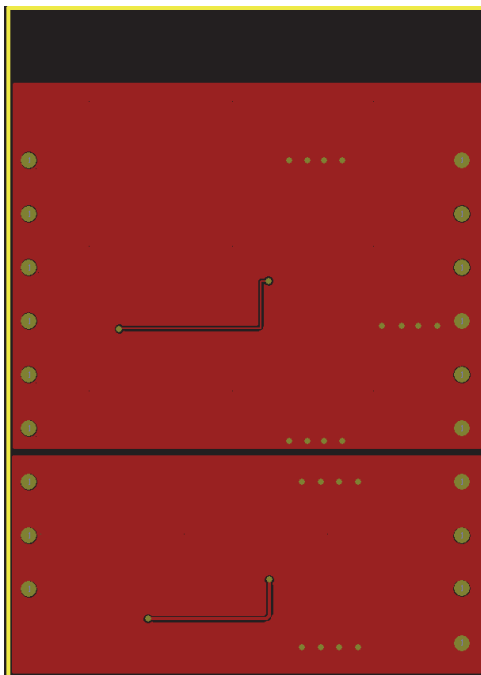

Fig. 29: Bottom Side Layout



DOCUMENT REVISION HISTORY

Revision	Date	Description
1.0.0	05/13/2011	Initial release of evaluation board manual

BOARD REVISION HISTORY

Board Revision	Date	Description
146-6689-01	05/13/2011	Initial release of evaluation board

FOR FURTHER ASSISTANCE

Email: customersupport@exar.com
Exar Technical Documentation: <http://www.exar.com/TechDoc/default.aspx?>

EXAR CORPORATION

HEADQUARTERS AND SALES OFFICES

48720 Kato Road
Fremont, CA 94538 – USA
Tel.: +1 (510) 668-7000
Fax: +1 (510) 668-7030
www.exar.com



NOTICE

EXAR Corporation reserves the right to make changes to the products contained in this publication in order to improve design, performance or reliability. EXAR Corporation assumes no responsibility for the use of any circuits described herein, conveys no license under any patent or other right, and makes no representation that the circuits are free of patent infringement. Charts and schedules contained here in are only for illustration purposes and may vary depending upon a user's specific application. While the information in this publication has been carefully checked; no responsibility, however, is assumed for inaccuracies.

EXAR Corporation does not recommend the use of any of its products in life support applications where the failure or malfunction of the product can reasonably be expected to cause failure of the life support system or to significantly affect its safety or effectiveness. Products are not authorized for use in such applications unless EXAR Corporation receives, in writing, assurances to its satisfaction that: (a) the risk of injury or damage has been minimized; (b) the user assumes all such risks; (c) potential liability of EXAR Corporation is adequately protected under the circumstances.

Reproduction, in part or whole, without the prior written consent of EXAR Corporation is prohibited.